

# East Lake Sammamish Master Plan Trail Inglewood Hill Road Parking Lot Draft Stormwater Technical Information Report

Prepared for  
King County

October 2016

**Exhibit 13**  
Prepared by  
**SSDP2016-00414**  
**Parametrix**  
**000151**

# East Lake Sammamish Master Plan Trail Inglewood Hill Road Parking Lot Draft Stormwater Technical Information Report

*Prepared for*

**King County**

Division of Capital Planning and Development  
Facilities Management Division, DES  
King County Administration Building  
500 Fourth Avenue, Room 320  
Seattle, WA 98104

*Prepared by*

**Parametrix**

719 2nd Avenue, Suite 200  
Seattle, WA 98104  
T. 206.394.3700 F. 1.855.542.6353  
[www.parametrix.com](http://www.parametrix.com)

**Exhibit 13  
SSDP2016-00414  
000152**

## CITATION

Parametrix. 2016. East Lake Sammamish Master Plan Trail  
Inglewood Hill Road Parking Lot  
Draft Stormwater Technical Information Report. Prepared by  
Parametrix, Seattle, WA. October 11, 2016.

**Exhibit 13**  
**SSDP2016-00414**  
**000153**

## CERTIFICATION

The technical material and data contained in this document were prepared under the supervision and direction of the undersigned, whose seal, as a professional engineer licensed to practice as such, is affixed below.

---

Prepared by Phoebe Johannessen, P.E.

---

Checked by Craig Buitrago, P.E.

---

Approved by Jenny Bailey

**Exhibit 13**  
**SSDP2016-00414**  
**000154**



# TABLE OF CONTENTS

<b>1.</b>	<b>PROJECT OVERVIEW .....</b>	<b>1-1</b>
1.1	Project Description .....	1-1
1.2	Existing Site Conditions .....	1-1
1.3	Project Area Soils .....	1-1
1.4	Groundwater .....	1-3
<b>2.</b>	<b>CONDITIONS AND REQUIREMENTS .....</b>	<b>2-1</b>
2.1	Flow Control BMP Requirements .....	2-1
<b>3.</b>	<b>OFFSITE ANALYSIS .....</b>	<b>3-1</b>
3.1	Study Area Definition and Maps .....	3-1
3.2	Resource Review .....	3-1
3.2.1	Water Quality Problems Requiring Special Attention .....	3-1
3.3	Field Inspection .....	3-2
<b>4.</b>	<b>FLOW CONTROL AND WATER QUALITY FACILITY ANALYSIS AND DESIGN .....</b>	<b>4-1</b>
4.1	Existing Site Hydrology .....	4-1
4.1.1	Existing (Pre-developed) Land Use .....	4-1
4.2	Developed Site Hydrology .....	4-1
4.2.1	Developed Land Use .....	4-1
4.3	Performance Standards .....	4-2
4.4	Water Quality System .....	4-2
<b>5.</b>	<b>CONVEYANCE SYSTEM ANALYSIS AND DESIGN .....</b>	<b>5-1</b>
<b>6.</b>	<b>SPECIAL REPORTS AND STUDIES .....</b>	<b>6-1</b>
<b>7.</b>	<b>OTHER PERMITS .....</b>	<b>7-1</b>
<b>8.</b>	<b>TESC DESIGN .....</b>	<b>8-1</b>
<b>9.</b>	<b>BOND QUANTITIES, FACILITY SUMMARIES, AND DECLARATION OF COVENANT .....</b>	<b>9-1</b>
<b>10.</b>	<b>OPERATION AND MAINTENANCE .....</b>	<b>10-1</b>
10.1	Stormwater Management .....	10-1
10.2	Vegetation Management .....	10-1

**Exhibit 13**  
**SSDP2016-00414**  
**000155**

## TABLE OF CONTENTS (CONTINUED)

**11. REFERENCES ..... 11-1**

### LIST OF FIGURES

1-4 Environmentally Sensitive Areas..... 1-2  
1-5 Erosion Hazards Near Sensitive Water Bodies Overlay ..... 1-3

### LIST OF TABLES

2-1 Summary of Project Area Impervious Surfaces ..... 2-1  
2-2 Summary of Core and Special Requirements ..... 2-1

### APPENDICES

A Drainage Plans, Profiles, and Detail Sheets  
B WWHM Report  
C Maintenance Requirements

DRAFT

## ACRONYMS

BMP	best management practice
BNSF	Burlington Northern Santa Fe
CARA	Critical Aquifer Recharge Area
cfs	cubic feet per second
CMP	corrugated metal pipe
DO	dissolved oxygen
Ecology	Washington State Department of Ecology
ELSP	East Lake Sammamish Parkway
ELST	East Lake Sammamish Trail
HDPE	high density polyethylene
2009 Manual	King County Surface Water Design Manual of 2009
Master Plan Trail	East Lake Sammamish Master Plan Trail
MGSFloodV4	MGSFlood Version 4
NPDES	National Pollutant Discharge Elimination System
NRCS	Natural Resources Conservation Service
O&M	operation and maintenance
PGIS	pollution-generating impervious surfaces
Q100	100-year peak flow rate
Sta.	station
TDA	threshold discharge area
TESC	temporary erosion and sediment control
TIR	technical information report
TMDL	total maximum daily load
WDFW	Washington Department of Fish and Wildlife
WWHM4	Western Washington Hydrology Model version 4
WRIA	Water Resource Inventory Area

# 1. PROJECT OVERVIEW

## 1.1 Project Description

The East Lake Sammamish Master Plan Trail (Master Plan Trail) Project begins at Gilman Boulevard in Issaquah and ends 200 feet south of Bear Creek in Redmond. The East Lake Sammamish Trail (ELST) is located on the alignment of the former Burlington Northern Santa Fe (BNSF) railroad that began operations in 1855 and ceased operations along this corridor in 1996. King County acquired the rail-banked corridor in 1998 and completed construction of an interim trail in 2006. The ELST corridor travels along the east shore of Lake Sammamish. Proposed improvements will be constructed in multiple phases, which correspond with the three jurisdictions the trail crosses—Redmond, Sammamish, and Issaquah.

The Redmond Section of the trail was constructed in 2011 and the Issaquah Section was constructed in 2013. The North Sammamish Section was constructed in 2015. The entire 4.8-mile South Sammamish Section of the ELST is separated into two construction phases: Segments A and B. Segment A is approximately 1.3 miles long from the city of Issaquah boundary at the south end to SE 33rd Street at the north terminus. Segment B is approximately 3.5 miles long from SE 33rd Street at the south end to the Inglewood Hill Road Parking Lot at the north terminus.

This technical information report (TIR) provides stormwater design documentation for the Inglewood Hill Parking Lot and a 425-foot-long segment of the trail below the parking lot. The TIR Worksheet (Figure 1-1) provides a general overview of the components of this report. A site location map is provided a Figure 1-2.

## 1.2 Existing Site Conditions

The ELST is an 8- to 12-foot-wide gravel trail located on a historical railroad prism that generally runs along the east side of Lake Sammamish. Lake Sammamish is located within one-quarter mile downstream of the trail within the project site. The site is located in the Panhandle Basin of the East Lake Sammamish Drainage Basins. Flow Control Figure 2-1 shows the drainage basins. East Lake Sammamish Parkway (ELSP) forms the eastern boundary of the project.

A gravel parking lot and sand filter vault are currently located where the proposed parking lot improvements and other amenities would occur. The gravel parking lot was constructed by the City of Sammamish in 2009. The main purpose of the project was to install a sand filter vault to provide water quality treatment for stormwater runoff for the East Lake Sammamish Parkway improvements. The sand filter vault was designed to accommodate treatment of the stormwater runoff from the County's future Inglewood Hill Road Parking Lot (Perteet 2008).

## 1.3 Project Area Soils

Natural Resources Conservation Service (NRCS) soil maps were used to show the existing soils within the project corridor. Figure 1-3 depicts the soils by type and hydrologic group. According to the NRCS map, the project site consists of Kitsap Silt Loam, hydrologic soil type C.

A geotechnical survey was completed by Icicle Creek Engineers, Inc. date February 10, 2016 for the parking lot area. Parametrix engineers used the information in the geotechnical report to design retaining walls for

Exhibit 13  
SSDP2016-00414  
000158

the parking lot. The soil borings do not agree with the NRCS soil map. Instead, the five soil borings revealed recessional outwash overlain by fill in some areas (Icicle Creek Engineers 2016).

### Sensitive Areas Geologic Hazards

City of Sammamish Environmentally Sensitive Areas Geologic Hazards map was used to identify the erosion and landslide hazard areas within the project site. Figure 1-4 depicts the geologic hazards in the project vicinity (outlined in blue). As shown below, only seismic areas are found within the project area. Erosion hazard areas occur when underlying soils types like EvD and KpD are combined with slopes steeper than 15 percent. Although the NRCS Soils map indicates Kitsap Silt Loam on the site, the geotechnical investigation found outwash soils. Therefore, the site is not considered an erosion hazard area. Additionally, because the underlying soils (recessional outwash) are not particularly sensitive to liquefaction, the site should not be considered a seismic hazard either (Icicle Creek 2016).



Figure 1-4. Environmentally Sensitive Areas

**Exhibit 13**  
**SSDP2016-00414**  
**000159**



**Figure 1-5 Erosion Hazards Near Sensitive Water Bodies Overlay**

Source: City of Sammamish Data (2013)

## 1.4 Groundwater

### Parking Lot Area

At the time of drilling, no groundwater was found in the five borings in the parking lot area. Two piezometers were installed in the parking lot area to monitor depth to groundwater. The groundwater level was measured on September 29, 2015 and January 25, 2016 and no water was observed.

### Trail Area

The geotechnical exploration for the ELST South Sammamish Segment was conducted in September and October 2013. Soil boring B-71 is approximately xx feet south of the project limit and B-72 is located within the project site at approximate station A-471+00. Both borings were drilled to a depth of 16.5 feet below ground surface on October 7, 2013. No water was encountered in B-71 and water was encountered at 13 feet in B-72. Groundwater monitoring will be conducted prior to final design of the infiltration facility.

### Critical Aquifer Recharge Area

The project site is located within the City of Sammamish Critical Aquifer Recharge Areas (CARA), Class 3 CARA. Class 3 CARAs are defined as being located outside wellhead protection areas that have high aquifer recharge potential.

**Exhibit 13**  
**SSDP2016-00414**  
**000160**

The Sammamish Municipal Code (SMC) 21A.50.280 provides development standards for projects that are located in Class 3 CARA. There is a requirement to infiltrate 75-percent of on-site water generated from the project site unless infiltration is not feasible. Runoff from the trail will be infiltrated. The trail is a non-pollution generating surface; therefore, infiltrating runoff from this area will not increase the risk of contamination to drinking water supplies.

Because the existing sand filter and outfall system were designed to handle runoff from the parking lot, infiltration was not considered for this area. It was also assumed that infiltration would not be advisable due high retaining wall and relatively steep slopes in the area of the parking lot. The geotechnical report will be amended to assess the potential for infiltration in this area.

DRAFT

## 2. CONDITIONS AND REQUIREMENTS

The City of Sammamish Surface Water Design Manual Addendum directs projects disturbing over an acre to use the 2009 King County Surface Water Design Manual (KCSWDM) guidelines, in conjunction with the City of Sammamish Addendum published in 2011 (City of Sammamish 2011). The project lies within the Panhandle Basin, which is designated as a Level 2 Flow Control area (Figure 2-1).

Based on the 2009 KCSWDM and the City of Sammamish Addendum, the project requires a full drainage review because it will result in greater than 2,000 square feet of new and replaced impervious surface. Table 2-1 provides a summary of the existing and proposed impervious surfaces within the project site. For the impervious surfaces presented in the project area summary (Table 2-1), the existing gravel trail and parking lot were assumed to be impervious; however, for Chapter 4, flow control calculations were done assuming that the existing trail is forested, in accordance with the 2009 KCSWDM requirements.

**Table 2-1. Summary of Project Area Impervious Surfaces**

	<b>Impervious Surface (acre)</b>	<b>Total Site Area (acre)</b>	<b>Percent Impervious Surface</b>
Existing	0.37	2.0	<b>18%</b>
Proposed	0.95	2.0	<b>48%</b>

This project meets the eight core requirements and five special requirements outlined in Table 1.1.2.A in the 2009 Manual. The core and special requirements were analyzed for each TDA; this section describes, generally, how this project will meet each requirement (Table 2-2). The details of the analysis, including the basis of the hydrologic and hydraulic design, are discussed in subsequent sections.

The City of Sammamish Addendum provides a list of impaired water bodies. The only water body that applies to this project is Lake Sammamish, which is a Category 5 (requiring a total maximum daily load [TMDL] plan) for dissolved oxygen and fecal coliform, and a Category 2 (water of concern) for total phosphorus. Section 1.2.2.3 Water Quality Problem Impact Mitigation of the 2009 Manual provides treatment options for projects draining to water bodies with bacteria, dissolved oxygen, and phosphorus problems.

The runoff from the parking lot will be treated in the existing sand filter vault, which was sized to accommodate runoff from the proposed parking lot. The sand filter meets the treatment requirements for the Bacterial Problem, Dissolved Oxygen Problem, and Phosphorus Problem.

### 2.1 Flow Control BMP Requirements

Section 5.2 of the KCSWDM, states that portions of projects that are subject to flow control requirements and will not be served by an infiltration facility must apply flow control best management practices (FCBMPs). Runoff from the trail will be served by an infiltration facility; however, runoff from the parking lot will be treated in the existing sand filter and conveyed directly to Lake Sammamish as previously agreed upon in the East Lake Sammamish Parkway TIR (Perteet 2008). Therefore, FCBPPs will not be employed for the parking lot runoff.



**Table 2-2. Summary of Core and Special Requirements**

<b>Core and Special Requirements per Table 1.1.1.A of the 2009 Manual</b>	<b>Proposed Stormwater Management Approach</b>
C1 Discharge Location	The discharge from the parking will be conveyed to Lake Sammamish in the City’s stormwater pipe, consistent with the discharge point for the existing gravel parking lot.
C2 Offsite Analysis	Conducted offsite analysis.
C3 Flow Control	The project is subject to conservation flow control area requirements.  This project will use the direct discharge exemption for the parking lot area and will infiltrate stormwater from the trail.
C4 Conveyance	A new conveyance system consisting of catch basins and pipes will be constructed to collect water from the new parking lot and tie into the City’s stormwater discharge pipe to Lake Sammamish.
C5 Temporary Erosion and Sediment Control (TESC)	A TESC plan is provided in the project plans.
C6 Operation and Maintenance (O&M)	Prepare O&M plan. To be added.
C7 Financial	Not applicable.
C8 Water Quality	Non-motorized trails are considered non-PGIS. Water quality treatment is not required for non-PGIS. Water quality treatment is required if a project TDA has greater than 5,000 square feet of new and replaced PGIS. Water quality treatment will be provided for runoff from the parking lot in the existing sand filter vault.
S1 Other Adopted Requirements	No area-specific requirements apply to this project.
S2 Flood Hazard Area Delineation	This special requirement is not applicable to this project because the project is not in the 100-year floodplain.
S3 Flood Protection Facilities	This special requirement is not applicable to this project because the project is not in the 100-year floodplain.
S4 Source Control	This special requirement is not applicable to this project because it does not meet the commercial development permit threshold.
S5 Oil Control	This special requirement is not applicable to this project because does not meet the high-use site threshold.

## 3. OFFSITE ANALYSIS

### 3.1 Study Area Definition and Maps

The project lies within the Washington State Department of Ecology's (Ecology) Water Resource Inventory Area (WRIA) 8, East Lake Sammamish Basin.

### 3.2 Resource Review

The existing parking lot configuration and the existing sand filter and outfall were constructed by the City of Sammamish in 2009. The City is currently upsizing and relocating the stormwater outfall from the sand filter to accommodate additional runoff from the Inglewood Hill basin above. The outfall will continue to discharge stormwater to Lake Sammamish at approximately the same location after their project is completed.

Parametrix reviewed various resources to identify the sensitive areas within the project area. Resources include the King County iMAP: Interactive Mapping Tool, which allows usage of the County's geographic information system (GIS) data, and the City of Sammamish maps that are provided on the City's website, and via GIS data transfer from the City GIS manager. Sensitive areas within the project area include seismic hazard areas, landslide hazard areas, erosion hazard areas, and Lake Sammamish, with its associated flood hazards downslope of the project. A portion of the project also is located within the Erosion Hazards near sensitive water bodies – Special district overlay.

Review of the City of Sammamish Environmentally Sensitive Areas Map indicates that project right-of-way is within the 100-year floodplain of Lake Sammamish. Using the Federal Emergency Management Agency (FEMA) Flood Insurance Rate Map (FIRM) 530330685F, effective May 16, 1995, the 100-year floodplain elevation for Lake Sammamish is 33.00 feet (NGVD 29). The vertical datum for the project is NAVD 88. To convert from NVGD 29 to NAVD 88 the datum shift adds 3.57 feet to get 36.57 feet (NAVD 88). Trail improvements occur at elevations above 45 feet (NAVD 88) and driveway improvements occur at elevations greater than 39 feet (NAVD 88). Therefore, although the 100-year floodplain boundary line is depicted within the project right-of-way, the proposed project improvements will not impact the 100-year floodplain elevation. The 100-year floodplain boundary is depicted on (to be provided). Trail elevations are located on the plan sheets located in Appendix A.

#### 3.2.1 Water Quality Problems Requiring Special Attention

The City of Sammamish Surface Water Design Manual Addendum provides a list of impaired water bodies, based on the Department of Ecology 2008 Water Quality Assessment, approved by the US. Environmental Protection Agency on January 29, 2009. The only water body that applies to this project is Lake Sammamish, which is a Category 5 (requiring a total maximum daily load [TMDL] plan) for dissolved oxygen and fecal coliform, and a Category 2 (water of concern) for total phosphorus. Section 1.2.2.3 Water Quality Problem Impact Mitigation of the 2009 KCSWDM provides treatment options for projects draining to water bodies with bacteria, dissolved oxygen, and phosphorus problems. These will be addressed under Section 4.5 below.

### 3.3 Field Inspection

The site is currently being used as interim parking for access to the trail and is temporarily serving as construction staging for the city's stormwater outfall project. The parking areas and pathways are surfaced with gravel and other areas are covered in grass or shrubs and trees.

DRAFT

## 4. FLOW CONTROL AND WATER QUALITY FACILITY ANALYSIS AND DESIGN

### 4.1 Existing Site Hydrology

#### 4.1.1 Existing (Pre-developed) Land Use

The definition of new impervious surface includes existing gravel surfaces that are upgraded to pavement (King County 2009). Target surfaces do not include existing impervious surfaces that are not disturbed by project activities.

For the purposes of this analysis, it was assumed that target surfaces requiring mitigation within Conservation Flow Control areas include the following:

- Areas within the new trail limits
- Retaining walls (concrete blocks)
- Parking lot and driveways
- Plaza area and sidewalks

The project used the hydrologic model Western Washington Hydrology Model version 4 (WWHM4) to determine flow control requirements. WWHM4 is an approved hydrologic model in accordance with Chapter 3 of the City Amendment. To comply with flow control requirements, pre-developed land uses within target surface areas were assumed to have a historical (forested) land use. Pre-developed land uses outside the target surfaces were not modeled. The native soils underlying the trail corridor are outwash soils.

### 4.2 Developed Site Hydrology

#### 4.2.1 Developed Land Use

##### Parking Lot Area

The existing gravel parking lot will be regraded, enlarged, and paved. A plaza with restroom facilities, picnic table, and covered bicycle parking will be added to the north end of the site. A paved ramp will be constructed to connect the parking lot to the East Lake Sammamish Trail. Several retaining walls will be constructed to support the parking, plaza, and ramp.

##### Trail Area

The proposed project will upgrade the existing 10-foot-wide gravel trail to a 12-foot-wide paved trail with 2- to 3-foot-wide gravel shoulders. Retaining walls are proposed in places to reduce the disturbed area. The paved trail and the gravel shoulders are new impervious surfaces. Non-target surfaces in the proposed conditions do not change from existing conditions, and were not modeled.

## 4.3 Performance Standards

A Level 2 flow control standard applies to this project according to City Ordinance 02011-304, Title 13 Surface Water Management. The Level 2 flow control performance standard requires flow control facilities to match developed discharge durations to pre-developed durations for the range of pre-developed discharge rates from 50 percent of the 2-year peak flow up to the full 50-year peak flow. Also, the facilities would match developed peak discharge rates to pre-developed peak discharges rates for the 2- and 10-year return periods. For land use, the historical site condition (forest) is assumed as the pre-developed condition.

### Flow Control System

#### **Direct Discharge Exception**

The direct discharge exception to the flow control requirement will be used for runoff from the parking lot area and the plaza. As stated in the TIR prepared for the East Lake Sammamish Parkway project, the existing sand filter and outfall systems were designed to treat and convey runoff from the project to Lake Sammamish.

#### **Infiltration Facility**

An infiltration trench will be used to infiltrate runoff from the 426 feet of trail surface and the paved ramp from the parking lot. The total area to be infiltrated is 0.27 acre. The infiltration trench will be constructed under the east shoulder of the trail. The trench will be 2 feet wide where not adjacent to walls and 3 feet wide where adjacent to the retaining wall for ease of constructability. The trench will be 2 feet deep with 6 inches of crushed clean rock above the trench to serve as surfacing for the trail shoulder.

The report from WWHM is provided in Appendix B. An infiltration rate of 10 inches per hour was used for sizing the trench. This is consistent with the long-term infiltration rates recommended by Icicle Creek Engineers for other areas with outwash soils encountered along the ELST South Sammamish Segment B (Icicle Creek Engineers, 2016a). The infiltration trench was modeled using a weighted average width of 2.2 feet corresponding to

#### **Soil Amendment**

This project will comply with the City of Sammamish's Soil Amendment Requirement for all disturbed pervious areas adjacent to the trail in accordance with Section 1.2 of the City of Sammamish Solid Waste Design Manual Addendum.

## 4.4 Water Quality System

The new trail surface will be non-PGIS and therefore no treatment is required. The ramp down from the plaza to the trail will also be non-PGIS and will not be treated. Runoff from the plaza and sidewalks adjacent to the parking lot will also be non-PGIS, but will be combined with runoff with the parking lot and so will be treated in the sand filter with the parking lot runoff. The total area draining to the sand filter vault is 0.53 acre.

The sand filter meets the treatment requirements for the Bacterial Problem, Dissolved Oxygen Problem, and Phosphorus Problem as is required for PGIS runoff draining to Lake Sammamish.

**Exhibit 13**  
**SSDP2016-00414**  
**000167**

## 5. CONVEYANCE SYSTEM ANALYSIS AND DESIGN

A conveyance system consisting of catch basins and storm drain pipes was designed to collect runoff from the parking lot and plaza area and convey it to the existing sand filter vault.

DRAFT

## 6. SPECIAL REPORTS AND STUDIES

Special reports and studies have been completed for this project including the following:

- Draft Geotechnical Engineering Report (Icicle Creek Engineers, Inc. 2016).

DRAFT

## 7. OTHER PERMITS

Other permits required for this project are listed below.

- City of Sammamish Substantial Shoreline Development Permit
- City of Sammamish Grading Permit
- National Pollutant Discharge Elimination System (NPDES) General Construction Permit
- Building permit for structural walls and restroom facility

DRAFT

**Exhibit 13  
SSDP2016-00414  
000170**



## 8. TESC DESIGN

The temporary erosion and sediment control plans are provided in the construction drawings.

DRAFT

## 9. BOND QUANTITIES, FACILITY SUMMARIES, AND DECLARATION OF COVENANT

The project does not require Bond Quantities.

DRAFT

## 10. OPERATION AND MAINTENANCE

### 10.1 Stormwater Management

The stormwater system for the Inglewood Hill Parking Lot and the adjacent section of ELST consists of storm drains, catch basins, and an infiltration trench. Excerpts from Appendix A of the 2009 Manual describe the maintenance requirements for the following project components; these excerpts are provided in Appendix C.

- Infiltration Facilities
- Catch Basins and Manholes
- Conveyance Pipes and Ditches

#### Infiltration Trenches

Infiltration trenches are designed to infiltrate runoff from the trail up to the 100-year storm event. The trenches are designed to drain within 2 days following a storm event. Monitoring wells are not necessary and will not be provided to monitor the depth of water in the trenches. Also, the top 6 to 12 inches of crushed rock will be monitored for sediment buildup. The project design requires that the trenches be wrapped with geotextile fabric, which should keep the drain rock inside the trenches clean, so that only the top crushed rock would need to be replaced.

### 10.2 Vegetation Management

King County Parks Department uses a Vegetation Management Plan prepared for the East Lake Sammamish Interim Use Trail. Chapter 5 of that plan describes maintenance activities for drainage, including dry and wet ditches, clearing of clogged culverts, and repair of ditches and culverts. The plan also specifies monitoring of ditches and culverts at least twice a year, including once in the fall before the rainy season.

King County's contact person for maintenance issues is Robert Nunnenkamp. His contact information is:

Email: [Robert.Nunnenkamp@kingcounty.gov](mailto:Robert.Nunnenkamp@kingcounty.gov)

Telephone: 206-291-7301

## 11. REFERENCES

- City of Sammamish. 2011. City of Sammamish Surface Water Design Manual Addendum. Sammamish, WA. Available at:  
<http://www.sammamish.us/departments/publicworks/StormwaterManagement.aspx?Show=Engineers>.
- Icicle Creek Engineers, Inc. 2016. Draft Report, Geotechnical Engineering Services, East Lake Sammamish Trail, Inglewood Hill Parking Lot. Sammamish, Washington. Prepared by Icicle Creek Engineers, Inc. February 10, 2016.
- Icicle Creek Engineers, Inc. 2016a. Draft Report, Geotechnical Engineering Services, South Sammamish Segment B, East Lake Sammamish Trail, Sammamish, Washington. Prepared by Icicle Creek Engineers, Inc. October, 2016.
- King County. 2009. King County Surface Water Design Manual. Prepared by King County Department of Natural Resources and Parks, Seattle, WA.
- Perteet Inc., 2008. Technical Information Report for East Lake Sammamish Parkway, Everett, WA.

DRAFT

# Appendix A

## Drainage Plans, Profiles, and Detail Sheets

**Exhibit 13**  
**SSDP2016-00414**  
**000175**

# East Lake Sammamish Master Plan Trail, Inglewood Hill Road Parking Lot Intersection of NE Inglewood Hill Rd and East Lake Sammamish Parkway NE

## King County, Washington

### Contract No. XXXX

**EXISTING ZONE CLASSIFICATION:**

COMMUNITY FACILITIES CF-F

**EXISTING SHORELINE ENVIRONMENT DESIGNATION:**

CITY OF SAMMAMISH DESIGNATION: SHORELINE RESIDENTIAL

**GENERAL PURPOSE OF THIS PROJECT:**

TO CONSTRUCT PARKING AND RESTROOM AMENITIES FOR THE EAST LAKE SAMMAMISH TRAIL.

**CONTACT INFORMATION:**

APPLICANT:  
KING COUNTY PARKS AND RECREATION DIVISION  
201 S. JACKSON, 7TH FLR  
SEATTLE, WA 98104  
(206) 477-4552  
CONTACT: GINA AULD

ENGINEER:  
PARAMETRIX  
719 2ND AVENUE  
SUITE 200  
SEATTLE, WA 98104  
(206) 394-3700  
CONTACT: PHOEBE JOHANNESSEN, P.E.

OWNER:  
KING COUNTY PARKS AND RECREATION DIVISION

SURVEYOR:  
PARAMETRIX  
719 2ND AVENUE  
SUITE 200  
SEATTLE, WA 98104  
(206) 394-3700  
CONTACT: DANIEL THIBODEAU, PLS

UTILITY:  
ONE-CALL 1 (800) 424-5555

SAMMAMISH PLATEAU WATER AND SEWER DISTRICT  
(425) 392-6256 EXT. 223  
CONTACT: KEVIN DEROUEN

COMCAST CABLE  
(425) 867-7433  
CONTACT: DAVID BURROWS

FRONTIER COMMUNICATIONS NW INC.  
HOTLINE 1 (800) 921-8101

PUGET SOUND ENERGY  
(POWER AND GAS)  
(425) 462-3727  
CONTACT: REBECCA NICHOLAS

**PROJECT & SITE INFORMATION:**

KING COUNTY PROPOSES TO CONSTRUCT A PARKING LOT AND ACCESS TO SERVE THE EAST LAKE SAMMAMISH TRAIL AND TO DEVELOP 525 FEET OF THE MULTI-USE TRAIL IN THE CITY OF SAMMAMISH, LOCATED NORTH OF INGLEWOOD HILL ROAD. A GRAVEL PARKING LOT AND INTERIM TRAIL ARE CURRENTLY IN OPERATION.

DISTURBED AREA = 57,756 SF (1.33 AC)  
EXISTING IMPERVIOUS AREA = 16,236 SF (0.37 AC)  
PROPOSED NEW IMPERVIOUS AREA = 41,440 SF (0.95 AC)  
VOLUME OF ESTIMATED FILL = 22,780 CY  
VOLUME OF ESTIMATED EXCAVATION = 200 CY

**PROPERTY INFORMATION:**

PARCEL NUMBERS:  
357530-0260-08 (29,285 SQ. FT.)  
357530-0340-02 (9,671 SQ. FT.)  
357530-0365-02 (1,920 SQ. FT.)  
357530-0370-05 (1,669 SQ. FT.)  
357530-0460-06 (2,304 SQ. FT.)  
292506-9007 (484,668 SQ. FT.)

**WRITTEN DESCRIPTION OF THE PROJECT:**

A 30-SPACE PARKING LOT WILL BE CONSTRUCTED TO SERVE THE EAST LAKE SAMMAMISH TRAIL. IN ADDITION 525 FEET OF THE EXISTING GRAVEL TRAIL WILL BE WIDENED TO 12 FEET PAVED SURFACE WITH 2-FOOT GRAVEL SHOULDERS ON BOTH SIDES.

THE PROPOSED IMPROVEMENTS INCLUDE RETAINING WALLS, RESTROOM FACILITIES, PAVING, DRAINAGE IMPROVEMENTS, FENCE, AND SIGNAGE.

**PARCEL No. 292506-9007 (CONTINUED)**

MEASURED RADIALLY FROM SAID MAIN TRACK CENTERLINE LESS PORTIONS OF SAID LOTS 28 & 29 DEEDED TO J & E HAYDEN UNDER REC NO 9212311137 LESS PORTIONS LOTS 24 & 25 LYING EASTERLY OF LINE DRAWN CONCENTRIC WITH & 25 FEET EASTERLY AS MEASURED RADIALLY FROM SAID MAIN TRACK CENTERLINE; & PORTIONS LOTS 0 THRU 7 & LOTS 11 THRU 16 BLOCK 1 OF SAID PLAT LYING EASTERLY OF A LINE DRAWN PARALLEL & CONCENTRIC WITH & 50 FEET WESTERLY AS MEASURED AT A RIGHT ANGLE & RADIALLY FROM SAID MAIN TRACK CENTERLINE; & PORTION IF ANY SAID RAILWAY CO'S BRANCH LINE RIGHT OF WAY LYING WESTERLY OF LOTS 1 THRU 68, BLOCK 9, LOTS 19 THRU 24 BLOCK 6, LOTS 1 THRU 41 BLOCK 14; & LYING EASTERLY OF LOTS 1 THRU 22, BLOCK 4, LOTS 1 THRU 22, BLOCK 5, LOTS 1 THRU 22, BLOCK 3, LOTS 1 THRU 22, BLOCK 2 & LOTS 0 THRU 20, BLOCK 1 OF SAID PLAT.

SSDP XXXX-XXXX  
SHOR-XX-XXXX  
GRDEXX-XXXX

CITY OF SAMMAMISH APPROVAL	
City Engineer	Date
Community Development	Date

Exhibit 13  
NOT FOR CONSTRUCTION  
SSDP2016-00414  
000176

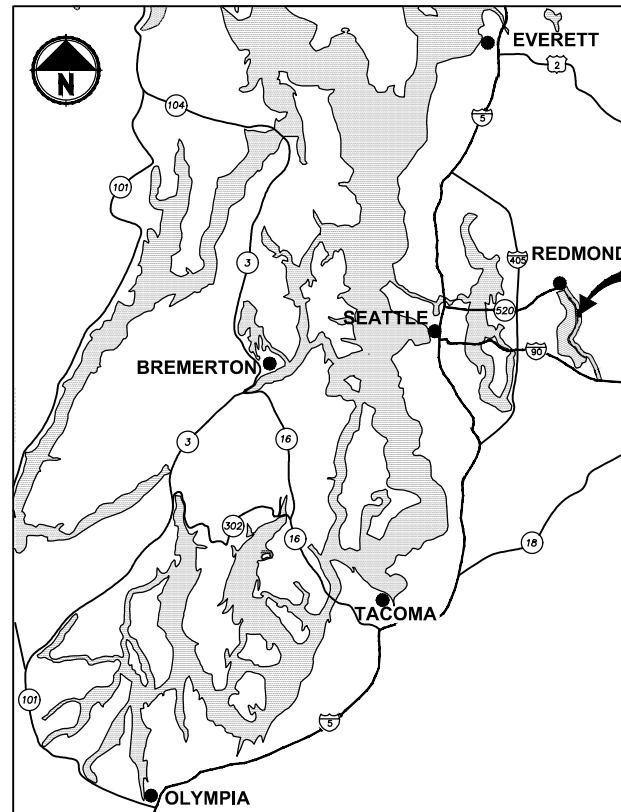

**LOCATION MAP**  
NOT TO SCALE

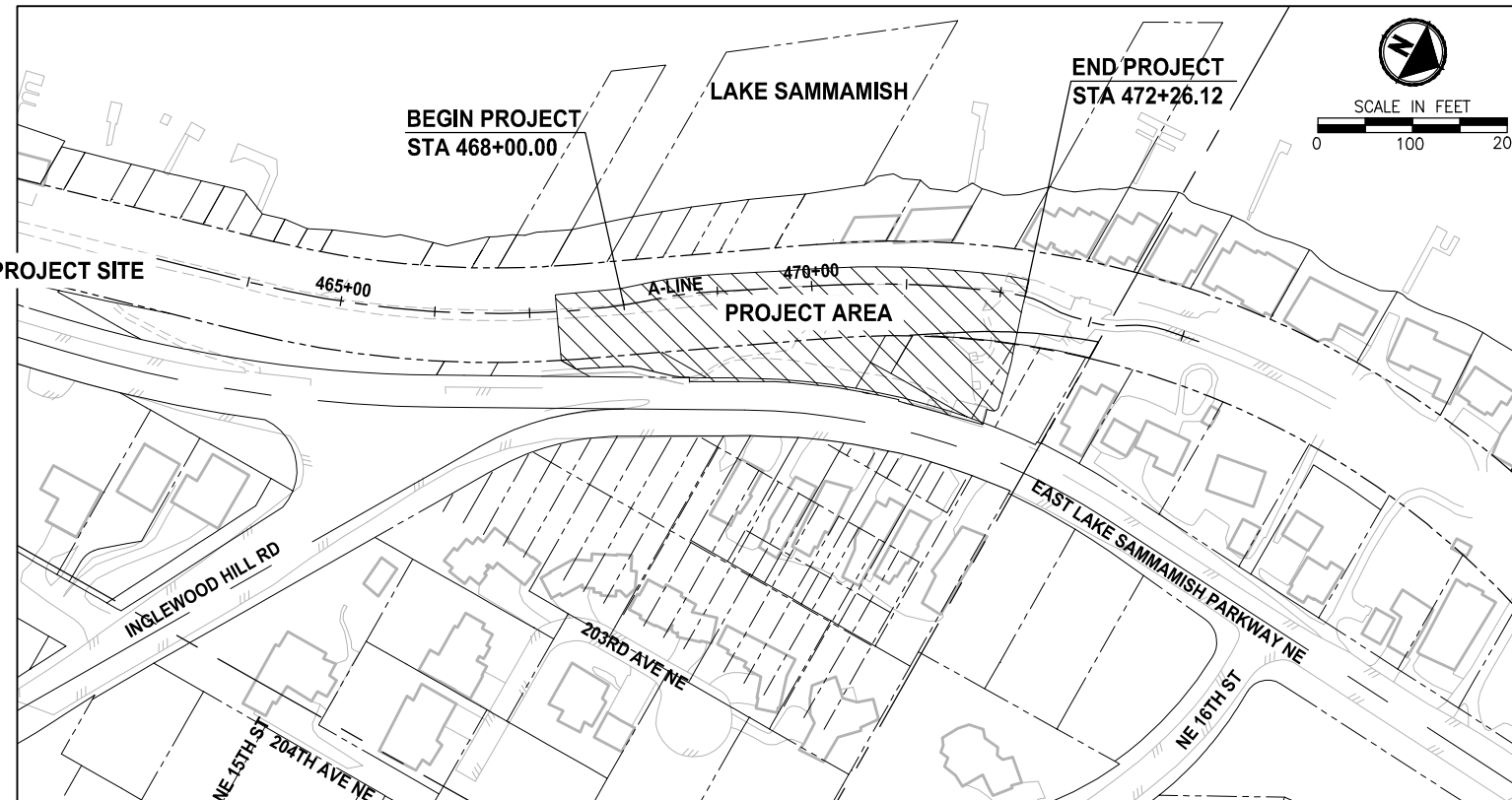

**VICINITY MAP**

**LEGAL DESCRIPTIONS:**

PARCEL No. 357530-0260-08  
PER STEWART TITLE GUARANTY COMPANY,  
GUARANTEE No. G-6329-000007871, JANUARY 8, 2016

THOSE PORTIONS OF LOTS 1 THROUGH 10, 18 THROUGH 21 AND 23 THROUGH 27, BLOCK 6, INGLEWOOD, ACCORDING TO THE PLAT THEREOF RECORDED IN VOLUME 3 OF PLATS, PAGE 169, RECORDS OF KING COUNTY, WASHINGTON, LYING WESTERLY OF THE WESTERLY MARGIN OF EAST LAKE SAMMAMISH PARKWAY N. E. (ISSAQUAH-REDMOND ROAD REVISION NO. 2); EXCEPT THAT PORTION LYING WESTERLY OF THE EASTERLY MARGIN OF THE NORTHERN PACIFIC RAILROAD RIGHT OF WAY AS CONVEYED BY DEED RECORDED UNDER RECORDING NUMBER 3051111; AND EXCEPT THOSE PORTIONS CONVEYED TO KING COUNTY FOR ROAD PURPOSES BY DEEDS RECORDED UNDER RECORDING NUMBERS 625790, 983353, 983354 AND 983355; AND EXCEPT THAT PORTION CONDEEMED FOR ROAD PURPOSES IN KING COUNTY SUPERIOR COURT CAUSE NO. 106364; AND EXCEPT THOSE PORTIONS RESERVED FOR ROAD BY KING COUNTY IN DEEDS RECORDED UNDER RECORDING NUMBERS 860989 AND 2957937; AND TOGETHER WITH THOSE PORTIONS OF VACATED DEPOT STREET ADJOINING, VACATED BY KING COUNTY SUPERIOR COURT CAUSE NUMBER 94-2-14451-1, AS WOULD ATTACH BY OPERATION OF LAW.

**LEGAL DESCRIPTION CONTINUED:**

PARCEL No. 357530-0340-02  
PER STEWART TITLE GUARANTY COMPANY,  
GUARANTEE No. G-6329-000007868, JANUARY 8, 2016

THAT PORTION OF LOT 17, BLOCK 6, INGLEWOOD, ACCORDING TO THE PLAT THEREOF RECORDED IN VOLUME 3 OF PLATS, PAGE 169, RECORDS OF KING COUNTY, WASHINGTON, LYING WESTERLY OF THE WESTERLY MARGIN OF EAST LAKE SAMMAMISH PARKWAY N. E. (ISSAQUAH-REDMOND ROAD REVISION NO. 2); EXCEPT THAT PORTION RESERVED FOR ROAD BY KING COUNTY IN DEED RECORDED UNDER RECORDING NUMBER 2957937; AND TOGETHER WITH THOSE PORTIONS OF VACATED ASH STREET (N. E. 16TH STREET) AND VACATED DEPOT STREET ADJOINING, VACATED BY KING COUNTY SUPERIOR COURT CAUSE NUMBER 94-2-14451-1, AS WOULD ATTACH BY OPERATION OF LAW.

PARCEL No. 357530-0365-02  
PER STEWART TITLE GUARANTY COMPANY,  
GUARANTEE No. G-6329-000007869, JANUARY 8, 2016

THAT PORTION OF LOT 22, BLOCK 6, INGLEWOOD, ACCORDING TO THE PLAT THEREOF RECORDED IN VOLUME 3 OF PLATS, PAGE 169, RECORDS OF KING COUNTY, WASHINGTON, LYING EASTERLY OF THE EASTERLY MARGIN OF THE NORTHERN PACIFIC RAILROAD COMPANY RIGHT OF WAY, AS CONVEYED BY DEED RECORDED UNDER RECORDING NUMBER 3051111.

**LEGAL DESCRIPTION CONTINUED:**

PARCEL No. 357530-0370-05  
PER STEWART TITLE GUARANTY COMPANY,  
GUARANTEE No. G-6329-000007867, JANUARY 8, 2016

THAT PORTION OF LOTS 11 THROUGH 16, BLOCK 6, INGLEWOOD, ACCORDING TO THE PLAT THEREOF RECORDED IN VOLUME 3 OF PLATS, PAGE 169, RECORDS OF KING COUNTY, WASHINGTON, LYING WESTERLY OF THE WESTERLY MARGIN OF EAST LAKE SAMMAMISH PARKWAY N. E. (ISSAQUAH-REDMOND ROAD REVISION NO. 2); EXCEPT THOSE PORTIONS CONVEYED TO KING COUNTY FOR ROAD PURPOSES BY DEEDS RECORDED UNDER RECORDING NUMBERS 983354 AND 983356; AND EXCEPT THAT PORTION RESERVED FOR ROAD BY KING COUNTY IN DEED RECORDED UNDER RECORDING NUMBER 769006; AND TOGETHER WITH THAT PORTION, IF ANY, OF VACATED ASH STREET (N. E. 16TH STREET) ADJOINING, VACATED BY KING COUNTY SUPERIOR COURT CAUSE NUMBER 94-2-14451-1, AS WOULD ATTACH BY OPERATION OF LAW.

**LEGAL DESCRIPTION CONTINUED:**

PARCEL No. 357530-0460-06  
PER STEWART TITLE GUARANTY COMPANY,  
GUARANTEE No. G-6329-000007870, JANUARY 8, 2016

PARCEL 1:  
THAT PORTION OF LOTS 36 THROUGH 40, BLOCK 7, INGLEWOOD, ACCORDING TO THE PLAT THEREOF RECORDED IN VOLUME 3 OF PLATS, PAGE 169, RECORDS OF KING COUNTY, WASHINGTON, LYING WESTERLY OF THE WESTERLY MARGIN OF EAST LAKE SAMMAMISH PARKWAY N. E. (ISSAQUAH-REDMOND ROAD REVISION NO. 2); EXCEPT THAT PORTION LYING WESTERLY OF THE EASTERLY MARGIN OF THE NORTHERN PACIFIC RAILROAD COMPANY RIGHT OF WAY, AS CONVEYED BY DEED RECORDED UNDER RECORDING NUMBER 3051111.

PARCEL 2:  
ALL THAT PORTION OF VACATED ILLINOIS AVENUE (202ND AVENUE N. E.), AS SHOWN ON AND DEDICATED TO THE PUBLIC IN THE PLAT OF INGLEWOOD, ACCORDING TO THE PLAT THEREOF RECORDED IN VOLUME 3 OF PLATS, PAGE 169, RECORDS OF KING COUNTY, WASHINGTON, LYING SOUTHWESTERLY OF A LINE LOCATED 30 FEET (MEASURED PERPENDICULAR TO) SOUTHWESTERLY OF AND PARALLEL TO THE CENTERLINE OF EAST LAKE SAMMAMISH PARKWAY N. E., AS VACATED BY KING COUNTY SUPERIOR COURT CAUSE NUMBER 91-2-20802-6.

**LEGAL DESCRIPTION CONTINUED:**

PARCEL No. 292506-9007

THAT PORTION OF THE BURLINGTON NORTHERN AND SANTA FE RAILWAY COMPANY'S (FORMERLY NORTHERNPACIFIC RAILWAY COMPANY) SNOQUALMIE BRANCH LINE RIGHT-OF-WAY 100 FEET IN WIDTH OVER AND ACROSS GOVERNMENT LOTS 1 & 2 LESS PORTION OF SAID GOVERNMENT LOT 2 AS DEEDED TO D.P. & E.M. STAHL UNDER REC NO 9409280762; TOGETHER WITH LOTS 1 THRU 68, BLOCK 9, PLAT OF TOWN OF INGLEWOOD LYING WESTERLY OF LINE DRAWN PARALLEL WITH & 50 FEET EASTERLY AS MEASURED AT A RIGHT ANGLE FROM MAIN TRACK CENTERLINE OF SAID BRANCH LINE RIGHT OF WAY & PORTION OF LOTS 19 THRU 24 IN BLOCK 6 OF SAID PLAT LYING WESTERLY OF LINE DRAWN CONCENTRIC WITH & 50 FEET EASTERLY AS MEASURED RADIALLY FROM SAID MAIN TRACK CENTERLINE & PORTIONS OF LOTS 1 THRU 22, BLOCK 4, LOTS 1 THRU 22, BLOCK 5 & LOTS 11 THRU 22, BLOCK 3 OF SAID PLAT LYING EASTERLY OF A LINE DRAWN PARALLEL & CONCENTRIC WITH & 50 FEET WESTERLY AS MEASURED AT A RIGHT ANGLE & RADIALLY FROM SAID MAIN TRACK CENTERLINE; & PORTIONS OF LOTS 1, 2 & 8, BLOCK 3 OF SAID PLAT LYING EASTERLY OF A LINE DRAWN PARALLEL & CONCENTRIC WITH & 50 FEET WESTERLY AS MEASURED AT A RIGHT ANGLE & RADIALLY FROM SAID MAIN TRACK CENTERLINE; & PORTIONS OF LOTS 9, 10, 12, 13 & 16 THRU 22, BLOCK 2, OF SAID PLAT LYING EASTERLY OF A LINE DRAWN CONCENTRIC & PARALLEL WITH & 50 FEET WESTERLY AS MEASURED AT A RIGHT ANGLE & RADIALLY FROM SAID MAIN TRACK CENTERLINE; & LOTS 1 THRU 41, BLOCK 14 OF SAID PLAT LESS PORTIONS OF SAID LOTS 26 THRU 41 LYING EASTERLY OF LINE DRAWN PARALLEL & CONCENTRIC WITH & 50 FEET EASTERLY AS MEASURED AT A RIGHT ANGLE & RADIALLY FROM SAID MAIN TRACK CENTERLINE LESS PORTIONS OF SAID LOTS 9 THRU 11, LYING WESTERLY OF LINE DRAWN CONCENTRIC WITH & 25 FEET WESTERLY AS MEASURED RADIALLY FROM SAID MAIN TRACK CENTERLINE LESS PORTIONS SAID OF LOTS 18 THRU 27 LYING WESTERLY OF LINE DRAWN CONCENTRIC WITH & 25 FEET WESTERLY AS

REVISIONS	DATE	BY	DESIGNED
			J. JUN
			B. PURGANN
			P. JOHANNESSEN
			Y. HO

ONE INCH AT FULL SCALE, IF NOT, SCALE ACCORDINGLY  
FILE NAME: BL1521075P21T03G-01  
JOB No.: 554-1521-075 P21T03  
DATE: OCTOBER 2016



**Parametrix**  
ENGINEERING · PLANNING · ENVIRONMENTAL SCIENCES  
719 2ND AVENUE, SUITE 200 | SEATTLE, WA 98104  
P 206.394.3700  
WWW.PARAMETRIX.COM

PROJECT NAME  
**EAST LAKE SAMMAMISH MASTER PLAN TRAIL**  
**INGLEWOOD HILL ROAD PARKING LOT**  
SAMMAMISH, WA

**COVER AND VICINITY MAP**

SHEET NO.  
1 OF 27  
**G1**

PLOTTED BY: purgann DATE: Wednesday, October 12, 2016 7:46:38 PM  
 PATH: U:\PSO\Projects\Clients\1521-1521-075-ELST\983353\CADD\Phase 2\103.Dwg  
 LAYOUT: G1

**ABBREVIATIONS:**

ACP	ASPHALT CONCRETE PAVEMENT	N	NORTH, NORTHING
BOC	BACK OF CURB	N.I.C.	NOT IN CONTRACT
BOW	BOTTOM OF WALL	NST	NOT STEEPER THAN
BVCE	BEGIN VERTICAL CURVE ELEVATION	PC	POINT OF CURVE
BVCS	BEGIN VERTICAL CURVE STATION	PT	POINT OF TANGENT
CB	CATCH BASIN	P/L	PROPERTY LINE
C&G	CURB AND GUTTER	PUD	PUBLIC UTILITY DISTRICT
C/L	CENTERLINE	PVI	POINT OF VERTICAL INTERSECTION
CONC	CONCRETE	REINF	REINFORCED
CONST	CONSTRUCTION	ROW or R/W	RIGHT-OF-WAY
CMP	CORRUGATED METAL PIPE	RR	RAIL ROAD
CP	CONCRETE PIPE	SD	STORM DRAIN
CSTC	CRUSHED SURFACING TOP COURSE	SDMH	STORMWATER MANHOLE
DIA	DIAMETER	SIM	SIMILAR
DI, DIP	DUCTILE IRON PIPE	SS	SANITARY SEWER
E	EAST, EASTING	ST	STEEL
EOA	EDGE OF ASPHALT	STA	STATION
EVCE	END VERTICAL CURB ELEVATION	TEL	TELEPHONE
EVCS	END VERTICAL CURB STATION	TESC	TEMPORARY EROSION AND SEDIMENT CONTROL
EOG	EDGE OF GRAVEL	TOW	TOP OF WALL
EOP	EDGE OF PAVEMENT	TYP	TYPICAL
EX, EXIST	EXISTING	W	WATER
FOC	FACE OF CURB	WS	WATER SERVICE
FL	FLANGE, FLOWLINE	WSDOT	WASHINGTON STATE DEPARTMENT OF TRANSPORTATION
G	GAS	WWM	WELDED WIRE MESH
GB	GRADE BREAK		
HMA	HOT MIX ASPHALT		
IE	INVERT ELEVATION		
LF	LINEAR FEET		
LP	LOW POINT		
LT	LEFT		
ME	MATCH EXISTING		
MIN	MINIMUM		
MON	MONUMENT		

INDEX TO DRAWINGS		
DWG NO.	SHT NO.	SHEET TITLE
1	G1	COVER SHEET
2	G2	ABBREVIATIONS AND SHEET LIST
3	G3	LEGEND
4	G4	SURVEY CONTROL PLAN
5	SP1	SITE PREPARATION AND TESC PLAN
6	SP2	SITE PREPARATION AND TESC PLAN
7	TD1	TESC DETAILS
8	CS1	TYPICAL CROSS SECTIONS
9	CS2	TYPICAL CROSS SECTIONS
10	AL1	PARKING LOT PLAN
11	AL2	PARKING LOT PLAN
12	AL3	PARKING LOT PROFILE
13	AL4	PARKING LOT PROFILE
14	SD1	STORM DRAIN PROFILES AND SECTIONS
15	WP1	WALL PROFILES
16	WP2	WALL PROFILES
17	WP3	WALL PROFILES
18	WD1	STRUCTURAL EARTH WALL DETAILS
19	WD2	STRUCTURAL EARTH WALL DETAILS
20	RD1	RESTROOM FACILITY DETAIL (NOT INCLUDED IN THIS SUBMITTAL)
21	UP1	UTILITY AND ELECTRICAL PLAN
22	UD1	UTILITY AND ELECTRICAL DETAILS
23	PS1	PAVEMENT MARKING AND SIGNING PLAN
24	PS2	PAVEMENT MARKING AND SIGNING PLAN
25	LD1	PLANTING SCHEDULE AND DETAILS
26	GN1	STANDARD PLAN NOTES
27	MD1	MISCELLANEOUS DETAILS

**DETAIL AND SECTION DESIGNATION**

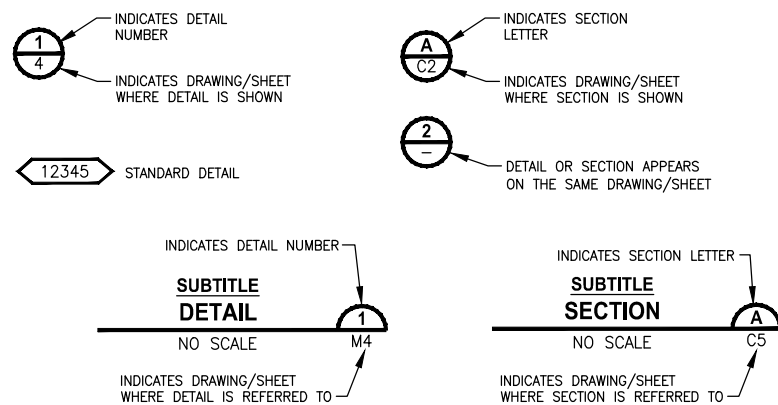

CITY OF SAMMAMISH APPROVAL	
City Engineer	Date
Community Development	Date

**Exhibit 13**  
 NOT FOR CONSTRUCTION  
**SSDP2016-00414**  
**000177**

LAYOUT: G2 PATH: U:\PSO\Projects\Clients\1521-1521-075-ELST\995\cs\CADD\Phase 2\103\Draw\ PLOTTED BY: purgabut DATE: Tuesday, October 11, 2016 7:46:32 PM

REVISIONS	DATE	BY	DESIGNED
			J. JUN
			B. PURGANAN
			P. JOHANNESSEN
			Y. HO

**ONE INCH AT FULL SCALE. IF NOT, SCALE ACCORDINGLY**

FILE NAME: BL1521075P21T03G-02  
 JOB No: 54-1521-075 P21T03  
 DATE: OCTOBER 2016

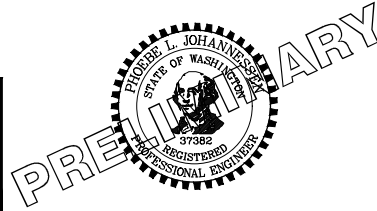

**Parametrix**  
 ENGINEERING · PLANNING · ENVIRONMENTAL SCIENCES

719 2ND AVENUE, SUITE 200 | SEATTLE, WA 98104  
 P 206.394.3700  
 WWW.PARAMETRIX.COM

PROJECT NAME  
**EAST LAKE SAMMAMISH  
 MASTER PLAN TRAIL  
 INGLEWOOD HILL ROAD PARKING LOT**  
 SAMMAMISH, WA

**ABBREVIATIONS AND SHEET LIST**

SHEET NO.  
 2 OF 27  
**G2**



SEC'S 8, 17 TWP. 24 N., RGE. 06 E, W.M.

**LEGEND**

DESCRIPTION	PROPOSED	EXISTING
RIGHT OF WAY	---	--- R/W ---
PROPERTY LINE	---	--- P/L ---
FOUND MONUMENTS		⊕ ⊗
REBAR & CAP		○
HUB & TACK		□
PK NAIL		×
FOUND MAG NAIL		+
SET MAG NAIL		+
PROPERTY CORNER		●
STREAM BUFFER	---	---
STREAM	→→→	→→→
EDGE OF WATER	---	---
WETLAND FLAG		↑
WETLAND BUFFER	---	---
ORDINARY HIGH WATER MARK	---	---
FLOODWAY BOUNDARY	---	---
DITCH	→→→	→→→
JURISDICTIONAL DITCH CENTERLINE & EDGES	→→→	→→→
UNDERDRAIN PIPE	—UD→ UD→	
TEMPORARY DRAIN PIPE	—D— D— D—	
STORM DRAIN		—SD—
CULVERT/STORM DRAIN PIPE	▬	▬
QUARRY SPALL	⊗	
INFILTRATION TRENCH	▬	
CATCH BASIN, TYPE 1	■	■
CATCH BASIN, TYPE 2	■	■
INLET PROTECTION	⊗	
SANITARY SEWER LINE	—SS—	—SS—
SANITARY SEWER MANHOLE	⊙	⊙
SANITARY SEWER VAULT	⊙	⊙
CLEANOUT	●	⊙
CONTOURS MAJOR	—10—	—10—
CONTOURS MINOR	—2—	—2—
HIGH VISIBILITY SILT FENCE	—X— X— X—	
HIGH VISIBILITY FENCE	—X— X— X—	
INTERCEPTOR SWALE	—IS—	
CLEARING AND GRUBBING LIMITS	—CLR— CLR— CLR— CLR—	
CLEARING LIMITS	—CLR— CLR— CLR— CLR—	
FILL LINE	---F--- F--- F--- F---	
CUT LINE	---C--- C--- C--- C---	
SAWCUT	▨▨▨▨▨▨▨▨▨▨	
ASPHALT EDGE	▬▬▬▬▬▬▬▬▬▬	▬▬▬▬▬▬▬▬▬▬
CONCRETE LINE	▬▬▬▬▬▬▬▬▬▬	▬▬▬▬▬▬▬▬▬▬
CURB AND GUTTER	▬▬▬▬▬▬▬▬▬▬	▬▬▬▬▬▬▬▬▬▬
EDGE OF PATCH	▬▬▬▬▬▬▬▬▬▬	▬▬▬▬▬▬▬▬▬▬

**LEGEND**

DESCRIPTION	PROPOSED	EXISTING
EDGE OF GRAVEL	---	---
BARBWIRE FENCE	—X— X— X—	—X— X— X—
SPLIT RAIL FENCE	—//— //— //—	—//— //— //—
BOARD FENCE	—□— □— □—	—□— □— □—
CHAIN LINK FENCE	—○— ○— ○—	—○— ○— ○—
TEMPORARY SAFETY FENCE	—/— /— /—	
HOG WIRE FENCE	—○— ○— ○— ○—	—○— ○— ○— ○—
WOOD GUARDRAIL	—□— □— □— □— □—	—□— □— □— □— □—
METAL HANDRAIL	—·— ·— ·— ·— ·—	
GUY ANCHOR		→
POWER POLE WITH LIGHT		⊙
FLOOD LIGHT		⊙
UTILITY POLE		⊙
PP W/ UG DROP		⊙
PP W/ UG DROP & XMFR		⊙
OVERHEAD POWER		—OP—
POWER		—P—
POWER VAULT		▭
POWER TRANSFORMER		▭
POWER MANHOLE		⊙
POWER HANDHOLE		⊙
POWER CABINET		▭ PWR CAB
POWER RISER		▭ PR
POWER METER		⊙
SOLID LID J-BOX		▭
LUMINAIRE		⊙
TELEPHONE VAULT		▭ T
TELEPHONE RISER		▭ TR
TELEPHONE MANHOLE		⊙ T
TELEPHONE		—T—
TV RISER		▭
TV		—TV—
GAS VALVE		⊙
GAS METER		⊙
GAS		—G—
WATER LINE		—W—
FIRE HYDRANT		⊙
WATER METER		⊙
WATER VALVE		⊙
AREA DRAIN		⊙
ROOF DRAIN		⊙
WATER BLOW OFF VALVE		⊙
WATER POST INDICATOR		⊙
SPRINKLER HEAD ROT=90		⊙

**LEGEND**

DESCRIPTION	PROPOSED	EXISTING
IRRIGATION CONTROL VALVE		⊙
FLOW DIRECTION	→	→
TRAFFIC SIGNAL POLE W/ LAMP		⊙
TRAFFIC SIGNAL POLE		⊙
TRAFFIC CONTROL LOOP (SQ)		⊙
TRAFFIC CONTROL CABINET		▭
PEDESTRIAN POLE		⊙
MONITORING WELL		⊙
SURFACE POST		⊙
SIGN	▭	▭
SKIP LANE LINE	---	---
SOLID LANE LINE	---	---
FOG LINE	---	---
LTO ARROW		→
STO ARROW		←
RTO ARROW		↪
MAILBOX	▭	▭
DECIDUOUS TREE		⊙
CONIFEROUS TREE		⊙
WETLAND SYMBOL		⊙
WETLAND BOUNDARY		▬
VEGETATION		▬
STRUCTURAL EARTH WALL	▬	▬
RIP RAP	▬	▬
ROCKERY	▬	▬
HANDICAPPED SYMBOL		⊙
WHEELCHAIR RAMP		▬
BUILDING LINE		▬
CONCRETE STAIR LINE		▬
WOOD STAIRWAY		▬
REMOVE ASPHALT	▬	
PATTERNED CONCRETE INTERSECTION	▬	
RAMP DETECTABLE WARNING	▬	
RESTORATION PLANTING AREA	▬	
SANDBAG DAM	▬	
CHECK DAM	▬	
WATTLE CHECK DAM	▬	
FORMER RAILROAD CENTERLINE	220 + RR C/L	
CONSTRUCTION CENTERLINE	220+00 + A-LINE	

LAYOUT: G3  
 PATH: U:\PSO\Projects\Clients\1521-1521-075-ELST\995\CAADD\Phase 2\103\Draw\...  
 PLOTTED BY: purgubut DATE: Tuesday, October 11, 2016 7:47:07 PM

REVISIONS	DATE	BY	DESIGNED
			J. JUN
			B. PURGANAN
			P. JOHANNESSEN
			Y. HO

**ONE INCH AT FULL SCALE, IF NOT, SCALE ACCORDINGLY**  
 FILE NAME: BL1521075P21T03G-03  
 JOB No.: 554-1521-075 P21T03  
 DATE: OCTOBER 2016



**Parametrix**  
 ENGINEERING · PLANNING · ENVIRONMENTAL SCIENCES  
 719 2ND AVENUE, SUITE 200 | SEATTLE, WA 98104  
 P 206.394.3700  
 WWW.PARAMETRIX.COM

PROJECT NAME  
**EAST LAKE SAMMAMISH MASTER PLAN TRAIL INGLEWOOD HILL ROAD PARKING LOT**  
 SAMMAMISH, WA

**LEGEND**

CITY OF SAMMAMISH APPROVAL	
City Engineer	Date
Community Development	Date

Exhibit 13  
 NOT FOR CONSTRUCTION  
 S5DP2016-00414  
 000178

SHEET NO.  
 3 OF 27  
**G3**



**SURVEY NOTES:**

- HORIZONTAL DATUM: NAD83 (CORS).
- RTK CORRECTIONS OBTAINED FROM NGS CORS ID POINT "SEAT" ON OCTOBER 3, 2007.
- VERTICAL DATUM: NAVD88.
- WSDOT SITE BENCHMARKS HELD FOR THIS SURVEY ARE NOS. 2355, 6762, 6294, AND 617.
- METHODOLOGY: FIELD MEASUREMENTS FOR THIS SURVEY WERE PERFORMED USING TRIMBLE 5800 RTK WITH CELL PHONE AND LEICA TCRA 1103 FULL ROBOTIC 3 SECOND TOTAL STATION IN CONFORMANCE WITH ACCEPTED SURVEY STANDARDS AS SPECIFIED BY WAC 332-130 FOR LINEAR AND ANGULAR CLOSURE.
- THE RIGHT-OF-WAY DIMENSIONS SHOWN WERE PROVIDED BY KING COUNTY SURVEY AND DO NOT REPRESENT A BOUNDARY SURVEY PERFORMED BY PARAMETRIX.

POINT TABLE				
POINT #	NORTHING	EASTING	ELEVATION	RAW DESCRIPTION
1029	229921.05	1335206.44	47.06	REBAR & CAP
1030	229669.58	1335331.02	46.27	REBAR & CAP
1031	229395.84	1335521.28	46.14	REBAR & CAP
1032	229137.35	1335620.66	46.49	REBAR & CAP

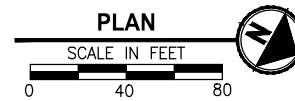
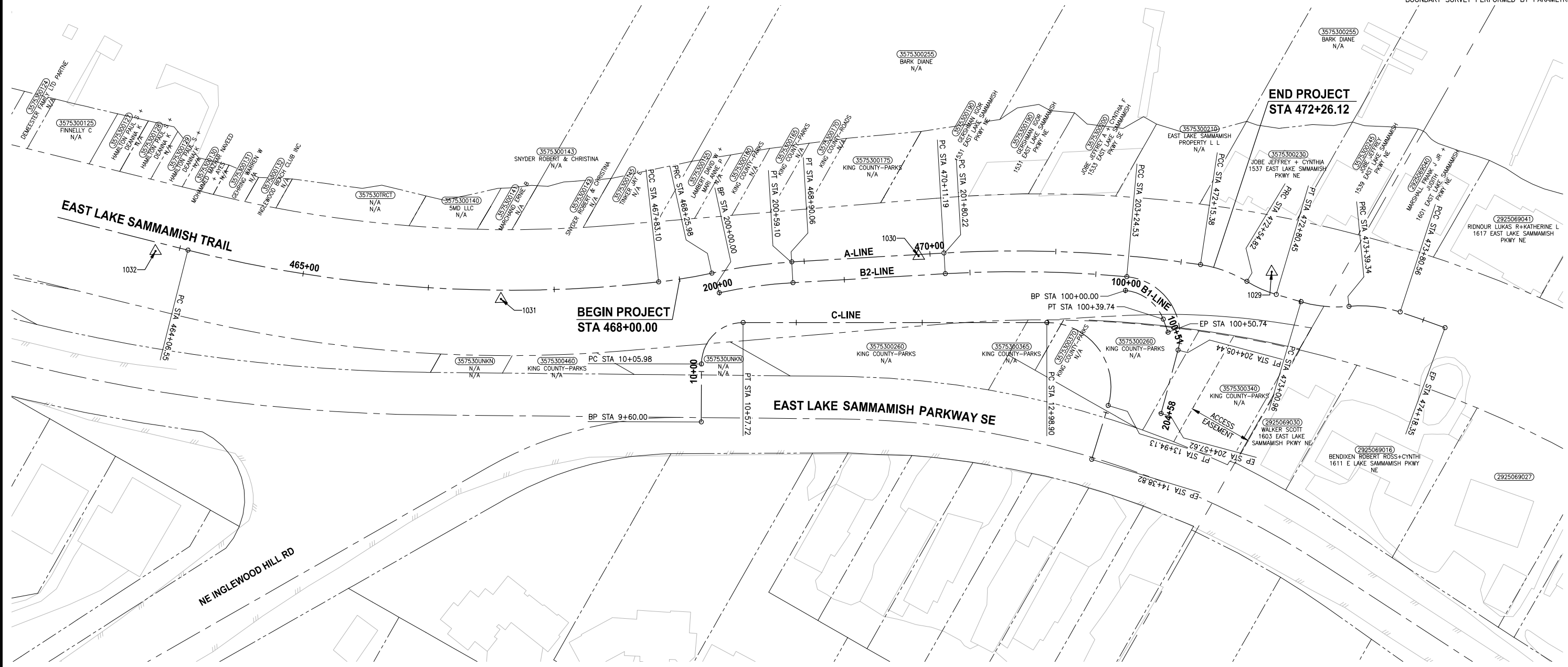

CITY OF SAMMAMISH APPROVAL	
City Engineer _____	Date _____
Community Development _____	Date _____

LAYOUT: G4  
 PATH: U:\PSO\Projects\Clients\1521-075-ELST\995\CA00\Phase 2\103.Dwg  
 PLOTTED BY: purgubut DATE: Tuesday, October 11, 2016 7:48:11 PM

REVISIONS	DATE	BY	DESIGNED
			D. THIBODEAU
			B. PURGANAN
			P. JOHANNESSEN
			Y. HO

**ONE INCH AT FULL SCALE, IF NOT, SCALE ACCORDINGLY**  
 FILE NAME: BL1521075P21T03G-04  
 JOB No: 554-1521-075 P21T03  
 DATE: OCTOBER 2016

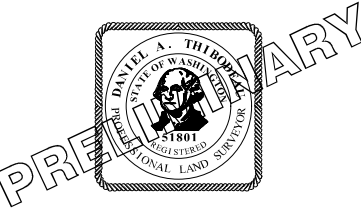

**Parametrix**  
 ENGINEERING · PLANNING · ENVIRONMENTAL SCIENCES  
 719 2ND AVENUE, SUITE 200 | SEATTLE, WA 98104  
 P 206.394.3700  
 WWW.PARAMETRIX.COM

PROJECT NAME  
**EAST LAKE SAMMAMISH MASTER PLAN TRAIL INGLEWOOD HILL ROAD PARKING LOT**  
 SAMMAMISH, WA

**SURVEY CONTROL PLAN**

SHEET NO.  
 4 OF 27  
**G4**

Exhibit 13  
 NOT FOR CONSTRUCTION  
 S5DP2016-00414  
 000179

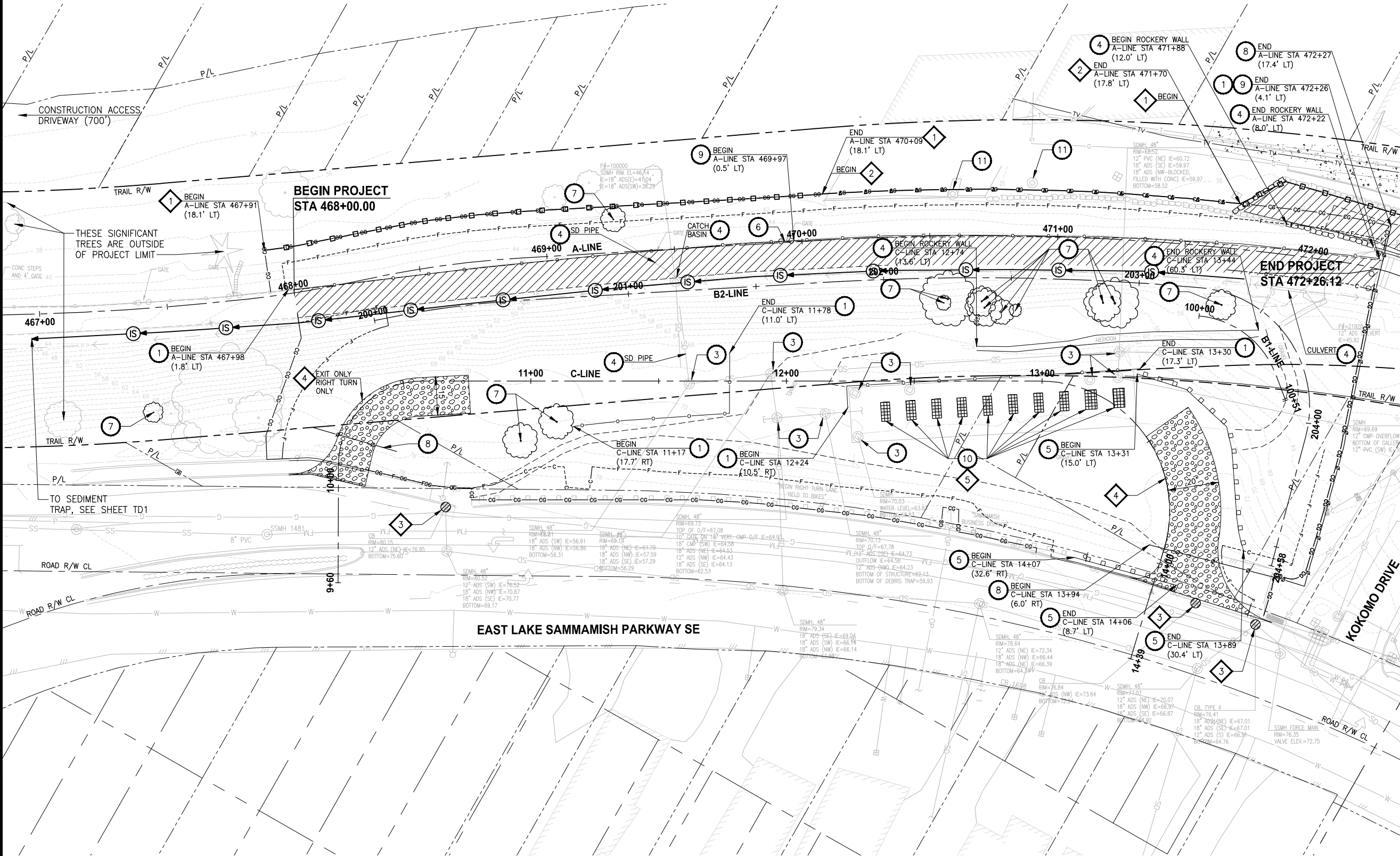

- SITE PREPARATION NOTES:**
- 1 REMOVE AND SALVAGE CHAIN LINK FENCE.
  - 2 REMOVE AND DISPOSE STAIR.
  - 3 ADJUST MANHOLE TO FINISHED GRADE.
  - 4 REMOVAL OF STRUCTURE AND OBSTRUCTION.
  - 5 REMOVE AND SALVAGE GUARDRAILS.
  - 6 REMOVE AND SALVAGE CHAIN LINK GATE.
  - 7 REMOVE TREE OR HEDGE WITHIN CLEARING AND GRUBBING LIMITS.
  - 8 INSTALL TEMPORARY SAFETY FENCE. SEE SPECIAL PROVISIONS.
  - 9 REMOVE AND SALVAGE WOOD BOARD FENCE.
  - 10 ADJUST METAL GRATE TO FINISHED GRADE.
  - 11 PRESERVE AND PROTECT SEWER LINE.

- TESC NOTES:**
- 1 SILT FENCE PER WSDOT STANDARD DETAIL 1-30.15-02.
  - 2 TRIANGLE SILT DIKE.
  - 3 STORM DRAIN INLET PROTECTION, PER WSDOT STANDARD DETAIL 1-40.20-00.
  - 4 STABILIZED CONSTRUCTION ENTRANCE, PER WSDOT STANDARD DETAIL 1-80.10-01.
  - 5 METAL GRATE INLET PROTECTION, SEE DETAIL SHEET TD1.
  - 6 TEMPORARY BYPASS.

- LEGEND:**
- REMOVE EXISTING GRAVEL SURFACE
  - PAVEMENT EXCAVATION LIMIT
  - INLET PROTECTION
  - STABILIZED CONSTRUCTION ENTRANCE
  - NPDES CONSTRUCTION STORMWATER DISCHARGE MONITORING POINT
  - INTERCEPTOR SWALE



CITY OF SAMMAMISH APPROVAL

City Engineer _____	Date _____
Community Development _____	Date _____

**Exhibit 13**  
**NOT FOR CONSTRUCTION**  
**SSDP2016-00414**  
**000180**

REVISIONS	DATE	BY	DESIGNED
			J. JUN
			B. PURGANAN
			P. JOHANNESSEN
			Y. HO

ONE INCH AT FULL SCALE, IF NOT, SCALE ACCORDINGLY

FILE NAME: BL1521075P21T03SP-01  
JOB No.: 554-1521-075 P21T03  
DATE: OCTOBER 2016

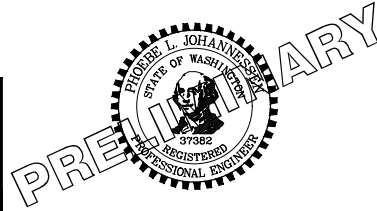

**Parametrix**  
ENGINEERING · PLANNING · ENVIRONMENTAL SCIENCES

719 2ND AVENUE, SUITE 200 | SEATTLE, WA 98104  
P 206.394.3700  
WWW.PARAMETRIX.COM

PROJECT NAME  
**EAST LAKE SAMMAMISH MASTER PLAN TRAIL INGLEWOOD HILL ROAD PARKING LOT**  
SAMMAMISH, WA

**TESC/SITE PREPARATION PLAN**

SHEET NO.  
5 OF 27  
**SP1**

PLOTTED BY: purganab DATE: Tuesday, October 11, 2016 7:48:49 PM  
 PATH: U:\PSO\Projects\Clients\1521-075-ELST\985\SSDP\Phase 21\T03\DWG\



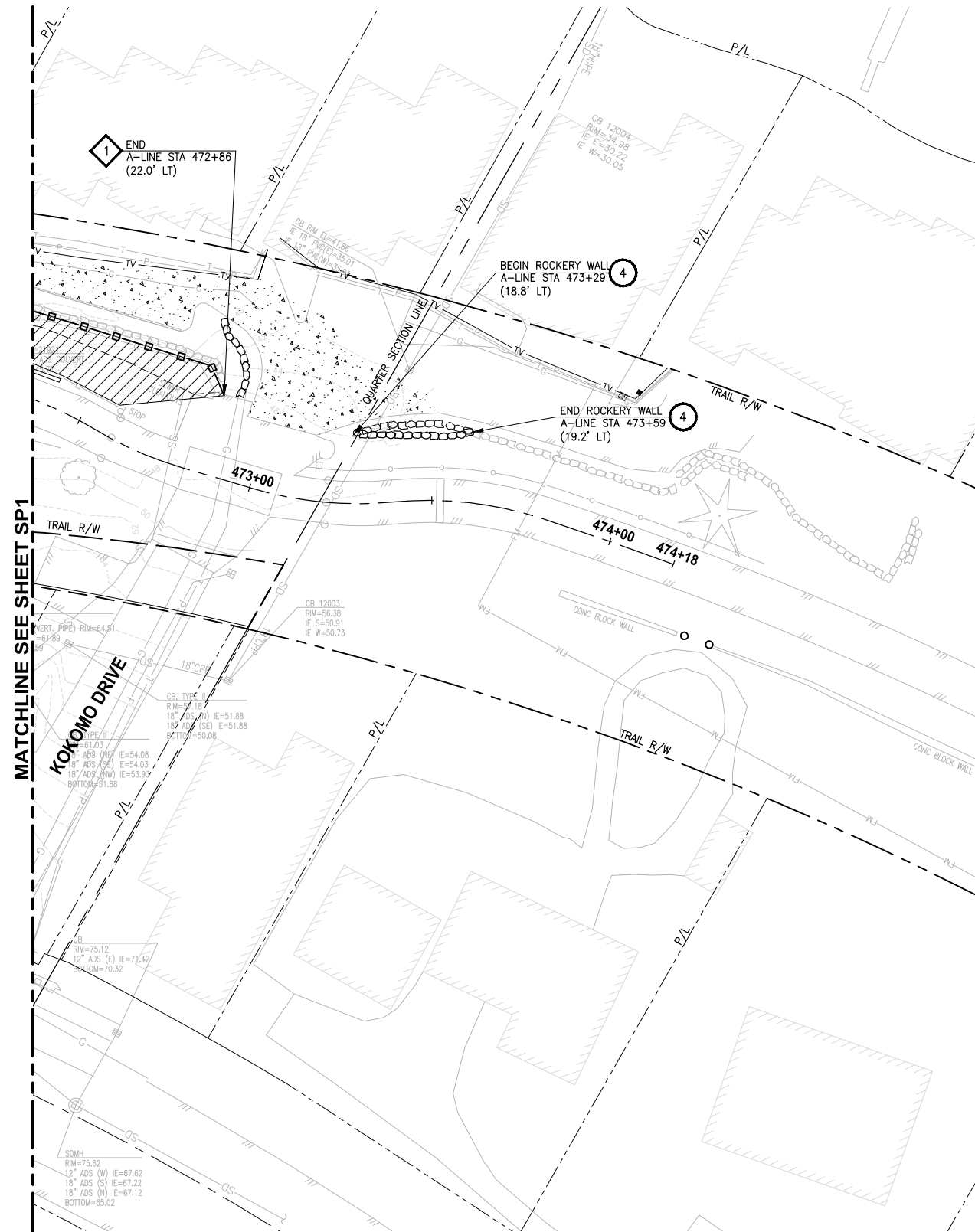

MATCHLINE SEE SHEET SP1

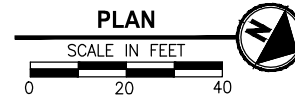

- SITE PREPARATION NOTES:**
- 1 REMOVE AND SALVAGE CHAIN LINK FENCE.
  - 2 REMOVE AND DISPOSE STAIR.
  - 3 ADJUST MANHOLE TO FINISHED GRADE.
  - 4 REMOVAL OF STRUCTURE AND OBSTRUCTION.
  - 5 REMOVE AND SALVAGE GUARDRAILS.
  - 6 REMOVE AND SALVAGE CHAIN LINK GATE.
  - 7 REMOVE TREE OR HEDGE WITHIN CLEARING AND GRUBBING LIMITS.
  - 8 INSTALL TEMPORARY SAFETY FENCE. SEE SPECIAL PROVISIONS.
  - 9 REMOVE AND SALVAGE WOOD BOARD FENCE.
  - 10 ADJUST METAL GRATE TO FINISHED GRADE.
  - 11 PRESERVE AND PROTECT SEWER LINE.

- TESC NOTES:**
- 1 SILT FENCE PER WSDOT STANDARD DETAIL I-30.15-02.
  - 2 TRIANGLE SILT DIKE.
  - 3 STORM DRAIN INLET PROTECTION, PER WSDOT STANDARD DETAIL I-40.20-00.
  - 4 STABILIZED CONSTRUCTION ENTRANCE, PER WSDOT STANDARD DETAIL I-80.10-01.
  - 5 METAL GRATE INLET PROTECTION, SEE DETAIL SHEET TD1.
  - 6 TEMPORARY BYPASS.

- LEGEND:**
- REMOVE EXISTING GRAVEL SURFACE
  - PAVEMENT EXCAVATION LIMIT
  - INLET PROTECTION
  - STABILIZED CONSTRUCTION ENTRANCE
  - NPDES CONSTRUCTION STORMWATER DISCHARGE MONITORING POINT
  - INTERCEPTOR SWALE

CITY OF SAMMAMISH APPROVAL	
City Engineer _____	Date _____
Community Development _____	Date _____

**Exhibit 13**  
NOT FOR CONSTRUCTION  
**SSDP2016-00414**  
**000181**

REVISIONS	DATE	BY	DESIGNED
			J. JUN
			B. PURGANAN
			P. JOHANNESSEN
			Y. HO

**ONE INCH AT FULL SCALE, IF NOT, SCALE ACCORDINGLY**

FILE NAME: BL1521075P21T03SP-01  
 JOB No.: 554-1521-075 P21T03  
 DATE: OCTOBER 2016

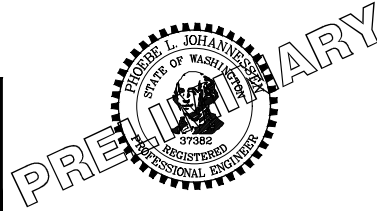

**Parametrix**  
ENGINEERING · PLANNING · ENVIRONMENTAL SCIENCES

719 2ND AVENUE, SUITE 200 | SEATTLE, WA 98104  
 P 206.394.3700  
 WWW.PARAMETRIX.COM

PROJECT NAME  
**EAST LAKE SAMMAMISH  
 MASTER PLAN TRAIL  
 INGLEWOOD HILL ROAD PARKING LOT**  
 SAMMAMISH, WA

**TESC/SITE PREPARATION PLAN**

SHEET NO.  
6 OF 27  
**SP2**

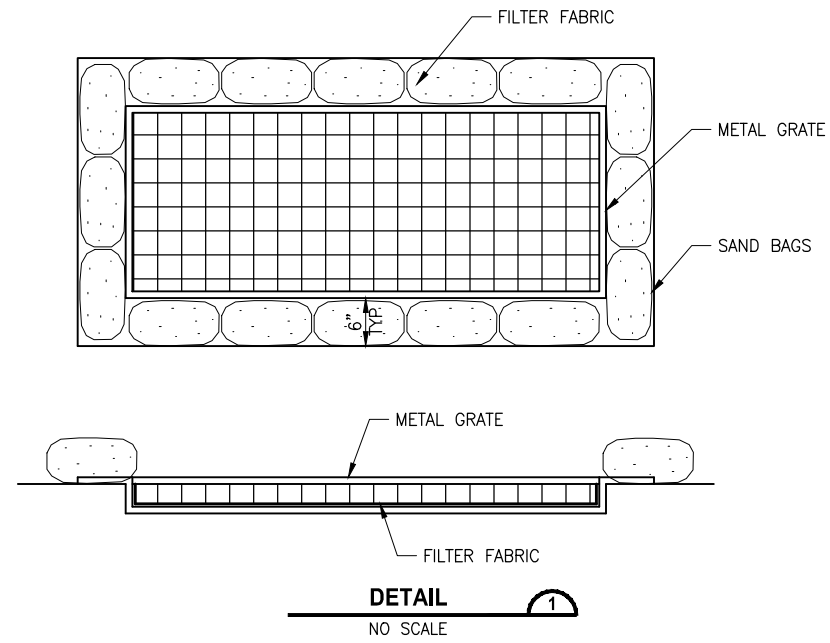

PATH: U:\PSO\Projects\Clients\1521-KingCo\554-1521-075-ELST\98\Sves\CADD\Phase 21\103\DWG\ PLOTTED BY: purgbut DATE: Tuesday, October 11, 2016 7:50:51 PM  
 LAYOUT: TD1

REVISIONS	DATE	BY	DESIGNED
			P. JOHANNESSEN
			DRAWN B. PURGANAN
			CHECKED P. JOHANNESSEN
			APPROVED Y. HO

**ONE INCH AT FULL SCALE.  
 IF NOT, SCALE ACCORDINGLY**  
 FILE NAME  
 BL1521075P21T03TD-01  
 JOB No.  
 554-1521-075 P21T03  
 DATE  
 OCTOBER 2016

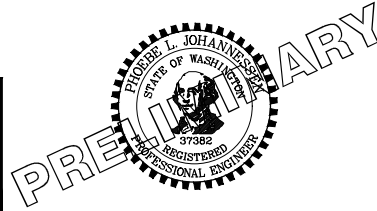

**Parametrix**  
 ENGINEERING · PLANNING · ENVIRONMENTAL SCIENCES  
 719 2ND AVENUE, SUITE 200 | SEATTLE, WA 98104  
 P 206.394.3700  
 WWW.PARAMETRIX.COM

PROJECT NAME  
**EAST LAKE SAMMAMISH  
 MASTER PLAN TRAIL  
 INGLEWOOD HILL ROAD PARKING LOT**  
 SAMMAMISH, WA

**TESC DETAILS**

SHEET NO.  
 7 OF 27  
**TD1**

CITY OF SAMMAMISH APPROVAL	
City Engineer _____	Date _____
Community Development _____	Date _____

**Exhibit 13**  
 NOT FOR CONSTRUCTION  
**SSDP2016-00414**  
**000182**

SEC'S 8, 17 TWP. 24 N., RGE. 06 E, W.M.

CONSTRUCTION NOTES:

- 1 HMA CL. 3/8" PG 64-22.
- 2 5/8" MINUS CRUSHED LEDGE ROCK, COMPACTED DEPTH, 100% FRACTURED. SEE SPECIAL PROVISIONS FOR SPECIFICATIONS.
- 3 STRUCTURAL EARTH WALL, SEE AL PLANS FOR LOCATIONS. SEE WP SHEETS FOR WALL PROFILES. SEE WD SHEET FOR DETAILS.
- 4 NOT USED.
- 5 HANDGRIP.
- 6 SELECT BORROW INCL. HAUL.
- 7 COATED CHAIN LINK FENCE TYPE 6.
- 8 CRUSHED SURFACING BASE COURSE.
- 9 INFILTRATION TRENCH (1 SD1)
- 10 CEMENT CONCRETE SIDEWALK PER WSDOT STD PLAN F-30.10-03.
- 11 CEMENT CONCRETE TRAFFIC CURB AND GUTTER PER WSDOT STD PLAN F-10.12-03.
- 12 METAL HANDRAIL PER KING COUNTY ROAD STD FIG 5-008.
- 13 HMA CL. 1/2" PG 64-22.
- 14 4" TOPSOIL TYPE A, SEEDING, FERTILIZING AND MULCHING.
- 15 PIGMENTED CEMENT CONCRETE PAVEMENT (4"x8" NOMINAL BRICK PATTERN).
- 16 CEMENT CONCRETE TRAFFIC CURB PER WSDOT STD PLAN F-10.12-03.

GENERAL NOTE:

1. APPLY SOIL RESIDUAL HERBICIDE 16-FOOT WIDTH TO THE SURFACE OF THE TRAIL CRUSHED SURFACING BASE COURSE PRIOR TO HMA PAVING.

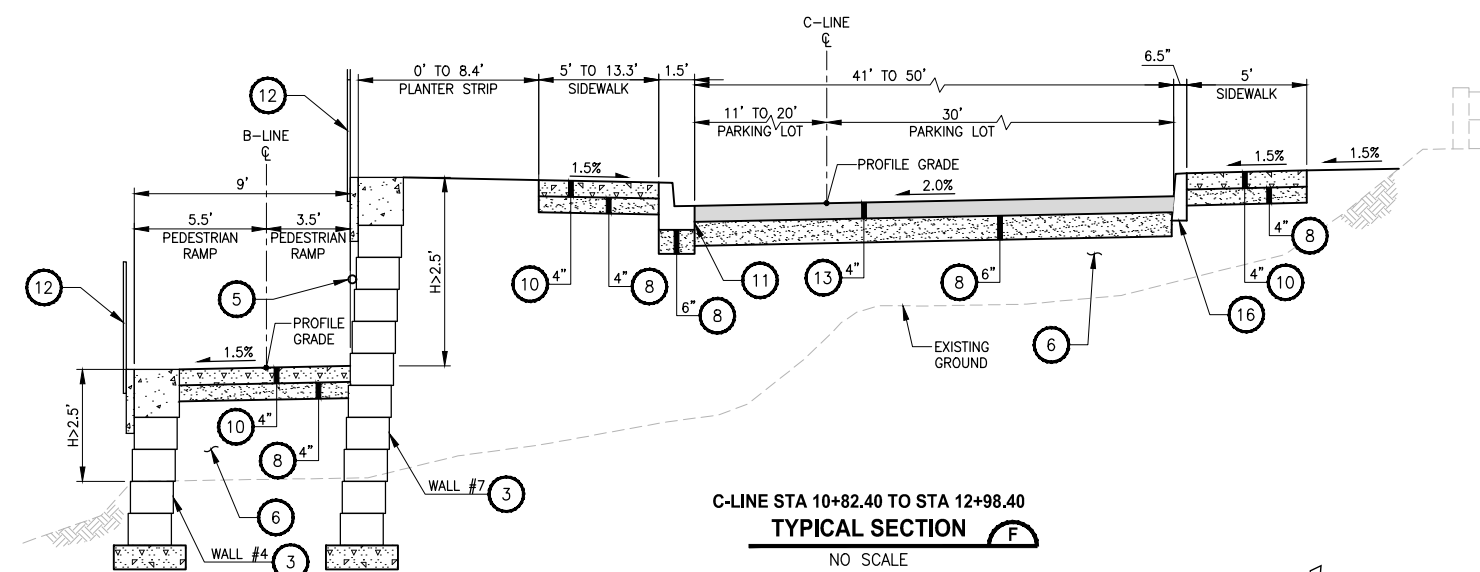
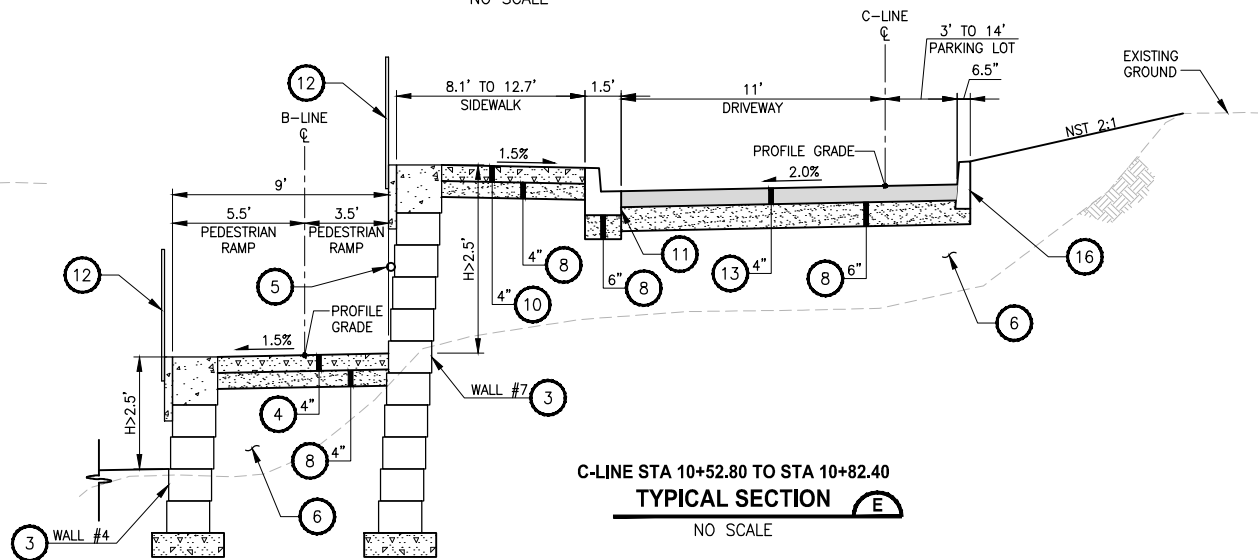
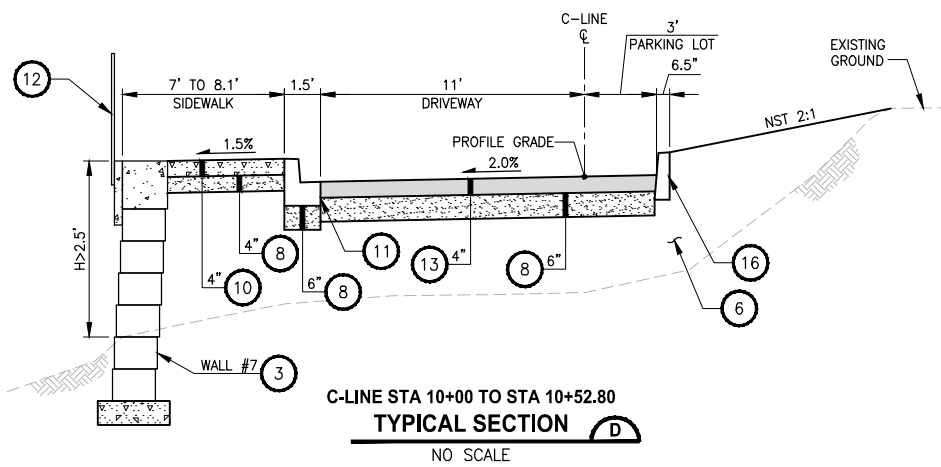
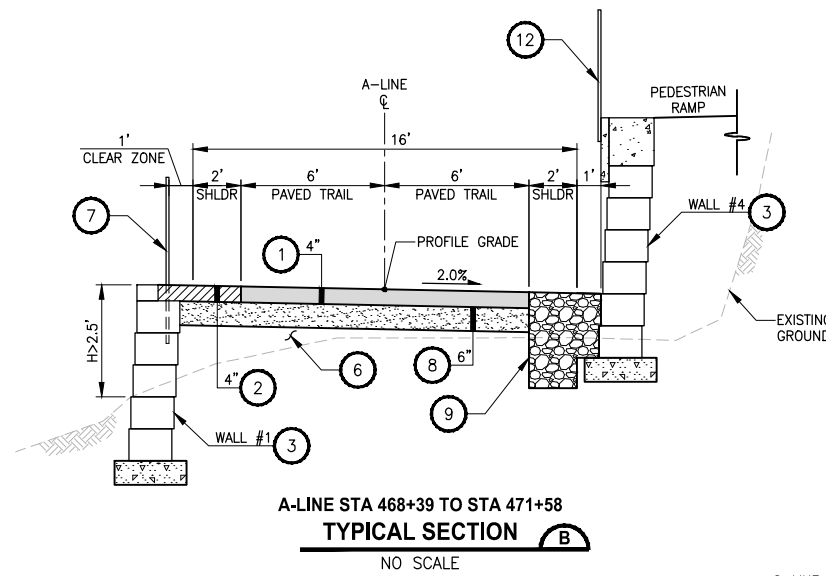
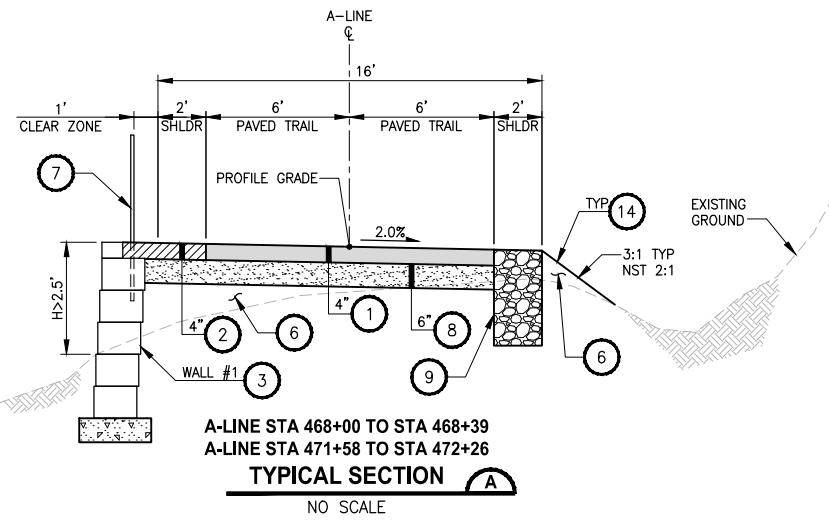

CITY OF SAMMAMISH APPROVAL	
City Engineer _____	Date _____
Community Development _____	Date _____

Exhibit 13  
NOT FOR CONSTRUCTION  
SSDP2016-00414  
000183

LAYOUT: CSI PATH: U:\PSO\Projects\Clients\1521-KingCo\554-1521-075-ELST\98Secs\CADD\Phase 2\103\DWG\ PLOTTED BY: purganub DATE: Tuesday, October 11, 2016 7:51:28 PM

REVISIONS	DATE	BY	DESIGNED
			J. JUN
			B. PURGANAN
			P. JOHANNESSEN
			Y. HO

ONE INCH AT FULL SCALE, IF NOT, SCALE ACCORDINGLY  
FILE NAME: BL1521075P21T03CS-01  
JOB No: 554-1521-075 P21T03  
DATE: OCTOBER 2016

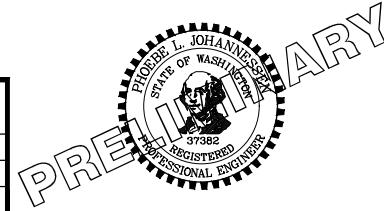

**Parametrix**  
ENGINEERING · PLANNING · ENVIRONMENTAL SCIENCES  
719 2ND AVENUE, SUITE 200 | SEATTLE, WA 98104  
P 206.394.3700  
WWW.PARAMETRIX.COM

PROJECT NAME  
**EAST LAKE SAMMAMISH MASTER PLAN TRAIL INGLEWOOD HILL ROAD PARKING LOT**  
SAMMAMISH, WA

**TYPICAL CROSS SECTIONS**

SHEET NO.  
8 OF 27  
**CS1**

SEC'S 8, 17 TWP. 24 N., RGE. 06 E, W.M.

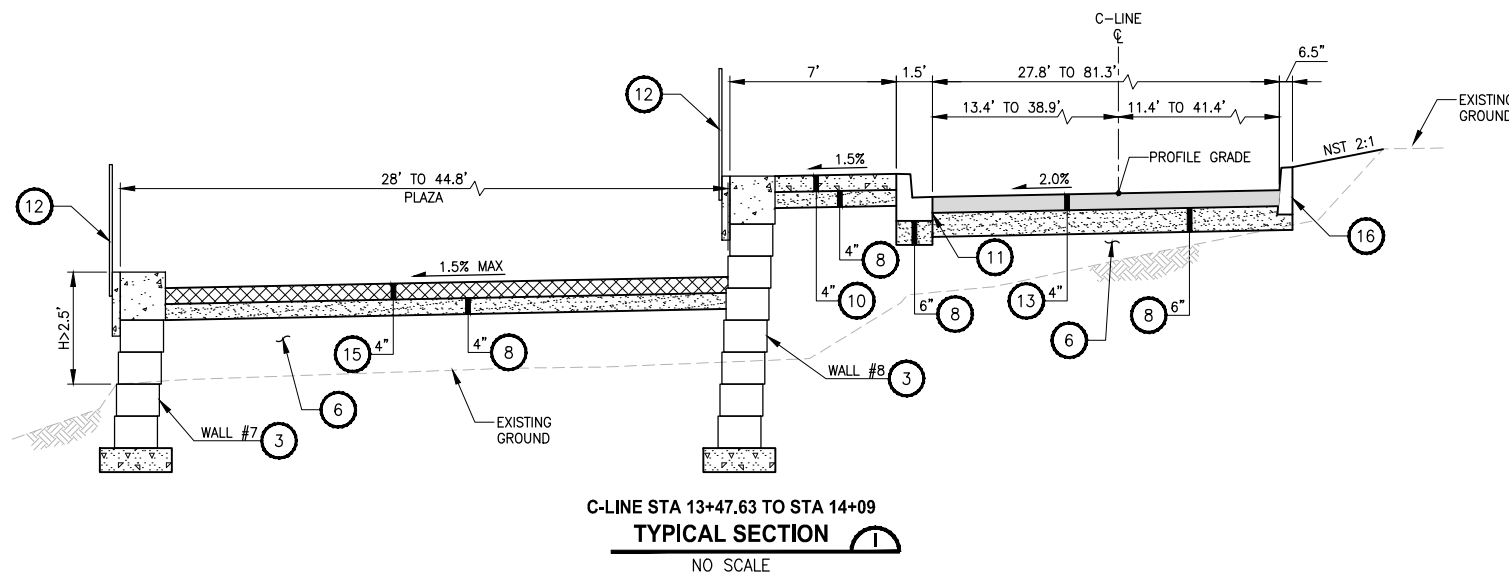
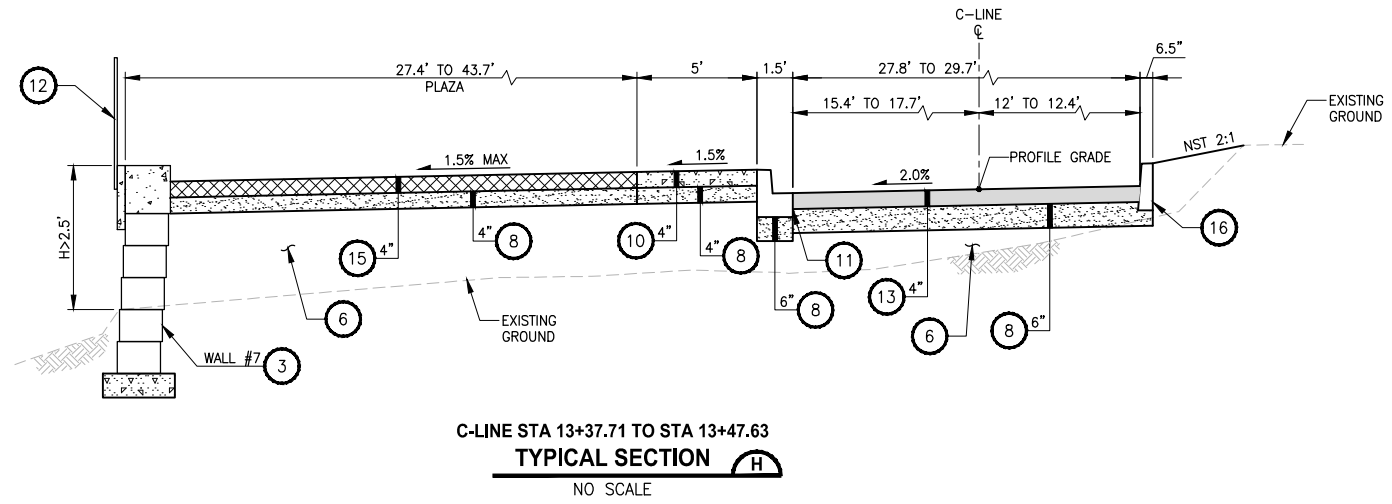
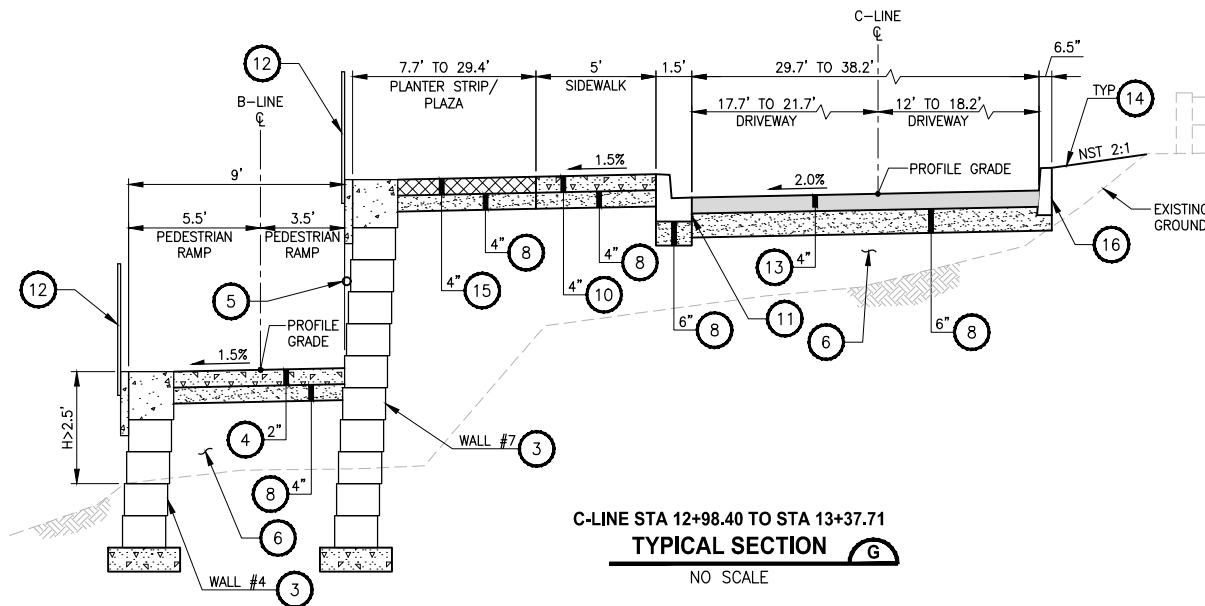

**CONSTRUCTION NOTES:**

- 1 HMA CL. 3/8" PG 64-22.
- 2 5/8" MINUS CRUSHED LEDGE ROCK, COMPACTED DEPTH, 100% FRACTURED. SEE SPECIAL PROVISIONS FOR SPECIFICATIONS.
- 3 STRUCTURAL EARTH WALL, SEE AL PLANS FOR LOCATIONS. SEE WP SHEETS FOR WALL PROFILES. SEE WD SHEET FOR DETAILS.
- 4 NOT USED.
- 5 HANDGRIP.
- 6 SELECT BORROW INCL. HAUL.
- 7 COATED CHAIN LINK FENCE TYPE 6.
- 8 CRUSHED SURFACING BASE COURSE.
- 9 INFILTRATION TRENCH (1 SD1)
- 10 CEMENT CONCRETE SIDEWALK PER WSDOT STD PLAN F-30.10-03.
- 11 CEMENT CONCRETE TRAFFIC CURB AND GUTTER PER WSDOT STD PLAN F-10.12-03.
- 12 METAL HANDRAIL PER KING COUNTY ROAD STD FIG 5-008.
- 13 HMA CL. 1/2" PG 64-22.
- 14 4" TOPSOIL TYPE A, SEEDING, FERTILIZING AND MULCHING.
- 15 PIGMENTED CEMENT CONCRETE PAVEMENT (4"x8" NOMINAL BRICK PATTERN).
- 16 CEMENT CONCRETE TRAFFIC CURB PER WSDOT STD PLAN F-10.12-03.

**GENERAL NOTE:**

1. APPLY SOIL RESIDUAL HERBICIDE 16-FOOT WIDTH TO THE SURFACE OF THE TRAIL CRUSHED SURFACING BASE COURSE PRIOR TO HMA PAVING.

CITY OF SAMMAMISH APPROVAL	
City Engineer _____	Date _____
Community Development _____	Date _____

**Exhibit 13**  
 NOT FOR CONSTRUCTION  
**SSDP2016-00414**  
**000184**

PATH: U:\PSO\Projects\Clients\1521-KingCo\554-1521-075-ELST\99\Secs\CADD\Phase 21\T03\DWG\ PLOTTED BY: purganbut DATE: Tuesday, October 11, 2016 7:51:43 PM LAYOUT: CS2

REVISIONS	DATE	BY	DESIGNED
			J. JUN
			B. PURGANAN
			P. JOHANNESSEN
			Y. HO

ONE INCH AT FULL SCALE.  
 IF NOT, SCALE ACCORDINGLY

FILE NAME: BL1521075P21T03CS-01  
 JOB No: 554-1521-075 P21T03  
 DATE: OCTOBER 2016

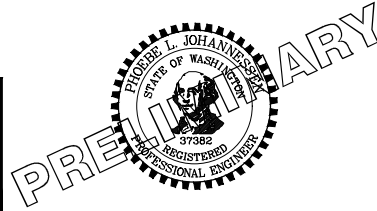

**Parametrix**  
 ENGINEERING · PLANNING · ENVIRONMENTAL SCIENCES

719 2ND AVENUE, SUITE 200 | SEATTLE, WA 98104  
 P 206.394.3700  
 WWW.PARAMETRIX.COM

PROJECT NAME  
**EAST LAKE SAMMAMISH  
 MASTER PLAN TRAIL  
 INGLEWOOD HILL ROAD PARKING LOT**  
 SAMMAMISH, WA

**TYPICAL CROSS SECTIONS**

SHEET NO.  
 9 OF 27  
**CS2**



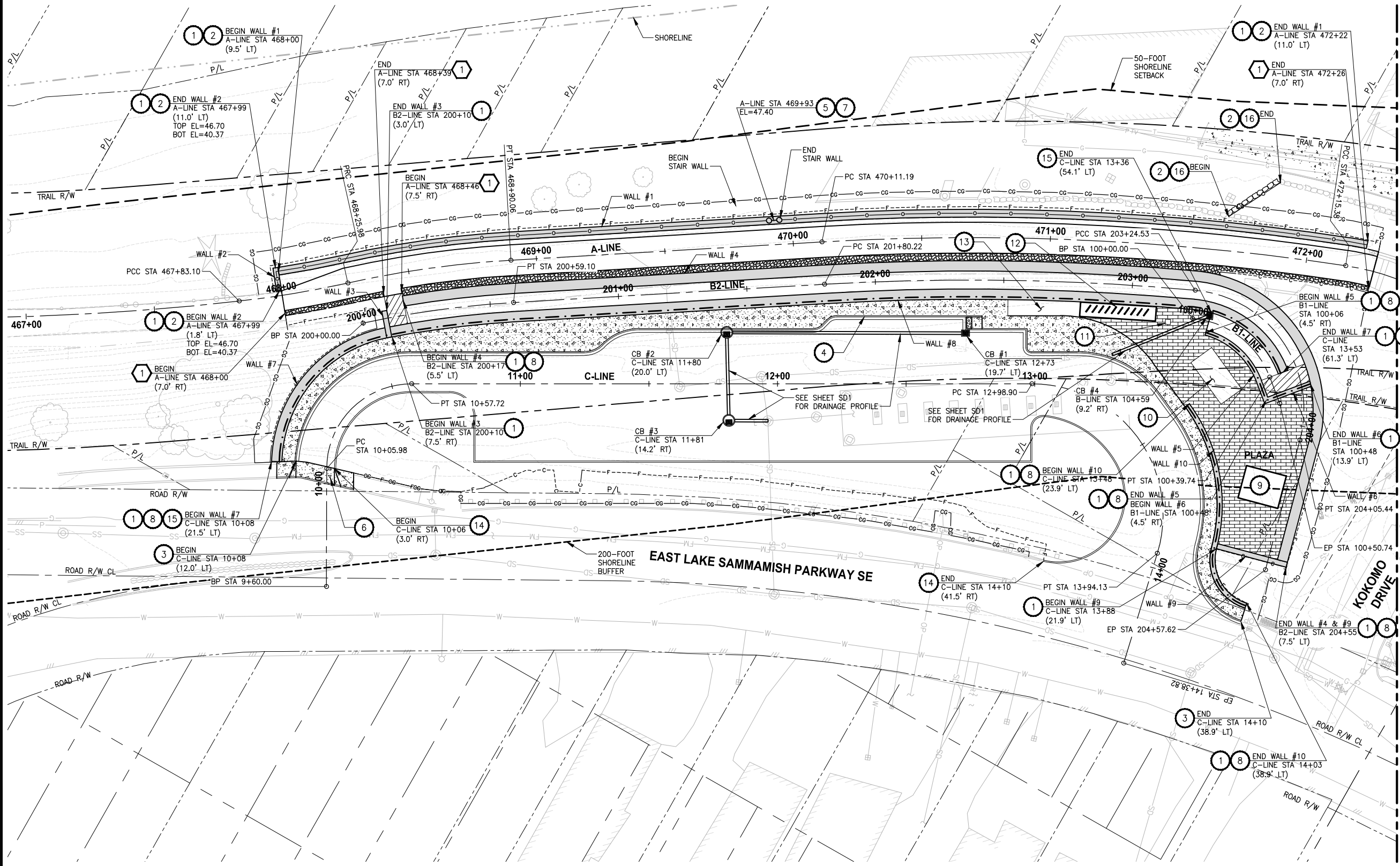

- CIVIL CONSTRUCTION NOTES:**
- 1 INSTALL STRUCTURAL EARTH WALL. SEE WALL DETAILS ON WD SHEETS. SEE WALL PROFILES ON WP SHEETS.
  - 2 INSTALL COATED CHAIN LINK FENCE TYPE 6. FOR GROUND POST INSTALLATION, SEE APPENDIX B IN THE SPECIFICATIONS. SEE WD SHEET FOR MOUNTING ON TOP OF WALL.
  - 3 CEMENT CONCRETE TRAFFIC CURB AND GUTTER PER WSDOT STD PLAN F-10.12-03. SEE DETAILS IN APPENDIX B OF SPECIFICATIONS.
  - 4 PERPENDICULAR CURB RAMP PER WSDOT STD PLAN F-40.15-02. SEE DETAILS IN APPENDIX B OF SPECIFICATIONS.
  - 5 INSTALL CONCRETE STAIR AND PEDESTRIAN HANDRAIL. SEE DETAILS ON MD SHEET.
  - 6 CEMENT CONCRETE DRIVEWAY TYPE A PER CITY OF SAMMAMISH DEPARTMENT OF PUBLIC WORKS STD PLAN FIG 02-07.
  - 7 INSTALL CHAIN LINK CANTILEVER GATE. SEE DETAIL ON SHEET MD1.
  - 8 INSTALL METAL HANDRAIL PER KING COUNTY ROAD STD FIG. 5-008.
  - 9 PUBLIC RESTROOM (TO BE DESIGNED BY OTHERS).
  - 10 COVERED PICNIC TABLE AREA.
  - 11 KIOSK CONCRETE PAD. KIOSK SHALL BE PROVIDED BY THE COUNTY.
  - 12 SHELTERED BIKE PARKING.
  - 13 PLANTER, SEE SHEET PS1 FOR DETAILS.
  - 14 CEMENT CONCRETE TRAFFIC CURB PER WSDOT STD PLAN F-10.12-03.
  - 15 TRAFFIC CAST IN PLACE TRAFFIC BARRIER.
  - 16 ROCK WALL.

- STORMWATER CONSTRUCTION NOTES:**
- 1 INFILTRATION TRENCH, SEE DETAIL 1 ON SHEET SD1.

**LEGEND:**

- RETAINING WALL
- CEMENT CONCRETE SIDEWALK
- DETECTABLE WARNING SURFACE PER WSDOT STD PLAN F-45.10-01.
- LANDING
- PIGMENTED CEMENT CONCRETE PAVEMENT (4"X8" BRICK PATTERN)

CITY OF SAMMAMISH APPROVAL

City Engineer _____	Date _____
Community Development _____	Date _____

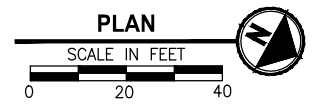

PLOTTED BY: purgaban DATE: Tuesday, October 11, 2016 7:54:35 PM  
 PATH: U:\PSO\Projects\Clients\1521-075-ELST\98\Sves\CADD\Phase 21\103\DWG\

REVISIONS	DATE	BY	DESIGNED
			J. JUN
			B. PURGANAN
			P. JOHANNESSEN
			Y. HO

ONE INCH AT FULL SCALE, IF NOT, SCALE ACCORDINGLY

FILE NAME: BL1521075P21T03AL-01  
 JOB No.: 554-1521-075 P21T03  
 DATE: OCTOBER 2016

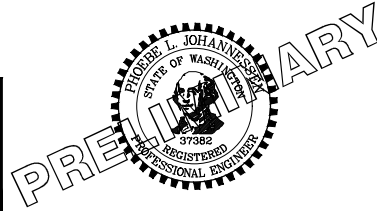

**Parametrix**  
 ENGINEERING · PLANNING · ENVIRONMENTAL SCIENCES

719 2ND AVENUE, SUITE 200 | SEATTLE, WA 98104  
 P 206.394.3700  
 WWW.PARAMETRIX.COM

PROJECT NAME  
**EAST LAKE SAMMAMISH MASTER PLAN TRAIL INGLEWOOD HILL ROAD PARKING LOT**  
 SAMMAMISH, WA

**PARKING LOT PLAN**

SHEET NO.  
 10 OF 27  
**AL1**

**Exhibit 13**  
 NOT FOR CONSTRUCTION  
**SSDP2016-00414**  
**000185**

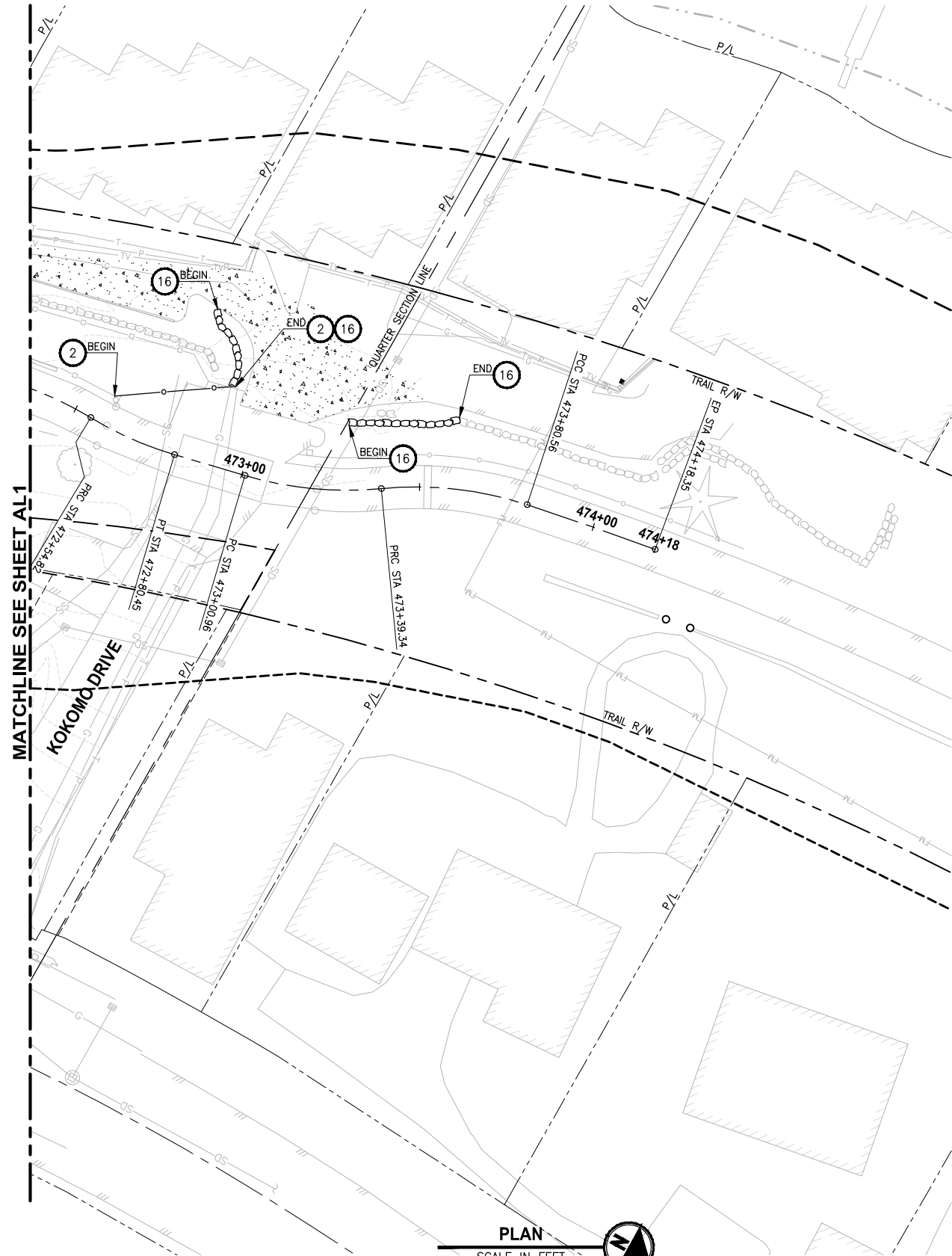

MATCHLINE SEE SHEET AL1

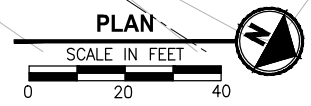

- CIVIL CONSTRUCTION NOTES:**
- 1 INSTALL STRUCTURAL EARTH WALL. SEE WALL DETAILS ON WD SHEETS. SEE WALL PROFILES ON WP SHEETS.
  - 2 INSTALL COATED CHAIN LINK FENCE TYPE 6. FOR GROUND POST INSTALLATION, SEE APPENDIX B IN THE SPECIFICATIONS. SEE WD SHEET FOR MOUNTING ON TOP OF WALL.
  - 3 CEMENT CONCRETE TRAFFIC CURB AND GUTTER PER WSDOT STD PLAN F-10.12-03. SEE DETAILS IN APPENDIX B OF SPECIFICATIONS.
  - 4 PERPENDICULAR CURB RAMP PER WSDOT STD PLAN F-40.15-02. SEE DETAILS IN APPENDIX B OF SPECIFICATIONS.
  - 5 INSTALL CONCRETE STAIR AND PEDESTRIAN HANDRAIL. SEE DETAILS ON MD SHEET.
  - 6 CEMENT CONCRETE DRIVEWAY TYPE A PER CITY OF SAMMAMISH DEPARTMENT OF PUBLIC WORKS STD PLAN FIG 02-07.
  - 7 INSTALL CHAIN LINK CANTILEVER GATE. SEE DETAIL ON SHEET MD1.
  - 8 INSTALL METAL HANDRAIL PER KING COUNTY ROAD STD FIG. 5-008.
  - 9 PUBLIC RESTROOM (TO BE DESIGNED BY OTHERS).
  - 10 COVERED PICNIC TABLE AREA.
  - 11 KIOSK CONCRETE PAD. KIOSK SHALL BE PROVIDED BY THE COUNTY.
  - 12 SHELTERED BIKE PARKING.
  - 13 PLANTER, SEE SHEET PS1 FOR DETAILS.
  - 14 CEMENT CONCRETE TRAFFIC CURB PER WSDOT STD PLAN F-10.12-03.
  - 15 TRAFFIC CAST IN PLACE TRAFFIC BARRIER.
  - 16 ROCK WALL.

- STORMWATER CONSTRUCTION NOTES:**
- 1 INFILTRATION TRENCH, SEE DETAIL 1 ON SHEET SD1.

- LEGEND:**
- RETAINING WALL
  - CEMENT CONCRETE SIDEWALK
  - DETECTABLE WARNING SURFACE PER WSDOT STD PLAN F-45.10-01.
  - LANDING
  - PIGMENTED CEMENT CONCRETE PAVEMENT (4"X8" BRICK PATTERN)

CITY OF SAMMAMISH APPROVAL	
City Engineer _____	Date _____
Community Development _____	Date _____

**Exhibit 13**  
NOT FOR CONSTRUCTION  
**SSDP2016-00414**  
**000186**

REVISIONS	DATE	BY	DESIGNED
			J. JUN
			B. PURGANAN
			P. JOHANNESSEN
			Y. HO

**ONE INCH AT FULL SCALE, IF NOT, SCALE ACCORDINGLY**

FILE NAME: BL1521075P21T03AL-01  
 JOB No.: 554-1521-075 P21T03  
 DATE: OCTOBER 2016

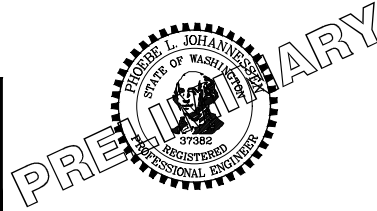

**Parametrix**  
ENGINEERING · PLANNING · ENVIRONMENTAL SCIENCES

719 2ND AVENUE, SUITE 200 | SEATTLE, WA 98104  
 P 206.394.3700  
 WWW.PARAMETRIX.COM

PROJECT NAME  
**EAST LAKE SAMMAMISH  
 MASTER PLAN TRAIL  
 INGLEWOOD HILL ROAD PARKING LOT**  
 SAMMAMISH, WA

**PARKING LOT PLAN**

SHEET NO.  
11 OF 27  
**AL2**

LAYOUT: AL2 PATH: U:\PSO\Projects\Clients\1521-KingCo\554-1521-075-ELST\99Svcs\CADD\Phase 21\T03\DWG\ PLOTTED BY: purgabut DATE: Tuesday, October 11, 2016 7:54:54 PM



SEC'S 8, 17 TWP. 24 N., RGE. 06 E, W.M.

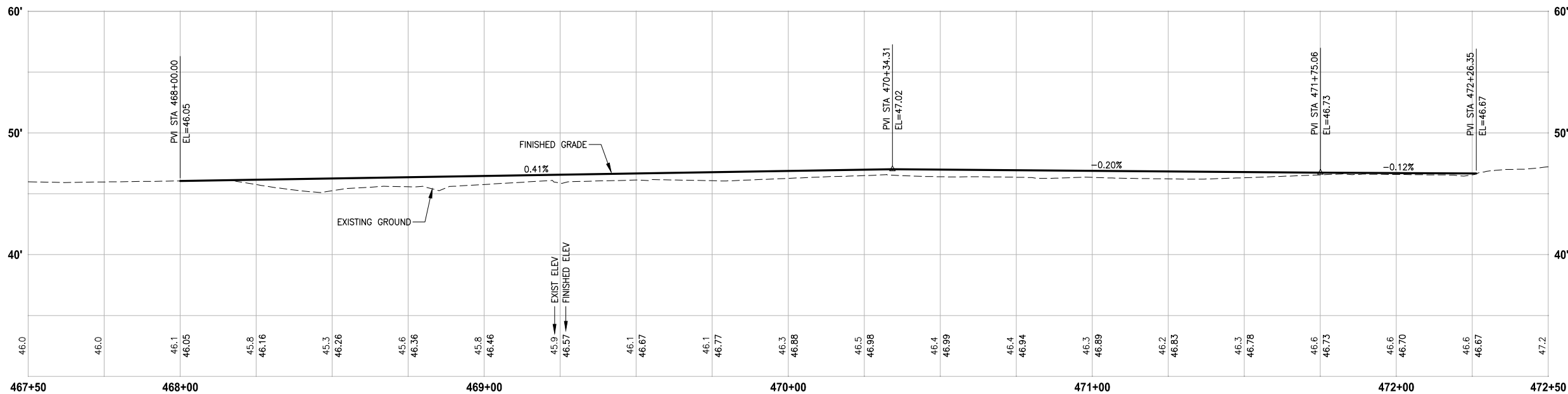

A-LINE PROFILE

HORIZ: 1"=20'  
VERT: 1"=5'

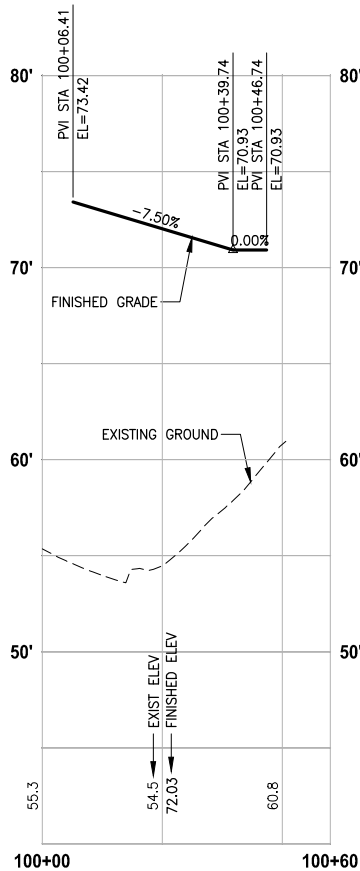

B1-LINE PROFILE

HORIZ: 1"=20'  
VERT: 1"=5'

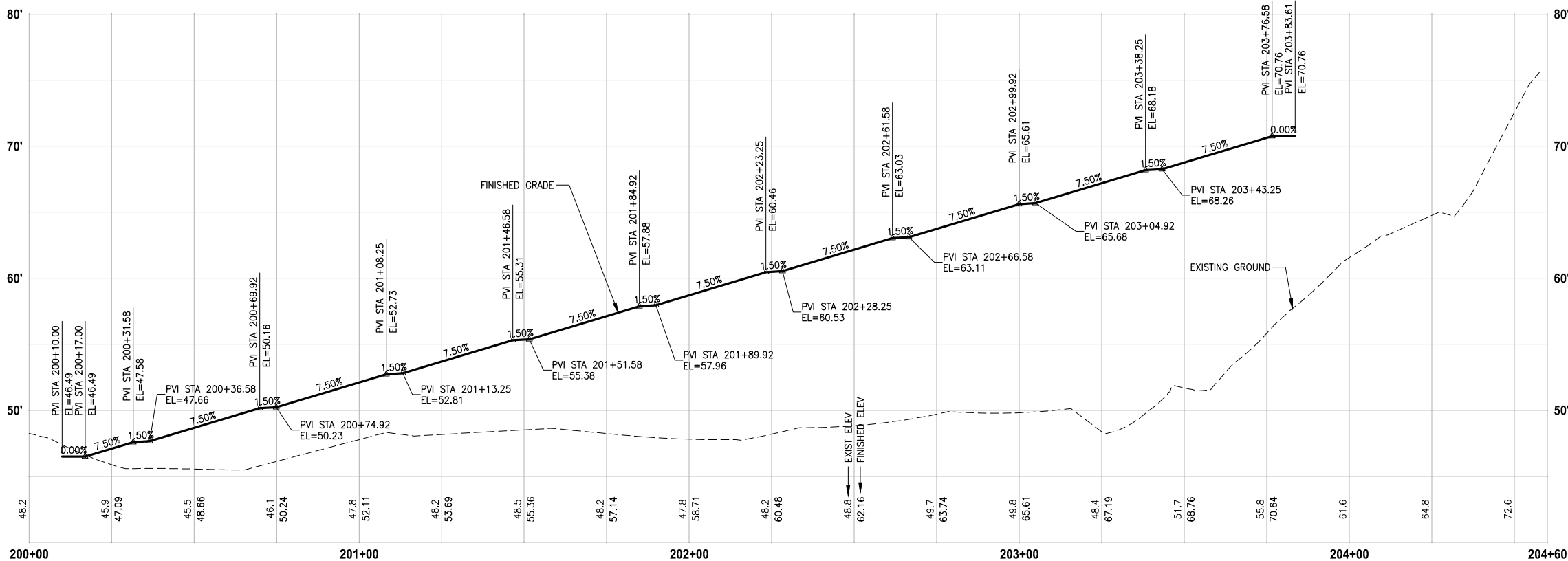

B2-LINE PROFILE

HORIZ: 1"=20'  
VERT: 1"=5'

CITY OF SAMMAMISH APPROVAL	
City Engineer _____	Date _____
Community Development _____	Date _____

PATH: U:\P50\Projects\Clients\1521-075-ELST\99Secs\CADD\Phase 2\1\T03\DWG\ LAYOUT: AL3 PLOTTED BY: purgaban DATE: Tuesday, October 11, 2016 7:55:10 PM

REVISIONS	DATE	BY	DESIGNED
			J. JUN
			B. PURGANAN
			P. JOHANNESSEN
			Y. HO

ONE INCH AT FULL SCALE, IF NOT, SCALE ACCORDINGLY  
FILE NAME: BL1521075P21T03AL-01  
JOB No.: 554-1521-075 P21T03  
DATE: OCTOBER 2016

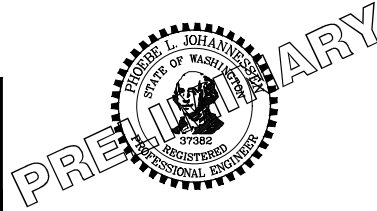

**Parametrix**  
ENGINEERING · PLANNING · ENVIRONMENTAL SCIENCES  
719 2ND AVENUE, SUITE 200 | SEATTLE, WA 98104  
P 206.394.3700  
WWW.PARAMETRIX.COM

PROJECT NAME  
**EAST LAKE SAMMAMISH  
MASTER PLAN TRAIL  
INGLEWOOD HILL ROAD PARKING LOT**  
SAMMAMISH, WA

**PARKING LOT PROFILE**

SHEET NO.  
12 OF 27  
**AL3**

Exhibit 13  
NOT FOR CONSTRUCTION  
SSDP2016-00414  
000187

SEC'S 8, 17 TWP. 24 N., RGE. 06 E, W.M.

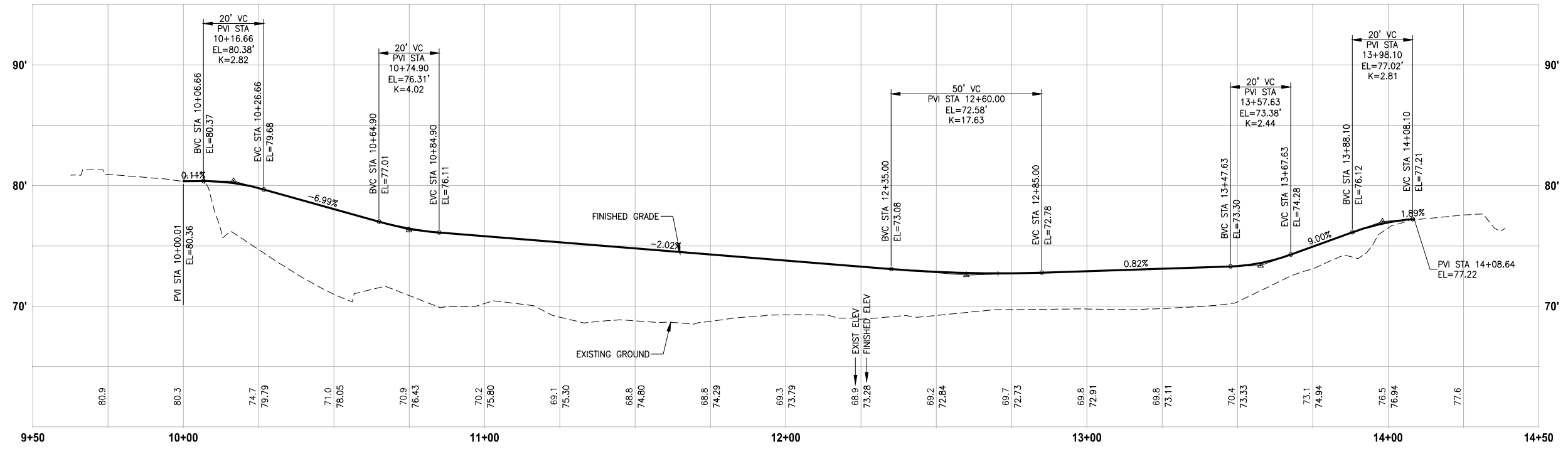

**C-LINE PROFILE**  
 HORIZ: 1"=20'  
 VERT: 1"=5'

PATH: U:\P50\Projects\Clients\1521-KingCo\554-1521-075-ELST\99Secs\CADD\Phase 21\103\DWG\ PLOTTED BY: purgabut DATE: Tuesday, October 11, 2016 7:55:24 PM LAYOUT: AL4

CITY OF SAMMAMISH APPROVAL	
City Engineer _____	Date _____
Community Development _____	Date _____

**Exhibit 13**  
 NOT FOR CONSTRUCTION  
**SSDP2016-00414**  
**000188**

REVISIONS	DATE	BY	DESIGNED
			J. JUN
			B. PURGANAN
			P. JOHANNESSEN
			Y. HO

ONE INCH AT FULL SCALE.  
 IF NOT, SCALE ACCORDINGLY

FILE NAME  
 BL1521075P21T03AL-01

JOB No.  
 554-1521-075 P21T03

DATE  
 OCTOBER 2016

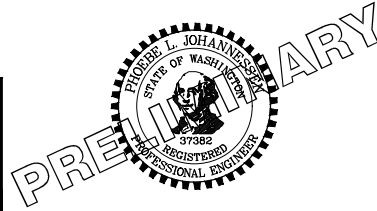

**Parametrix**  
 ENGINEERING · PLANNING · ENVIRONMENTAL SCIENCES

719 2ND AVENUE, SUITE 200 | SEATTLE, WA 98104  
 P 206.394.3700  
 WWW.PARAMETRIX.COM

PROJECT NAME  
**EAST LAKE SAMMAMISH  
 MASTER PLAN TRAIL  
 INGLEWOOD HILL ROAD PARKING LOT**  
 SAMMAMISH, WA

**PARKING LOT PROFILE**

SHEET NO.  
 13 OF 27

**AL4**

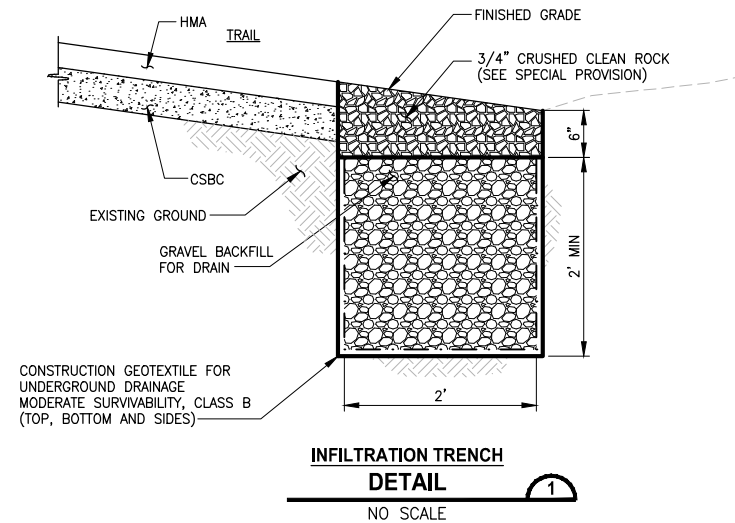
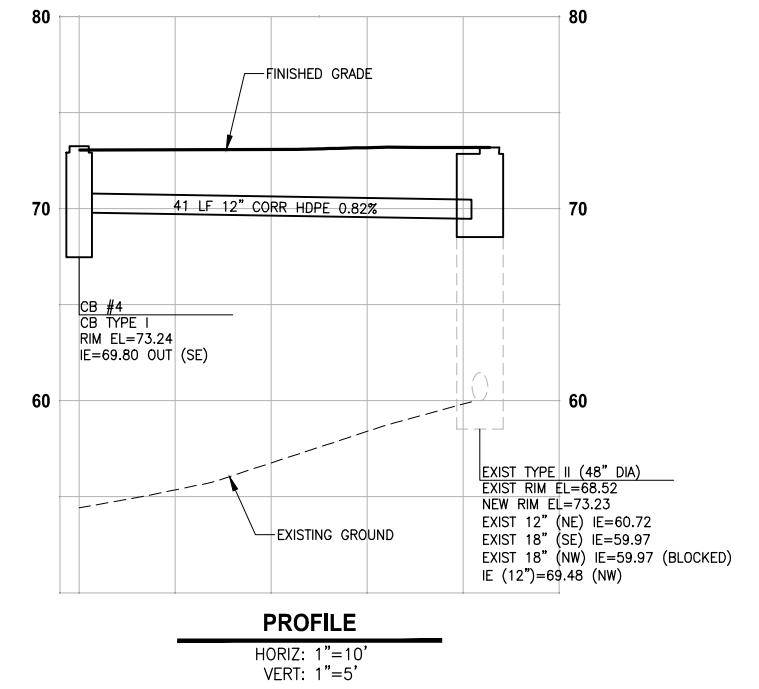
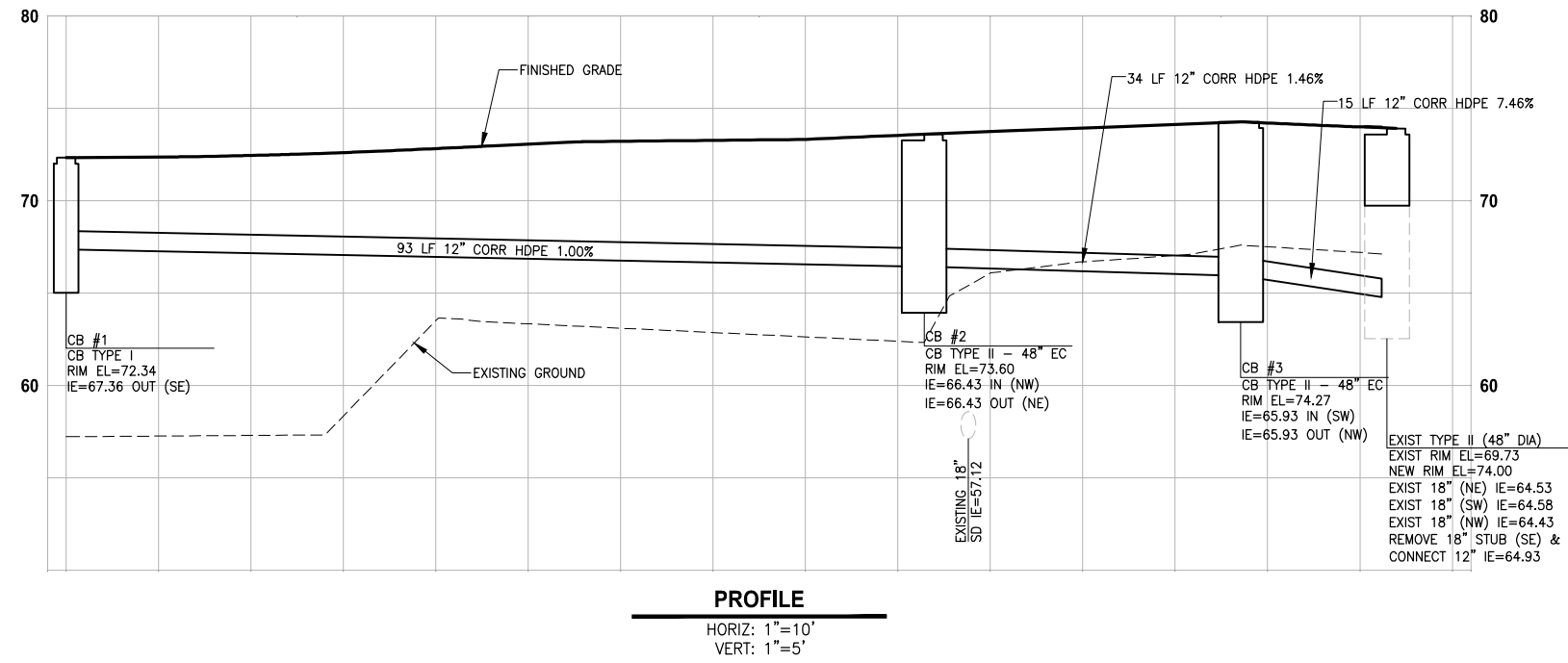

PATH: U:\P50\Projects\Clients\1521-075-ELST\985Secs\CADD\Phase 21\103\DWG\ PLOTTED BY: purganan DATE: Tuesday, October 11, 2016 7:56:56 PM  
 LAYOUT: SD1

REVISIONS	DATE	BY	DESIGNED
			P. JOHANNESSEN
			B. PURGANAN
			P. JOHANNESSEN
			Y. HO

**ONE INCH AT FULL SCALE, IF NOT, SCALE ACCORDINGLY**  
 FILE NAME: BL1521075P21T03SD-01  
 JOB No.: 554-1521-075 P21T03  
 DATE: OCTOBER 2016

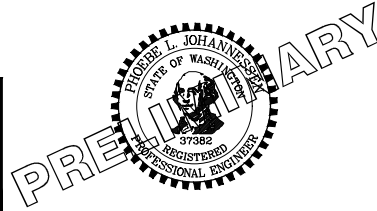

**Parametrix**  
 ENGINEERING · PLANNING · ENVIRONMENTAL SCIENCES  
 719 2ND AVENUE, SUITE 200 | SEATTLE, WA 98104  
 P 206.394.3700  
 WWW.PARAMETRIX.COM

PROJECT NAME  
**EAST LAKE SAMMAMISH MASTER PLAN TRAIL INGLEWOOD HILL ROAD PARKING LOT**  
 SAMMAMISH, WA

**DRAINAGE PROFILES AND DETAILS**

SHEET NO.  
 14 OF 27  
**SD1**

CITY OF SAMMAMISH APPROVAL	
City Engineer _____	Date _____
Community Development _____	Date _____

**Exhibit 13**  
**NOT FOR CONSTRUCTION**  
**SSDP2016-00414**  
**000189**

SEC'S 8, 17 TWP. 24 N., RGE. 06 E, W.M.

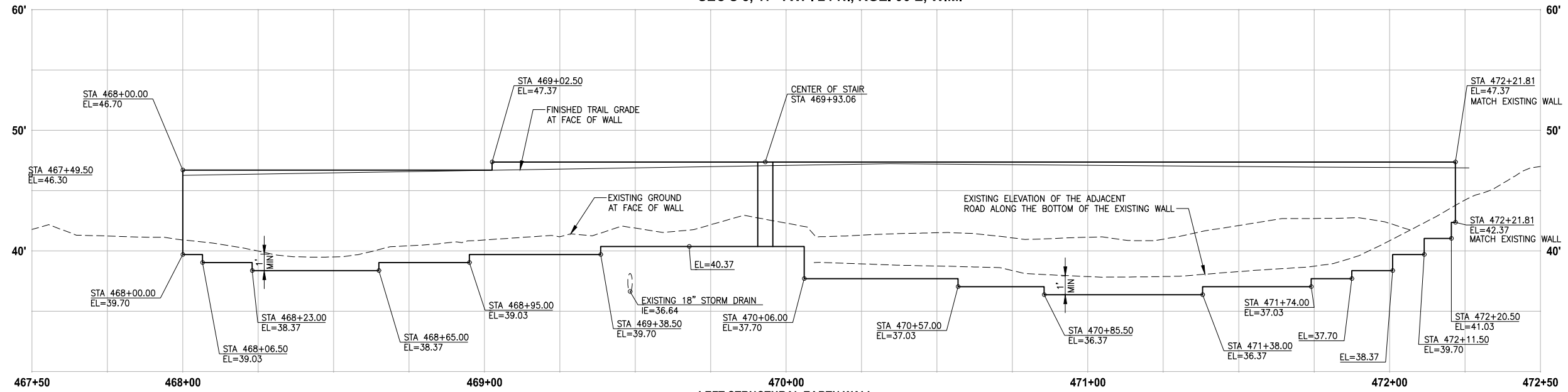

**LEFT STRUCTURAL EARTH WALL  
WALL #1 (FILL) A-LINE**

HORIZ: 1"=20'  
VERT: 1"=5'

**NOTE:**  
1. UTILITIES SHOWN ARE APPROXIMATE. CONTRACTOR TO VERIFY LOCATIONS AND DEPTH, AS AUTHORIZED BY THE ENGINEER.

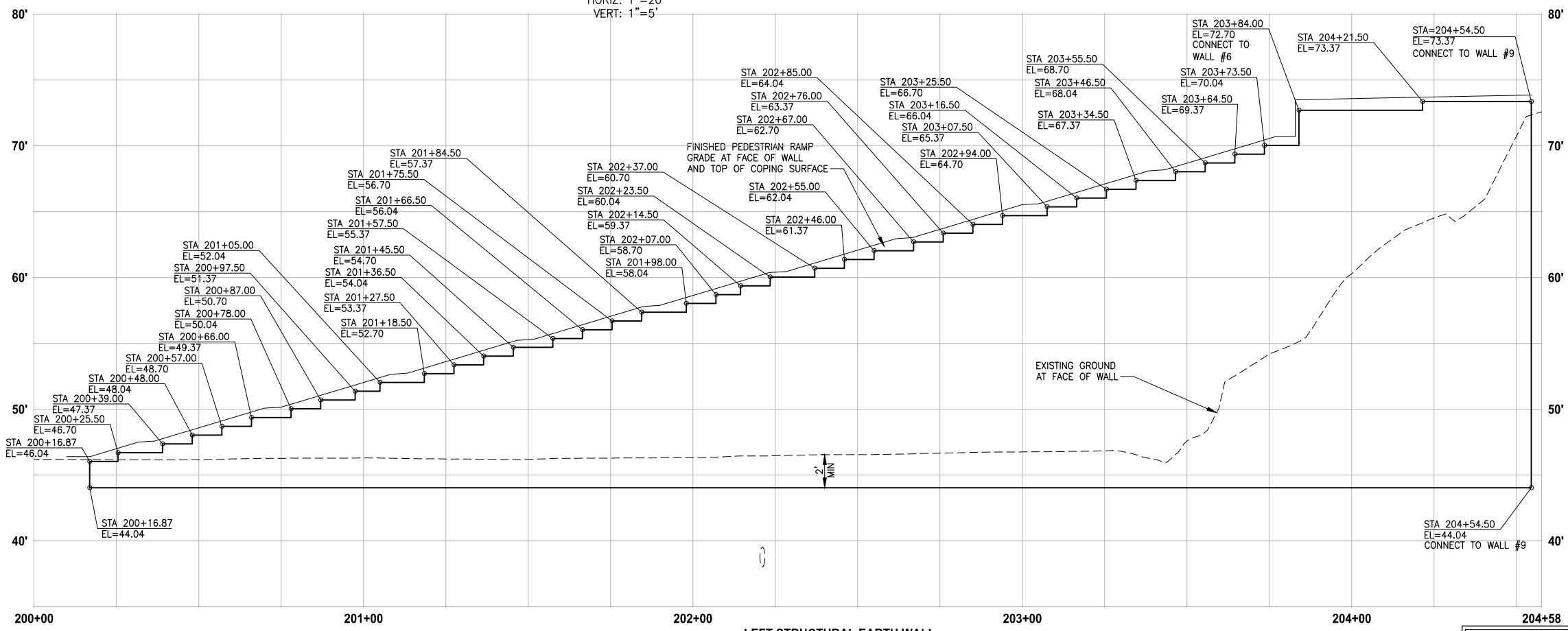

**LEFT STRUCTURAL EARTH WALL  
WALL #4 (FILL) B2-LINE**

HORIZ: 1"=20'  
VERT: 1"=5'

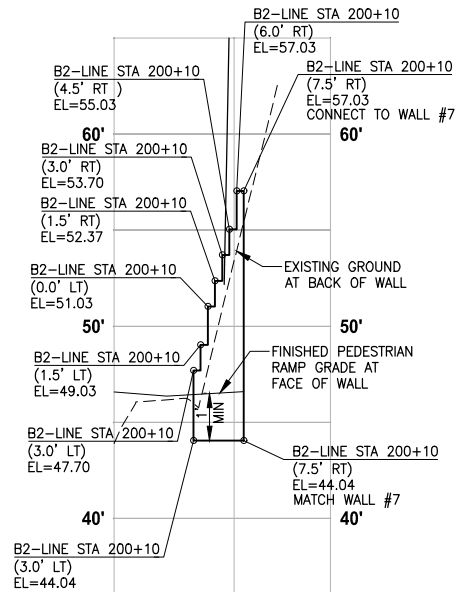

**STRUCTURAL EARTH WALL  
WALL #3 (CUT) B2-LINE**

HORIZ: 1"=20'  
VERT: 1"=5'

CITY OF SAMMAMISH APPROVAL	
City Engineer _____	Date _____
Community Development _____	Date _____

**Exhibit 13**  
**NOT FOR CONSTRUCTION**  
**SSDP2016-00414**  
**000190**

PATH: U:\PSO\Projects\Clients\1521-KingCo\554-1521-075-ELST\99Sves\CA600 Phase 21\T03\DWG\ PLOTTED BY: purgabut DATE: Tuesday, October 11, 2016 7:58:11 PM LAYOUT: WP1

REVISIONS	DATE	BY	DESIGNED
			J. JUN
			B. PURGANA
			P. JOHANNESSEN
			Y. HO

**ONE INCH AT FULL SCALE,  
IF NOT, SCALE ACCORDINGLY**

FILE NAME  
BL1521075P21T03WP-01  
JOB No.  
554-1521-075 P21T03  
DATE  
OCTOBER 2016

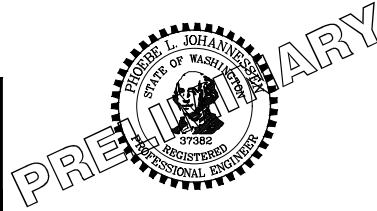

**Parametrix**  
ENGINEERING · PLANNING · ENVIRONMENTAL SCIENCES

719 2ND AVENUE, SUITE 200 | SEATTLE, WA 98104  
P 206.394.3700  
WWW.PARAMETRIX.COM

PROJECT NAME  
**EAST LAKE SAMMAMISH  
MASTER PLAN TRAIL  
INGLEWOOD HILL ROAD PARKING LOT**  
SAMMAMISH, WA

**WALL PROFILES**

SHEET NO.  
15 OF 27  
**WP1**

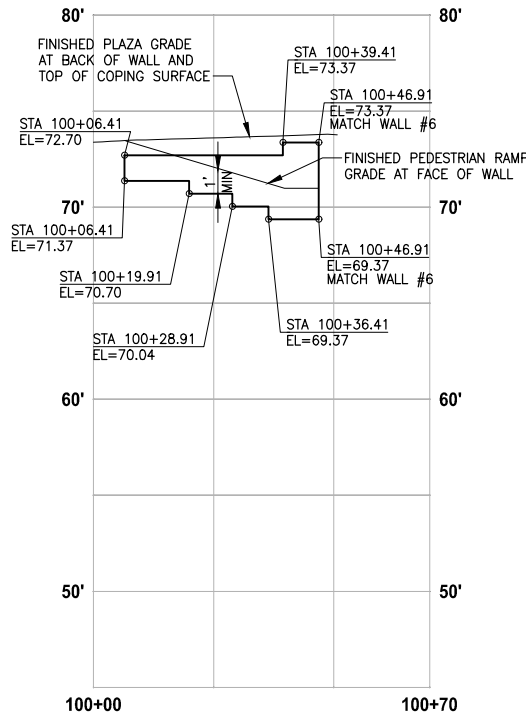

**LEFT STRUCTURAL EARTH WALL  
WALL #5 (CUT) B1-LINE**

HORIZ: 1"=20'  
VERT: 1"=5'

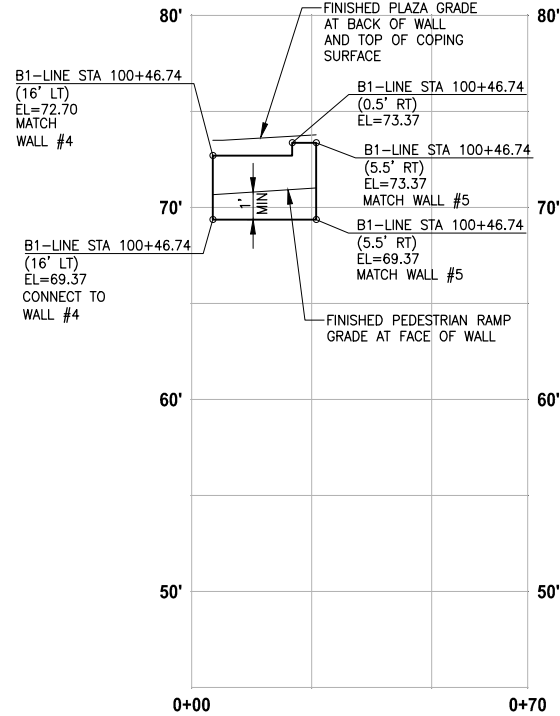

**STRUCTURAL EARTH WALL  
WALL #6 (CUT) B1-LINE**

HORIZ: 1"=20'  
VERT: 1"=5'

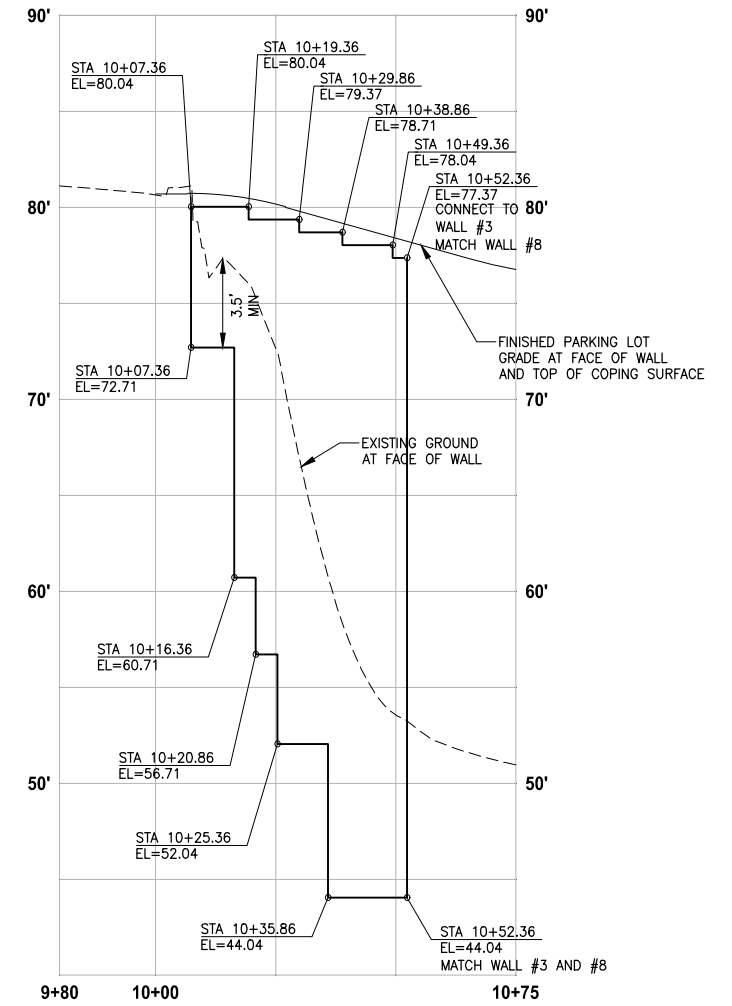

**LEFT STRUCTURAL EARTH WALL  
WALL #7 (FILL) C-LINE**

HORIZ: 1"=20'  
VERT: 1"=5'

**NOTE:**  
1. UTILITIES SHOWN ARE APPROXIMATE. CONTRACTOR TO VERIFY LOCATIONS AND DEPTH, AS AUTHORIZED BY THE ENGINEER.

CITY OF SAMMAMISH APPROVAL	
City Engineer _____	Date _____
Community Development _____	Date _____

**Exhibit 13**  
**NOT FOR CONSTRUCTION**  
**SSDP2016-00414**  
**000191**

LAYOUT: WP2 PATH: U:\PSO\Projects\Clients\1521-KingCo\564-1521-075-ELST\99\Secs\CADD\Phase 21\T03\DWG\ PLOTTED BY: purganbut DATE: Tuesday, October 11, 2016 7:58:25 PM

REVISIONS	DATE	BY	DESIGNED
			J. JUN
			B. PURGANAN
			P. JOHANNESSEN
			Y. HO

ONE INCH AT FULL SCALE.  
IF NOT, SCALE ACCORDINGLY

FILE NAME: BL1521075P21T03WP-01  
JOB No.: 564-1521-075 P21T03  
DATE: OCTOBER 2016

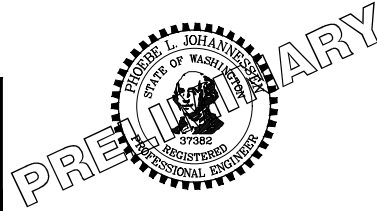

**Parametrix**  
ENGINEERING · PLANNING · ENVIRONMENTAL SCIENCES

719 2ND AVENUE, SUITE 200 | SEATTLE, WA 98104  
P 206.394.3700  
WWW.PARAMETRIX.COM

PROJECT NAME  
**EAST LAKE SAMMAMISH  
MASTER PLAN TRAIL  
INGLEWOOD HILL ROAD PARKING LOT**  
SAMMAMISH, WA

**WALL PROFILES**

SHEET NO.  
16 OF 27  
**WP2**

SEC'S 8, 17 TWP. 24 N., RGE. 06 E, W.M.

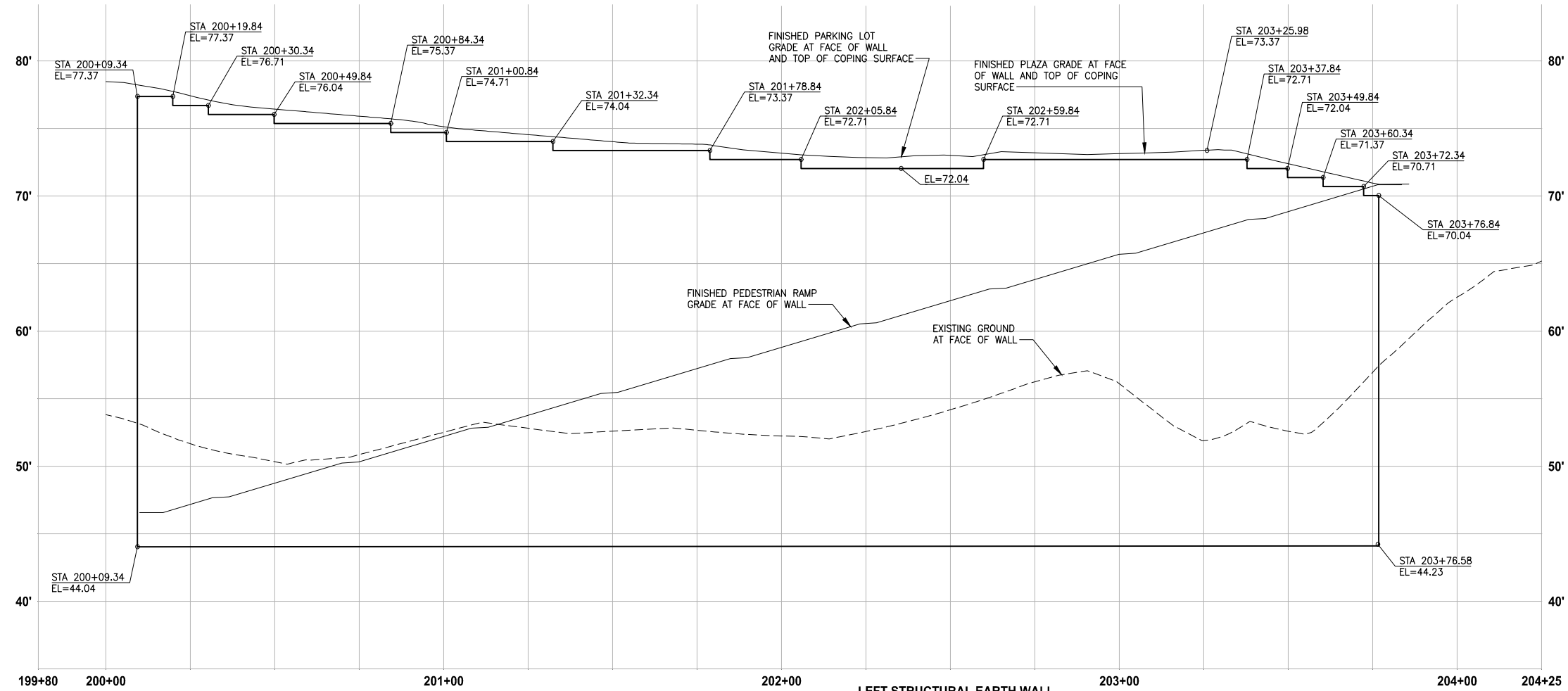

**LEFT STRUCTURAL EARTH WALL  
WALL #8 (FILL) B2-LINE**

HORIZ: 1"=20'  
VERT: 1"=5'

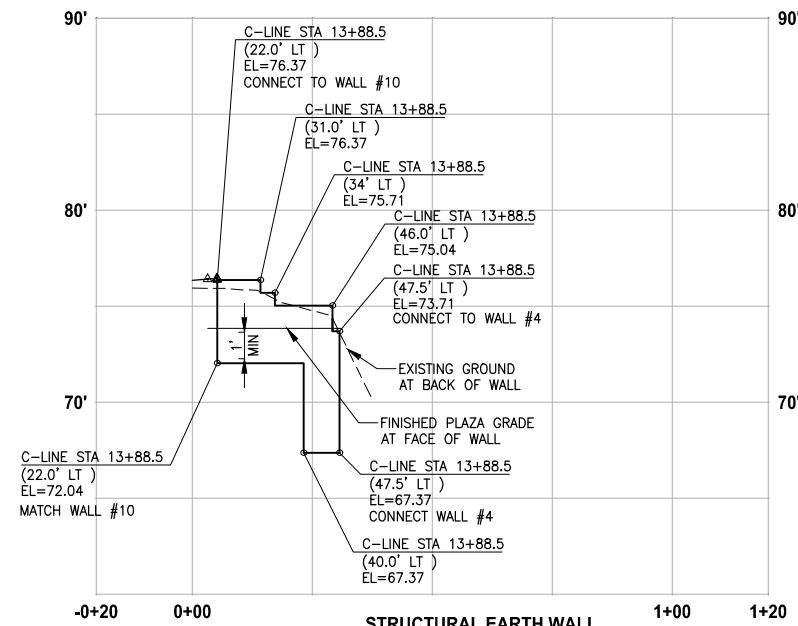

**STRUCTURAL EARTH WALL  
WALL #9 (CUT) C-LINE**

HORIZ: 1"=20'  
VERT: 1"=5'

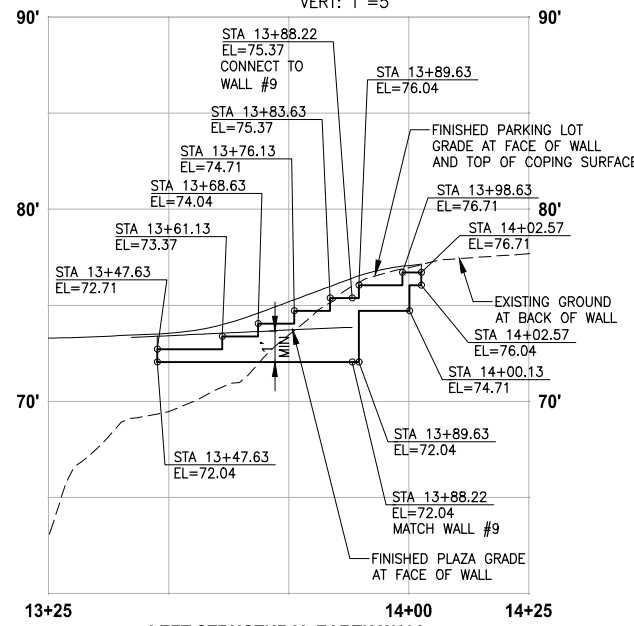

**LEFT STRUCTURAL EARTH WALL  
WALL #10 (FILL) C-LINE**

HORIZ: 1"=20'  
VERT: 1"=5'

**NOTE:**  
1. UTILITIES SHOWN ARE APPROXIMATE. CONTRACTOR TO VERIFY LOCATIONS AND DEPTH, AS AUTHORIZED BY THE ENGINEER.

CITY OF SAMMAMISH APPROVAL	
City Engineer _____	Date _____
Community Development _____	Date _____

**Exhibit 13**  
**NOT FOR CONSTRUCTION**  
**SSDP2016-00414**  
**000192**

LAYOUT: WP3 PATH: U:\PSO\Projects\Clients\1521-KingCo\564-1521-075-ELST\99\Secs\CADD\Phase 2\1\T03\DWG\ PLOTTED BY: purgaban DATE: Tuesday, October 11, 2016 7:58:41 PM

REVISIONS	DATE	BY	DESIGNED
			J. JUN
			B. PURGANAN
			P. JOHANNESSEN
			Y. HO

ONE INCH AT FULL SCALE, IF NOT, SCALE ACCORDINGLY  
FILE NAME: BL1521075P21T03WP-01  
JOB No.: 554-1521-075 P21T03  
DATE: OCTOBER 2016

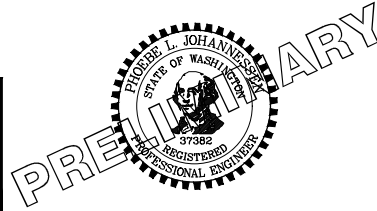

**Parametrix**  
ENGINEERING · PLANNING · ENVIRONMENTAL SCIENCES  
719 2ND AVENUE, SUITE 200 | SEATTLE, WA 98104  
P 206.394.3700  
WWW.PARAMETRIX.COM

PROJECT NAME  
**EAST LAKE SAMMAMISH  
MASTER PLAN TRAIL  
INGLEWOOD HILL ROAD PARKING LOT**  
SAMMAMISH, WA

**WALL PROFILES**

SHEET NO.  
17 OF 27  
**WP3**



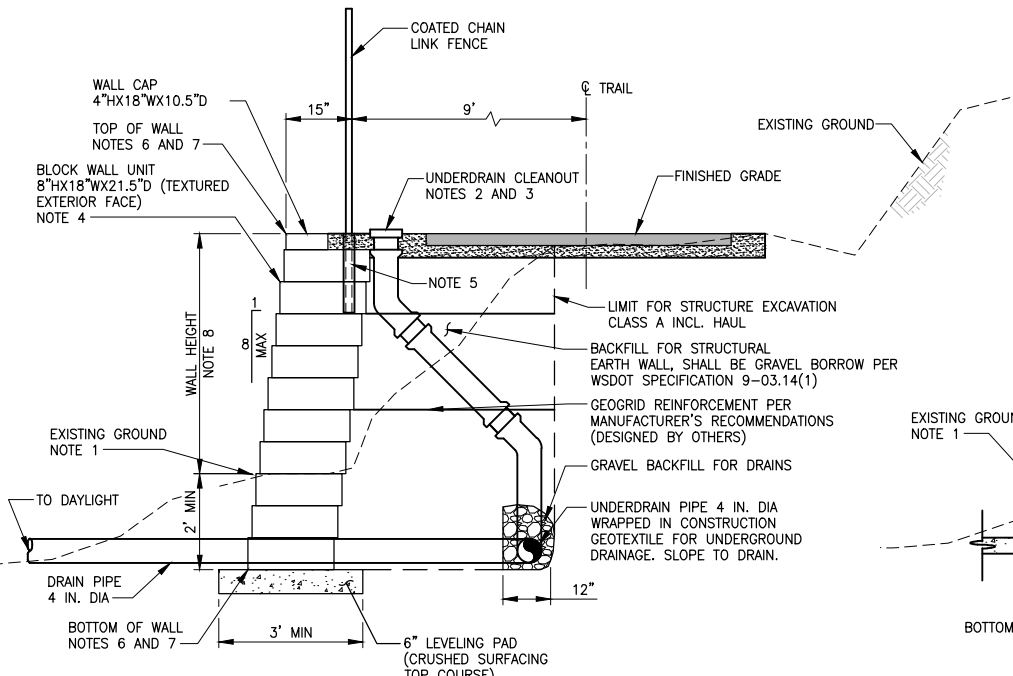

**STRUCTURAL EARTH WALL - FILL WALL  
DETAIL 1**  
NO SCALE

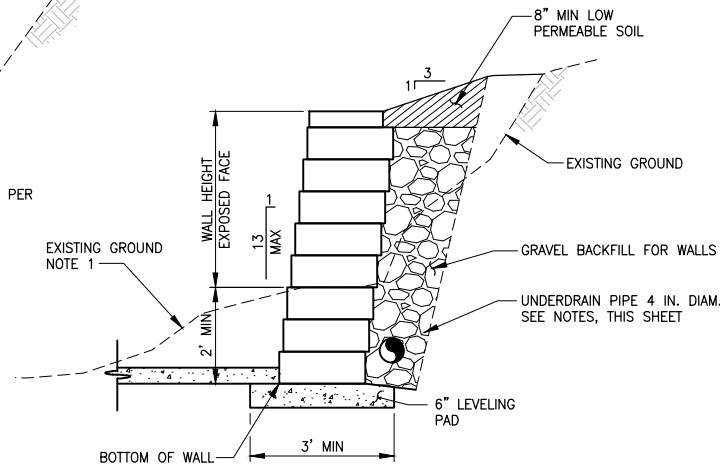

**STRUCTURAL EARTH WALL - CUT WALL  
DETAIL 2**  
NO SCALE

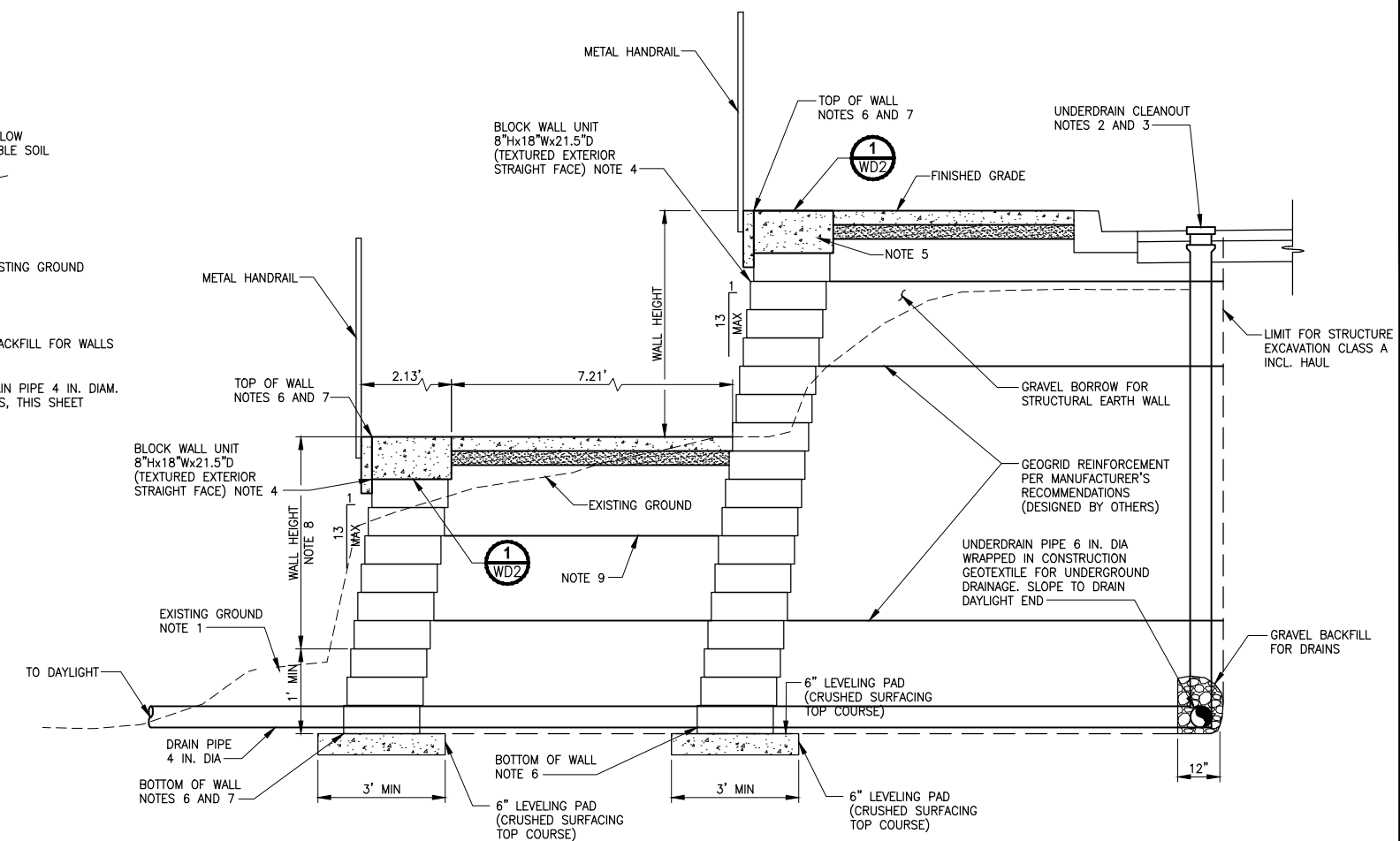

**STRUCTURAL EARTH WALL - FILL WALL  
DETAIL 3**  
NO SCALE

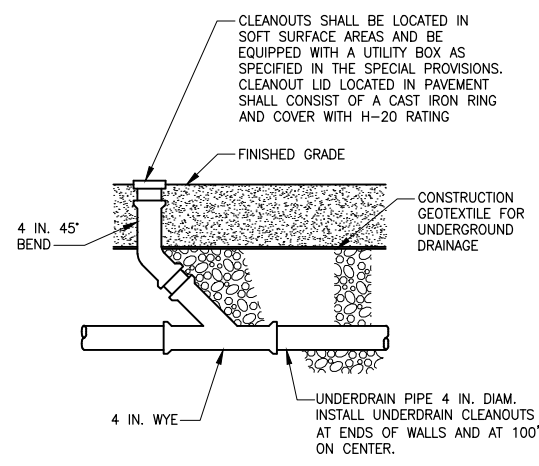

**UNDERDRAIN CLEANOUT  
DETAIL 4**  
NO SCALE

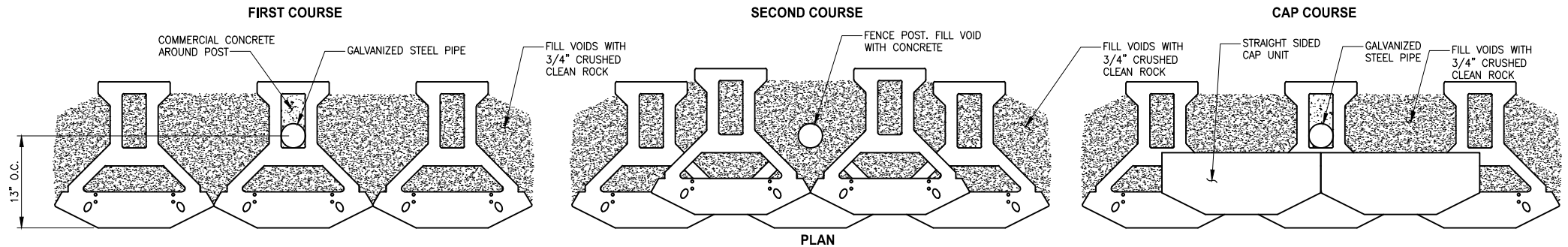

**REAR COURSE POSITIONING  
DETAIL 5**  
NO SCALE

- NOTES:**
- RESTORE EXISTING GROUND WITH NATIVE SOIL BACKFILL AND SEEDING. SEE WP SHEETS.
  - SEE UNDERDRAIN CLEANOUT DETAIL 4 ON THIS SHEET.
  - UNDERDRAIN CLEANOUT LIDS SHALL BE INSTALLED ALONG THE BACK OF WALL BLOCK AND SHALL NOT BE IN TRAIL HMA PAVEMENT.
  - FILL BLOCK UNITS WITH UNIT DRAINAGE FILL. SEE SPECIAL PROVISIONS FOR WALL DESIGN REQUIREMENTS. ALL CONSTRUCTION MUST CONFORM TO MANUFACTURER'S SPECIFIC REQUIREMENTS.
  - POST SHALL HAVE MIN 24" DEPTH. SEE DETAIL 6 ON THIS SHEET.
  - SEE WP SHEETS FOR TOP AND BOTTOM OF WALL ELEVATIONS.
  - SEE OFFSET DISTANCE ON SHEET WPX FOR OUTSIDE FACE OF CAP BLOCK. BOTTOM OF WALL OFFSET DISTANCE SHALL BE SURVEYED AND STAKED BASED ON WALL HEIGHT SHOWN ON WP SHEETS AND WALL BATTER AS SHOWN IN DETAILS 1, 2 AND 3 ON THIS SHEET.
  - SEE WALL SCHEDULE ON SHEET WPX.
  - ANCHOR GEOGRID REINFORCEMENT BETWEEN BLOCKS PER MANUFACTURER'S REQUIREMENTS.

**DESIGN LOAD FOR FILL WALLS**

LIVELOAD FOR TRAIL	100 PSF
LIVELOAD FOR DRIVEWAY	250 PSF
DEADLOAD	NONE

**CITY OF SAMMAMISH APPROVAL**

City Engineer	Date
Community Development	Date

**Exhibit 13**  
**NOT FOR CONSTRUCTION**  
**SSDP2016-00414**  
**000193**

LAYOUT: WD1  
 PATH: U:\PSO\Projects\Clients\1521-KingCo\1521-075-ELST\99\Secs\CADD\Phase 21\T03\DWG\...  
 PLOTTED BY: purganbut DATE: Tuesday, October 11, 2016 7:59:12 PM

REVISIONS	DATE	BY	DESIGNED
			J. JUN
			B. PURGANAN
			P. JOHANNESSEN
			Y. HO

**ONE INCH AT FULL SCALE, IF NOT, SCALE ACCORDINGLY**

FILE NAME: BL1521075P21T03WD-01  
 JOB No.: 54-1521-075 P21T03  
 DATE: OCTOBER 2016

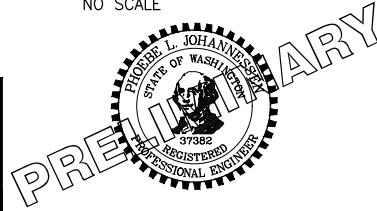

**Parametrix**  
 ENGINEERING · PLANNING · ENVIRONMENTAL SCIENCES

719 2ND AVENUE, SUITE 200 | SEATTLE, WA 98104  
 P 206.394.3700  
 WWW.PARAMETRIX.COM

PROJECT NAME  
**EAST LAKE SAMMAMISH  
 MASTER PLAN TRAIL  
 INGLEWOOD HILL ROAD PARKING LOT**  
 SAMMAMISH, WA

**STRUCTURAL EARTH  
 WALL DETAILS**

SHEET NO.  
 18 OF 27  
**WD1**

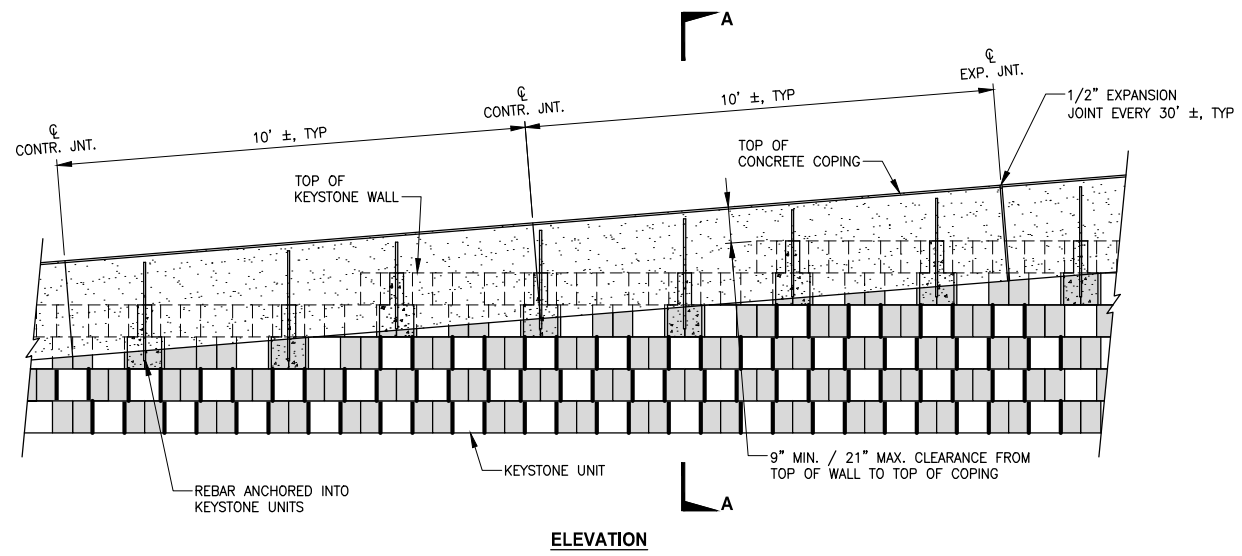

ELEVATION

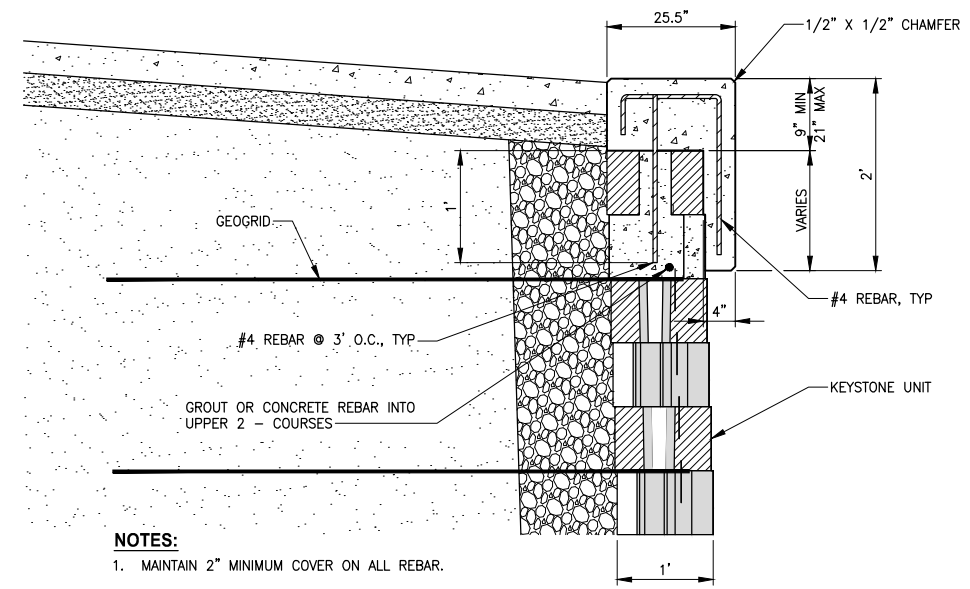

SECTION A-A

- NOTES:**
1. MAINTAIN 2" MINIMUM COVER ON ALL REBAR.
  2. FULL EXPANSION JOINTS SHALL BE PLACED EVERY 3RD JOINT AND AT ALL WALL RADIUS AND BEND POINTS.
  3. INSURE THAT ALL TOP OF WALL STEPS ARE COMPLETELY COVERED BY OVERHANG OF CONCRETE COPING (3" MIN).

**PARTIAL C.I.P CONCRETE COPING  
DETAIL**

NO SCALE

LAYOUT: WP2  
 PATH: U:\PSO\Projects\Clients\1521-KingCo\564-1521-075-ELST\99Sves\CADD\Phase 21\T03\DWG\  
 PLOTTED BY: purgobut DATE: Tuesday, October 11, 2016 7:59:28 PM

REVISIONS	DATE	BY	DESIGNED
			J. JUN
			B. PURGANAN
			P. JOHANNESSEN
			Y. HO

**ONE INCH AT FULL SCALE,  
IF NOT, SCALE ACCORDINGLY**  
 FILE NAME: BL1521075P21T03WD-01  
 JOB No.: 564-1521-075 P21T03  
 DATE: OCTOBER 2016

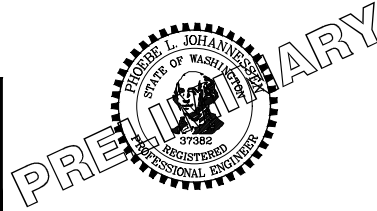

**Parametrix**  
 ENGINEERING · PLANNING · ENVIRONMENTAL SCIENCES  
 719 2ND AVENUE, SUITE 200 | SEATTLE, WA 98104  
 P 206.394.3700  
 WWW.PARAMETRIX.COM

PROJECT NAME  
**EAST LAKE SAMMAMISH  
MASTER PLAN TRAIL  
INGLEWOOD HILL ROAD PARKING LOT**  
 SAMMAMISH, WA

**STRUCTURAL EARTH  
WALL DETAILS**

SHEET NO.  
 19 OF 27  
**WD2**

CITY OF SAMMAMISH APPROVAL	
City Engineer _____	Date _____
Community Development _____	Date _____

Exhibit 13  
 NOT FOR CONSTRUCTION  
**SSDP2016-00414**  
**000194**



# TO BE ADDED

PATH: U:\P50\Projects\Clients\1521-KingCo\554-1521-075-ELST\98\Secs\CADD\Phase 21\T03\DWG\ PLOTTED BY: purgabut DATE: Tuesday, October 11, 2016 8:00:06 PM  
 LAYOUT: RD1

REVISIONS	DATE	BY	DESIGNED
			J. JUN
			DRAWN
			B. PURGANAN
			CHECKED
			P. JOHANNESSEN
			APPROVED
			Y. HO

**ONE INCH AT FULL SCALE.  
 IF NOT, SCALE ACCORDINGLY**  
 FILE NAME  
 BL1521075P21T03RD-01  
 JOB No.  
 554-1521-075 P21T03  
 DATE  
 OCTOBER 2016

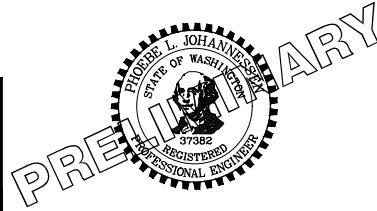

**Parametrix**  
 ENGINEERING · PLANNING · ENVIRONMENTAL SCIENCES  
 719 2ND AVENUE, SUITE 200 | SEATTLE, WA 98104  
 P 206.394.3700  
 WWW.PARAMETRIX.COM

PROJECT NAME  
**EAST LAKE SAMMAMISH  
 MASTER PLAN TRAIL  
 INGLEWOOD HILL ROAD PARKING LOT**  
 SAMMAMISH, WA

**RESTROOM FACILITY DETAIL**

SHEET NO.  
 20 OF 27  
**RD1**

CITY OF SAMMAMISH APPROVAL	
City Engineer _____	Date _____
Community Development _____	Date _____

**Exhibit 13**  
 NOT FOR CONSTRUCTION  
**SSDP2016-00414**  
**000195**

SEC'S 8, 17 TWP. 24 N., RGE. 06 E, W.M.

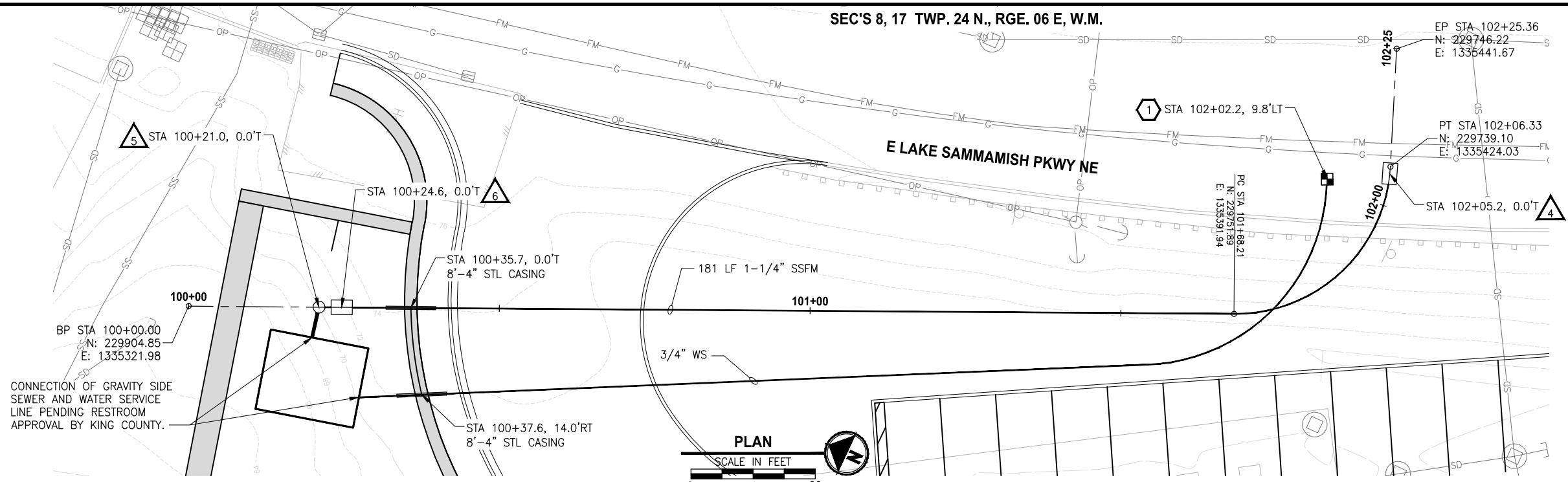

- SEWER NOTES:**
1. PRESSURE PIPE AND FITTINGS SHALL BE 1-1/4" HDPE (SDR 11) PER SPSWD SIDE SEWER REGULATIONS ARTICLE VIII.
  2. ALL HDPE WELDING SHALL BE MADE USING ELECTRO-FUSION.
  3. GRAVITY PIPE AND FITTINGS SHALL BE 6" PVC (C900) PER SPSWD SIDE SEWER REGULATIONS ARTICLE VII.
4. EXISTING COLLECTION VALVE BOX WITH UNION BALL VALVE AND SWING CHECK VALVE. CONNECT TO UNION BALL VALVE PER SPSWD SIDE SEWER REGULATIONS COLLECTION VALVE BOX DETAIL.
5. GRINDER SEWER PUMP SYSTEM PER SPSWD SIDE SEWER REGULATIONS SECTION 8.10 AND 8.11, GRINDER PUMP INSTALLATION DETAIL AND GRINDER PUMP SITE LAYOUT INSTRUCTIONS.
6. GRINDER PUMP CLEANOUT PER SPSWD SIDE SEWER REGULATIONS SECTION 8.09 AND GRINDER PUMP CLEANOUT DETAIL.

- WATER NOTES:**
1. CONNECT TO EXISTING 3/4" WATER METER SETTER PER SPSWD 3/4" AND 1" METER SETTER DETAIL. NEW METER SHALL BE PURCHASED FROM THE DISTRICT. THE DISTRICT SHALL INSTALL THE METER AT THE TIME OF FINAL ACCEPTANCE.

- ELECTRICAL NOTES:**
1. ELECTRICAL DESIGN TO BE SUBMITTED WITH 90% DESIGN SUBMITTAL, PENDING KING COUNTY APPROVAL OF RESTROOM FACILITY.

- GENERAL NOTES:**
1. EXISTING UTILITY LOCATIONS ARE APPROXIMATE. CONTRACTOR SHALL FIELD VERIFY PRIOR TO CONSTRUCTION OF THE WATER AND SEWER SERVICE LINES.

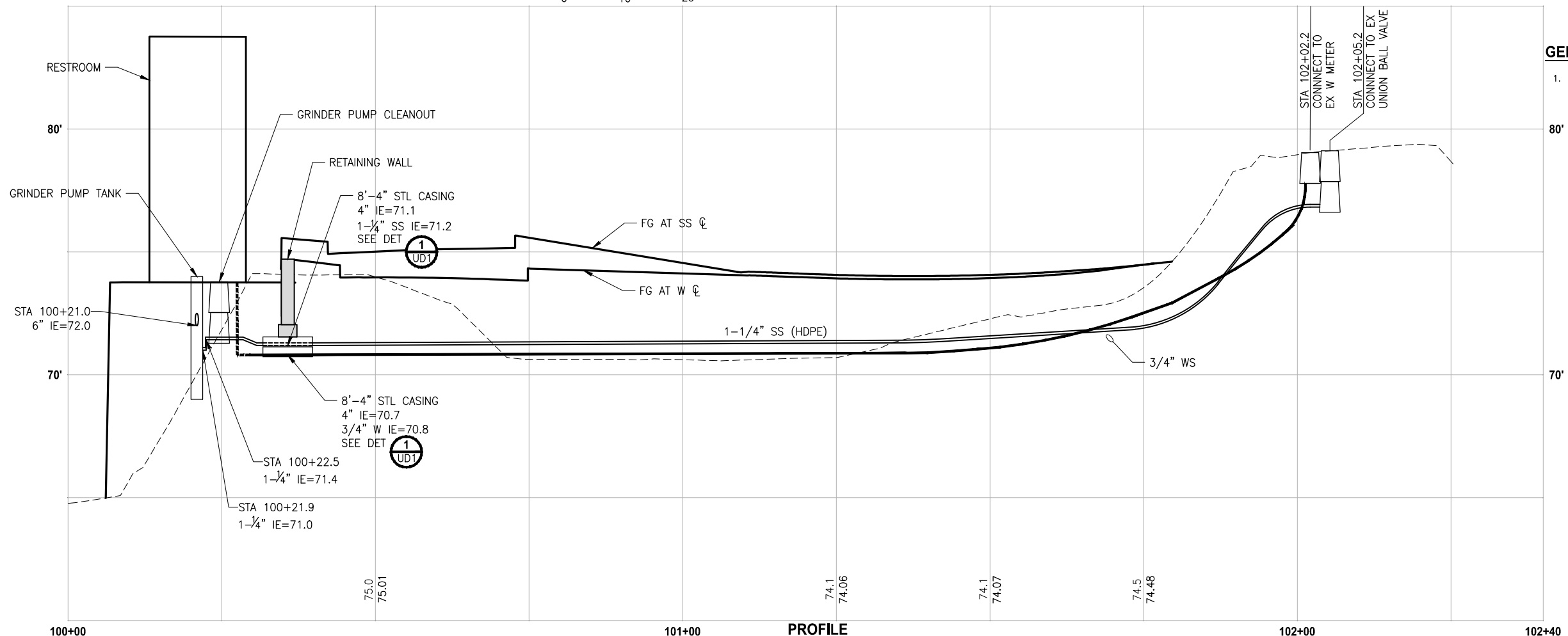

**PROFILE**  
 HORIZ: 1"=10'  
 VERT: 1"=2.5'

CITY OF SAMMAMISH APPROVAL	
City Engineer _____	Date _____
Community Development _____	Date _____

**Exhibit 13**  
 NOT FOR CONSTRUCTION  
**SSDP2016-00414**  
**000196**

PATH: U:\P50\Projects\Clients\1521-KingCo\554-1521-075-ELST\99Secs\CADD\Phase 21\103\DWG\ PLOTTED BY: purgabut DATE: Tuesday, October 11, 2016 8:02:27 PM LAYOUT: UP1

REVISIONS	DATE	BY	DESIGNED
			M. MILLER
			M. MILLER
			P. JOHANNESSEN
			Y. HO

**ONE INCH AT FULL SCALE, IF NOT, SCALE ACCORDINGLY**

FILE NAME: BL1521075P21T03UP-01  
 JOB No: 554-1521-075 P21T03  
 DATE: OCTOBER 2016

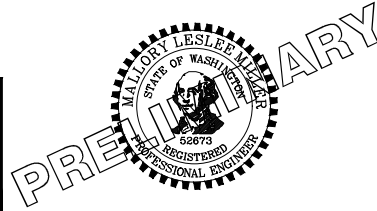

**Parametrix**  
 ENGINEERING · PLANNING · ENVIRONMENTAL SCIENCES

719 2ND AVENUE, SUITE 200 | SEATTLE, WA 98104  
 P 206.394.3700  
 WWW.PARAMETRIX.COM

PROJECT NAME  
**EAST LAKE SAMMAMISH MASTER PLAN TRAIL INGLEWOOD HILL ROAD PARKING LOT**  
 SAMMAMISH, WA

**UTILITY AND ELECTRICAL PLAN**

SHEET NO.  
 21 OF 27  
**UP1**

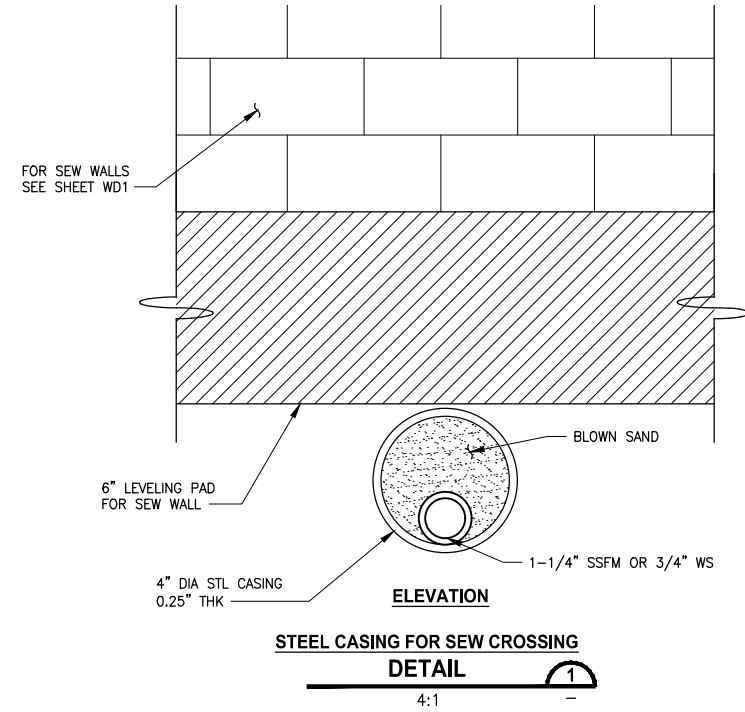

PATH: U:\PSO\Projects\Clients\1521-KingCo\554-1521-075-ELST\99Secs\CADD\Phase 21\T03\DWG\ PLOTTED BY: purgabut DATE: Tuesday, October 11, 2016 8:02:59 PM  
 LAYOUT: UD1

REVISIONS	DATE	BY	DESIGNED
			J. JUN
			DRAWN B. PURGANAN
			CHECKED P. JOHANNESSEN
			APPROVED Y. HO

**ONE INCH AT FULL SCALE.  
 IF NOT, SCALE ACCORDINGLY**  
 FILE NAME  
 BL1521075P21T03UD-01  
 JOB No.  
 554-1521-075 P21T03  
 DATE  
 OCTOBER 2016

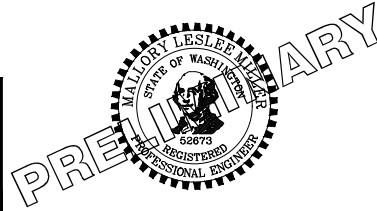

**Parametrix**  
 ENGINEERING · PLANNING · ENVIRONMENTAL SCIENCES  
 719 2ND AVENUE, SUITE 200 | SEATTLE, WA 98104  
 P 206.394.3700  
 WWW.PARAMETRIX.COM

PROJECT NAME  
**EAST LAKE SAMMAMISH  
 MASTER PLAN TRAIL  
 INGLEWOOD HILL ROAD PARKING LOT**  
 SAMMAMISH, WA

**UTILITY AND ELECTRICAL DETAILS**

SHEET NO.  
 22 OF 27  
**UD1**

CITY OF SAMMAMISH APPROVAL	
City Engineer _____	Date _____
Community Development _____	Date _____

**Exhibit 13**  
 NOT FOR CONSTRUCTION  
**SSDP2016-00414**  
**000197**

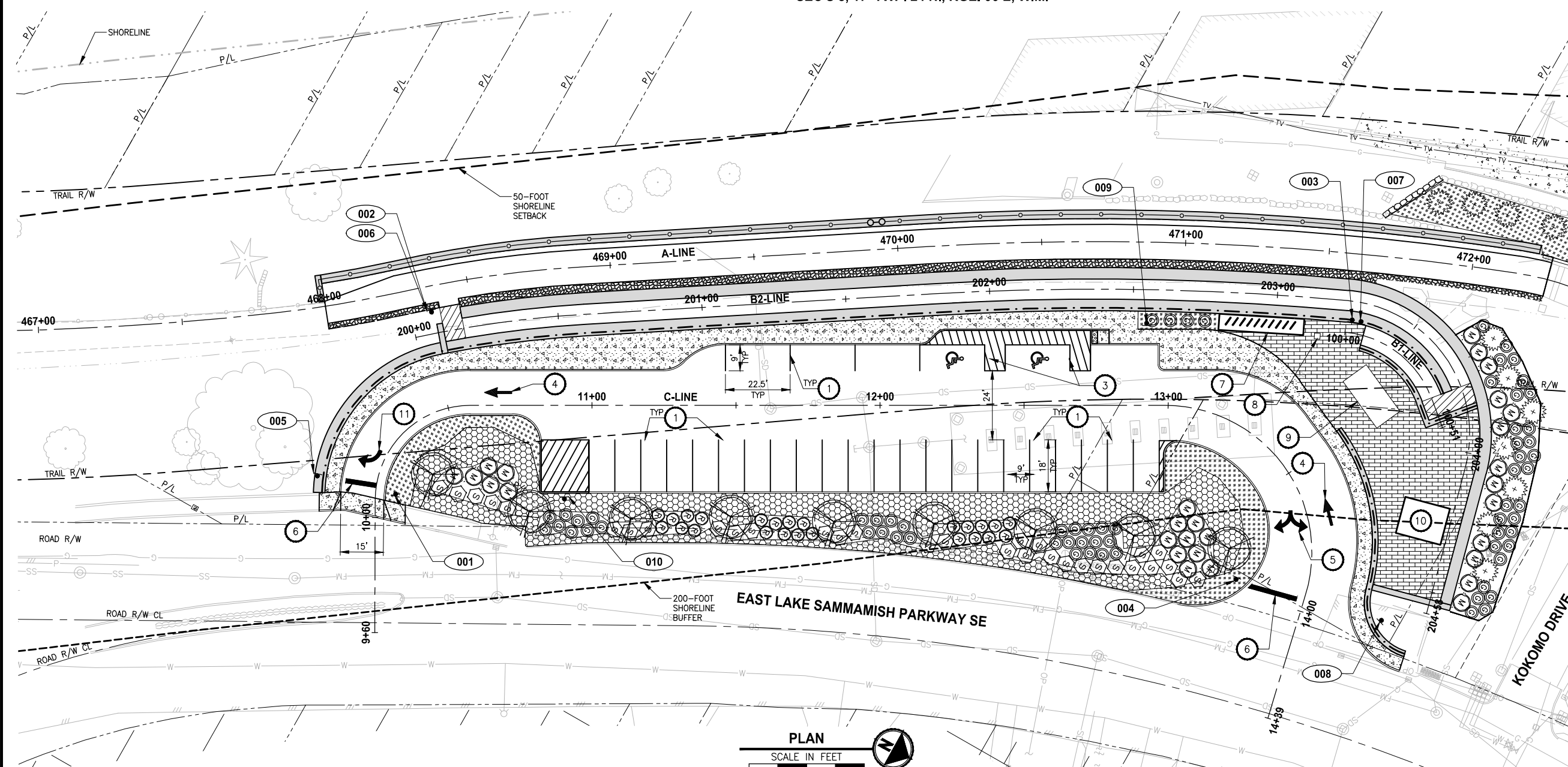

**PAVEMENT MARKING AND SIGNING CONSTRUCTION NOTES:**

- 1 WHITE PAINT LINE PER WSDOT STD PLAN M-17.10-02.
- 2 YELLOW PAINT LINE PER WSDO STD PLAN M-17.10-02.
- 3 PLASTIC ACCESS PARKING SPACE SYMBOL STANDARD PER WSDOT STD PLAN M-24.60-04.
- 4 PLASTIC TRAFFIC ARROW TYPE 1S PER WSDOT STD PLAN M-24.40-02.
- 5 PLASTIC TRAFFIC ARROW TYPE 4S PER WSDOT STD PLAN M-24.40-02.
- 6 STOP LINE PER WSDOT STD PLAN M-24.60-04.
- 7 SHELTERED BIKE PARKING.
- 8 KIOSK CONCRETE PAD.
- 9 SHELTER.
- 10 RESTROOM.
- 11 PLASTIC TRAFFIC ARROW TYPE 2SR PER WSDOT STD PLAN M-24.40-02.

**LEGEND:**

- X SIGN, SEE SIGN SCHEDULE ON THIS SHEET.

**PLANT LEGEND:**

- M WAX MYRTLE SHRUB
- G TALL OREGON GRAPE SHRUB
- S SNOWBERRY SHRUB
- \* WESTERN RED CEDAR TREE
- PM PARKWAY MAPLE
- LOW GROW PLANTING MIX, SEE SHEET LD1 FOR INFORMATION.
- NATIVE ROSE SHRUB PLANTING, SEE SHEET LD1 FOR INFORMATION.

**NOTE:**

1. SEE PLANT LISTS AND DETAILS ON SHEET LD1.

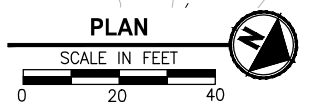

**SIGN SCHEDULE**

SIGN NUMBER	LOCATION			DESCRIPTION	MUTCD SIGN	SIGN SIZE	POST SIZE/TYPE	REMARK
	ALIGNMENT	STATION	OFFSET					
001	C-LINE	10+09	7.0' RT	DO NOT ENTER	R5-1	36" X 36"	2.5" X 2.5" 12-GAGE STEEL TUBE	NEW SIGN AND POST
002	A-LINE	468+36	9.0' RT	BICYCLES DISMOUNT	CUSTOM	12" X 18"	2.5" X 2.5" 12-GAGE STEEL TUBE	NEW SIGN AND POST
003	C-LINE	13+33	52.6' LT	BICYCLES DISMOUNT	CUSTOM	12" X 18"	N/A	NEW SIGN MOUNTED ON HANDRAIL
004	C-LINE	13+96	24.6' RT	STOP	R1-1	30" X 30"	2.5" X 2.5" 12-GAGE STEEL TUBE	NEW SIGN AND POST
005	C-LINE	10+13	21.0' LT	NO LEFT TURN SYMBOL	R3-2	24" X 24"	2.5" X 2.5" 12-GAGE STEEL TUBE	NEW SIGN AND POST
006	A-LINE	468+36	9.0' RT	WALK BICYCLE UP RAMP	CUSTOM	12" X 18"	2.5" X 2.5" 12-GAGE STEEL TUBE	NEW SIGN ON SAME POST AS SIGN #2
007	C-LINE	13+35	54.1' LT	WALK BICYCLE DOWN RAMP	CUSTOM	12" X 18"	N/A	NEW SIGN MOUNTED ON HANDRAIL
008	C-LINE	13+95	27.8' LT	PARKING LOT CLOSED DUSK TO DAWN	R7-2 MOD	12" X 18"	2.5" X 2.5" 12-GAGE STEEL TUBE	NEW SIGN AND POST
009	C-LINE	12+92	28.5' LT	PARKING LOT CLOSED DUSK TO DAWN	R7-2 MOD	12" X 18"	2.5" X 2.5" 12-GAGE STEEL TUBE	NEW SIGN AND POST
010	C-LINE	10+40	32.5' RT	NO PARKING TURN AROUND ZONE	R7-1 MOD	12" X 18"	2.5" X 2.5" 12-GAGE STEEL TUBE	NEW SIGN AND POST

STATE OF WASHINGTON  
LICENSED  
LANDSCAPE ARCHITECT

JENS SWENSON  
LICENSE NO. 656  
EXPIRES ON \_\_\_\_\_

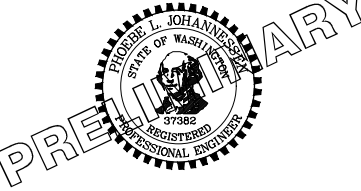

CITY OF SAMMAMISH APPROVAL

City Engineer _____	Date _____
Community Development _____	Date _____

**Exhibit 13**  
**SSDP2016-00414**

REVISIONS	DATE	BY	DESIGNED
			J. JUN / J. SWENSON
			B. PURGANAN
			P. JOHANNESSEN
			Y. HO

ONE INCH AT FULL SCALE, IF NOT, SCALE ACCORDINGLY

FILE NAME: BL1521075P21T03PS-01  
JOB No.: 554-1521-075 P21T03  
DATE: OCTOBER 2016

**Parametrix**  
ENGINEERING · PLANNING · ENVIRONMENTAL SCIENCES

719 2ND AVENUE, SUITE 200 | SEATTLE, WA 98104  
P 206.394.3700  
WWW.PARAMETRIX.COM

PROJECT NAME  
**EAST LAKE SAMMAMISH MASTER PLAN TRAIL INGLEWOOD HILL ROAD PARKING LOT**  
SAMMAMISH, WA

**PAVEMENT MARKING, SIGNING, AND LANDSCAPE PLAN**

SHEET NO.  
23 OF 27

**PS1**

PATH: U:\PSO\Projects\Clients\1521-075-ELST\985\Secs\CA00\Phase 21\T03\DWG\ PLOTTED BY: purganab DATE: Wednesday, October 12, 2016 1:22:05 PM LAYOUT: PSI

MATCHLINE SEE SHEET PS2



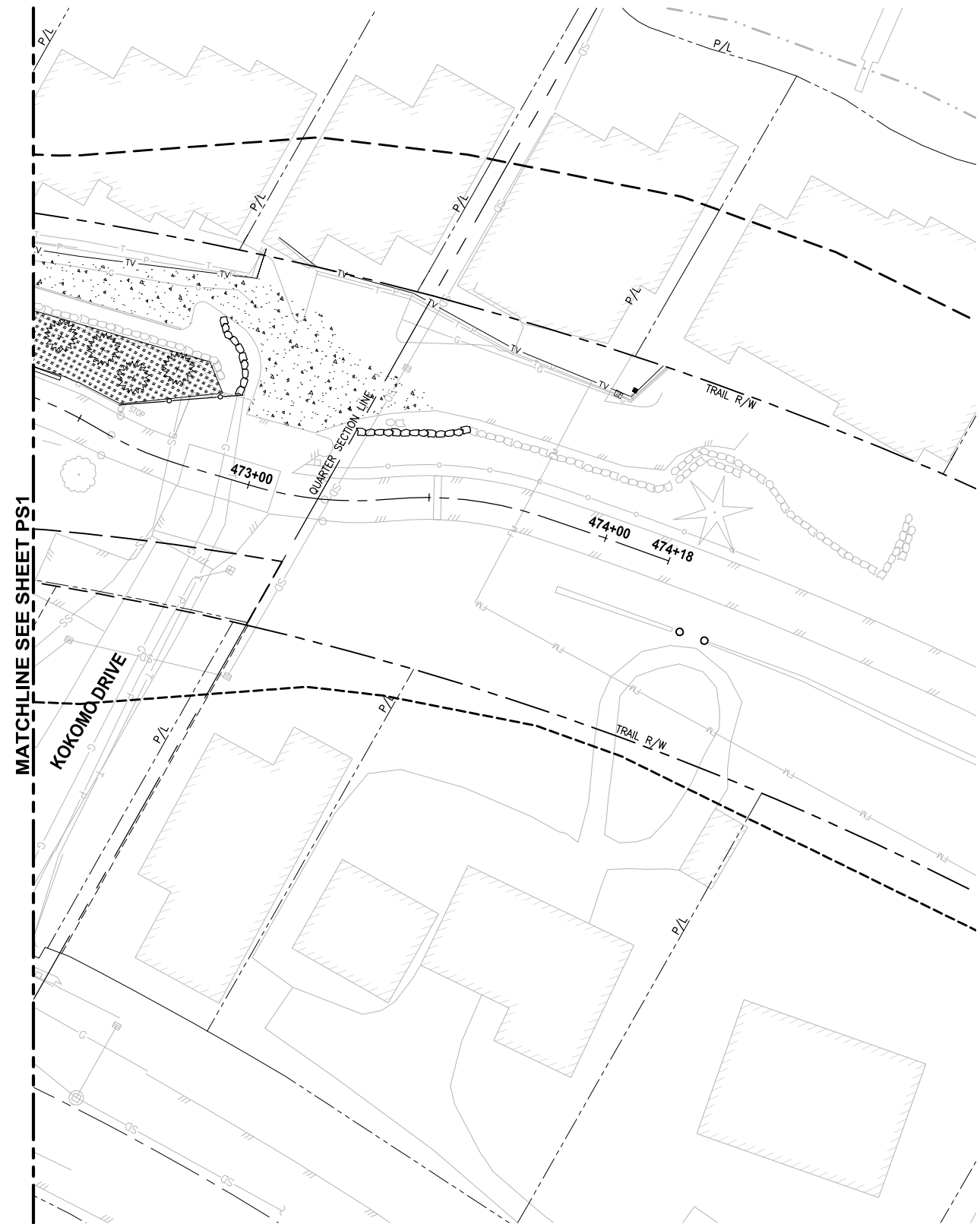

**PAVEMENT MARKING AND SIGNING CONSTRUCTION NOTES:**

- 1 WHITE PAINT LINE PER WSDOT STD PLAN M-17.10-02.
- 2 YELLOW PAINT LINE PER WSDO STD PLAN M-17.10-02.
- 3 PLASTIC ACCESS PARKING SPACE SYMBOL STANDARD PER WSDOT STD PLAN M-24.60-04.
- 4 PLASTIC TRAFFIC ARROW TYPE 1S PER WSDOT STD PLAN M-24.40-02.
- 5 PLASTIC TRAFFIC ARROW TYPE 4S PER WSDOT STD PLAN M-24.40-02.
- 6 STOP LINE PER WSDOT STD PLAN M-24.60-04.
- 7 SHELTERED BIKE PARKING.
- 8 KIOSK CONCRETE PAD.
- 9 SHELTER.
- 10 RESTROOM.
- 11 PLASTIC TRAFFIC ARROW TYPE 2SR PER WSDOT STD PLAN M-24.40-02.

**LEGEND:**

- X SIGN, SEE SIGN SCHEDULE ON THIS SHEET.

**PLANT LEGEND:**

- M WAX MYRTLE SHRUB
- G TALL OREGON GRAPE SHRUB
- S SNOWBERRY SHRUB
- + WESTERN RED CEDAR TREE
- PM PARKWAY MAPLE
- LOW GROW PLANTING MIX, SEE SHEET LD1 FOR INFORMATION.
- NATIVE ROSE SHRUB PLANTING, SEE SHEET LD1 FOR INFORMATION.

**NOTE:**

1. SEE PLANT LISTS AND DETAILS ON SHEET LD1.

MATCHLINE SEE SHEET PS1

STATE OF WASHINGTON  
LICENSED LANDSCAPE ARCHITECT  
  
JENS SWENSON  
LICENSE NO. 656  
EXPIRES ON \_\_\_\_\_



CITY OF SAMMAMISH APPROVAL	
City Engineer _____	Date _____
Community Development _____	Date _____

**Exhibit 13**  
**NOT FOR CONSTRUCTION**  
**SSDP2016-00414**  
**000199**

LAYOUT: PS2 PATH: U:\PSO\Projects\Clients\1521-KingCo\554-1521-075-ELST\99\Ses\CAD00\Phase 21\T03\DWG\ PLOTTED BY: purgabul DATE: Wednesday, October 12, 2016 1:22:15 PM

REVISIONS	DATE	BY	DESIGNED
			J. JUN / J. SWENSON
			B. PURGANAN
			P. JOHANNESSEN
			Y. HO

**ONE INCH AT FULL SCALE. IF NOT, SCALE ACCORDINGLY**  
FILE NAME: BL1521075P21T03PS-01  
JOB No.: 554-1521-075 P21T03  
DATE: OCTOBER 2016

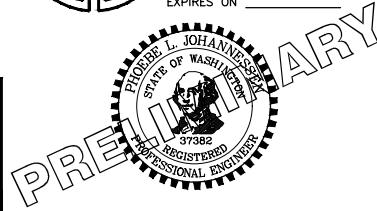

**Parametrix**  
ENGINEERING · PLANNING · ENVIRONMENTAL SCIENCES  
719 2ND AVENUE, SUITE 200 | SEATTLE, WA 98104  
P 206.394.3700  
WWW.PARAMETRIX.COM

PROJECT NAME  
**EAST LAKE SAMMAMISH MASTER PLAN TRAIL INGLEWOOD HILL ROAD PARKING LOT**  
SAMMAMISH, WA

**PAVEMENT MARKING, SIGNING, AND LANDSCAPE PLAN**

SHEET NO.  
24 OF 27  
**PS2**

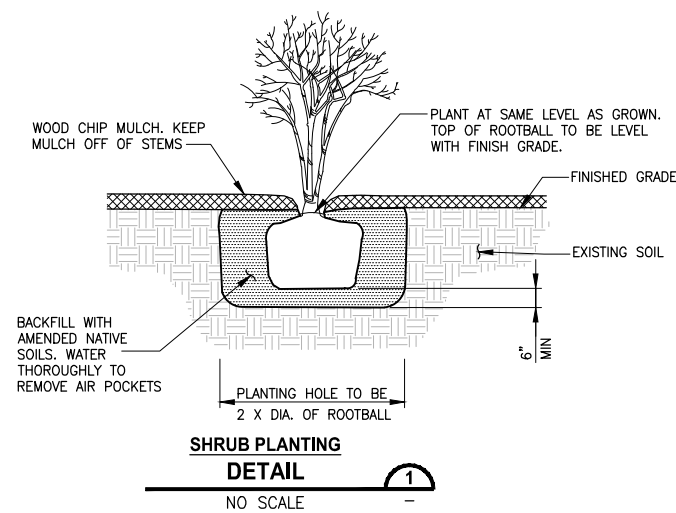

**SHRUB PLANTING DETAIL**  
NO SCALE

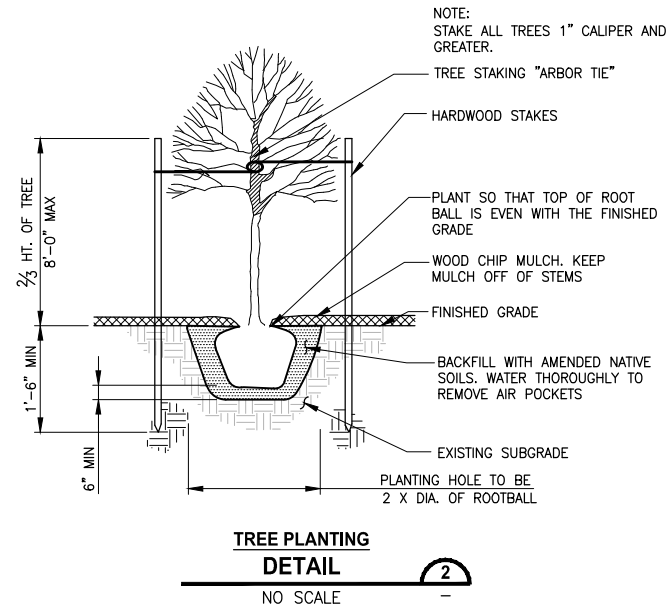

**TREE PLANTING DETAIL**  
NO SCALE

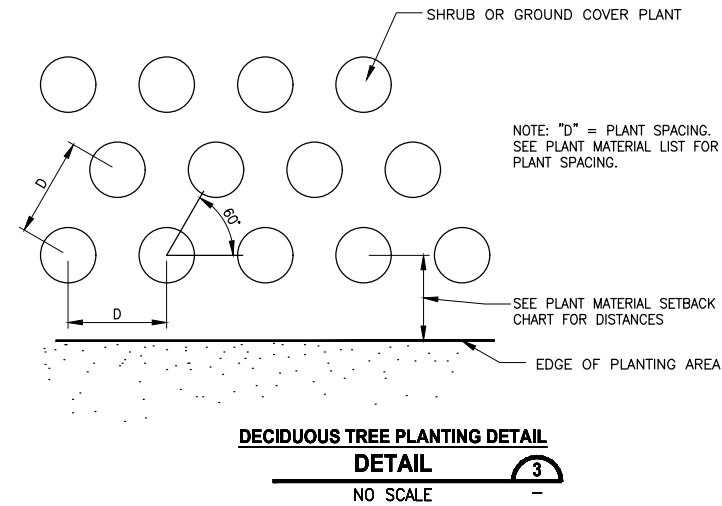

**DECIDUOUS TREE PLANTING DETAIL**  
NO SCALE

**PLANTING NOTES:**

- CONTRACTOR SHALL ARRANGE TO MEET ON SITE WITH THE PROJECT REPRESENTATIVE TO DISCUSS LIMITS OF WORK AND METHODS. CONSTRUCTION ACTIVITIES SHALL NOT COMMENCE UNTIL ACCESS, LIMITS OF WORK, AND METHODS ARE APPROVED. ALL SAFETY FENCING AND TESC MEASURES MUST BE INSTALLED PRIOR TO COMMENCING CONSTRUCTION ACTIVITIES.
- ALL PLANTS TO BE SAVED AND PROTECTED WITHIN PLANTING AREAS WILL BE FLAGGED BY ENGINEER. NOTIFY ENGINEER 5 DAYS PRIOR TO START OF CLEARING ACTIVITY.
- MITIGATION PLANTING PLANS REPRESENT A CONCEPTUAL PLANT LAYOUT. FINAL PLANT LOCATIONS SHALL BE APPROVED BY PROJECT REPRESENTATIVE PRIOR TO PLANTING. COORDINATE DATA WILL BE PROVIDED ELECTRONICALLY FOR LOCATION OF PLANTING AREA BOUNDARIES.
- ALL PLANTS SHALL BE NURSERY GROWN A MINIMUM OF ONE YEAR. PLANT MATERIAL IS TO BE SUPPLIED BY COMMERCIAL NURSERIES. PLANT SUBSTITUTIONS ARE SUBJECT TO APPROVAL BY PROJECT REPRESENTATIVE.
- THE CONTRACTOR SHALL BE RESPONSIBLE FOR DISPOSING OF ALL DEBRIS AND EXCESS SOIL OCCASIONED BY THIS PROJECT.
- CONTRACTOR SHALL VERIFY THE LOCATION OF ALL UTILITIES PRIOR TO EXCAVATION.
- ALL DIMENSIONS FOR LISTED HEIGHT, LENGTH AND CONTAINER SIZE ARE MINIMUM REQUIREMENTS.
- EXISTING AREAS DISTURBED BY CONSTRUCTION ACTIVITIES AND NOT SHOWN TO BE RE-VEGETATED ON THESE PLANS SHALL BE RESTORED AND SEED.
- DISCREPANCIES BETWEEN THE PLANS AND SITE CONDITIONS SHALL BE BROUGHT TO THE ATTENTION OF THE PROJECT REPRESENTATIVE PRIOR TO PROCEEDING WITH EFFECTED WORK.
- SEE SP SHEETS FOR TEMPORARY EROSION CONTROL MEASURES.
- CONTRACTOR SHALL BE RESPONSIBLE FOR WATERING PLANTS FOR THE FIRST YEAR AFTER ACCEPTANCE OF COMPLETION OF PLANTING FOR THE PROJECT. COUNTY WILL MAKE PROVISIONS FOR WATERING AS NEEDED FOR THE REMAINDER OF THE ESTABLISHMENT PERIOD AFTER THE FIRST YEAR.
- CONTRACTOR SHALL REMOVE ALL TREE STAKES AT THE END OF 1 YEAR.

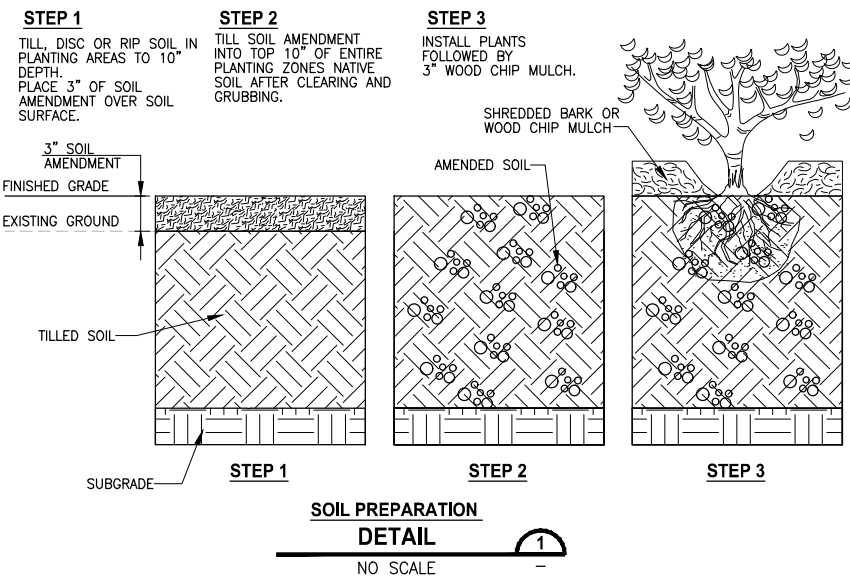

**SOIL PREPARATION DETAIL**  
NO SCALE

**PLANT MATERIAL LIST**

QUANTITY	BOTANICAL NAME	COMMON NAME	MIN SIZE/CONDITION	NOTES/SPACING
<b>TREES</b>				
9	ACER PLATANOIDES 'COLUMNARBROAD'	PARKWAY MAPLE	1 1/2' CAL.	AS SHOWN ON PLAN
15	THUJA PLICATA	WESTERN RED CEDAR	6' TALL	AS SHOWN ON PLAN
<b>SHRUBS</b>				
29	MYRICA CALIFORNICA	PACIFIC WAX MYRTLE	36" HT/ #5 CONT	SPACE 6' O.C.
65	MAHONIA AQUIFOLIUM	TALL OREGON GRAPE	36" HT/ #5 CONT	SPACE 5' O.C.
29	RIBES SANGUINEUM	FLOWERING RED CURRANT	36" HT/ #5 CONT	SPACE 5' O.C.
211	ROSA WOODSII	WOODS ROSE	18" HT/ #2 CONT	SPACE 4' O.C.
32	SYMPHORICARPOS ALBUS	COMMON SNOWBERRY	36" HT/ #5 CONT	SPACE 5' O.C.
<b>LOW SHRUBS AND GROUND COVER</b>				
72	GAULTHERIA SHALLON	SALAL	#1 CONT	SPACE 3' O.C.
72	MAHONIA REPENS	CREEPING OREGON GRAPE	#1 CONT	SPACE 3' O.C.
72	HEREROCALLIS FULVA	DAYLILLY	#1 CONT	SPACE 3' O.C.

**PLANT MATERIAL SETBACK CHART**

	GUARDRAIL BARRIER	EDGE OF ROADWAY	PATHS, TRAILS	WALL	FENCE	SIGNS	EXISTING TREE, TRUNK	EXISTING VEGETATION MASS
EVERGREEN TREE	15'	15'	10'	8'	8'	15'	10'	-
ORNAMENTAL/NATIVE DECIDUOUS TREE	6'	6'	10'	8'	8'	15'	10'	-
MEDIUM AND LARGE SHRUBS - GREATER THAN 3' TALL	5'	5'	8'	3'	3'	6'	5'	5'
SMALL SHRUB - LESS THAN 3' TALL	3'	5'	5'	2'	3'	2'	5'	5'

TYPICAL MINIMUM DISTANCE SETBACKS ARE TO THE CENTER STEM OR TRUNK OF PLANT MATERIAL UNLESS OTHERWISE DIRECTED BY THE ENGINEER DURING LAYOUT AND STAKING OF PLANT LOCATIONS.

**TREE RETENTION CALCULATION**

EXISTING SIGNIFICANT TREES ON SITE	22
TREES REMOVED FOR PROJECT	13
TREES RETAINED	41%
R-4 ZONE TREE RETENTION REQUIREMENT	35%
TREE REPLACEMENT REQUIRED AT 1 TO 1 RATIO	13
REPLACEMENT TREES PROPOSED	16

CITY OF SAMMAMISH APPROVAL	
City Engineer _____	Date _____
Community Development _____	Date _____

**Exhibit 13**  
**NOT FOR CONSTRUCTION**  
**SSDP2016-00414**  
**000200**

PLOTTED BY: purgaban DATE: Wednesday, October 12, 2016 1:22:55 PM  
 PATH: U:\PSO\Projects\Clients\1521-075-ELST\98Sves\CADD\Phase 21\T03\DWG\

REVISIONS	DATE	BY	DESIGNED
			J. SWENSON
			B. PURGANAN
			P. JOHANNESSEN
			Y. HO

**ONE INCH AT FULL SCALE, IF NOT, SCALE ACCORDINGLY**  
 FILE NAME: BL1521075P21T03LD-01  
 JOB No: 54-1521-075 P21T03  
 DATE: OCTOBER 2016

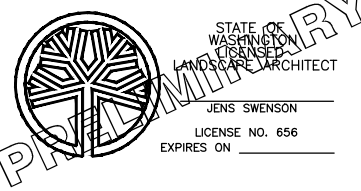

**Parametrix**  
 ENGINEERING . PLANNING . ENVIRONMENTAL SCIENCES  
 719 2ND AVENUE, SUITE 200 | SEATTLE, WA 98104  
 P 206.394.3700  
 WWW.PARAMETRIX.COM

PROJECT NAME  
**EAST LAKE SAMMAMISH MASTER PLAN TRAIL INGLEWOOD HILL ROAD PARKING LOT**  
 SAMMAMISH, WA

**PLANTING SCHEDULE AND DETAILS**

SHEET NO.  
 25 OF 27  
**LD1**





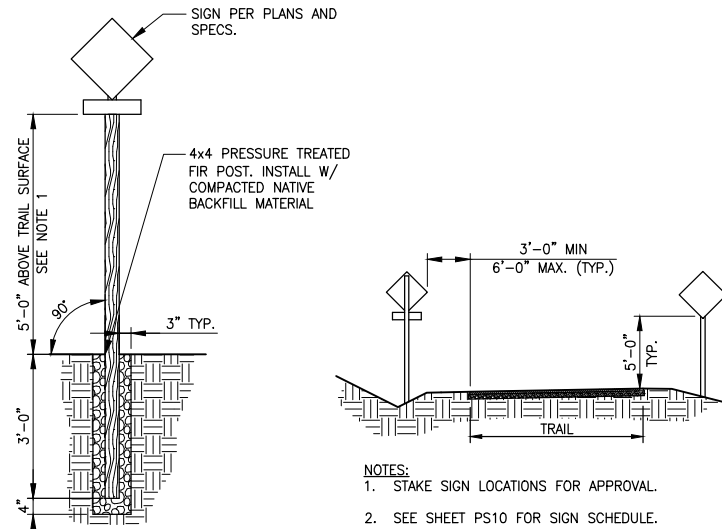

**TRAIL SIDE SIGNAGE**

- NOTES:
- USE 7' MOUNTING HEIGHT FOR TRAFFIC SIGNS ALONG ROADWAYS, SEE SPECIFICATIONS.
  - USE 5' MOUNTING HEIGHT FOR TRAIL SIGNS.

**TRAIL SIGNAGE  
DETAIL**

NOT TO SCALE



LAYOUT: MD1  
 PATH: U:\PSO\Projects\Clients\1521-KingCo\554-1521-075-ELST\99Specs\CADD\Phase 21\T03.Dwg  
 PLOTTED BY: purgbut DATE: Tuesday, October 11, 2016 8:06:42 PM

REVISIONS	DATE	BY	DESIGNED
			J. JUN
			DRAWN B. PURGANAN
			CHECKED P. JOHANNESSEN
			APPROVED Y. HO

ONE INCH AT FULL SCALE.  
IF NOT, SCALE ACCORDINGLY

FILE NAME  
BL1521075P21T03MD-01

JOB No.  
554-1521-075 P21T03

DATE  
OCTOBER 2016

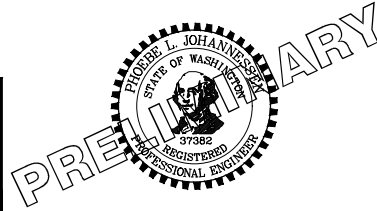

**Parametrix**  
ENGINEERING . PLANNING . ENVIRONMENTAL SCIENCES

719 2ND AVENUE, SUITE 200 | SEATTLE, WA 98104  
P 206.394.3700  
WWW.PARAMETRIX.COM

PROJECT NAME  
**EAST LAKE SAMMAMISH  
MASTER PLAN TRAIL  
INGLEWOOD HILL ROAD PARKING LOT**  
SAMMAMISH, WA

**MISCELLANEOUS DETAILS**

SHEET NO.  
27 OF 27

**MD1**

CITY OF SAMMAMISH APPROVAL	
City Engineer _____	Date _____
Community Development _____	Date _____

**Exhibit 13**  
**NOT FOR CONSTRUCTION**  
**SSDP2016-00414**  
**000202**



# Appendix B

## WWHM Report

WWHM2012  
PROJECT REPORT

---

Project Name: ParkingLotSizing  
Site Name:  
Site Address:  
City :  
Report Date: 10/13/2016  
Gage : Seatac  
Data Start : 1948/10/01  
Data End : 2009/09/30  
Precip Scale: 1.00  
Version Date: 2016/05/12  
Version : 4.2.12

---

Low Flow Threshold for POC 1 : 50 Percent of the 2 Year

---

High Flow Threshold for POC 1: 50 year

---

PREDEVELOPED LAND USE

Name : Basin 1  
Bypass: No

GroundWater: No

<u>Pervious Land Use</u>	<u>acre</u>
A B, Forest, Flat	.28
Pervious Total	0.28
<u>Impervious Land Use</u>	<u>acre</u>
Impervious Total	0
Basin Total	0.28

---

Element Flows To:  
Surface                      Interflow                      Groundwater

---

MITIGATED LAND USE

Name : Basin 1  
Bypass: No

GroundWater: No

Exhibit 13  
SSDP2016-00414  
000204

<u>Pervious Land Use</u>	<u>acre</u>
Pervious Total	0
<u>Impervious Land Use</u>	<u>acre</u>
SIDEWALKS FLAT	0.28
Impervious Total	0.28
Basin Total	0.28

---

Element Flows To:

Surface	Interflow	Groundwater
Gravel Trench Bed 1	Gravel Trench Bed 1	

---

Name : Gravel Trench Bed 1  
Bottom Length: 426.00 ft.  
Bottom Width: 2.20 ft.  
Trench bottom slope 1: 0 To 1  
Trench Left side slope 0: 0 To 1  
Trench right side slope 2: 0 To 1  
Material thickness of first layer: 2  
Pour Space of material for first layer: 0.3  
Material thickness of second layer: 0  
Pour Space of material for second layer: 0  
Material thickness of third layer: 0  
Pour Space of material for third layer: 0  
Infiltration On  
Infiltration rate: 10  
Infiltration safety factor: 1  
Total Volume Infiltrated (ac-ft.): 46.689  
Total Volume Through Riser (ac-ft.): 0  
Total Volume Through Facility (ac-ft.): 46.689  
Percent Infiltrated: 100  
Total Precip Applied to Facility: 3.286  
Total Evap From Facility: 0.297  
Discharge Structure  
Riser Height: 2 ft.  
Riser Diameter: 12 in.

Element Flows To:

Outlet 1	Outlet 2
----------	----------

---

**Gravel Trench Bed Hydraulic Table**

<u>Stage(feet)</u>	<u>Area(ac.)</u>	<u>Volume(ac-ft.)</u>	<u>Discharge(cfs)</u>	<u>Infilt(cfs)</u>
0.0000	0.021	0.000	0.000	0.000
0.0222	0.021	0.000	0.000	0.216
0.0444	0.021	0.000	0.000	0.216

**Exhibit 13**  
**SSDP2016-00414**  
**000205**

0.0667	0.021	0.000	0.000	0.216
0.0889	0.021	0.000	0.000	0.216
0.1111	0.021	0.000	0.000	0.216
0.1333	0.021	0.000	0.000	0.216
0.1556	0.021	0.001	0.000	0.216
0.1778	0.021	0.001	0.000	0.216
0.2000	0.021	0.001	0.000	0.216
0.2222	0.021	0.001	0.000	0.216
0.2444	0.021	0.001	0.000	0.216
0.2667	0.021	0.001	0.000	0.216
0.2889	0.021	0.001	0.000	0.216
0.3111	0.021	0.002	0.000	0.216
0.3333	0.021	0.002	0.000	0.216
0.3556	0.021	0.002	0.000	0.216
0.3778	0.021	0.002	0.000	0.216
0.4000	0.021	0.002	0.000	0.216
0.4222	0.021	0.002	0.000	0.216
0.4444	0.021	0.002	0.000	0.216
0.4667	0.021	0.003	0.000	0.216
0.4889	0.021	0.003	0.000	0.216
0.5111	0.021	0.003	0.000	0.216
0.5333	0.021	0.003	0.000	0.216
0.5556	0.021	0.003	0.000	0.216
0.5778	0.021	0.003	0.000	0.216
0.6000	0.021	0.003	0.000	0.216
0.6222	0.021	0.004	0.000	0.216
0.6444	0.021	0.004	0.000	0.216
0.6667	0.021	0.004	0.000	0.216
0.6889	0.021	0.004	0.000	0.216
0.7111	0.021	0.004	0.000	0.216
0.7333	0.021	0.004	0.000	0.216
0.7556	0.021	0.004	0.000	0.216
0.7778	0.021	0.005	0.000	0.216
0.8000	0.021	0.005	0.000	0.216
0.8222	0.021	0.005	0.000	0.216
0.8444	0.021	0.005	0.000	0.216
0.8667	0.021	0.005	0.000	0.216
0.8889	0.021	0.005	0.000	0.216
0.9111	0.021	0.005	0.000	0.216
0.9333	0.021	0.006	0.000	0.216
0.9556	0.021	0.006	0.000	0.216
0.9778	0.021	0.006	0.000	0.216
1.0000	0.021	0.006	0.000	0.216
1.0222	0.021	0.006	0.000	0.216
1.0444	0.021	0.006	0.000	0.216
1.0667	0.021	0.006	0.000	0.216
1.0889	0.021	0.007	0.000	0.216
1.1111	0.021	0.007	0.000	0.216
1.1333	0.021	0.007	0.000	0.216
1.1556	0.021	0.007	0.000	0.216
1.1778	0.021	0.007	0.000	0.216
1.2000	0.021	0.007	0.000	0.216
1.2222	0.021	0.007	0.000	0.216
1.2444	0.021	0.008	0.000	0.216
1.2667	0.021	0.008	0.000	0.216
1.2889	0.021	0.008	0.000	0.216
1.3111	0.021	0.008	0.000	0.216

1.3333	0.021	0.008	0.000	0.216
1.3556	0.021	0.008	0.000	0.216
1.3778	0.021	0.008	0.000	0.216
1.4000	0.021	0.009	0.000	0.216
1.4222	0.021	0.009	0.000	0.216
1.4444	0.021	0.009	0.000	0.216
1.4667	0.021	0.009	0.000	0.216
1.4889	0.021	0.009	0.000	0.216
1.5111	0.021	0.009	0.000	0.216
1.5333	0.021	0.009	0.000	0.216
1.5556	0.021	0.010	0.000	0.216
1.5778	0.021	0.010	0.000	0.216
1.6000	0.021	0.010	0.000	0.216
1.6222	0.021	0.010	0.000	0.216
1.6444	0.021	0.010	0.000	0.216
1.6667	0.021	0.010	0.000	0.216
1.6889	0.021	0.010	0.000	0.216
1.7111	0.021	0.011	0.000	0.216
1.7333	0.021	0.011	0.000	0.216
1.7556	0.021	0.011	0.000	0.216
1.7778	0.021	0.011	0.000	0.216
1.8000	0.021	0.011	0.000	0.216
1.8222	0.021	0.011	0.000	0.216
1.8444	0.021	0.011	0.000	0.216
1.8667	0.021	0.012	0.000	0.216
1.8889	0.021	0.012	0.000	0.216
1.9111	0.021	0.012	0.000	0.216
1.9333	0.021	0.012	0.000	0.216
1.9556	0.021	0.012	0.000	0.216
1.9778	0.021	0.012	0.000	0.216
2.0000	0.021	0.012	0.000	0.216

---



---

**ANALYSIS RESULTS**

**POC #1 was not reported because POC must exist in both scenarios and both scenarios must have been run.Perlnd and Implnd Changes**

No changes have been made.

---

This program and accompanying documentation are provided 'as-is' without warranty of any kind. The entire risk regarding the performance and results of this program is assumed by End User. Clear Creek Solutions Inc. and the governmental licensee or sublicensees disclaim all warranties, either expressed or implied, including but not limited to implied warranties of program and accompanying documentation. In no event shall Clear Creek Solutions Inc. be liable for any damages whatsoever (including without limitation to damages for loss of business profits, loss of business information, business interruption, and the like) arising out of the use of, or inability to use this program even if Clear Creek Solutions Inc. or their authorized representatives have been advised of the possibility of such damages. Software Copyright © by : Clear Creek Solutions, Inc. 2005-2016; All Rights Reserved.

**Exhibit 13**  
**SSDP2016-00414**  
**000207**

**WWHM2012**  
**PROJECT REPORT**

**Exhibit 13**  
**SSDP2016-00414**  
**000208**

## General Model Information

Project Name: ParkingLotSizing  
Site Name:  
Site Address:  
City:  
Report Date: 10/13/2016  
Gage: Seatac  
Data Start: 1948/10/01  
Data End: 2009/09/30  
Timestep: Hourly  
Precip Scale: 1.000  
Version Date: 2016/05/12  
Version: 4.2.12

## POC Thresholds

---

Low Flow Threshold for POC1: 50 Percent of the 2 Year  
High Flow Threshold for POC1: 50 Year

---

**Exhibit 13**  
**SSDP2016-00414**  
**000209**

*Landuse Basin Data*  
*Predeveloped Land Use*

**Basin 1**

Bypass: No

GroundWater: No

Pervious Land Use acre  
A B, Forest, Flat 0.28

Pervious Total 0.28

Impervious Land Use acre

Impervious Total 0

Basin Total 0.28

Element Flows To:  
Surface Interflow Groundwater

DRAFT

**Exhibit 13**  
**SSDP2016-00414**  
**000210**



*Mitigated Land Use*

**Basin 1**

Bypass:	No
GroundWater:	No
Pervious Land Use	acre
Pervious Total	0
Impervious Land Use	acre
SIDEWALKS FLAT	0.28
Impervious Total	0.28
Basin Total	0.28

Element Flows To:

Surface	Interflow	Groundwater
Gravel Trench Bed 1	Gravel Trench Bed 1	

DRAFT

**Exhibit 13**  
**SSDP2016-00414**  
**000211**

*Routing Elements*  
*Predeveloped Routing*

DRAFT

**Exhibit 13**  
**SSDP2016-00414**  
**000212**

## Mitigated Routing

### Gravel Trench Bed 1

Bottom Length:	426.00 ft.
Bottom Width:	2.20 ft.
Trench bottom slope 1:	0 To 1
Trench Left side slope 0:	0 To 1
Trench right side slope 2:	0 To 1
Material thickness of first layer:	2
Pour Space of material for first layer:	0.3
Material thickness of second layer:	0
Pour Space of material for second layer:	0
Material thickness of third layer:	0
Pour Space of material for third layer:	0
Infiltration On	
Infiltration rate:	10
Infiltration safety factor:	1
Total Volume Infiltrated (ac-ft.):	46.689
Total Volume Through Riser (ac-ft.):	0
Total Volume Through Facility (ac-ft.):	46.689
Percent Infiltrated:	100
Total Precip Applied to Facility:	3.286
Total Evap From Facility:	0.297
Discharge Structure	
Riser Height:	2 ft.
Riser Diameter:	12 in.
Element Flows To:	
Outlet 1	Outlet 2

Gravel Trench Bed Hydraulic Table

Stage(feet)	Area(ac.)	Volume(ac-ft.)	Discharge(cfs)	Infilt(cfs)
0.0000	0.021	0.000	0.000	0.000
0.0222	0.021	0.000	0.000	0.216
0.0444	0.021	0.000	0.000	0.216
0.0667	0.021	0.000	0.000	0.216
0.0889	0.021	0.000	0.000	0.216
0.1111	0.021	0.000	0.000	0.216
0.1333	0.021	0.000	0.000	0.216
0.1556	0.021	0.001	0.000	0.216
0.1778	0.021	0.001	0.000	0.216
0.2000	0.021	0.001	0.000	0.216
0.2222	0.021	0.001	0.000	0.216
0.2444	0.021	0.001	0.000	0.216
0.2667	0.021	0.001	0.000	0.216
0.2889	0.021	0.001	0.000	0.216
0.3111	0.021	0.002	0.000	0.216
0.3333	0.021	0.002	0.000	0.216
0.3556	0.021	0.002	0.000	0.216
0.3778	0.021	0.002	0.000	0.216
0.4000	0.021	0.002	0.000	0.216
0.4222	0.021	0.002	0.000	0.216
0.4444	0.021	0.002	0.000	0.216
0.4667	0.021	0.003	0.000	0.216
0.4889	0.021	0.003	0.000	0.216
0.5111	0.021	0.003	0.000	0.216

**Exhibit 13**  
**SSDP2016-00414**  
**000213**

0.5333	0.021	0.003	0.000	0.216
0.5556	0.021	0.003	0.000	0.216
0.5778	0.021	0.003	0.000	0.216
0.6000	0.021	0.003	0.000	0.216
0.6222	0.021	0.004	0.000	0.216
0.6444	0.021	0.004	0.000	0.216
0.6667	0.021	0.004	0.000	0.216
0.6889	0.021	0.004	0.000	0.216
0.7111	0.021	0.004	0.000	0.216
0.7333	0.021	0.004	0.000	0.216
0.7556	0.021	0.004	0.000	0.216
0.7778	0.021	0.005	0.000	0.216
0.8000	0.021	0.005	0.000	0.216
0.8222	0.021	0.005	0.000	0.216
0.8444	0.021	0.005	0.000	0.216
0.8667	0.021	0.005	0.000	0.216
0.8889	0.021	0.005	0.000	0.216
0.9111	0.021	0.005	0.000	0.216
0.9333	0.021	0.006	0.000	0.216
0.9556	0.021	0.006	0.000	0.216
0.9778	0.021	0.006	0.000	0.216
1.0000	0.021	0.006	0.000	0.216
1.0222	0.021	0.006	0.000	0.216
1.0444	0.021	0.006	0.000	0.216
1.0667	0.021	0.006	0.000	0.216
1.0889	0.021	0.007	0.000	0.216
1.1111	0.021	0.007	0.000	0.216
1.1333	0.021	0.007	0.000	0.216
1.1556	0.021	0.007	0.000	0.216
1.1778	0.021	0.007	0.000	0.216
1.2000	0.021	0.007	0.000	0.216
1.2222	0.021	0.007	0.000	0.216
1.2444	0.021	0.008	0.000	0.216
1.2667	0.021	0.008	0.000	0.216
1.2889	0.021	0.008	0.000	0.216
1.3111	0.021	0.008	0.000	0.216
1.3333	0.021	0.008	0.000	0.216
1.3556	0.021	0.008	0.000	0.216
1.3778	0.021	0.008	0.000	0.216
1.4000	0.021	0.009	0.000	0.216
1.4222	0.021	0.009	0.000	0.216
1.4444	0.021	0.009	0.000	0.216
1.4667	0.021	0.009	0.000	0.216
1.4889	0.021	0.009	0.000	0.216
1.5111	0.021	0.009	0.000	0.216
1.5333	0.021	0.009	0.000	0.216
1.5556	0.021	0.010	0.000	0.216
1.5778	0.021	0.010	0.000	0.216
1.6000	0.021	0.010	0.000	0.216
1.6222	0.021	0.010	0.000	0.216
1.6444	0.021	0.010	0.000	0.216
1.6667	0.021	0.010	0.000	0.216
1.6889	0.021	0.010	0.000	0.216
1.7111	0.021	0.011	0.000	0.216
1.7333	0.021	0.011	0.000	0.216
1.7556	0.021	0.011	0.000	0.216
1.7778	0.021	0.011	0.000	0.216
1.8000	0.021	0.011	0.000	0.216

DRAFT

Exhibit 13  
SSDP2016-00414  
000214

1.8222	0.021	0.011	0.000	0.216
1.8444	0.021	0.011	0.000	0.216
1.8667	0.021	0.012	0.000	0.216
1.8889	0.021	0.012	0.000	0.216
1.9111	0.021	0.012	0.000	0.216
1.9333	0.021	0.012	0.000	0.216
1.9556	0.021	0.012	0.000	0.216
1.9778	0.021	0.012	0.000	0.216
2.0000	0.021	0.012	0.000	0.216

DRAFT

**Exhibit 13**  
**SSDP2016-00414**  
**000215**

## Analysis Results

### POC 1

POC #1 was not reported because POC must exist in both scenarios and both scenarios must have been run.

DRAFT

**Exhibit 13**  
**SSDP2016-00414**  
**000216**

## *Model Default Modifications*

Total of 0 changes have been made.

### *PERLND Changes*

No PERLND changes have been made.

### *IMPLND Changes*

No IMPLND changes have been made.

DRAFT

**Exhibit 13**  
**SSDP2016-00414**  
**000217**

*Appendix*  
*Predeveloped Schematic*



**Exhibit 13**  
**SSDP2016-00414**  
**000218**



Mitigated Schematic



**Exhibit 13**  
**SSDP2016-00414**  
**000219**

DRAFT

**Exhibit 13**  
**SSDP2016-00414**  
**000220**

# Mitigated UCI File

RUN

```
GLOBAL
  WWHM4 model simulation
  START      1948 10 01      END      2009 09 30
  RUN INTERP OUTPUT LEVEL    3      0
  RESUME     0 RUN          1
  UNIT SYSTEM          1
END GLOBAL
```

```
FILES
<File> <Un#> <-----File Name----->***
<-ID->                                     ***
WDM      26    ParkingLotSizing.wdm
MESSU    25    MitParkingLotSizing.MES
          27    MitParkingLotSizing.L61
          28    MitParkingLotSizing.L62
          30    POCParkingLotSizing1.dat
END FILES
```

```
OPN SEQUENCE
  INGRP          INDELT 00:60
  IMPLND         8
  RCHRES         1
  COPY           1
  COPY          501
  DISPLY         1
  END INGRP
END OPN SEQUENCE
```

```
DISPLY
  DISPLY-INFO1
  # - #<-----Title----->***TRAN PIVL DIG1 FIL1  PYR DIG2 FIL2 YRND
  1   1   Gravel Trench Bed 1      MAX          1   2   30   9
  END DISPLY-INFO1
```

```
END DISPLY
COPY
  TIMESERIES
  # - # NPT NMN ***
  1   1   1   1
  501 1   1   1
  END TIMESERIES
```

```
END COPY
GENER
  OPCODE
  #   # OPCD ***
  END OPCODE
  PARM
  #   #           K ***
  END PARM
```

```
END GENER
PERLND
  GEN-INFO
  <PLS ><-----Name----->NBLKS  Unit-systems  Printer ***
  # - #                               User  t-series  Engl Metr ***
  # - #                               in   out      ***
  END GEN-INFO
  *** Section PWATER***
```

```
ACTIVITY
  <PLS > ***** Active Sections *****
  # - # ATMP SNOW PWAT  SED  PST  PWG  PQAL MSTL  PEST  NITR  PHOS  TRAC  ***
  END ACTIVITY
```

```
PRINT-INFO
  <PLS > ***** Print-flags ***** PIVL  PYR
  # - # ATMP SNOW PWAT  SED  PST  PWG  PQAL MSTL  PEST  NITR  PHOS  TRAC  *****
  END PRINT-INFO
```

PWAT-PARM1

**Exhibit 13**  
**SSDP2016-00414**  
**000221**

<PLS > PWATER variable monthly parameter value flags \*\*\*  
# - # CSNO RTOP UZFG VCS VUZ VNN VIFW VIRG VLE INFC HWT \*\*\*  
END PWAT-PARM1

PWAT-PARM2  
<PLS > PWATER input info: Part 2 \*\*\*  
# - # \*\*\*FOREST LZSN INFILT LSUR SLSUR KVARY AGWRC  
END PWAT-PARM2

PWAT-PARM3  
<PLS > PWATER input info: Part 3 \*\*\*  
# - # \*\*\*PETMAX PETMIN INFEXP INFILD DEEPFR BASETP AGWETP  
END PWAT-PARM3

PWAT-PARM4  
<PLS > PWATER input info: Part 4 \*\*\*  
# - # CEPSC UZSN NSUR INTFW IRC LZETP \*\*\*  
END PWAT-PARM4

PWAT-STATE1  
<PLS > \*\*\* Initial conditions at start of simulation  
ran from 1990 to end of 1992 (pat 1-11-95) RUN 21 \*\*\*  
# - # \*\*\* CEPS SURS UZS IFWS LZS AGWS GWVS  
END PWAT-STATE1

END PERLND

IMPLND

GEN-INFO  
<PLS ><-----Name-----> Unit-systems Printer \*\*\*  
# - # User t-series Engl Metr \*\*\*  
in out \*\*\*  
8 SIDEWALKS/FLAT 1 1 1 27 0  
END GEN-INFO  
\*\*\* Section IWATER\*\*\*

ACTIVITY  
<PLS > \*\*\*\*\* Active Sections \*\*\*\*\*  
# - # ATMP SNOW IWAT SLD IWG IQAL \*\*\*  
8 0 0 1 0 0 0  
END ACTIVITY

PRINT-INFO  
<ILS > \*\*\*\*\* Print-flags \*\*\*\*\* PIVL PYR  
# - # ATMP SNOW IWAT SLD IWG IQAL \*\*\*\*\*  
8 0 0 4 0 0 0 1 9  
END PRINT-INFO

IWAT-PARM1  
<PLS > IWATER variable monthly parameter value flags \*\*\*  
# - # CSNO RTOP VRS VNN RTLI \*\*\*  
8 0 0 0 0 0  
END IWAT-PARM1

IWAT-PARM2  
<PLS > IWATER input info: Part 2 \*\*\*  
# - # \*\*\* LSUR SLSUR NSUR RETSC  
8 400 0.01 0.1 0.1  
END IWAT-PARM2

IWAT-PARM3  
<PLS > IWATER input info: Part 3 \*\*\*  
# - # \*\*\*PETMAX PETMIN  
8 0 0  
END IWAT-PARM3

IWAT-STATE1  
<PLS > \*\*\* Initial conditions at start of simulation  
# - # \*\*\* RETS SURS  
8 0 0  
END IWAT-STATE1

**Exhibit 13**  
**SSDP2016-00414**  
**00022**

END IMPLND

SCHEMATIC

<-Source->	<--Area-->	<-Target->	MBLK	***
<Name> #	<-factor->	<Name> #	Tbl#	***
Basin 1***				
IMPLND 8	0.28	RCHRES 1	5	

\*\*\*\*\*Routing\*\*\*\*\*

IMPLND 8	0.28	COPY 1	15
RCHRES 1	1	COPY 501	17

END SCHEMATIC

NETWORK

<-Volume->	<-Grp>	<-Member->	<--Mult-->	Tran	<-Target vols>	<-Grp>	<-Member->	***
<Name> #		<Name> #	#	<-factor->	strg	<Name> #	#	<Name> # #
COPY 501	OUTPUT	MEAN	1	1	12.1	DISPLY	1	INPUT TIMSER 1

<-Volume->	<-Grp>	<-Member->	<--Mult-->	Tran	<-Target vols>	<-Grp>	<-Member->	***
<Name> #		<Name> #	#	<-factor->	strg	<Name> #	#	<Name> # #

END NETWORK

RCHRES

GEN-INFO

RCHRES	Name	Nexits	Unit	Systems	Printer	***
# - #	<----->	<----->	User	T-series	Engl Metr LKFG	***
			in	out		***
1	Gravel Trench Be-017	2	1	1 1	28 0 1	

END GEN-INFO

\*\*\* Section RCHRES\*\*\*

ACTIVITY

<PLS >	***** Active Sections *****										
# - #	HYFG	ADFG	CNFG	HTFG	SDFG	GQFG	OXFG	NUFG	PKFG	PHFG	***
1	1	0	0	0	0	0	0	0	0	0	

END ACTIVITY

PRINT-INFO

<PLS >	***** Print-flags *****										PIVL	PYR	***
# - #	HYDR	ADCA	CONS	HEAT	SED	GQL	OXRX	NUTR	PLNK	PHCB	PIVL	PYR	*****
1	4	0	0	0	0	0	0	0	0	0	1	9	

END PRINT-INFO

HYDR-PARM1

RCHRES	Flags for each HYDR Section	***	ODGTFG for each	FUNCT for each	***
# - #	VC A1 A2 A3	ODFVFG for each	*** possible exit	*** possible exit	possible exit
	FG FG FG FG	* * * * *	* * * * *	* * * * *	***
1	0 1 0 0	4 5 0 0 0	0 0 0 0 0	2 2 2 2 2	

END HYDR-PARM1

HYDR-PARM2

# - #	FTABNO	LEN	DELTH	STCOR	KS	DB50	***
<----->	<----->	<----->	<----->	<----->	<----->	<----->	***
1	1	0.08	0.0	0.0	0.5	0.0	

END HYDR-PARM2

HYDR-INIT

RCHRES	Initial conditions for each HYDR section	***
# - #	*** VOL	Initial value of COLIND
	*** ac-ft	for each possible exit
		Initial value of OUTDGT
		for each possible exit
1	0	4.0 5.0 0.0 0.0 0.0
		0.0 0.0 0.0 0.0 0.0

END HYDR-INIT

END RCHRES

SPEC-ACTIONS

END SPEC-ACTIONS

**Exhibit 13**  
**SSDP2016-00414**  
**000223**

FTABLES

FTABLE

1

92 5

Depth (ft)	Area (acres)	Volume (acre-ft)	Outflow1 (cfs)	Outflow2 (cfs)	Velocity (ft/sec)	Travel Time*** (Minutes)***
0.000000	0.021515	0.000000	0.000000	0.000000		
0.022222	0.021515	0.000143	0.000000	0.000000		
0.044444	0.021515	0.000287	0.000000	0.000000		
0.066667	0.021515	0.000430	0.000000	0.000000		
0.088889	0.021515	0.000574	0.000000	0.000000		
0.111111	0.021515	0.000717	0.000000	0.000000		
0.133333	0.021515	0.000861	0.000000	0.000000		
0.155556	0.021515	0.001004	0.000000	0.000000		
0.177778	0.021515	0.001147	0.000000	0.000000		
0.200000	0.021515	0.001291	0.000000	0.000000		
0.222222	0.021515	0.001434	0.000000	0.000000		
0.244444	0.021515	0.001578	0.000000	0.000000		
0.266667	0.021515	0.001721	0.000000	0.000000		
0.288889	0.021515	0.001865	0.000000	0.000000		
0.311111	0.021515	0.002008	0.000000	0.000000		
0.333333	0.021515	0.002152	0.000000	0.000000		
0.355556	0.021515	0.002295	0.000000	0.000000		
0.377778	0.021515	0.002438	0.000000	0.000000		
0.400000	0.021515	0.002582	0.000000	0.000000		
0.422222	0.021515	0.002725	0.000000	0.000000		
0.444444	0.021515	0.002869	0.000000	0.000000		
0.466667	0.021515	0.003012	0.000000	0.000000		
0.488889	0.021515	0.003156	0.000000	0.000000		
0.511111	0.021515	0.003299	0.000000	0.000000		
0.533333	0.021515	0.003442	0.000000	0.000000		
0.555556	0.021515	0.003586	0.000000	0.000000		
0.577778	0.021515	0.003729	0.000000	0.000000		
0.600000	0.021515	0.003873	0.000000	0.000000		
0.622222	0.021515	0.004016	0.000000	0.000000		
0.644444	0.021515	0.004160	0.000000	0.000000		
0.666667	0.021515	0.004303	0.000000	0.000000		
0.688889	0.021515	0.004446	0.000000	0.000000		
0.711111	0.021515	0.004590	0.000000	0.000000		
0.733333	0.021515	0.004733	0.000000	0.000000		
0.755556	0.021515	0.004877	0.000000	0.000000		
0.777778	0.021515	0.005020	0.000000	0.000000		
0.800000	0.021515	0.005164	0.000000	0.000000		
0.822222	0.021515	0.005307	0.000000	0.000000		
0.844444	0.021515	0.005451	0.000000	0.000000		
0.866667	0.021515	0.005594	0.000000	0.000000		
0.888889	0.021515	0.005737	0.000000	0.000000		
0.911111	0.021515	0.005881	0.000000	0.000000		
0.933333	0.021515	0.006024	0.000000	0.000000		
0.955556	0.021515	0.006168	0.000000	0.000000		
0.977778	0.021515	0.006311	0.000000	0.000000		
1.000000	0.021515	0.006455	0.000000	0.000000		
1.022222	0.021515	0.006598	0.000000	0.000000		
1.044444	0.021515	0.006741	0.000000	0.000000		
1.066667	0.021515	0.006885	0.000000	0.000000		
1.088889	0.021515	0.007028	0.000000	0.000000		
1.111111	0.021515	0.007172	0.000000	0.000000		
1.133333	0.021515	0.007315	0.000000	0.000000		
1.155556	0.021515	0.007459	0.000000	0.000000		
1.177778	0.021515	0.007602	0.000000	0.000000		
1.200000	0.021515	0.007745	0.000000	0.000000		
1.222222	0.021515	0.007889	0.000000	0.000000		
1.244444	0.021515	0.008032	0.000000	0.000000		
1.266667	0.021515	0.008176	0.000000	0.000000		
1.288889	0.021515	0.008319	0.000000	0.000000		
1.311111	0.021515	0.008463	0.000000	0.000000		
1.333333	0.021515	0.008606	0.000000	0.000000		
1.355556	0.021515	0.008749	0.000000	0.000000		
1.377778	0.021515	0.008893	0.000000	0.000000		
1.400000	0.021515	0.009036	0.000000	0.000000		
1.422222	0.021515	0.009180	0.000000	0.000000		

**Exhibit 13**  
**SSDP2016-00414**  
**000224**

1.444444	0.021515	0.009323	0.000000	0.216944
1.466667	0.021515	0.009467	0.000000	0.216944
1.488889	0.021515	0.009610	0.000000	0.216944
1.511111	0.021515	0.009754	0.000000	0.216944
1.533333	0.021515	0.009897	0.000000	0.216944
1.555556	0.021515	0.010040	0.000000	0.216944
1.577778	0.021515	0.010184	0.000000	0.216944
1.600000	0.021515	0.010327	0.000000	0.216944
1.622222	0.021515	0.010471	0.000000	0.216944
1.644444	0.021515	0.010614	0.000000	0.216944
1.666667	0.021515	0.010758	0.000000	0.216944
1.688889	0.021515	0.010901	0.000000	0.216944
1.711111	0.021515	0.011044	0.000000	0.216944
1.733333	0.021515	0.011188	0.000000	0.216944
1.755556	0.021515	0.011331	0.000000	0.216944
1.777778	0.021515	0.011475	0.000000	0.216944
1.800000	0.021515	0.011618	0.000000	0.216944
1.822222	0.021515	0.011762	0.000000	0.216944
1.844444	0.021515	0.011905	0.000000	0.216944
1.866667	0.021515	0.012048	0.000000	0.216944
1.888889	0.021515	0.012192	0.000000	0.216944
1.911111	0.021515	0.012335	0.000000	0.216944
1.933333	0.021515	0.012479	0.000000	0.216944
1.955556	0.021515	0.012622	0.000000	0.216944
1.977778	0.021515	0.012766	0.000000	0.216944
2.000000	0.021515	0.012909	0.000000	0.216944
2.022222	0.021515	0.013387	0.035147	0.216944

END FTABLE 1

END FTABLES

EXT SOURCES

<-Volume->	<Member>	SsysSgap	<--Mult-->	Tran	<-Target	vols>	<-Grp>	<-Member-->	***				
<Name>	#	<Name>	#	tem strg	<-factor-->	strg	<Name>	#	#	<Name>	#	#	***
WDM	2	PREC		ENGL	1	SUM	PERLND	1	999	EXTNL	PREC		
WDM	2	PREC		ENGL	1	SUM	IMPLND	1	999	EXTNL	PREC		
WDM	1	EVAP		ENGL	0.76		PERLND	1	999	EXTNL	PETINP		
WDM	1	EVAP		ENGL	0.76		IMPLND	1	999	EXTNL	PETINP		
WDM	2	PREC		ENGL	1	SUM	RCHRES	1		EXTNL	PREC		
WDM	1	EVAP		ENGL	0.76		RCHRES	1		EXTNL	POTEV		

END EXT SOURCES

EXT TARGETS

<-Volume->	<-Grp>	<-Member-->	<--Mult-->	Tran	<-Volume->	<Member>	Tsys	Tgap	Amd	***		
<Name>	#	<Name>	#	#	<-factor-->	strg	<Name>	#	<Name>	tem strg	strg	***
RCHRES	1	HYDR	RO	1	1	1	WDM	1008	FLOW	ENGL	REPL	
RCHRES	1	HYDR	O	1	1	1	WDM	1009	FLOW	ENGL	REPL	
RCHRES	1	HYDR	O	2	1	1	WDM	1010	FLOW	ENGL	REPL	
RCHRES	1	HYDR	STAGE	1	1	1	WDM	1011	STAG	ENGL	REPL	
COPY	1	OUTPUT	MEAN	1	1	12.1	WDM	701	FLOW	ENGL	REPL	
COPY	501	OUTPUT	MEAN	1	1	12.1	WDM	801	FLOW	ENGL	REPL	

END EXT TARGETS

MASS-LINK

<Volume>	<-Grp>	<-Member-->	<--Mult-->	<Target>	<-Grp>	<-Member-->	***	
<Name>	#	<Name>	#	<-factor-->	<Name>	#	#	***
MASS-LINK		5						
IMPLND	IWATER	SURO		0.083333	RCHRES	INFLOW	IVOL	
END MASS-LINK		5						
MASS-LINK		15						
IMPLND	IWATER	SURO		0.083333	COPY	INPUT	MEAN	
END MASS-LINK		15						
MASS-LINK		17						
RCHRES	OFLOW	OVOL	1		COPY	INPUT	MEAN	
END MASS-LINK		17						

END MASS-LINK

**Exhibit 13**  
**SSDP2016-00414**  
**000225**



END RUN

DRAFT

**Exhibit 13**  
**SSDP2016-00414**  
**000226**

DRAFT

**Exhibit 13**  
**SSDP2016-00414**  
**000227**

DRAFT

**Exhibit 13**  
**SSDP2016-00414**  
**000228**

## *Disclaimer*

### *Legal Notice*

This program and accompanying documentation are provided 'as-is' without warranty of any kind. The entire risk regarding the performance and results of this program is assumed by End User. Clear Creek Solutions Inc. and the governmental licensee or sublicensees disclaim all warranties, either expressed or implied, including but not limited to implied warranties of program and accompanying documentation. In no event shall Clear Creek Solutions Inc. be liable for any damages whatsoever (including without limitation to damages for loss of business profits, loss of business information, business interruption, and the like) arising out of the use of, or inability to use this program even if Clear Creek Solutions Inc. or their authorized representatives have been advised of the possibility of such damages. Software Copyright © by : Clear Creek Solutions, Inc. 2005-2016; All Rights Reserved.

Clear Creek Solutions, Inc.  
6200 Capitol Blvd. Ste F  
Olympia, WA. 98501  
Toll Free 1(866)943-0304  
Local (360)943-0304

[www.clearcreeksolutions.com](http://www.clearcreeksolutions.com)

DRAFT

**Exhibit 13**  
**SSDP2016-00414**  
**000229**

# Appendix C

## Maintenance Requirements

**Exhibit 13**  
**SSDP2016-00414**  
**000230**

DRAFT

<b>NO. 2 – INFILTRATION FACILITIES</b>			
<b>Maintenance Component</b>	<b>Defect or Problem</b>	<b>Conditions When Maintenance Is Needed</b>	<b>Results Expected When Maintenance Is Performed</b>
Site	Trash and debris	Any trash and debris which exceed 1 cubic foot per 1,000 square feet (this is about equal to the amount of trash it would take to fill up one standard size office garbage can). In general, there should be no visual evidence of dumping.	Trash and debris cleared from site.
	Noxious weeds	Any noxious or nuisance vegetation which may constitute a hazard to County personnel or the public.	Noxious and nuisance vegetation removed according to applicable regulations. No danger of noxious vegetation where County personnel or the public might normally be.
	Contaminants and pollution	Any evidence of contaminants or pollution such as oil, gasoline, concrete slurries or paint.	Materials removed and disposed of according to applicable regulations. Source control BMPs implemented if appropriate. No contaminants present other than a surface oil film.
	Grass/groundcover	Grass or groundcover exceeds 18 inches in height.	Grass or groundcover mowed to a height no greater than 6 inches.
Infiltration Pond, Top or Side Slopes of Dam, Berm or Embankment	Rodent holes	Any evidence of rodent holes if facility is acting as a dam or berm, or any evidence of water piping through dam or berm via rodent holes.	Rodents removed or destroyed and dam or berm repaired.
	Tree growth	Tree growth threatens integrity of dams, berms or slopes, does not allow maintenance access, or interferes with maintenance activity. If trees are not a threat to dam, berm, or embankment integrity or not interfering with access or maintenance, they do not need to be removed.	Trees do not hinder facility performance or maintenance activities.
	Erosion	Eroded damage over 2 inches deep where cause of damage is still present or where there is potential for continued erosion. Any erosion observed on a compacted slope.	Slopes stabilized using appropriate erosion control measures. If erosion is occurring on compacted slope, a licensed civil engineer should be consulted to resolve source of erosion.
	Settlement	Any part of a dam, berm or embankment that has settled 4 inches lower than the design elevation.	Top or side slope restored to design dimensions. If settlement is significant, a licensed civil engineer should be consulted to determine the cause of the settlement.
Infiltration Pond, Tank, Vault, Trench, or Small Basin Storage Area	Sediment accumulation	If two inches or more sediment is present or a percolation test indicates facility is working at or less than 90% of design.	Facility infiltrates as designed.
	Liner damaged (If Applicable)	Liner is visible or pond does not hold water as designed.	Liner repaired or replaced.
Infiltration Tank Structure	Plugged air vent	Any blockage of the vent.	Tank or vault freely vents.
	Tank bent out of shape	Any part of tank/pipe is bent out of shape more than 10% of its design shape.	Tank repaired or replaced to design.
	Gaps between sections, damaged joints or cracks or tears in wall	A gap wider than ½-inch at the joint of any tank sections or any evidence of soil particles entering the tank at a joint or through a wall.	No water or soil entering tank through joints or walls.
Infiltration Vault Structure	Damage to wall, frame, bottom, and/or top slab	Cracks wider than ½-inch, any evidence of soil entering the structure through cracks or qualified inspection personnel determines that the vault is not structurally sound.	Vault is sealed and structurally sound.

**Exhibit 13**  
**SSDP2016-00414**  
**000232**



<b>NO. 2 – INFILTRATION FACILITIES</b>			
<b>Maintenance Component</b>	<b>Defect or Problem</b>	<b>Conditions When Maintenance Is Needed</b>	<b>Results Expected When Maintenance Is Performed</b>
Inlet/Outlet Pipes	Sediment accumulation	Sediment filling 20% or more of the pipe.	Inlet/outlet pipes clear of sediment.
	Trash and debris	Trash and debris accumulated in inlet/outlet pipes (includes floatables and non-floatables).	No trash or debris in pipes.
	Damaged	Cracks wider than ½-inch at the joint of the inlet/outlet pipes or any evidence of soil entering at the joints of the inlet/outlet pipes.	No cracks more than ¼-inch wide at the joint of the inlet/outlet pipe.
Access Manhole	Cover/lid not in place	Cover/lid is missing or only partially in place. <b>Any open manhole requires immediate maintenance.</b>	Manhole access covered.
	Locking mechanism not working	Mechanism cannot be opened by one maintenance person with proper tools. Bolts cannot be seated. Self-locking cover/lid does not work.	Mechanism opens with proper tools.
	Cover/lid difficult to remove	One maintenance person cannot remove cover/lid after applying 80 lbs of lift.	Cover/lid can be removed and reinstalled by one maintenance person.
	Ladder rungs unsafe	Missing rungs, misalignment, rust, or cracks.	Ladder meets design standards. Allows maintenance person safe access.
Large access doors/plate	Damaged or difficult to open	Large access doors or plates cannot be opened/removed using normal equipment.	Replace or repair access door so it can be opened as designed.
	Gaps, doesn't cover completely	Large access doors not flat and/or access opening not completely covered.	Doors close flat and covers access opening completely.
	Lifting Rings missing, rusted	Lifting rings not capable of lifting weight of door or plate.	Lifting rings sufficient to lift or remove door or plate.
Infiltration Pond, Tank, Vault, Trench, or Small Basin Filter Bags	Plugged	Filter bag more than ½ full.	Replace filter bag or redesign system.
Infiltration Pond, Tank, Vault, Trench, or Small Basin Pre-settling Ponds and Vaults	Sediment accumulation	6" or more of sediment has accumulated.	Pre-settling occurs as designed
Infiltration Pond, Rock Filter	Plugged	High water level on upstream side of filter remains for extended period of time or little or no water flows through filter during heavy rain storms.	Rock filter replaced evaluate need for filter and remove if not necessary.
Infiltration Pond Emergency Overflow Spillway	Rock missing	Only one layer of rock exists above native soil in area five square feet or larger, or any exposure of native soil at the top of out flow path of spillway. Rip-rap on inside slopes need not be replaced.	Spillway restored to design standards.
	Tree growth	Tree growth impedes flow or threatens stability of spillway.	Trees removed.

**Exhibit 13**  
**SSDP2016-00414**  
**000233**

<b>NO. 4 – CONTROL STRUCTURE/FLOW RESTRICTOR</b>			
<b>Maintenance Component</b>	<b>Defect or Problem</b>	<b>Condition When Maintenance is Needed</b>	<b>Results Expected When Maintenance is Performed</b>
Structure	Trash and debris	Trash or debris of more than ½ cubic foot which is located immediately in front of the structure opening or is blocking capacity of the structure by more than 10%.	No Trash or debris blocking or potentially blocking entrance to structure.
		Trash or debris in the structure that exceeds 1/3 the depth from the bottom of basin to invert the lowest pipe into or out of the basin.	No trash or debris in the structure.
		Deposits of garbage exceeding 1 cubic foot in volume.	No condition present which would attract or support the breeding of insects or rodents.
	Sediment	Sediment exceeds 60% of the depth from the bottom of the structure to the invert of the lowest pipe into or out of the structure or the bottom of the FROP-T section or is within 6 inches of the invert of the lowest pipe into or out of the structure or the bottom of the FROP-T section.	Sump of structure contains no sediment.
	Damage to frame and/or top slab	Corner of frame extends more than ¾ inch past curb face into the street (If applicable).	Frame is even with curb.
		Top slab has holes larger than 2 square inches or cracks wider than ¼ inch.	Top slab is free of holes and cracks.
		Frame not sitting flush on top slab, i.e., separation of more than ¾ inch of the frame from the top slab.	Frame is sitting flush on top slab.
	Cracks in walls or bottom	Cracks wider than ½ inch and longer than 3 feet, any evidence of soil particles entering structure through cracks, or maintenance person judges that structure is unsound.	Structure is sealed and structurally sound.
		Cracks wider than ½ inch and longer than 1 foot at the joint of any inlet/outlet pipe or any evidence of soil particles entering structure through cracks.	No cracks more than ¼ inch wide at the joint of inlet/outlet pipe.
	Settlement/misalignment	Structure has settled more than 1 inch or has rotated more than 2 inches out of alignment.	Basin replaced or repaired to design standards.
	Damaged pipe joints	Cracks wider than ½-inch at the joint of the inlet/outlet pipes or any evidence of soil entering the structure at the joint of the inlet/outlet pipes.	No cracks more than ¼-inch wide at the joint of inlet/outlet pipes.
	Contaminants and pollution	Any evidence of contaminants or pollution such as oil, gasoline, concrete slurries or paint.	Materials removed and disposed of according to applicable regulations. Source control BMPs implemented if appropriate. No contaminants present other than a surface oil film.
	Ladder rungs missing or unsafe	Ladder is unsafe due to missing rungs, misalignment, rust, cracks, or sharp edges.	Ladder meets design standards and allows maintenance person safe access.
FROP-T Section	Damage	T section is not securely attached to structure wall and outlet pipe structure should support at least 1,000 lbs of up or down pressure.	T section securely attached to wall and outlet pipe.
		Structure is not in upright position (allow up to 10% from plumb).	Structure in correct position.
		Connections to outlet pipe are not watertight or show signs of deteriorated grout.	Connections to outlet pipe are water tight; structure repaired or replaced and works as designed.
		Any holes—other than designed holes—in the structure.	Structure has no holes other than designed holes.
Cleanout Gate	Damaged or missing	Cleanout gate is missing.	Replace cleanout gate.

**Exhibit 13**  
**SSDP2016-00414**  
**000234**

<b>NO. 4 – CONTROL STRUCTURE/FLOW RESTRICTOR</b>			
<b>Maintenance Component</b>	<b>Defect or Problem</b>	<b>Condition When Maintenance is Needed</b>	<b>Results Expected When Maintenance is Performed</b>
		Cleanout gate is not watertight.	Gate is watertight and works as designed.
		Gate cannot be moved up and down by one maintenance person.	Gate moves up and down easily and is watertight.
		Chain/rod leading to gate is missing or damaged.	Chain is in place and works as designed.
Orifice Plate	Damaged or missing	Control device is not working properly due to missing, out of place, or bent orifice plate.	Plate is in place and works as designed.
	Obstructions	Any trash, debris, sediment, or vegetation blocking the plate.	Plate is free of all obstructions and works as designed.
Overflow Pipe	Obstructions	Any trash or debris blocking (or having the potential of blocking) the overflow pipe.	Pipe is free of all obstructions and works as designed.
	Deformed or damaged lip	Lip of overflow pipe is bent or deformed.	Overflow pipe does not allow overflow at an elevation lower than design
Inlet/Outlet Pipe	Sediment accumulation	Sediment filling 20% or more of the pipe.	Inlet/outlet pipes clear of sediment.
	Trash and debris	Trash and debris accumulated in inlet/outlet pipes (includes floatables and non-floatables).	No trash or debris in pipes.
	Damaged	Cracks wider than 1/2-inch at the joint of the inlet/outlet pipes or any evidence of soil entering at the joints of the inlet/outlet pipes.	No cracks more than 1/4-inch wide at the joint of the inlet/outlet pipe.
Metal Grates (If Applicable)	Unsafe grate opening	Grate with opening wider than 7/8 inch.	Grate opening meets design standards.
	Trash and debris	Trash and debris that is blocking more than 20% of grate surface.	Grate free of trash and debris. footnote to guidelines for disposal
	Damaged or missing	Grate missing or broken member(s) of the grate.	Grate is in place and meets design standards.
Manhole Cover/Lid	Cover/lid not in place	Cover/lid is missing or only partially in place. <b>Any open structure requires urgent maintenance.</b>	Cover/lid protects opening to structure.
	Locking mechanism Not Working	Mechanism cannot be opened by one maintenance person with proper tools. Bolts cannot be seated. Self-locking cover/lid does not work.	Mechanism opens with proper tools.
	Cover/lid difficult to Remove	One maintenance person cannot remove cover/lid after applying 80 lbs. of lift.	Cover/lid can be removed and reinstalled by one maintenance person.

**Exhibit 13**  
**SSDP2016-00414**  
**000235**

<b>NO. 5 – CATCH BASINS AND MANHOLES</b>			
<b>Maintenance Component</b>	<b>Defect or Problem</b>	<b>Condition When Maintenance is Needed</b>	<b>Results Expected When Maintenance is Performed</b>
Structure	Sediment	Sediment exceeds 60% of the depth from the bottom of the catch basin to the invert of the lowest pipe into or out of the catch basin or is within 6 inches of the invert of the lowest pipe into or out of the catch basin.	Sump of catch basin contains no sediment.
	Trash and debris	Trash or debris of more than ½ cubic foot which is located immediately in front of the catch basin opening or is blocking capacity of the catch basin by more than 10%.	No Trash or debris blocking or potentially blocking entrance to catch basin.
		Trash or debris in the catch basin that exceeds 1/3 the depth from the bottom of basin to invert the lowest pipe into or out of the basin.	No trash or debris in the catch basin.
		Dead animals or vegetation that could generate odors that could cause complaints or dangerous gases (e.g., methane).	No dead animals or vegetation present within catch basin.
		Deposits of garbage exceeding 1 cubic foot in volume.	No condition present which would attract or support the breeding of insects or rodents.
		Damage to frame and/or top slab	Corner of frame extends more than ¾ inch past curb face into the street (If applicable).
	Cracks in walls or bottom	Top slab has holes larger than 2 square inches or cracks wider than ¼ inch.	Top slab is free of holes and cracks.
		Frame not sitting flush on top slab, i.e., separation of more than ¾ inch of the frame from the top slab.	Frame is sitting flush on top slab.
		Cracks wider than ½ inch and longer than 3 feet, any evidence of soil particles entering catch basin through cracks, or maintenance person judges that catch basin is unsound.	Catch basin is sealed and structurally sound.
	Settlement/ misalignment	Cracks wider than ½ inch and longer than 1 foot at the joint of any inlet/outlet pipe or any evidence of soil particles entering catch basin through cracks.	No cracks more than 1/4 inch wide at the joint of inlet/outlet pipe.
		Catch basin has settled more than 1 inch or has rotated more than 2 inches out of alignment.	Basin replaced or repaired to design standards.
	Damaged pipe joints	Cracks wider than ½-inch at the joint of the inlet/outlet pipes or any evidence of soil entering the catch basin at the joint of the inlet/outlet pipes.	No cracks more than ¼-inch wide at the joint of inlet/outlet pipes.
	Contaminants and pollution	Any evidence of contaminants or pollution such as oil, gasoline, concrete slurries or paint.	Materials removed and disposed of according to applicable regulations. Source control BMPs implemented if appropriate. No contaminants present other than a surface oil film.
	Inlet/Outlet Pipe	Sediment accumulation	Sediment filling 20% or more of the pipe.
Trash and debris		Trash and debris accumulated in inlet/outlet pipes (includes floatables and non-floatables).	No trash or debris in pipes.
Damaged		Cracks wider than ½-inch at the joint of the inlet/outlet pipes or any evidence of soil entering at the joints of the inlet/outlet pipes.	No cracks more than ¼-inch wide at the joint of the inlet/outlet pipe.

**Exhibit 13**  
**SSDP2016-00414**  
**000236**

<b>NO. 5 – CATCH BASINS AND MANHOLES</b>			
<b>Maintenance Component</b>	<b>Defect or Problem</b>	<b>Condition When Maintenance is Needed</b>	<b>Results Expected When Maintenance is Performed</b>
Metal Grates (Catch Basins)	Unsafe grate opening	Grate with opening wider than $\frac{7}{8}$ inch.	Grate opening meets design standards.
	Trash and debris	Trash and debris that is blocking more than 20% of grate surface.	Grate free of trash and debris. footnote to guidelines for disposal
	Damaged or missing	Grate missing or broken member(s) of the grate. <b>Any open structure requires urgent maintenance.</b>	Grate is in place and meets design standards.
Manhole Cover/Lid	Cover/lid not in place	Cover/lid is missing or only partially in place. <b>Any open structure requires urgent maintenance.</b>	Cover/lid protects opening to structure.
	Locking mechanism Not Working	Mechanism cannot be opened by one maintenance person with proper tools. Bolts cannot be seated. Self-locking cover/lid does not work.	Mechanism opens with proper tools.
	Cover/lid difficult to Remove	One maintenance person cannot remove cover/lid after applying 80 lbs. of lift.	Cover/lid can be removed and reinstalled by one maintenance person.

**Exhibit 13**  
**SSDP2016-00414**  
**000237**

<b>NO. 6 – CONVEYANCE PIPES AND DITCHES</b>			
<b>Maintenance Component</b>	<b>Defect or Problem</b>	<b>Conditions When Maintenance is Needed</b>	<b>Results Expected When Maintenance is Performed</b>
Pipes	Sediment & debris accumulation	Accumulated sediment or debris that exceeds 20% of the diameter of the pipe.	Water flows freely through pipes.
	Vegetation/roots	Vegetation/roots that reduce free movement of water through pipes.	Water flows freely through pipes.
	Contaminants and pollution	Any evidence of contaminants or pollution such as oil, gasoline, concrete slurries or paint.	Materials removed and disposed of according to applicable regulations. Source control BMPs implemented if appropriate. No contaminants present other than a surface oil film.
	Damage to protective coating or corrosion	Protective coating is damaged; rust or corrosion is weakening the structural integrity of any part of pipe.	Pipe repaired or replaced.
	Damaged	Any dent that decreases the cross section area of pipe by more than 20% or is determined to have weakened structural integrity of the pipe.	Pipe repaired or replaced.
Ditches	Trash and debris	Trash and debris exceeds 1 cubic foot per 1,000 square feet of ditch and slopes.	Trash and debris cleared from ditches.
	Sediment accumulation	Accumulated sediment that exceeds 20% of the design depth.	Ditch cleaned/flushed of all sediment and debris so that it matches design.
	Noxious weeds	Any noxious or nuisance vegetation which may constitute a hazard to County personnel or the public.	Noxious and nuisance vegetation removed according to applicable regulations. No danger of noxious vegetation where County personnel or the public might normally be.
	Contaminants and pollution	Any evidence of contaminants or pollution such as oil, gasoline, concrete slurries or paint.	Materials removed and disposed of according to applicable regulations. Source control BMPs implemented if appropriate. No contaminants present other than a surface oil film.
	Vegetation	Vegetation that reduces free movement of water through ditches.	Water flows freely through ditches.
	Erosion damage to slopes	Any erosion observed on a ditch slope.	Slopes are not eroding.
	Rock lining out of place or missing (If Applicable)	One layer or less of rock exists above native soil area 5 square feet or more, any exposed native soil.	Replace rocks to design standards.

**Exhibit 13**  
**SSDP2016-00414**  
**000238**