

# East Lake Sammamish Master Plan Trail – South Sammamish Segment B Draft Technical Information Report

Prepared for  
**King County**  
Division of Capital Planning and Development  
Facilities Management Division, DES



October 2016

Prepared by  
**Parametrix**





# East Lake Sammamish Master Plan Trail - South Sammamish Segment B Draft Technical Information Report

*Prepared for*

**King County**

Division of Capital Planning and Development  
Facilities Management Division, DES  
201 S Jackson Street , Suite 700  
Seattle, WA 98104

*Prepared by*

**Parametrix**

719 2nd Avenue, Suite 200  
Seattle, WA 98104  
T. 206.394.3700 F. 1.855.542.6353  
[www.parametrix.com](http://www.parametrix.com)

## CITATION

Parametrix. 2016. East Lake Sammamish Master Plan Trail -  
South Sammamish Segment B  
Draft Technical Information Report. Prepared by Parametrix,  
Seattle, WA. October 2016.

## CERTIFICATION

The technical material and data contained in this document were prepared under the supervision and direction of the undersigned, whose seal, as a professional engineer licensed to practice as such, is affixed below.

---

Prepared by Craig Buitrago, P.E.



# TABLE OF CONTENTS

- 1. PROJECT OVERVIEW ..... 1-1**
  - 1.1 Project Description ..... 1-1
  - 1.2 Existing Site Conditions ..... 1-1
  - 1.3 Project Area Soils ..... 1-55
  - 1.4 Groundwater ..... 1-61
- 2. CONDITIONS AND REQUIREMENTS ..... 2-1**
  - 2.1 Flow Control BMP Requirements ..... 2-2
- 3. OFFSITE ANALYSIS ..... 3-1**
  - 3.1 Study Area Definition and Maps ..... 3-1
  - 3.2 Resource Review ..... 3-1
    - 3.2.2 Water Quality Problems Requiring Special Attention ..... 3-2
  - 3.3 Field Inspection ..... 3-2
  - 3.4 Drainage System and Problem Descriptions ..... 3-21
  - 3.5 Mitigation of Existing or Potential Problems ..... 3-24
- 4. FLOW CONTROL AND WATER QUALITY FACILITY ANALYSIS AND DESIGN ..... 4-1**
  - 4.1 Existing Site Hydrology ..... 4-1
    - 4.1.1 Existing (Pre-developed) Land Use ..... 4-1
  - 4.2 Developed Site Hydrology ..... 4-1
    - 4.2.1 Developed Land Use ..... 4-1
    - 4.2.2 Developed Drainage and Flow Characteristics ..... 4-4
  - 4.3 Performance Standards ..... 4-5
  - 4.4 Flow Control System ..... 4-6
  - 4.5 Water Quality System ..... 4-9
- 5. CONVEYANCE SYSTEM ANALYSIS AND DESIGN ..... 5-1**
  - 5.1 Culverts ..... 5-1
  - 5.2 Fish Passage Mitigation ..... 5-3
  - 5.3 Ditches ..... 5-7
  - 5.4 Underdrain conveyance systems ..... 5-8
  - 5.5 Conveyance pipes ..... 5-9

## TABLE OF CONTENTS (CONTINUED)

<b>6.</b>	<b>SPECIAL REPORTS AND STUDIES.....</b>	<b>6-1</b>
<b>7.</b>	<b>OTHER PERMITS .....</b>	<b>7-1</b>
<b>8.</b>	<b>TESC DESIGN.....</b>	<b>8-1</b>
<b>9.</b>	<b>BOND QUANTITIES, FACILITY SUMMARIES, AND DECLARATION OF COVENANT .....</b>	<b>9-1</b>
<b>10.</b>	<b>OPERATION AND MAINTENANCE.....</b>	<b>10-1</b>
10.1	Stormwater Management.....	10-1
10.2	Vegetation Management.....	10-1
<b>11.</b>	<b>REFERENCES .....</b>	<b>11-1</b>

### LIST OF FIGURES

1-1	TIR Worksheet.....	1-3
1-2	Site Location Map .....	1-51
1-3	Drainage Basins, Subbasins, and Site Characteristics .....	1-53
1-4	Soils .....	1-57
1-5	Geologic Hazards .....	1-59
3-1	Threshold Discharge Areas 10, 12, and 13.....	3-3
3-2	Threshold Discharge Areas 14 through 21.....	3-5
3-3	Threshold Discharge Areas 22 through 28.....	3-7
3-4	Threshold Discharge Areas 29 through 33.....	3-9
3-5	Threshold Discharge Areas 34 through 39.....	3-11
3-6	Threshold Discharge Areas 40 through 47.....	3-13
3-7	Threshold Discharge Areas 48 through 53.....	3-15
3-8	Threshold Discharge Areas 54 through 58.....	3-17
3-9	Threshold Discharge Areas 59 through 63.....	3-19

### LIST OF TABLES

1-2	Project Area Soils .....	1-55
2-1	Summary of Project Area Impervious Surfaces .....	2-1
2-2	Summary of Core and Special Requirements .....	2-1
2-3	Summary of Credit Requirement for Flow Control BMP .....	2-3
4-1	Land Use Summary .....	4-2
4-2	Flow Control Facility Exemption Summary .....	4-6
4-6	Proposed New plus Replaced PGIS Summary.....	4-9
5-1	Summary of Existing Culverts and Proposed Action.....	5-2
5-2	Summary of Affected Ditches and Proposed Design .....	5-7

## TABLE OF CONTENTS (CONTINUED)

### APPENDICES

- A Drainage Plans, Profiles, and Detail Sheets
- B Offsite Analysis Descriptions, Drainage Problems and Complaints
- C Hydrologic and Hydraulic Calculations
  - C1 – Detailed Land Use
  - C2 – WWHM2012 Outputs
  - C3 – Hydraulic Calculations for Stream Culverts
  - C4 – Conveyance Calculations
- D Fish Passage Communications with Muckleshoot Indian Tribe
- E Operation and Maintenance Requirements

DRAFT





## ACRONYMS

ADS	Advanced Drainage Systems
BMP	best management practice
BNSF	Burlington Northern Santa Fe
CARA	Critical Aquifer Recharge Area
cfs	cubic feet per second
CMP	corrugated metal pipe
DO	dissolved oxygen
Ecology	Washington State Department of Ecology
ELSP	East Lake Sammamish Parkway
ELST	East Lake Sammamish Trail
HDPE	high density polyethylene
2009 Manual	King County Surface Water Design Manual of 2009
Master Plan Trail	East Lake Sammamish Master Plan Trail
MGSFloodV4	MGSFlood Version 4
NPDES	National Pollutant Discharge Elimination System
NRCS	Natural Resources Conservation Service
O&M	operation and maintenance
PGIS	pollution-generating impervious surfaces
Q100	100-year peak flow rate
Sta.	station
TDA	threshold discharge area
TESC	temporary erosion and sediment control
TIR	technical information report
TMDL	total maximum daily load
WDFW	Washington Department of Fish and Wildlife
WWHM4	Western Washington Hydrology Model version 4
WRIA	Water Resource Inventory Area



# 1. PROJECT OVERVIEW

## 1.1 Project Description

The East Lake Sammamish Master Plan Trail (Master Plan Trail) Project begins at Gilman Boulevard in Issaquah and ends 200 feet south of Bear Creek in Redmond. The East Lake Sammamish Trail (ELST) is located on the alignment of the former Burlington Northern Santa Fe (BNSF) railroad that began operations in 1855 and ceased operations along this corridor in 1996. King County acquired the rail-banked corridor in 1998 and completed construction of an interim trail in 2006. The ELST corridor is approximately 11 miles and travels along the east shore of Lake Sammamish. Proposed improvements will be constructed in multiple phases, which correspond with the three jurisdictions the trail crosses—Redmond, Sammamish, and Issaquah.

The Redmond Section of the trail was constructed in 2011 and the Issaquah Section was constructed in 2013. The North Sammamish Section is scheduled for construction in 2014. The entire 4.8-mile South Sammamish Section of the ELST is separated into two construction phases: Segments A and B. Segment A is approximately 1.3 miles long from the city of Issaquah boundary at the south end to SE 33rd Street at the north terminus. Segment B is approximately 3.5 miles long from SE 33rd Street at the south end to the Inglewood Hill Road Parking Lot at the north terminus.

This technical information report (TIR) provides stormwater design documentation for the South Sammamish Segment B phase of the Master Plan Trail project. The TIR Worksheet (Figure 1-1) provides a general overview of the components of this report. Appendices A through E provide drainage design plans, downstream analysis, publicly recorded drainage complaints and site specific drainage problem investigations, detailed land use and drainage design calculations (hydrologic and hydraulic), communications with Muckleshoot Indian Tribe regarding fish passage culvert replacements, an operation and maintenance requirements to supplement the discussions in this report.

The East Lake Sammamish Trail – South Sammamish Segment B project will redevelop approximately 3.5 miles of the trail from SE 33rd Street at the south end to Inglewood Hill Road Parking Lot at the north terminus. The project includes widening and paving the existing gravel trail, conducting safety and accessibility improvements, providing storm drainage improvements, and implementing culvert replacements to improve fish passage. Trail improvements include increasing the width of the existing 8- to 12-foot-wide gravel trail to 12 feet of asphalt with 2- or 3-foot-wide gravel shoulders on both sides. This work will disturb approximately 9.5 acres. A site location map is provided as Figure 1-2.

The Master Plan Trail alignment and profile has been adjusted, and walls have been designed to minimize impacts on streams, wetlands, and stormwater ditches, as well as to preserve the wetland and stream habitat and functions.

## 1.2 Existing Site Conditions

The ELST is an 8- to 12-foot-wide gravel trail located on a historical railroad prism that generally runs along the east side of Lake Sammamish. Lake Sammamish is located within one-quarter mile downstream of the trail, throughout the South Sammamish Segment B. The project corridor crosses several of the East Lake Sammamish Drainage Basins including Monohon, Pine Lake Creek, Thompson, Inglewood, and the southern tip of the Panhandle (Figure 1-3). East Lake Sammamish Parkway (ELSP) parallels the trail to the east for most of the trail length.

Trail runoff sheet flows to adjacent streams, ditches, wetlands, or private property. Existing ditches and wetlands convey runoff to the streams, which flow from northeast to southwest beneath the trail to Lake Sammamish.

Project TDAs are delineated in three ways: areas that runoff directly to the lake via overland flow or manmade conveyance, areas that runoff directly to streams that cross the trail and flow into Lake Sammamish, and areas that runoff to adjacent private property landscaping. Fifty-three TDAs were identified within the project. These TDAs are discussed and depicted in Chapter 3 Offsite Analysis.

Tributaries in the four subbasins within the project vicinity are shown on Figure 1-3. Seventeen streams cross the trail as depicted in Figure 1-3: Pine Lake Creek, Ebright Creek, Zaccuse Creek, George Davis Creek, Stream 0155, Stream 0143 South Fork and North Fork, and Unnamed Streams 4 through 13. Most of the streams flow from east to west through the trail corridor and cross beneath the trail prior to flowing to Lake Sammamish. Unnamed Stream 8 and Stream 0143L both enter the project area as one stream, and diverge into a south and north forks that cross beneath the trail at different locations. Further discussion about TDAs is provided in Chapter 3 Offsite Analysis.

**TECHNICAL INFORMATION REPORT (TIR) WORKSHEET**

**PART 1 PROJECT OWNER AND PROJECT ENGINEER**

Project Owner King County Parks

Phone 206-263-7281

Address 201 S. Jackson, 7<sup>th</sup> Floor  
Seattle, WA 98104

Project Engineer Craig Buitrago, PE

Company Parametrix

Phone 206-394-3700

**PART 2 PROJECT LOCATION AND DESCRIPTION**

Project Name East Lake Sammamish  
Master Plan Trail, South Sammamish Segment A -  
Issaquah/Sammamish City Limit to SE 33<sup>rd</sup> Street

DPER Permit # \_\_\_\_\_

Location Township 24

Range 06

Section 08, 17

Site Address N/A, King County  
right-of-way

**PART 3 TYPE OF PERMIT APPLICATION**

- Landuse Services
- Subdivision/Short Subd. / UPD
- Building Services
- M/F / Commercial / SFR
- Clearing and Grading
- Right-of-Way Use
- Other \_\_\_\_\_

**PART 4 OTHER REVIEWS AND PERMITS**

- DFW HPA
- COE 404
- DOE Dam Safety
- FEMA Floodplain
- COE Wetlands
- Other \_\_\_\_\_
- Shoreline Mgmt
- Structural
- Rockery/Vault/
- ESA Section 7

**PART 5 PLAN AND REPORT INFORMATION**

**Technical Information Report**

Type of Drainage Review:  Full/  Targeted  
 Large Site

Date (include revision dates): \_\_\_\_\_

Date of Final \_\_\_\_\_

**Site Improvement Plan (Engr. Plans)**

Type:  Full/  Targeted  
 Large Site

Date (include revision dates): \_\_\_\_\_

Date of Final \_\_\_\_\_

**PART 6 ADJUSTMENT APPROVALS**

Type:  Standard  Complex  Preapplication  Experimental  Blanket

Description: (include conditions in TIR Section 2)

The project will apply for a drainage adjustment to Core Requirement 2, which requires the project to maintain natural discharge locations from a project site. The adjustment is necessary to combine the existing direct discharge outfall locations to one new direct discharge outfall location.

Date of Approval: \_\_\_\_\_

**TECHNICAL INFORMATION REPORT (TIR) WORKSHEET**

**PART 7 MONITORING REQUIREMENTS**

Monitoring Required	<input type="checkbox"/> Yes <input checked="" type="checkbox"/> No	Describe <div style="border: 1px solid black; height: 60px; width: 100%;"></div>
Start Date:	_____	
Completion Date:	_____	

**PART 8 SITE COMMUNITY AND DRAINAGE BASIN**

Community Plan:	_____
Special District Overlays:	_____
Drainage Basin:	East Lake Sammamish, Panhandle, Inglewood, Monohom, Thompson, Pine Lake Creek
Stormwater Requirements:	2009 King County Surface Water Design Manual and 2011 City of Sammamish Surface Water Design Manual Addendum

**PART 9 ONSITE AND ADJACENT SENSITIVE AREAS**

<input checked="" type="checkbox"/> River/Stream  <input checked="" type="checkbox"/> Lake  <input checked="" type="checkbox"/> Wetlands <input type="checkbox"/> Closed Depression <input checked="" type="checkbox"/> Floodplain <input type="checkbox"/> Other	Unnamed Stream #4, Unnamed Stream #5, Unnamed Stream #6, Unnamed Stream #7, Pine Lake Creek, Unnamed Stream #8, Zaccuse Creek, Unnamed Stream #9, George Davis Creek, Unnamed Stream #10, Unnamed Stream #11, Unnamed Stream #12, Unnamed Stream #13, Stream 014L <hr/> Lake Sammamish 15A, 15BC, 15D, 15E, 18C, 19A, 19B, 20A, 21b, 21AC, 21D, 22AB, 22CD, 23A, 23B, 23C, 24A, 24B, 24C, 25A, 25B, 25C, 25F, 26A, 26B, 26C, 28C, 28D, 29B, 29C, 29D, 30B <hr/> Lake Sammamish _____	<input checked="" type="checkbox"/> Steep Slope <input checked="" type="checkbox"/> Erosion Hazard  <input checked="" type="checkbox"/> Landslide Hazard <input type="checkbox"/> Coal Mine Hazard <input checked="" type="checkbox"/> Seismic Hazard <input type="checkbox"/> Habitat Protection
--	--	---

**TECHNICAL INFORMATION REPORT (TIR) WORKSHEET**

**PART 10 SOILS**

Soil Type	Slopes	Erosion Potential
AgC	5 - 15%	Moderate
AgD	15 - 30%	Severe
<b>AkF</b>	<b>F</b>	
EvC	5 - 15%	Moderate
EvD	15 - 30%	Severe
KpB	<2 - 8%	Slight to Moderate
KpC	5 - 15%	Moderate
<b>Ma</b>	<b>A</b>	
No	15 - 30%	Severe
Sk	15 - 30%	Severe

High Groundwater Table (within 5 feet)
  Sole Source Aquifer  
 Other \_\_\_\_\_
  Seeps/Springs  
 Additional Sheets Attached

**PART 11 DRAINAGE DESIGN LIMITATIONS**

REFERENCE	LIMITATION / SITE CONSTRAINT
<input checked="" type="checkbox"/> Core 2 - Offsite Analysis	Private properties downstream
<input checked="" type="checkbox"/> Sensitive/ Critical Areas	Wetland Impact Mitigation
<input type="checkbox"/> SEPA	
<input type="checkbox"/> Other	
<input type="checkbox"/>	
<input type="checkbox"/> Additional Sheets Attached	

**PART 12 TIR SUMMARY SHEET (PROVIDE ONE TIR SUMMARY SHEET PER THRESHOLD DISCHARGE AREA)**

**Threshold Discharge Area**  
 (name or description): TDA 10: Station 283+25 to 287+78

**Core Requirements (all 8 apply)**

Discharge at Natural Location      Number of Natural Discharge Locations: 1

Offsite Analysis:      Level:  1    2    3      Dated: 4/16/2013 and 4/24/2013

Flow Control  
 (incl. facility summary sheet)      Level:  1    2    3      or Exemption Number Q<sub>100</sub> increase < 0.1 cfs  
 Small Site BMPs N/A

Conveyance System      Spill containment located at: N/A

Erosion and Sediment Control      ESC Site Supervisor: Craig Buitrago  
 Contact Phone: 206-394-3700  
 After Hours Phone: 206-394-3700

Maintenance and Operation      Responsibility:  Private    Public  
 If Private, Maintenance Log Required:  Yes    No

**TECHNICAL INFORMATION REPORT (TIR) WORKSHEET**

Financial Guarantees and Liability Provided:  Yes  No

Water Quality (include facility summary sheet) Type:  Basic  Sens. Lake  Enhanced Basic  Bog  
Or Exemption No. 1, Surface Area Exemption  
Landscape Management Plan:  Yes  No

**Special Requirements (as applicable)**

Area Specific Drainage Requirements Type:  CDA  SDO  MDP  BP  Shared Fac.  None  
Name:

Floodplain/Floodway Delineation Type:  Major  Minor  Exemption  None  
100- year Base Flood Elevation (or range): 36.57  
Datum: NAVD 88

Flood Protection Facilities Describe: N/A

Source Control (comm./ industrial landuse) Describe: N/A  
Describe any structural controls: N/A

Oil Control High-use Site:  Yes  No  
Treatment BMP: N/A  
Maintenance Agreement:  Yes  No  
With whom? N/A

**Other Drainage Structures**

Describe:

**Threshold Discharge Area**

(name or description): TDA 11: Station 287+25 to 295+85

**Core Requirements (all 8 apply)**

Discharge at Natural Location Number of Natural Discharge Locations: 1

Offsite Analysis: Level:  1  2  3 Dated: 4/16/2013 and 4/24/2013

Flow Control (incl. facility summary sheet) Level:  1  2  3 or Exemption Number Q<sub>100</sub> increase < 0.1 cfs  
Small Site BMPs N/A

Conveyance System Spill containment located at: N/A

Erosion and Sediment Control ESC Site Supervisor: Craig Buitrago  
Contact Phone: 206-394-3700  
After Hours Phone: 206-394-3700

Maintenance and Operation Responsibility:  Private  Public  
If Private, Maintenance Log Required:  Yes  No

Financial Guarantees and Liability Provided:  Yes  No

Water Quality (include facility summary sheet) Type:  Basic  Sens. Lake  Enhanced Basic  Bog  
Or Exemption No. 1, Surface Area Exemption  
Landscape Management Plan:  Yes  No

**Special Requirements (as applicable)**

Area Specific Drainage Requirements Type:  CDA  SDO  MDP  BP  Shared Fac.  None  
Name:

Floodplain/Floodway Delineation Type:  Major  Minor  Exemption  None  
100- year Base Flood Elevation (or range): 36.57  
Datum: NAVD 88

Flood Protection Facilities Describe: N/A



**TECHNICAL INFORMATION REPORT (TIR) WORKSHEET**

Source Control (comm./ industrial landuse)	Describe: N/A Describe any structural controls: N/A
Oil Control	High-use Site: <input type="checkbox"/> Yes <input checked="" type="checkbox"/> No Treatment BMP: N/A Maintenance Agreement: <input type="checkbox"/> Yes <input checked="" type="checkbox"/> No With whom? N/A

**Other Drainage Structures**

Describe: 2-ft wide by 2-ft deep infiltration trenches will be installed in the gravel shoulder of the trail from STA 288+00 to 288+75. The infiltration trenches will provide full infiltration to satisfy the flow control requirement. Infiltration trench location and details provided on plans sheets provided in Appendix A and MGSFlood performance calculation provided in Appendix C

**Threshold Discharge Area**

(name or description): **TDA 12: Station 295+85 to 300+25**

**Core Requirements (all 8 apply)**

Discharge at Natural Location	Number of Natural Discharge Locations: 1
Offsite Analysis:	Level: <input checked="" type="checkbox"/> 1 <input type="checkbox"/> 2 <input type="checkbox"/> 3      Dated: 4/16/2013 and 4/24/2013
Flow Control (incl. facility summary sheet)	Level: <input type="checkbox"/> 1 <input type="checkbox"/> 2 <input type="checkbox"/> 3      or Exemption Number <u>Q<sub>100</sub> increase &lt; 0.1 cfs</u> Small Site BMPs N/A
Conveyance System	Spill containment located at: N/A
Erosion and Sediment Control	ESC Site Supervisor: Craig Buitrago Contact Phone: 206-394-3700 After Hours Phone: 206-394-3700
Maintenance and Operation	Responsibility: <input type="checkbox"/> Private <input checked="" type="checkbox"/> Public If Private, Maintenance Log Required: <input type="checkbox"/> Yes <input type="checkbox"/> No
Financial Guarantees and Liability	Provided: <input type="checkbox"/> Yes <input checked="" type="checkbox"/> No
Water Quality (include facility summary sheet)	Type: <input type="checkbox"/> Basic <input type="checkbox"/> Sens. Lake <input type="checkbox"/> Enhanced Basic <input type="checkbox"/> Bog Or Exemption No. 1, Surface Area Exemption Landscape Management Plan: <input checked="" type="checkbox"/> Yes <input type="checkbox"/> No

**Special Requirements (as applicable)**

Area Specific Drainage Requirements	Type: <input type="checkbox"/> CDA <input type="checkbox"/> SDO <input type="checkbox"/> MDP <input type="checkbox"/> BP <input type="checkbox"/> Shared Fac. <input checked="" type="checkbox"/> None Name:
Floodplain/Floodway Delineation	Type: <input type="checkbox"/> Major <input type="checkbox"/> Minor <input checked="" type="checkbox"/> Exemption <input type="checkbox"/> None 100- year Base Flood Elevation (or range): 36.57 Datum: NAVD 88
Flood Protection Facilities	Describe: N/A
Source Control (comm./ industrial landuse)	Describe: N/A Describe any structural controls: N/A
Oil Control	High-use Site: <input type="checkbox"/> Yes <input checked="" type="checkbox"/> No Treatment BMP: N/A Maintenance Agreement: <input type="checkbox"/> Yes <input checked="" type="checkbox"/> No With whom? N/A

**Other Drainage Structures**

Describe:

**Threshold Discharge Area**      TDA 13: Station 300+25 to 304+65

**TECHNICAL INFORMATION REPORT (TIR) WORKSHEET**

(name or description):

**Core Requirements (all 8 apply)**

Discharge at Natural Location	Number of Natural Discharge Locations: 1
Offsite Analysis:	Level: <input checked="" type="checkbox"/> 1 <input type="checkbox"/> 2 <input type="checkbox"/> 3 Dated: 4/16/2013 and 4/24/2013
Flow Control (incl. facility summary sheet)	Level: <input type="checkbox"/> 1 <input type="checkbox"/> 2 <input type="checkbox"/> 3 or Exemption Number <u>Q<sub>100</sub> increase &lt; 0.1 cfs</u> Small Site BMPs N/A
Conveyance System	Spill containment located at: N/A
Erosion and Sediment Control	ESC Site Supervisor: Craig Buitrago Contact Phone: 206-394-3700 After Hours Phone: 206-394-3700
Maintenance and Operation	Responsibility: <input type="checkbox"/> Private <input checked="" type="checkbox"/> Public If Private, Maintenance Log Required: <input type="checkbox"/> Yes <input type="checkbox"/> No
Financial Guarantees and Liability	Provided: <input type="checkbox"/> Yes <input checked="" type="checkbox"/> No
Water Quality (include facility summary sheet)	Type: <input type="checkbox"/> Basic <input type="checkbox"/> Sens. Lake <input type="checkbox"/> Enhanced Basic <input type="checkbox"/> Bog Or Exemption No. 1, Surface Area Exemption Landscape Management Plan: <input checked="" type="checkbox"/> Yes <input type="checkbox"/> No

**Special Requirements (as applicable)**

Area Specific Drainage Requirements	Type: <input type="checkbox"/> CDA <input type="checkbox"/> SDO <input type="checkbox"/> MDP <input type="checkbox"/> BP <input type="checkbox"/> Shared Fac. <input checked="" type="checkbox"/> None Name:
Floodplain/Floodway Delineation	Type: <input type="checkbox"/> Major <input type="checkbox"/> Minor <input checked="" type="checkbox"/> Exemption <input type="checkbox"/> None 100- year Base Flood Elevation (or range): 36.57 Datum: NAVD 88
Flood Protection Facilities	Describe: N/A
Source Control (comm./ industrial landuse)	Describe: N/A Describe any structural controls: N/A
Oil Control	High-use Site: <input type="checkbox"/> Yes <input checked="" type="checkbox"/> No Treatment BMP: N/A Maintenance Agreement: <input type="checkbox"/> Yes <input checked="" type="checkbox"/> No With whom? N/A

**Other Drainage Structures**

Describe:

**Threshold Discharge Area**

(name or description): TDA 14: Station 304+65 to 308+25

**Core Requirements (all 8 apply)**

Discharge at Natural Location	Number of Natural Discharge Locations: 1
Offsite Analysis:	Level: <input checked="" type="checkbox"/> 1 <input type="checkbox"/> 2 <input type="checkbox"/> 3 Dated: 4/16/2013 and 4/24/2013
Flow Control (incl. facility summary sheet)	Level: <input type="checkbox"/> 1 <input type="checkbox"/> 2 <input type="checkbox"/> 3 or Exemption Number <u>Q<sub>100</sub> increase &lt; 0.1 cfs</u> Small Site BMPs N/A
Conveyance System	Spill containment located at: N/A
Erosion and Sediment Control	ESC Site Supervisor: Craig Buitrago Contact Phone: 206-394-3700 After Hours Phone: 206-394-3700
Maintenance and Operation	Responsibility: <input type="checkbox"/> Private <input checked="" type="checkbox"/> Public

**TECHNICAL INFORMATION REPORT (TIR) WORKSHEET**

If Private, Maintenance Log Required:  Yes  No

Financial Guarantees and Liability  
 Provided:  Yes  No

Water Quality (include facility summary sheet)  
 Type:  Basic  Sens. Lake  Enhanced Basic  Bog  
 Or Exemption No. 1, Surface Area Exemption  
 Landscape Management Plan:  Yes  No

**Special Requirements (as applicable)**

Area Specific Drainage Requirements  
 Type:  CDA  SDO  MDP  BP  Shared Fac.  None  
 Name:

Floodplain/Floodway Delineation  
 Type:  Major  Minor  Exemption  None  
 100- year Base Flood Elevation (or range): 36.57  
 Datum: NAVD 88

Flood Protection Facilities Describe: N/A

Source Control (comm./ industrial landuse)  
 Describe: N/A  
 Describe any structural controls: N/A

Oil Control  
 High-use Site:  Yes  No  
 Treatment BMP: N/A  
 Maintenance Agreement:  Yes  No  
 With whom? N/A

**Other Drainage Structures**

Describe:

**Threshold Discharge Area**

(name or description): TDA 15: Station 308+25 to 209+25

**Core Requirements (all 8 apply)**

Discharge at Natural Location Number of Natural Discharge Locations: 1

Offsite Analysis: Level:  1  2  3 Dated: 4/16/2013 and 4/24/2013

Flow Control (incl. facility summary sheet)  
 Level:  1  2  3 or Exemption Number  $Q_{100}$  increase  $< 0.1$  cfs  
 Small Site BMPs N/A

Conveyance System Spill containment located at: N/A

Erosion and Sediment Control  
 ESC Site Supervisor: Craig Buitrago  
 Contact Phone: 206-394-3700  
 After Hours Phone: 206-394-3700

Maintenance and Operation  
 Responsibility:  Private  Public  
 If Private, Maintenance Log Required:  Yes  No

Financial Guarantees and Liability  
 Provided:  Yes  No

Water Quality (include facility summary sheet)  
 Type:  Basic  Sens. Lake  Enhanced Basic  Bog  
 Or Exemption No. 1, Surface Area Exemption  
 Landscape Management Plan:  Yes  No

**Special Requirements (as applicable)**

Area Specific Drainage Requirements  
 Type:  CDA  SDO  MDP  BP  Shared Fac.  None  
 Name:

Floodplain/Floodway Delineation  
 Type:  Major  Minor  Exemption  None  
 100- year Base Flood Elevation (or range): 36.57  
 Datum: NAVD 88

**TECHNICAL INFORMATION REPORT (TIR) WORKSHEET**

Flood Protection Facilities	Describe: N/A
Source Control (comm./ industrial landuse)	Describe: N/A Describe any structural controls: N/A
Oil Control	High-use Site: <input type="checkbox"/> Yes <input checked="" type="checkbox"/> No Treatment BMP: N/A Maintenance Agreement: <input type="checkbox"/> Yes <input checked="" type="checkbox"/> No With whom? N/A

**Other Drainage Structures**

Describe:

**Threshold Discharge Area**

(name or description): TDA 16: Station 309+25 to 311+00

**Core Requirements (all 8 apply)**

Discharge at Natural Location	Number of Natural Discharge Locations: 1
Offsite Analysis:	Level: <input checked="" type="checkbox"/> 1 <input type="checkbox"/> 2 <input type="checkbox"/> 3 Dated: 4/16/2013 and 4/24/2013
Flow Control (incl. facility summary sheet)	Level: <input type="checkbox"/> 1 <input type="checkbox"/> 2 <input type="checkbox"/> 3 or Exemption Number <u>Q<sub>100</sub> increase &lt; 0.1 cfs</u> Small Site BMPs N/A
Conveyance System	Spill containment located at: N/A
Erosion and Sediment Control	ESC Site Supervisor: Craig Buitrago Contact Phone: 206-394-3700 After Hours Phone: 206-394-3700
Maintenance and Operation	Responsibility: <input type="checkbox"/> Private <input checked="" type="checkbox"/> Public If Private, Maintenance Log Required: <input type="checkbox"/> Yes <input type="checkbox"/> No
Financial Guarantees and Liability	Provided: <input type="checkbox"/> Yes <input checked="" type="checkbox"/> No
Water Quality (include facility summary sheet)	Type: <input type="checkbox"/> Basic <input type="checkbox"/> Sens. Lake <input type="checkbox"/> Enhanced Basic <input type="checkbox"/> Bog Or Exemption No. 1, Surface Area Exemption Landscape Management Plan: <input checked="" type="checkbox"/> Yes <input type="checkbox"/> No

**Special Requirements (as applicable)**

Area Specific Drainage Requirements	Type: <input type="checkbox"/> CDA <input type="checkbox"/> SDO <input type="checkbox"/> MDP <input type="checkbox"/> BP <input type="checkbox"/> Shared Fac. <input checked="" type="checkbox"/> None Name:
Floodplain/Floodway Delineation	Type: <input type="checkbox"/> Major <input type="checkbox"/> Minor <input checked="" type="checkbox"/> Exemption <input type="checkbox"/> None 100- year Base Flood Elevation (or range): 36.57 Datum: NAVD 88
Flood Protection Facilities	Describe: N/A
Source Control (comm./ industrial landuse)	Describe: N/A Describe any structural controls: N/A
Oil Control	High-use Site: <input type="checkbox"/> Yes <input checked="" type="checkbox"/> No Treatment BMP: N/A Maintenance Agreement: <input type="checkbox"/> Yes <input checked="" type="checkbox"/> No With whom? N/A

**Other Drainage Structures**

Describe:

**TECHNICAL INFORMATION REPORT (TIR) WORKSHEET**

**Threshold Discharge Area**

(name or description): TDA 17: Station 311+00 to 312+90

**Core Requirements (all 8 apply)**

Discharge at Natural Location	Number of Natural Discharge Locations: 1
Offsite Analysis:	Level: <input checked="" type="checkbox"/> 1 <input type="checkbox"/> 2 <input type="checkbox"/> 3 Dated: 4/16/2013 and 4/24/2013
Flow Control (incl. facility summary sheet)	Level: <input type="checkbox"/> 1 <input type="checkbox"/> 2 <input type="checkbox"/> 3 or Exemption Number <u>Q<sub>100</sub> increase &lt; 0.1 cfs</u> Small Site BMPs N/A
Conveyance System	Spill containment located at: N/A
Erosion and Sediment Control	ESC Site Supervisor: Craig Buitrago Contact Phone: 206-394-3700 After Hours Phone: 206-394-3700
Maintenance and Operation	Responsibility: <input type="checkbox"/> Private <input checked="" type="checkbox"/> Public If Private, Maintenance Log Required: <input type="checkbox"/> Yes <input type="checkbox"/> No
Financial Guarantees and Liability	Provided: <input type="checkbox"/> Yes <input checked="" type="checkbox"/> No
Water Quality (include facility summary sheet)	Type: <input type="checkbox"/> Basic <input type="checkbox"/> Sens. Lake <input type="checkbox"/> Enhanced Basic <input type="checkbox"/> Bog Or Exemption No. 1, Surface Area Exemption Landscape Management Plan: <input checked="" type="checkbox"/> Yes <input type="checkbox"/> No

**Special Requirements (as applicable)**

Area Specific Drainage Requirements	Type: <input type="checkbox"/> CDA <input type="checkbox"/> SDO <input type="checkbox"/> MDP <input type="checkbox"/> BP <input type="checkbox"/> Shared Fac. <input checked="" type="checkbox"/> None Name:
Floodplain/Floodway Delineation	Type: <input type="checkbox"/> Major <input type="checkbox"/> Minor <input checked="" type="checkbox"/> Exemption <input type="checkbox"/> None 100- year Base Flood Elevation (or range): 36.57 Datum: NAVD 88
Flood Protection Facilities	Describe: N/A
Source Control (comm./ industrial landuse)	Describe: N/A Describe any structural controls: N/A
Oil Control	High-use Site: <input type="checkbox"/> Yes <input checked="" type="checkbox"/> No Treatment BMP: N/A Maintenance Agreement: <input type="checkbox"/> Yes <input checked="" type="checkbox"/> No With whom? N/A

**Other Drainage Structures**

Describe:

**Threshold Discharge Area**

(name or description): TDA 18: Station 312+90 to 314+00

**Core Requirements (all 8 apply)**

Discharge at Natural Location	Number of Natural Discharge Locations: 1
Offsite Analysis:	Level: <input checked="" type="checkbox"/> 1 <input type="checkbox"/> 2 <input type="checkbox"/> 3 Dated: 4/16/2013 and 4/24/2013
Flow Control (incl. facility summary sheet)	Level: <input type="checkbox"/> 1 <input type="checkbox"/> 2 <input type="checkbox"/> 3 or Exemption Number <u>Q<sub>100</sub> increase &lt; 0.1 cfs</u> Small Site BMPs N/A
Conveyance System	Spill containment located at: N/A
Erosion and Sediment Control	ESC Site Supervisor: Craig Buitrago Contact Phone: 206-394-3700 After Hours Phone: 206-394-3700

**TECHNICAL INFORMATION REPORT (TIR) WORKSHEET**

Maintenance and Operation Responsibility:  Private  Public  
 If Private, Maintenance Log Required:  Yes  No

Financial Guarantees and Liability Provided:  Yes  No

Water Quality (include facility summary sheet) Type:  Basic  Sens. Lake  Enhanced Basic  Bog  
 Or Exemption No. 1, Surface Area Exemption  
 Landscape Management Plan:  Yes  No

**Special Requirements (as applicable)**

Area Specific Drainage Requirements Type:  CDA  SDO  MDP  BP  Shared Fac.  None  
 Name:

Floodplain/Floodway Delineation Type:  Major  Minor  Exemption  None  
 100- year Base Flood Elevation (or range): 36.57  
 Datum: NAVD 88

Flood Protection Facilities Describe: N/A

Source Control (comm./ industrial landuse) Describe: N/A  
 Describe any structural controls: N/A

Oil Control High-use Site:  Yes  No  
 Treatment BMP: N/A  
 Maintenance Agreement:  Yes  No  
 With whom? N/A

**Other Drainage Structures**

Describe:

**Threshold Discharge Area**

(name or description): TDA 19: Station 314+00 to 316+40

**Core Requirements (all 8 apply)**

Discharge at Natural Location Number of Natural Discharge Locations: 1

Offsite Analysis: Level:  1  2  3 Dated: 4/16/2013 and 4/24/2013

Flow Control (incl. facility summary sheet) Level:  1  2  3 or Exemption Number Q<sub>100</sub> increase < 0.1 cfs  
 Small Site BMPs N/A

Conveyance System Spill containment located at: N/A

Erosion and Sediment Control ESC Site Supervisor: Craig Buitrago  
 Contact Phone: 206-394-3700  
 After Hours Phone: 206-394-3700

Maintenance and Operation Responsibility:  Private  Public  
 If Private, Maintenance Log Required:  Yes  No

Financial Guarantees and Liability Provided:  Yes  No

Water Quality (include facility summary sheet) Type:  Basic  Sens. Lake  Enhanced Basic  Bog  
 Or Exemption No. 1, Surface Area Exemption  
 Landscape Management Plan:  Yes  No

**Special Requirements (as applicable)**

Area Specific Drainage Requirements Type:  CDA  SDO  MDP  BP  Shared Fac.  None  
 Name:

Floodplain/Floodway Delineation Type:  Major  Minor  Exemption  None  
 100- year Base Flood Elevation (or range): 36.57

**TECHNICAL INFORMATION REPORT (TIR) WORKSHEET**

	Datum: NAVD 88
Flood Protection Facilities	Describe: N/A
Source Control (comm./ industrial landuse)	Describe: N/A Describe any structural controls: N/A
Oil Control	High-use Site: <input type="checkbox"/> Yes <input checked="" type="checkbox"/> No Treatment BMP: N/A Maintenance Agreement: <input type="checkbox"/> Yes <input checked="" type="checkbox"/> No With whom? N/A
<b>Other Drainage Structures</b>	
Describe:	

<b>Threshold Discharge Area</b>	
(name or description):	TDA 20: Station 316+40 to 323+90
<b>Core Requirements (all 8 apply)</b>	
Discharge at Natural Location	Number of Natural Discharge Locations: 1
Offsite Analysis:	Level: <input checked="" type="checkbox"/> 1 <input type="checkbox"/> 2 <input type="checkbox"/> 3 Dated: 4/16/2013 and 4/24/2013
Flow Control (incl. facility summary sheet)	Level: <input type="checkbox"/> 1 <input type="checkbox"/> 2 <input type="checkbox"/> 3 or Exemption Number <u>Q<sub>100</sub> increase &lt; 0.1 cfs</u> Small Site BMPs N/A
Conveyance System	Spill containment located at: N/A
Erosion and Sediment Control	ESC Site Supervisor: Craig Buitrago Contact Phone: 206-394-3700 After Hours Phone: 206-394-3700
Maintenance and Operation	Responsibility: <input type="checkbox"/> Private <input checked="" type="checkbox"/> Public If Private, Maintenance Log Required: <input type="checkbox"/> Yes <input type="checkbox"/> No
Financial Guarantees and Liability	Provided: <input type="checkbox"/> Yes <input checked="" type="checkbox"/> No
Water Quality (include facility summary sheet)	Type: <input type="checkbox"/> Basic <input type="checkbox"/> Sens. Lake <input type="checkbox"/> Enhanced Basic <input type="checkbox"/> Bog Or Exemption No. 1, Surface Area Exemption Landscape Management Plan: <input checked="" type="checkbox"/> Yes <input type="checkbox"/> No
<b>Special Requirements (as applicable)</b>	
Area Specific Drainage Requirements	Type: <input type="checkbox"/> CDA <input type="checkbox"/> SDO <input type="checkbox"/> MDP <input type="checkbox"/> BP <input type="checkbox"/> Shared Fac. <input checked="" type="checkbox"/> None Name:
Floodplain/Floodway Delineation	Type: <input type="checkbox"/> Major <input type="checkbox"/> Minor <input checked="" type="checkbox"/> Exemption <input type="checkbox"/> None 100- year Base Flood Elevation (or range): 36.57 Datum: NAVD 88
Flood Protection Facilities	Describe: N/A
Source Control (comm./ industrial landuse)	Describe: N/A Describe any structural controls: N/A
Oil Control	High-use Site: <input type="checkbox"/> Yes <input checked="" type="checkbox"/> No Treatment BMP: N/A Maintenance Agreement: <input type="checkbox"/> Yes <input checked="" type="checkbox"/> No With whom? N/A
<b>Other Drainage Structures</b>	
Describe:	

**TECHNICAL INFORMATION REPORT (TIR) WORKSHEET**

**Threshold Discharge Area**

(name or description): **TDA 21: Station 323+90 to 328+26**

**Core Requirements (all 8 apply)**

Discharge at Natural Location	Number of Natural Discharge Locations: 1
Offsite Analysis:	Level: <input checked="" type="checkbox"/> 1 <input type="checkbox"/> 2 <input type="checkbox"/> 3 Dated: 4/16/2013 and 4/24/2013
Flow Control (incl. facility summary sheet)	Level: <input type="checkbox"/> 1 <input type="checkbox"/> 2 <input type="checkbox"/> 3 or Exemption Number <u>Q<sub>100</sub> increase &lt; 0.1 cfs</u> Small Site BMPs N/A
Conveyance System	Spill containment located at: N/A
Erosion and Sediment Control	ESC Site Supervisor: Craig Buitrago Contact Phone: 206-394-3700 After Hours Phone: 206-394-3700
Maintenance and Operation	Responsibility: <input type="checkbox"/> Private <input checked="" type="checkbox"/> Public If Private, Maintenance Log Required: <input type="checkbox"/> Yes <input type="checkbox"/> No
Financial Guarantees and Liability	Provided: <input type="checkbox"/> Yes <input checked="" type="checkbox"/> No
Water Quality (include facility summary sheet)	Type: <input type="checkbox"/> Basic <input type="checkbox"/> Sens. Lake <input type="checkbox"/> Enhanced Basic <input type="checkbox"/> Bog Or Exemption No. 1, Surface Area Exemption Landscape Management Plan: <input checked="" type="checkbox"/> Yes <input type="checkbox"/> No

**Special Requirements (as applicable)**

Area Specific Drainage Requirements	Type: <input type="checkbox"/> CDA <input type="checkbox"/> SDO <input type="checkbox"/> MDP <input type="checkbox"/> BP <input type="checkbox"/> Shared Fac. <input checked="" type="checkbox"/> None Name:
Floodplain/Floodway Delineation	Type: <input type="checkbox"/> Major <input type="checkbox"/> Minor <input checked="" type="checkbox"/> Exemption <input type="checkbox"/> None 100- year Base Flood Elevation (or range): 36.57 Datum: NAVD 88
Flood Protection Facilities	Describe: N/A
Source Control (comm./ industrial landuse)	Describe: N/A Describe any structural controls: N/A
Oil Control	High-use Site: <input type="checkbox"/> Yes <input checked="" type="checkbox"/> No Treatment BMP: N/A Maintenance Agreement: <input type="checkbox"/> Yes <input checked="" type="checkbox"/> No With whom? N/A

**Other Drainage Structures**

Describe:

**Threshold Discharge Area**

(name or description): **TDA 22: Station 328+26 to 333+90**

**Core Requirements (all 8 apply)**

Discharge at Natural Location	Number of Natural Discharge Locations: 1
Offsite Analysis:	Level: <input checked="" type="checkbox"/> 1 <input type="checkbox"/> 2 <input type="checkbox"/> 3 Dated: 4/16/2013 and 4/24/2013
Flow Control (incl. facility summary sheet)	Level: <input type="checkbox"/> 1 <input type="checkbox"/> 2 <input type="checkbox"/> 3 or Exemption Number <u>Q<sub>100</sub> increase &lt; 0.1 cfs</u> Small Site BMPs N/A
Conveyance System	Spill containment located at: N/A
Erosion and Sediment Control	ESC Site Supervisor: Craig Buitrago Contact Phone: 206-394-3700 After Hours Phone: 206-394-3700



**TECHNICAL INFORMATION REPORT (TIR) WORKSHEET**

Maintenance and Operation Responsibility:  Private  Public  
 If Private, Maintenance Log Required:  Yes  No

Financial Guarantees and Liability Provided:  Yes  No

Water Quality (include facility summary sheet) Type:  Basic  Sens. Lake  Enhanced Basic  Bog  
 Or Exemption No. 1, Surface Area Exemption  
 Landscape Management Plan:  Yes  No

**Special Requirements (as applicable)**

Area Specific Drainage Requirements Type:  CDA  SDO  MDP  BP  Shared Fac.  None  
 Name:

Floodplain/Floodway Delineation Type:  Major  Minor  Exemption  None  
 100- year Base Flood Elevation (or range): 36.57  
 Datum: NAVD 88

Flood Protection Facilities Describe: N/A

Source Control (comm./ industrial landuse) Describe: N/A  
 Describe any structural controls: N/A

Oil Control High-use Site:  Yes  No  
 Treatment BMP: N/A  
 Maintenance Agreement:  Yes  No  
 With whom? N/A

**Other Drainage Structures**

Describe:

**Threshold Discharge Area**

(name or description): TDA 23: Station 333+90 to 338+00

**Core Requirements (all 8 apply)**

Discharge at Natural Location Number of Natural Discharge Locations: 1

Offsite Analysis: Level:  1  2  3 Dated: 4/16/2013 and 4/24/2013

Flow Control (incl. facility summary sheet) Level:  1  2  3 or Exemption Number Q<sub>100</sub> increase < 0.1 cfs  
 Small Site BMPs N/A

Conveyance System Spill containment located at: N/A

Erosion and Sediment Control ESC Site Supervisor: Craig Buitrago  
 Contact Phone: 206-394-3700  
 After Hours Phone: 206-394-3700

Maintenance and Operation Responsibility:  Private  Public  
 If Private, Maintenance Log Required:  Yes  No

Financial Guarantees and Liability Provided:  Yes  No

Water Quality (include facility summary sheet) Type:  Basic  Sens. Lake  Enhanced Basic  Bog  
 Or Exemption No. 1, Surface Area Exemption  
 Landscape Management Plan:  Yes  No

**Special Requirements (as applicable)**

Area Specific Drainage Requirements Type:  CDA  SDO  MDP  BP  Shared Fac.  None  
 Name:

Floodplain/Floodway Delineation Type:  Major  Minor  Exemption  None  
 100- year Base Flood Elevation (or range): 36.57

**TECHNICAL INFORMATION REPORT (TIR) WORKSHEET**

	Datum: NAVD 88
Flood Protection Facilities	Describe: N/A
Source Control (comm./ industrial landuse)	Describe: N/A Describe any structural controls: N/A
Oil Control	High-use Site: <input type="checkbox"/> Yes <input checked="" type="checkbox"/> No Treatment BMP: N/A Maintenance Agreement: <input type="checkbox"/> Yes <input checked="" type="checkbox"/> No With whom? N/A
<b>Other Drainage Structures</b>	
Describe:	

<b>Threshold Discharge Area</b>	
(name or description):	TDA 24: Station 338+00 to 342+00
<b>Core Requirements (all 8 apply)</b>	
Discharge at Natural Location	Number of Natural Discharge Locations: 1
Offsite Analysis:	Level: <input checked="" type="checkbox"/> 1 <input type="checkbox"/> 2 <input type="checkbox"/> 3      Dated: 4/16/2013 and 4/24/2013
Flow Control (incl. facility summary sheet)	Level: <input type="checkbox"/> 1 <input type="checkbox"/> 2 <input type="checkbox"/> 3      or Exemption Number <u>Q<sub>100</sub> increase &lt; 0.1 cfs</u> Small Site BMPs N/A
Conveyance System	Spill containment located at: N/A
Erosion and Sediment Control	ESC Site Supervisor: Craig Buitrago Contact Phone: 206-394-3700 After Hours Phone: 206-394-3700
Maintenance and Operation	Responsibility: <input type="checkbox"/> Private <input checked="" type="checkbox"/> Public If Private, Maintenance Log Required: <input type="checkbox"/> Yes <input type="checkbox"/> No
Financial Guarantees and Liability	Provided: <input type="checkbox"/> Yes <input checked="" type="checkbox"/> No
Water Quality (include facility summary sheet)	Type: <input type="checkbox"/> Basic <input type="checkbox"/> Sens. Lake <input type="checkbox"/> Enhanced Basic <input type="checkbox"/> Bog Or Exemption No. 1, Surface Area Exemption Landscape Management Plan: <input checked="" type="checkbox"/> Yes <input type="checkbox"/> No
<b>Special Requirements (as applicable)</b>	
Area Specific Drainage Requirements	Type: <input type="checkbox"/> CDA <input type="checkbox"/> SDO <input type="checkbox"/> MDP <input type="checkbox"/> BP <input type="checkbox"/> Shared Fac. <input checked="" type="checkbox"/> None Name:
Floodplain/Floodway Delineation	Type: <input type="checkbox"/> Major <input type="checkbox"/> Minor <input checked="" type="checkbox"/> Exemption <input type="checkbox"/> None 100- year Base Flood Elevation (or range): 36.57 Datum: NAVD 88
Flood Protection Facilities	Describe: N/A
Source Control (comm./ industrial landuse)	Describe: N/A Describe any structural controls: N/A
Oil Control	High-use Site: <input type="checkbox"/> Yes <input checked="" type="checkbox"/> No Treatment BMP: N/A Maintenance Agreement: <input type="checkbox"/> Yes <input checked="" type="checkbox"/> No With whom? N/A
<b>Other Drainage Structures</b>	
Describe:	

**TECHNICAL INFORMATION REPORT (TIR) WORKSHEET**

**Threshold Discharge Area**

(name or description): **TDA 25: Station 342+00 to 347+50**

**Core Requirements (all 8 apply)**

Discharge at Natural Location	Number of Natural Discharge Locations: 1
Offsite Analysis:	Level: <input checked="" type="checkbox"/> 1 <input type="checkbox"/> 2 <input type="checkbox"/> 3 Dated: 4/16/2013 and 4/24/2013
Flow Control (incl. facility summary sheet)	Level: <input type="checkbox"/> 1 <input type="checkbox"/> 2 <input type="checkbox"/> 3 or Exemption Number <u>Q<sub>100</sub> increase &lt; 0.1 cfs</u> Small Site BMPs N/A
Conveyance System	Spill containment located at: N/A
Erosion and Sediment Control	ESC Site Supervisor: Craig Buitrago Contact Phone: 206-394-3700 After Hours Phone: 206-394-3700
Maintenance and Operation	Responsibility: <input type="checkbox"/> Private <input checked="" type="checkbox"/> Public If Private, Maintenance Log Required: <input type="checkbox"/> Yes <input type="checkbox"/> No
Financial Guarantees and Liability	Provided: <input type="checkbox"/> Yes <input checked="" type="checkbox"/> No
Water Quality (include facility summary sheet)	Type: <input type="checkbox"/> Basic <input type="checkbox"/> Sens. Lake <input type="checkbox"/> Enhanced Basic <input type="checkbox"/> Bog Or Exemption No. 1, Surface Area Exemption Landscape Management Plan: <input checked="" type="checkbox"/> Yes <input type="checkbox"/> No

**Special Requirements (as applicable)**

Area Specific Drainage Requirements	Type: <input type="checkbox"/> CDA <input type="checkbox"/> SDO <input type="checkbox"/> MDP <input type="checkbox"/> BP <input type="checkbox"/> Shared Fac. <input checked="" type="checkbox"/> None Name:
Floodplain/Floodway Delineation	Type: <input type="checkbox"/> Major <input type="checkbox"/> Minor <input checked="" type="checkbox"/> Exemption <input type="checkbox"/> None 100- year Base Flood Elevation (or range): 36.57 Datum: NAVD 88
Flood Protection Facilities	Describe: N/A
Source Control (comm./ industrial landuse)	Describe: N/A Describe any structural controls: N/A
Oil Control	High-use Site: <input type="checkbox"/> Yes <input checked="" type="checkbox"/> No Treatment BMP: N/A Maintenance Agreement: <input type="checkbox"/> Yes <input checked="" type="checkbox"/> No With whom? N/A

**Other Drainage Structures**

Describe:

**Threshold Discharge Area**

(name or description): TDA 26: Station 347+50 to 349+90

**Core Requirements (all 8 apply)**

Discharge at Natural Location	Number of Natural Discharge Locations: 1
Offsite Analysis:	Level: <input checked="" type="checkbox"/> 1 <input type="checkbox"/> 2 <input type="checkbox"/> 3 Dated: 4/16/2013 and 4/24/2013
Flow Control (incl. facility summary sheet)	Level: <input type="checkbox"/> 1 <input type="checkbox"/> 2 <input type="checkbox"/> 3 or Exemption Number <u>Q<sub>100</sub> increase &lt; 0.1 cfs</u> Small Site BMPs N/A
Conveyance System	Spill containment located at: N/A
Erosion and Sediment Control	ESC Site Supervisor: Craig Buitrago Contact Phone: 206-394-3700 After Hours Phone: 206-394-3700

**TECHNICAL INFORMATION REPORT (TIR) WORKSHEET**

Maintenance and Operation Responsibility:  Private  Public  
 If Private, Maintenance Log Required:  Yes  No

Financial Guarantees and Liability Provided:  Yes  No

Water Quality (include facility summary sheet) Type:  Basic  Sens. Lake  Enhanced Basic  Bog  
 Or Exemption No. 1, Surface Area Exemption  
 Landscape Management Plan:  Yes  No

**Special Requirements (as applicable)**

Area Specific Drainage Requirements Type:  CDA  SDO  MDP  BP  Shared Fac.  None  
 Name:

Floodplain/Floodway Delineation Type:  Major  Minor  Exemption  None  
 100- year Base Flood Elevation (or range): 36.57  
 Datum: NAVD 88

Flood Protection Facilities Describe: N/A

Source Control (comm./ industrial landuse) Describe: N/A  
 Describe any structural controls: N/A

Oil Control High-use Site:  Yes  No  
 Treatment BMP: N/A  
 Maintenance Agreement:  Yes  No  
 With whom? N/A

**Other Drainage Structures**

Describe:

**Threshold Discharge Area**

(name or description): TDA 27: Station 349+90 to 351+25

**Core Requirements (all 8 apply)**

Discharge at Natural Location Number of Natural Discharge Locations: 1

Offsite Analysis: Level:  1  2  3 Dated: 4/16/2013 and 4/24/2013

Flow Control (incl. facility summary sheet) Level:  1  2  3 or Exemption Number Q<sub>100</sub> increase < 0.1 cfs  
 Small Site BMPs N/A

Conveyance System Spill containment located at: N/A

Erosion and Sediment Control ESC Site Supervisor: Craig Buitrago  
 Contact Phone: 206-394-3700  
 After Hours Phone: 206-394-3700

Maintenance and Operation Responsibility:  Private  Public  
 If Private, Maintenance Log Required:  Yes  No

Financial Guarantees and Liability Provided:  Yes  No

Water Quality (include facility summary sheet) Type:  Basic  Sens. Lake  Enhanced Basic  Bog  
 Or Exemption No. 1, Surface Area Exemption  
 Landscape Management Plan:  Yes  No

**Special Requirements (as applicable)**

Area Specific Drainage Requirements Type:  CDA  SDO  MDP  BP  Shared Fac.  None  
 Name:

Floodplain/Floodway Delineation Type:  Major  Minor  Exemption  None  
 100- year Base Flood Elevation (or range): 36.57

**TECHNICAL INFORMATION REPORT (TIR) WORKSHEET**

	Datum: NAVD 88
Flood Protection Facilities	Describe: N/A
Source Control (comm./ industrial landuse)	Describe: N/A Describe any structural controls: N/A
Oil Control	High-use Site: <input type="checkbox"/> Yes <input checked="" type="checkbox"/> No Treatment BMP: N/A Maintenance Agreement: <input type="checkbox"/> Yes <input checked="" type="checkbox"/> No With whom? N/A
<b>Other Drainage Structures</b>	
Describe:	

<b>Threshold Discharge Area</b>	
(name or description):	TDA 28: Station 351+25 to 353+27
<b>Core Requirements (all 8 apply)</b>	
Discharge at Natural Location	Number of Natural Discharge Locations: 1
Offsite Analysis:	Level: <input checked="" type="checkbox"/> 1 <input type="checkbox"/> 2 <input type="checkbox"/> 3      Dated: 4/16/2013 and 4/24/2013
Flow Control (incl. facility summary sheet)	Level: <input type="checkbox"/> 1 <input type="checkbox"/> 2 <input type="checkbox"/> 3      or Exemption Number <u>Q<sub>100</sub> increase &lt; 0.1 cfs</u> Small Site BMPs N/A
Conveyance System	Spill containment located at: N/A
Erosion and Sediment Control	ESC Site Supervisor: Craig Buitrago Contact Phone: 206-394-3700 After Hours Phone: 206-394-3700
Maintenance and Operation	Responsibility: <input type="checkbox"/> Private <input checked="" type="checkbox"/> Public If Private, Maintenance Log Required: <input type="checkbox"/> Yes <input type="checkbox"/> No
Financial Guarantees and Liability	Provided: <input type="checkbox"/> Yes <input checked="" type="checkbox"/> No
Water Quality (include facility summary sheet)	Type: <input type="checkbox"/> Basic <input type="checkbox"/> Sens. Lake <input type="checkbox"/> Enhanced Basic <input type="checkbox"/> Bog Or Exemption No. 1, Surface Area Exemption Landscape Management Plan: <input checked="" type="checkbox"/> Yes <input type="checkbox"/> No
<b>Special Requirements (as applicable)</b>	
Area Specific Drainage Requirements	Type: <input type="checkbox"/> CDA <input type="checkbox"/> SDO <input type="checkbox"/> MDP <input type="checkbox"/> BP <input type="checkbox"/> Shared Fac. <input checked="" type="checkbox"/> None Name:
Floodplain/Floodway Delineation	Type: <input type="checkbox"/> Major <input type="checkbox"/> Minor <input checked="" type="checkbox"/> Exemption <input type="checkbox"/> None 100- year Base Flood Elevation (or range): 36.57 Datum: NAVD 88
Flood Protection Facilities	Describe: N/A
Source Control (comm./ industrial landuse)	Describe: N/A Describe any structural controls: N/A
Oil Control	High-use Site: <input type="checkbox"/> Yes <input checked="" type="checkbox"/> No Treatment BMP: N/A Maintenance Agreement: <input type="checkbox"/> Yes <input checked="" type="checkbox"/> No With whom? N/A
<b>Other Drainage Structures</b>	
Describe:	

**TECHNICAL INFORMATION REPORT (TIR) WORKSHEET**

**Threshold Discharge Area**

(name or description): TDA 29: Station 353+27 to 359+75

**Core Requirements (all 8 apply)**

Discharge at Natural Location	Number of Natural Discharge Locations: 1
Offsite Analysis:	Level: <input checked="" type="checkbox"/> 1 <input type="checkbox"/> 2 <input type="checkbox"/> 3 Dated: 4/16/2013 and 4/24/2013
Flow Control (incl. facility summary sheet)	Level: <input type="checkbox"/> 1 <input type="checkbox"/> 2 <input type="checkbox"/> 3 or Exemption Number <u>Q<sub>100</sub> increase &lt; 0.1 cfs</u> Small Site BMPs N/A
Conveyance System	Spill containment located at: N/A
Erosion and Sediment Control	ESC Site Supervisor: Craig Buitrago Contact Phone: 206-394-3700 After Hours Phone: 206-394-3700
Maintenance and Operation	Responsibility: <input type="checkbox"/> Private <input checked="" type="checkbox"/> Public If Private, Maintenance Log Required: <input type="checkbox"/> Yes <input type="checkbox"/> No
Financial Guarantees and Liability	Provided: <input type="checkbox"/> Yes <input checked="" type="checkbox"/> No
Water Quality (include facility summary sheet)	Type: <input type="checkbox"/> Basic <input type="checkbox"/> Sens. Lake <input type="checkbox"/> Enhanced Basic <input type="checkbox"/> Bog Or Exemption No. 1, Surface Area Exemption Landscape Management Plan: <input checked="" type="checkbox"/> Yes <input type="checkbox"/> No

**Special Requirements (as applicable)**

Area Specific Drainage Requirements	Type: <input type="checkbox"/> CDA <input type="checkbox"/> SDO <input type="checkbox"/> MDP <input type="checkbox"/> BP <input type="checkbox"/> Shared Fac. <input checked="" type="checkbox"/> None Name:
Floodplain/Floodway Delineation	Type: <input type="checkbox"/> Major <input type="checkbox"/> Minor <input checked="" type="checkbox"/> Exemption <input type="checkbox"/> None 100- year Base Flood Elevation (or range): 36.57 Datum: NAVD 88
Flood Protection Facilities	Describe: N/A
Source Control (comm./ industrial landuse)	Describe: N/A Describe any structural controls: N/A
Oil Control	High-use Site: <input type="checkbox"/> Yes <input checked="" type="checkbox"/> No Treatment BMP: N/A Maintenance Agreement: <input type="checkbox"/> Yes <input checked="" type="checkbox"/> No With whom? N/A

**Other Drainage Structures**

Describe: Infiltration trench from STA 355+40 to STA 359+75

**Threshold Discharge Area**

(name or description): TDA 30: Station 359+75 to 361+15

**Core Requirements (all 8 apply)**

Discharge at Natural Location	Number of Natural Discharge Locations: 1
Offsite Analysis:	Level: <input checked="" type="checkbox"/> 1 <input type="checkbox"/> 2 <input type="checkbox"/> 3 Dated: 4/16/2013 and 4/24/2013
Flow Control (incl. facility summary sheet)	Level: <input type="checkbox"/> 1 <input type="checkbox"/> 2 <input type="checkbox"/> 3 or Exemption Number <u>Q<sub>100</sub> increase &lt; 0.1 cfs</u> Small Site BMPs N/A
Conveyance System	Spill containment located at: N/A
Erosion and Sediment Control	ESC Site Supervisor: Craig Buitrago Contact Phone: 206-394-3700 After Hours Phone: 206-394-3700

**TECHNICAL INFORMATION REPORT (TIR) WORKSHEET**

Maintenance and Operation Responsibility:  Private  Public  
 If Private, Maintenance Log Required:  Yes  No

Financial Guarantees and Liability Provided:  Yes  No

Water Quality (include facility summary sheet) Type:  Basic  Sens. Lake  Enhanced Basic  Bog  
 Or Exemption No. 1, Surface Area Exemption  
 Landscape Management Plan:  Yes  No

**Special Requirements (as applicable)**

Area Specific Drainage Requirements Type:  CDA  SDO  MDP  BP  Shared Fac.  None  
 Name:

Floodplain/Floodway Delineation Type:  Major  Minor  Exemption  None  
 100- year Base Flood Elevation (or range): 36.57  
 Datum: NAVD 88

Flood Protection Facilities Describe: N/A

Source Control (comm./ industrial landuse) Describe: N/A  
 Describe any structural controls: N/A

Oil Control High-use Site:  Yes  No  
 Treatment BMP: N/A  
 Maintenance Agreement:  Yes  No  
 With whom? N/A

**Other Drainage Structures**

Describe:

**Threshold Discharge Area**

(name or description): TDA 30A: Station 361+15 to 362+16

**Core Requirements (all 8 apply)**

Discharge at Natural Location Number of Natural Discharge Locations: 1

Offsite Analysis: Level:  1  2  3 Dated: 4/16/2013 and 4/24/2013

Flow Control (incl. facility summary sheet) Level:  1  2  3 or Exemption Number Q<sub>100</sub> increase < 0.1 cfs  
 Small Site BMPs N/A

Conveyance System Spill containment located at: N/A

Erosion and Sediment Control ESC Site Supervisor: Craig Buitrago  
 Contact Phone: 206-394-3700  
 After Hours Phone: 206-394-3700

Maintenance and Operation Responsibility:  Private  Public  
 If Private, Maintenance Log Required:  Yes  No

Financial Guarantees and Liability Provided:  Yes  No

Water Quality (include facility summary sheet) Type:  Basic  Sens. Lake  Enhanced Basic  Bog  
 Or Exemption No. 1, Surface Area Exemption  
 Landscape Management Plan:  Yes  No

**Special Requirements (as applicable)**

Area Specific Drainage Requirements Type:  CDA  SDO  MDP  BP  Shared Fac.  None  
 Name:

Floodplain/Floodway Delineation Type:  Major  Minor  Exemption  None  
 100- year Base Flood Elevation (or range): 36.57

**TECHNICAL INFORMATION REPORT (TIR) WORKSHEET**

	Datum: NAVD 88
Flood Protection Facilities	Describe: N/A
Source Control (comm./ industrial landuse)	Describe: N/A Describe any structural controls: N/A
Oil Control	High-use Site: <input type="checkbox"/> Yes <input checked="" type="checkbox"/> No Treatment BMP: N/A Maintenance Agreement: <input type="checkbox"/> Yes <input checked="" type="checkbox"/> No With whom? N/A
<b>Other Drainage Structures</b>	
Describe:	

<b>Threshold Discharge Area</b>	
(name or description):	TDA 31: Station 362+16 to 365+75
<b>Core Requirements (all 8 apply)</b>	
Discharge at Natural Location	Number of Natural Discharge Locations: 1
Offsite Analysis:	Level: <input checked="" type="checkbox"/> 1 <input type="checkbox"/> 2 <input type="checkbox"/> 3      Dated: 4/16/2013 and 4/24/2013
Flow Control (incl. facility summary sheet)	Level: <input type="checkbox"/> 1 <input type="checkbox"/> 2 <input type="checkbox"/> 3      or Exemption Number <u>Q<sub>100</sub> increase &lt; 0.1 cfs</u> Small Site BMPs N/A
Conveyance System	Spill containment located at: N/A
Erosion and Sediment Control	ESC Site Supervisor: Craig Buitrago Contact Phone: 206-394-3700 After Hours Phone: 206-394-3700
Maintenance and Operation	Responsibility: <input type="checkbox"/> Private <input checked="" type="checkbox"/> Public If Private, Maintenance Log Required: <input type="checkbox"/> Yes <input type="checkbox"/> No
Financial Guarantees and Liability	Provided: <input type="checkbox"/> Yes <input checked="" type="checkbox"/> No
Water Quality (include facility summary sheet)	Type: <input type="checkbox"/> Basic <input type="checkbox"/> Sens. Lake <input type="checkbox"/> Enhanced Basic <input type="checkbox"/> Bog Or Exemption No. 1, Surface Area Exemption Landscape Management Plan: <input checked="" type="checkbox"/> Yes <input type="checkbox"/> No
<b>Special Requirements (as applicable)</b>	
Area Specific Drainage Requirements	Type: <input type="checkbox"/> CDA <input type="checkbox"/> SDO <input type="checkbox"/> MDP <input type="checkbox"/> BP <input type="checkbox"/> Shared Fac. <input checked="" type="checkbox"/> None Name:
Floodplain/Floodway Delineation	Type: <input type="checkbox"/> Major <input type="checkbox"/> Minor <input checked="" type="checkbox"/> Exemption <input type="checkbox"/> None 100- year Base Flood Elevation (or range): 36.57 Datum: NAVD 88
Flood Protection Facilities	Describe: N/A
Source Control (comm./ industrial landuse)	Describe: N/A Describe any structural controls: N/A
Oil Control	High-use Site: <input type="checkbox"/> Yes <input checked="" type="checkbox"/> No Treatment BMP: N/A Maintenance Agreement: <input type="checkbox"/> Yes <input checked="" type="checkbox"/> No With whom? N/A
<b>Other Drainage Structures</b>	
Describe:	



**TECHNICAL INFORMATION REPORT (TIR) WORKSHEET**

**Threshold Discharge Area**

(name or description): TDA 32: Station 365+75 to 367+75

**Core Requirements (all 8 apply)**

Discharge at Natural Location	Number of Natural Discharge Locations: 1
Offsite Analysis:	Level: <input checked="" type="checkbox"/> 1 <input type="checkbox"/> 2 <input type="checkbox"/> 3 Dated: 4/16/2013 and 4/24/2013
Flow Control (incl. facility summary sheet)	Level: <input type="checkbox"/> 1 <input type="checkbox"/> 2 <input type="checkbox"/> 3 or Exemption Number <u>Q<sub>100</sub> increase &lt; 0.1 cfs</u> Small Site BMPs N/A
Conveyance System	Spill containment located at: N/A
Erosion and Sediment Control	ESC Site Supervisor: Craig Buitrago Contact Phone: 206-394-3700 After Hours Phone: 206-394-3700
Maintenance and Operation	Responsibility: <input type="checkbox"/> Private <input checked="" type="checkbox"/> Public If Private, Maintenance Log Required: <input type="checkbox"/> Yes <input type="checkbox"/> No
Financial Guarantees and Liability	Provided: <input type="checkbox"/> Yes <input checked="" type="checkbox"/> No
Water Quality (include facility summary sheet)	Type: <input type="checkbox"/> Basic <input type="checkbox"/> Sens. Lake <input type="checkbox"/> Enhanced Basic <input type="checkbox"/> Bog Or Exemption No. 1, Surface Area Exemption Landscape Management Plan: <input checked="" type="checkbox"/> Yes <input type="checkbox"/> No

**Special Requirements (as applicable)**

Area Specific Drainage Requirements	Type: <input type="checkbox"/> CDA <input type="checkbox"/> SDO <input type="checkbox"/> MDP <input type="checkbox"/> BP <input type="checkbox"/> Shared Fac. <input checked="" type="checkbox"/> None Name:
Floodplain/Floodway Delineation	Type: <input type="checkbox"/> Major <input type="checkbox"/> Minor <input checked="" type="checkbox"/> Exemption <input type="checkbox"/> None 100- year Base Flood Elevation (or range): 36.57 Datum: NAVD 88
Flood Protection Facilities	Describe: N/A
Source Control (comm./ industrial landuse)	Describe: N/A Describe any structural controls: N/A
Oil Control	High-use Site: <input type="checkbox"/> Yes <input checked="" type="checkbox"/> No Treatment BMP: N/A Maintenance Agreement: <input type="checkbox"/> Yes <input checked="" type="checkbox"/> No With whom? N/A

**Other Drainage Structures**

Describe:

**Threshold Discharge Area**

(name or description): TDA 33: Station 367+75 to 371+00

**Core Requirements (all 8 apply)**

Discharge at Natural Location	Number of Natural Discharge Locations: 1
Offsite Analysis:	Level: <input checked="" type="checkbox"/> 1 <input type="checkbox"/> 2 <input type="checkbox"/> 3 Dated: 4/16/2013 and 4/24/2013
Flow Control (incl. facility summary sheet)	Level: <input type="checkbox"/> 1 <input type="checkbox"/> 2 <input type="checkbox"/> 3 or Exemption Number <u>Q<sub>100</sub> increase &lt; 0.1 cfs</u> Small Site BMPs N/A
Conveyance System	Spill containment located at: N/A
Erosion and Sediment Control	ESC Site Supervisor: Craig Buitrago Contact Phone: 206-394-3700 After Hours Phone: 206-394-3700

**TECHNICAL INFORMATION REPORT (TIR) WORKSHEET**

Maintenance and Operation Responsibility:  Private  Public  
 If Private, Maintenance Log Required:  Yes  No

Financial Guarantees and Liability Provided:  Yes  No

Water Quality (include facility summary sheet) Type:  Basic  Sens. Lake  Enhanced Basic  Bog  
 Or Exemption No. 1, Surface Area Exemption  
 Landscape Management Plan:  Yes  No

**Special Requirements (as applicable)**

Area Specific Drainage Requirements Type:  CDA  SDO  MDP  BP  Shared Fac.  None  
 Name:

Floodplain/Floodway Delineation Type:  Major  Minor  Exemption  None  
 100- year Base Flood Elevation (or range): 36.57  
 Datum: NAVD 88

Flood Protection Facilities Describe: N/A

Source Control (comm./ industrial landuse) Describe: N/A  
 Describe any structural controls: N/A

Oil Control High-use Site:  Yes  No  
 Treatment BMP: N/A  
 Maintenance Agreement:  Yes  No  
 With whom? N/A

**Other Drainage Structures**

Describe:

**Threshold Discharge Area**

(name or description): TDA 34: Station 371+50 to 378+80

**Core Requirements (all 8 apply)**

Discharge at Natural Location Number of Natural Discharge Locations: 1

Offsite Analysis: Level:  1  2  3 Dated: 4/16/2013 and 4/24/2013

Flow Control (incl. facility summary sheet) Level:  1  2  3 or Exemption Number Q<sub>100</sub> increase < 0.1 cfs  
 Small Site BMPs N/A

Conveyance System Spill containment located at: N/A

Erosion and Sediment Control ESC Site Supervisor: Craig Buitrago  
 Contact Phone: 206-394-3700  
 After Hours Phone: 206-394-3700

Maintenance and Operation Responsibility:  Private  Public  
 If Private, Maintenance Log Required:  Yes  No

Financial Guarantees and Liability Provided:  Yes  No

Water Quality (include facility summary sheet) Type:  Basic  Sens. Lake  Enhanced Basic  Bog  
 Or Exemption No. 1, Surface Area Exemption  
 Landscape Management Plan:  Yes  No

**Special Requirements (as applicable)**

Area Specific Drainage Requirements Type:  CDA  SDO  MDP  BP  Shared Fac.  None  
 Name:

Floodplain/Floodway Delineation Type:  Major  Minor  Exemption  None  
 100- year Base Flood Elevation (or range): 36.57

**TECHNICAL INFORMATION REPORT (TIR) WORKSHEET**

	Datum: NAVD 88
Flood Protection Facilities	Describe: N/A
Source Control (comm./ industrial landuse)	Describe: N/A Describe any structural controls: N/A
Oil Control	High-use Site: <input type="checkbox"/> Yes <input checked="" type="checkbox"/> No Treatment BMP: N/A Maintenance Agreement: <input type="checkbox"/> Yes <input checked="" type="checkbox"/> No With whom? N/A
<b>Other Drainage Structures</b>	
Describe: Infiltration trench from STA 371+71 to 378+80	

<b>Threshold Discharge Area</b>	
(name or description):	TDA 35: Station 378+80 to 382+00
<b>Core Requirements (all 8 apply)</b>	
Discharge at Natural Location	Number of Natural Discharge Locations: 1
Offsite Analysis:	Level: <input checked="" type="checkbox"/> 1 <input type="checkbox"/> 2 <input type="checkbox"/> 3      Dated: 4/16/2013 and 4/24/2013
Flow Control (incl. facility summary sheet)	Level: <input type="checkbox"/> 1 <input type="checkbox"/> 2 <input type="checkbox"/> 3      or Exemption Number <u>Q<sub>100</sub> increase &lt; 0.1 cfs</u> Small Site BMPs N/A
Conveyance System	Spill containment located at: N/A
Erosion and Sediment Control	ESC Site Supervisor: Craig Buitrago Contact Phone: 206-394-3700 After Hours Phone: 206-394-3700
Maintenance and Operation	Responsibility: <input type="checkbox"/> Private <input checked="" type="checkbox"/> Public If Private, Maintenance Log Required: <input type="checkbox"/> Yes <input type="checkbox"/> No
Financial Guarantees and Liability	Provided: <input type="checkbox"/> Yes <input checked="" type="checkbox"/> No
Water Quality (include facility summary sheet)	Type: <input type="checkbox"/> Basic <input type="checkbox"/> Sens. Lake <input type="checkbox"/> Enhanced Basic <input type="checkbox"/> Bog Or Exemption No. 1, Surface Area Exemption Landscape Management Plan: <input checked="" type="checkbox"/> Yes <input type="checkbox"/> No
<b>Special Requirements (as applicable)</b>	
Area Specific Drainage Requirements	Type: <input type="checkbox"/> CDA <input type="checkbox"/> SDO <input type="checkbox"/> MDP <input type="checkbox"/> BP <input type="checkbox"/> Shared Fac. <input checked="" type="checkbox"/> None Name:
Floodplain/Floodway Delineation	Type: <input type="checkbox"/> Major <input type="checkbox"/> Minor <input checked="" type="checkbox"/> Exemption <input type="checkbox"/> None 100- year Base Flood Elevation (or range): 36.57 Datum: NAVD 88
Flood Protection Facilities	Describe: N/A
Source Control (comm./ industrial landuse)	Describe: N/A Describe any structural controls: N/A
Oil Control	High-use Site: <input type="checkbox"/> Yes <input checked="" type="checkbox"/> No Treatment BMP: N/A Maintenance Agreement: <input type="checkbox"/> Yes <input checked="" type="checkbox"/> No With whom? N/A
<b>Other Drainage Structures</b>	
Describe:	

**TECHNICAL INFORMATION REPORT (TIR) WORKSHEET**

**Threshold Discharge Area**

(name or description): TDA 36: Station 382+00 to 385+30

**Core Requirements (all 8 apply)**

Discharge at Natural Location	Number of Natural Discharge Locations: 1
Offsite Analysis:	Level: <input checked="" type="checkbox"/> 1 <input type="checkbox"/> 2 <input type="checkbox"/> 3 Dated: 4/16/2013 and 4/24/2013
Flow Control (incl. facility summary sheet)	Level: <input type="checkbox"/> 1 <input type="checkbox"/> 2 <input type="checkbox"/> 3 or Exemption Number <u>Q<sub>100</sub> increase &lt; 0.1 cfs</u> Small Site BMPs N/A
Conveyance System	Spill containment located at: N/A
Erosion and Sediment Control	ESC Site Supervisor: Craig Buitrago Contact Phone: 206-394-3700 After Hours Phone: 206-394-3700
Maintenance and Operation	Responsibility: <input type="checkbox"/> Private <input checked="" type="checkbox"/> Public If Private, Maintenance Log Required: <input type="checkbox"/> Yes <input type="checkbox"/> No
Financial Guarantees and Liability	Provided: <input type="checkbox"/> Yes <input checked="" type="checkbox"/> No
Water Quality (include facility summary sheet)	Type: <input type="checkbox"/> Basic <input type="checkbox"/> Sens. Lake <input type="checkbox"/> Enhanced Basic <input type="checkbox"/> Bog Or Exemption No. 1, Surface Area Exemption Landscape Management Plan: <input checked="" type="checkbox"/> Yes <input type="checkbox"/> No

**Special Requirements (as applicable)**

Area Specific Drainage Requirements	Type: <input type="checkbox"/> CDA <input type="checkbox"/> SDO <input type="checkbox"/> MDP <input type="checkbox"/> BP <input type="checkbox"/> Shared Fac. <input checked="" type="checkbox"/> None Name:
Floodplain/Floodway Delineation	Type: <input type="checkbox"/> Major <input type="checkbox"/> Minor <input checked="" type="checkbox"/> Exemption <input type="checkbox"/> None 100- year Base Flood Elevation (or range): 36.57 Datum: NAVD 88
Flood Protection Facilities	Describe: N/A
Source Control (comm./ industrial landuse)	Describe: N/A Describe any structural controls: N/A
Oil Control	High-use Site: <input type="checkbox"/> Yes <input checked="" type="checkbox"/> No Treatment BMP: N/A Maintenance Agreement: <input type="checkbox"/> Yes <input checked="" type="checkbox"/> No With whom? N/A

**Other Drainage Structures**

Describe:

**Threshold Discharge Area**

(name or description): TDA 37: Station 385+30 to 390+35

**Core Requirements (all 8 apply)**

Discharge at Natural Location	Number of Natural Discharge Locations: 1
Offsite Analysis:	Level: <input checked="" type="checkbox"/> 1 <input type="checkbox"/> 2 <input type="checkbox"/> 3 Dated: 4/16/2013 and 4/24/2013
Flow Control (incl. facility summary sheet)	Level: <input type="checkbox"/> 1 <input type="checkbox"/> 2 <input type="checkbox"/> 3 or Exemption Number <u>Basic Dispersion</u> Small Site BMPs N/A
Conveyance System	Spill containment located at: N/A
Erosion and Sediment Control	ESC Site Supervisor: Craig Buitrago Contact Phone: 206-394-3700 After Hours Phone: 206-394-3700

**TECHNICAL INFORMATION REPORT (TIR) WORKSHEET**

Maintenance and Operation Responsibility:  Private  Public  
 If Private, Maintenance Log Required:  Yes  No

Financial Guarantees and Liability Provided:  Yes  No

Water Quality (include facility summary sheet) Type:  Basic  Sens. Lake  Enhanced Basic  Bog  
 Or Exemption No. 1, Surface Area Exemption  
 Landscape Management Plan:  Yes  No

**Special Requirements (as applicable)**

Area Specific Drainage Requirements Type:  CDA  SDO  MDP  BP  Shared Fac.  None  
 Name:

Floodplain/Floodway Delineation Type:  Major  Minor  Exemption  None  
 100- year Base Flood Elevation (or range): 36.57  
 Datum: NAVD 88

Flood Protection Facilities Describe: N/A

Source Control (comm./ industrial landuse) Describe: N/A  
 Describe any structural controls: N/A

Oil Control High-use Site:  Yes  No  
 Treatment BMP: N/A  
 Maintenance Agreement:  Yes  No  
 With whom? N/A

**Other Drainage Structures**

Describe:

**Threshold Discharge Area**

(name or description): TDA 38: Station 390+35 to 391+85

**Core Requirements (all 8 apply)**

Discharge at Natural Location Number of Natural Discharge Locations: 1

Offsite Analysis: Level:  1  2  3 Dated: 4/16/2013 and 4/24/2013

Flow Control (incl. facility summary sheet) Level:  1  2  3 or Exemption Number Q<sub>100</sub> increase < 0.1 cfs  
 Small Site BMPs N/A

Conveyance System Spill containment located at: N/A

Erosion and Sediment Control ESC Site Supervisor: Craig Buitrago  
 Contact Phone: 206-394-3700  
 After Hours Phone: 206-394-3700

Maintenance and Operation Responsibility:  Private  Public  
 If Private, Maintenance Log Required:  Yes  No

Financial Guarantees and Liability Provided:  Yes  No

Water Quality (include facility summary sheet) Type:  Basic  Sens. Lake  Enhanced Basic  Bog  
 Or Exemption No. 1, Surface Area Exemption  
 Landscape Management Plan:  Yes  No

**Special Requirements (as applicable)**

Area Specific Drainage Requirements Type:  CDA  SDO  MDP  BP  Shared Fac.  None  
 Name:

Floodplain/Floodway Delineation Type:  Major  Minor  Exemption  None  
 100- year Base Flood Elevation (or range): 36.57

**TECHNICAL INFORMATION REPORT (TIR) WORKSHEET**

	Datum: NAVD 88
Flood Protection Facilities	Describe: N/A
Source Control (comm./ industrial landuse)	Describe: N/A Describe any structural controls: N/A
Oil Control	High-use Site: <input type="checkbox"/> Yes <input checked="" type="checkbox"/> No Treatment BMP: N/A Maintenance Agreement: <input type="checkbox"/> Yes <input checked="" type="checkbox"/> No With whom? N/A
<b>Other Drainage Structures</b>	
Describe:	

<b>Threshold Discharge Area</b>	
(name or description):	TDA 39: Station 391+85 to 393+30
<b>Core Requirements (all 8 apply)</b>	
Discharge at Natural Location	Number of Natural Discharge Locations: 1
Offsite Analysis:	Level: <input checked="" type="checkbox"/> 1 <input type="checkbox"/> 2 <input type="checkbox"/> 3      Dated: 4/16/2013 and 4/24/2013
Flow Control (incl. facility summary sheet)	Level: <input type="checkbox"/> 1 <input type="checkbox"/> 2 <input type="checkbox"/> 3      or Exemption Number <u>Q<sub>100</sub> increase &lt; 0.1 cfs</u> Small Site BMPs N/A
Conveyance System	Spill containment located at: N/A
Erosion and Sediment Control	ESC Site Supervisor: Craig Buitrago Contact Phone: 206-394-3700 After Hours Phone: 206-394-3700
Maintenance and Operation	Responsibility: <input type="checkbox"/> Private <input checked="" type="checkbox"/> Public If Private, Maintenance Log Required: <input type="checkbox"/> Yes <input type="checkbox"/> No
Financial Guarantees and Liability	Provided: <input type="checkbox"/> Yes <input checked="" type="checkbox"/> No
Water Quality (include facility summary sheet)	Type: <input type="checkbox"/> Basic <input type="checkbox"/> Sens. Lake <input type="checkbox"/> Enhanced Basic <input type="checkbox"/> Bog Or Exemption No. 1, Surface Area Exemption Landscape Management Plan: <input checked="" type="checkbox"/> Yes <input type="checkbox"/> No
<b>Special Requirements (as applicable)</b>	
Area Specific Drainage Requirements	Type: <input type="checkbox"/> CDA <input type="checkbox"/> SDO <input type="checkbox"/> MDP <input type="checkbox"/> BP <input type="checkbox"/> Shared Fac. <input checked="" type="checkbox"/> None Name:
Floodplain/Floodway Delineation	Type: <input type="checkbox"/> Major <input type="checkbox"/> Minor <input checked="" type="checkbox"/> Exemption <input type="checkbox"/> None 100- year Base Flood Elevation (or range): 36.57 Datum: NAVD 88
Flood Protection Facilities	Describe: N/A
Source Control (comm./ industrial landuse)	Describe: N/A Describe any structural controls: N/A
Oil Control	High-use Site: <input type="checkbox"/> Yes <input checked="" type="checkbox"/> No Treatment BMP: N/A Maintenance Agreement: <input type="checkbox"/> Yes <input checked="" type="checkbox"/> No With whom? N/A
<b>Other Drainage Structures</b>	
Describe:	

**TECHNICAL INFORMATION REPORT (TIR) WORKSHEET**

**Threshold Discharge Area**

(name or description): TDA 40: Station 393+30 to 395+80

**Core Requirements (all 8 apply)**

Discharge at Natural Location	Number of Natural Discharge Locations: 1
Offsite Analysis:	Level: <input checked="" type="checkbox"/> 1 <input type="checkbox"/> 2 <input type="checkbox"/> 3 Dated: 4/16/2013 and 4/24/2013
Flow Control (incl. facility summary sheet)	Level: <input type="checkbox"/> 1 <input type="checkbox"/> 2 <input type="checkbox"/> 3 or Exemption Number <u>Q<sub>100</sub> increase &lt; 0.1 cfs</u> Small Site BMPs N/A
Conveyance System	Spill containment located at: N/A
Erosion and Sediment Control	ESC Site Supervisor: Craig Buitrago Contact Phone: 206-394-3700 After Hours Phone: 206-394-3700
Maintenance and Operation	Responsibility: <input type="checkbox"/> Private <input checked="" type="checkbox"/> Public If Private, Maintenance Log Required: <input type="checkbox"/> Yes <input type="checkbox"/> No
Financial Guarantees and Liability	Provided: <input type="checkbox"/> Yes <input checked="" type="checkbox"/> No
Water Quality (include facility summary sheet)	Type: <input type="checkbox"/> Basic <input type="checkbox"/> Sens. Lake <input type="checkbox"/> Enhanced Basic <input type="checkbox"/> Bog Or Exemption No. 1, Surface Area Exemption Landscape Management Plan: <input checked="" type="checkbox"/> Yes <input type="checkbox"/> No

**Special Requirements (as applicable)**

Area Specific Drainage Requirements	Type: <input type="checkbox"/> CDA <input type="checkbox"/> SDO <input type="checkbox"/> MDP <input type="checkbox"/> BP <input type="checkbox"/> Shared Fac. <input checked="" type="checkbox"/> None Name:
Floodplain/Floodway Delineation	Type: <input type="checkbox"/> Major <input type="checkbox"/> Minor <input checked="" type="checkbox"/> Exemption <input type="checkbox"/> None 100- year Base Flood Elevation (or range): 36.57 Datum: NAVD 88
Flood Protection Facilities	Describe: N/A
Source Control (comm./ industrial landuse)	Describe: N/A Describe any structural controls: N/A
Oil Control	High-use Site: <input type="checkbox"/> Yes <input checked="" type="checkbox"/> No Treatment BMP: N/A Maintenance Agreement: <input type="checkbox"/> Yes <input checked="" type="checkbox"/> No With whom? N/A

**Other Drainage Structures**

Describe:

**Threshold Discharge Area**

(name or description): TDA 41: Station 395+80 to 402+30

**Core Requirements (all 8 apply)**

Discharge at Natural Location	Number of Natural Discharge Locations: 1
Offsite Analysis:	Level: <input checked="" type="checkbox"/> 1 <input type="checkbox"/> 2 <input type="checkbox"/> 3 Dated: 4/16/2013 and 4/24/2013
Flow Control (incl. facility summary sheet)	Level: <input type="checkbox"/> 1 <input type="checkbox"/> 2 <input type="checkbox"/> 3 or Exemption Number <u>Basic Dispersion</u> Small Site BMPs N/A
Conveyance System	Spill containment located at: N/A
Erosion and Sediment Control	ESC Site Supervisor: Craig Buitrago Contact Phone: 206-394-3700 After Hours Phone: 206-394-3700

**TECHNICAL INFORMATION REPORT (TIR) WORKSHEET**

Maintenance and Operation Responsibility:  Private  Public  
 If Private, Maintenance Log Required:  Yes  No

Financial Guarantees and Liability Provided:  Yes  No

Water Quality (include facility summary sheet) Type:  Basic  Sens. Lake  Enhanced Basic  Bog  
 Or Exemption No. 1, Surface Area Exemption  
 Landscape Management Plan:  Yes  No

**Special Requirements (as applicable)**

Area Specific Drainage Requirements Type:  CDA  SDO  MDP  BP  Shared Fac.  None  
 Name:

Floodplain/Floodway Delineation Type:  Major  Minor  Exemption  None  
 100- year Base Flood Elevation (or range): 36.57  
 Datum: NAVD 88

Flood Protection Facilities Describe: N/A

Source Control (comm./ industrial landuse) Describe: N/A  
 Describe any structural controls: N/A

Oil Control High-use Site:  Yes  No  
 Treatment BMP: N/A  
 Maintenance Agreement:  Yes  No  
 With whom? N/A

**Other Drainage Structures**

Describe:

**Threshold Discharge Area**

(name or description): TDA 42: Station 402+30 to 403+50

**Core Requirements (all 8 apply)**

Discharge at Natural Location Number of Natural Discharge Locations: 1

Offsite Analysis: Level:  1  2  3 Dated: 4/16/2013 and 4/24/2013

Flow Control (incl. facility summary sheet) Level:  1  2  3 or Exemption Number Q<sub>100</sub> increase < 0.1 cfs  
 Small Site BMPs N/A

Conveyance System Spill containment located at: N/A

Erosion and Sediment Control ESC Site Supervisor: Craig Buitrago  
 Contact Phone: 206-394-3700  
 After Hours Phone: 206-394-3700

Maintenance and Operation Responsibility:  Private  Public  
 If Private, Maintenance Log Required:  Yes  No

Financial Guarantees and Liability Provided:  Yes  No

Water Quality (include facility summary sheet) Type:  Basic  Sens. Lake  Enhanced Basic  Bog  
 Or Exemption No. 1, Surface Area Exemption  
 Landscape Management Plan:  Yes  No

**Special Requirements (as applicable)**

Area Specific Drainage Requirements Type:  CDA  SDO  MDP  BP  Shared Fac.  None  
 Name:

Floodplain/Floodway Delineation Type:  Major  Minor  Exemption  None  
 100- year Base Flood Elevation (or range): 36.57



**TECHNICAL INFORMATION REPORT (TIR) WORKSHEET**

	Datum: NAVD 88
Flood Protection Facilities	Describe: N/A
Source Control (comm./ industrial landuse)	Describe: N/A Describe any structural controls: N/A
Oil Control	High-use Site: <input type="checkbox"/> Yes <input checked="" type="checkbox"/> No Treatment BMP: N/A Maintenance Agreement: <input type="checkbox"/> Yes <input checked="" type="checkbox"/> No With whom? N/A
<b>Other Drainage Structures</b>	
Describe: Infiltration trench from STA 395+90 TO 399+02	
<b>Threshold Discharge Area</b>	
(name or description):	TDA 43: Station 403+50 to 405+40
<b>Core Requirements (all 8 apply)</b>	
Discharge at Natural Location	Number of Natural Discharge Locations: 1
Offsite Analysis:	Level: <input checked="" type="checkbox"/> 1 <input type="checkbox"/> 2 <input type="checkbox"/> 3 Dated: 4/16/2013 and 4/24/2013
Flow Control (incl. facility summary sheet)	Level: <input type="checkbox"/> 1 <input type="checkbox"/> 2 <input type="checkbox"/> 3 or Exemption Number <u>Q<sub>100</sub> increase &lt; 0.1 cfs</u> Small Site BMPs N/A
Conveyance System	Spill containment located at: N/A
Erosion and Sediment Control	ESC Site Supervisor: Craig Buitrago Contact Phone: 206-394-3700 After Hours Phone: 206-394-3700
Maintenance and Operation	Responsibility: <input type="checkbox"/> Private <input checked="" type="checkbox"/> Public If Private, Maintenance Log Required: <input type="checkbox"/> Yes <input type="checkbox"/> No
Financial Guarantees and Liability	Provided: <input type="checkbox"/> Yes <input checked="" type="checkbox"/> No
Water Quality (include facility summary sheet)	Type: <input type="checkbox"/> Basic <input type="checkbox"/> Sens. Lake <input type="checkbox"/> Enhanced Basic <input type="checkbox"/> Bog Or Exemption No. 1, Surface Area Exemption Landscape Management Plan: <input checked="" type="checkbox"/> Yes <input type="checkbox"/> No
<b>Special Requirements (as applicable)</b>	
Area Specific Drainage Requirements	Type: <input type="checkbox"/> CDA <input type="checkbox"/> SDO <input type="checkbox"/> MDP <input type="checkbox"/> BP <input type="checkbox"/> Shared Fac. <input checked="" type="checkbox"/> None Name:
Floodplain/Floodway Delineation	Type: <input type="checkbox"/> Major <input type="checkbox"/> Minor <input checked="" type="checkbox"/> Exemption <input type="checkbox"/> None 100- year Base Flood Elevation (or range): 36.57 Datum: NAVD 88
Flood Protection Facilities	Describe: N/A
Source Control (comm./ industrial landuse)	Describe: N/A Describe any structural controls: N/A
Oil Control	High-use Site: <input type="checkbox"/> Yes <input checked="" type="checkbox"/> No Treatment BMP: N/A Maintenance Agreement: <input type="checkbox"/> Yes <input checked="" type="checkbox"/> No With whom? N/A
<b>Other Drainage Structures</b>	
Describe:	

**TECHNICAL INFORMATION REPORT (TIR) WORKSHEET**

**Threshold Discharge Area**

(name or description): TDA 44: Station 405+40 to 405+60

**Core Requirements (all 8 apply)**

Discharge at Natural Location	Number of Natural Discharge Locations: 1
Offsite Analysis:	Level: <input checked="" type="checkbox"/> 1 <input type="checkbox"/> 2 <input type="checkbox"/> 3 Dated: 4/16/2013 and 4/24/2013
Flow Control (incl. facility summary sheet)	Level: <input type="checkbox"/> 1 <input type="checkbox"/> 2 <input type="checkbox"/> 3 or Exemption Number <u>Q<sub>100</sub> increase &lt; 0.1 cfs</u> Small Site BMPs N/A
Conveyance System	Spill containment located at: N/A
Erosion and Sediment Control	ESC Site Supervisor: Craig Buitrago Contact Phone: 206-394-3700 After Hours Phone: 206-394-3700
Maintenance and Operation	Responsibility: <input type="checkbox"/> Private <input checked="" type="checkbox"/> Public If Private, Maintenance Log Required: <input type="checkbox"/> Yes <input type="checkbox"/> No
Financial Guarantees and Liability	Provided: <input type="checkbox"/> Yes <input checked="" type="checkbox"/> No
Water Quality (include facility summary sheet)	Type: <input type="checkbox"/> Basic <input type="checkbox"/> Sens. Lake <input type="checkbox"/> Enhanced Basic <input type="checkbox"/> Bog Or Exemption No. 1, Surface Area Exemption Landscape Management Plan: <input checked="" type="checkbox"/> Yes <input type="checkbox"/> No

**Special Requirements (as applicable)**

Area Specific Drainage Requirements	Type: <input type="checkbox"/> CDA <input type="checkbox"/> SDO <input type="checkbox"/> MDP <input type="checkbox"/> BP <input type="checkbox"/> Shared Fac. <input checked="" type="checkbox"/> None Name:
Floodplain/Floodway Delineation	Type: <input type="checkbox"/> Major <input type="checkbox"/> Minor <input checked="" type="checkbox"/> Exemption <input type="checkbox"/> None 100- year Base Flood Elevation (or range): 36.57 Datum: NAVD 88
Flood Protection Facilities	Describe: N/A
Source Control (comm./ industrial landuse)	Describe: N/A Describe any structural controls: N/A
Oil Control	High-use Site: <input type="checkbox"/> Yes <input checked="" type="checkbox"/> No Treatment BMP: N/A Maintenance Agreement: <input type="checkbox"/> Yes <input checked="" type="checkbox"/> No With whom? N/A

**Other Drainage Structures**

Describe:

**Threshold Discharge Area**

(name or description): TDA 45: Station 405+60 to 406+68

**Core Requirements (all 8 apply)**

Discharge at Natural Location	Number of Natural Discharge Locations: 1
Offsite Analysis:	Level: <input checked="" type="checkbox"/> 1 <input type="checkbox"/> 2 <input type="checkbox"/> 3 Dated: 4/16/2013 and 4/24/2013
Flow Control (incl. facility summary sheet)	Level: <input type="checkbox"/> 1 <input type="checkbox"/> 2 <input type="checkbox"/> 3 or Exemption Number <u>Q<sub>100</sub> increase &lt; 0.1 cfs</u> Small Site BMPs N/A
Conveyance System	Spill containment located at: N/A
Erosion and Sediment Control	ESC Site Supervisor: Craig Buitrago Contact Phone: 206-394-3700 After Hours Phone: 206-394-3700

**TECHNICAL INFORMATION REPORT (TIR) WORKSHEET**

Maintenance and Operation Responsibility:  Private  Public  
 If Private, Maintenance Log Required:  Yes  No

Financial Guarantees and Liability Provided:  Yes  No

Water Quality (include facility summary sheet) Type:  Basic  Sens. Lake  Enhanced Basic  Bog  
 Or Exemption No. 1, Surface Area Exemption  
 Landscape Management Plan:  Yes  No

**Special Requirements (as applicable)**

Area Specific Drainage Requirements Type:  CDA  SDO  MDP  BP  Shared Fac.  None  
 Name:

Floodplain/Floodway Delineation Type:  Major  Minor  Exemption  None  
 100- year Base Flood Elevation (or range): 36.57  
 Datum: NAVD 88

Flood Protection Facilities Describe: N/A

Source Control (comm./ industrial landuse) Describe: N/A  
 Describe any structural controls: N/A

Oil Control High-use Site:  Yes  No  
 Treatment BMP: N/A  
 Maintenance Agreement:  Yes  No  
 With whom? N/A

**Other Drainage Structures**

Describe:

**Threshold Discharge Area**

(name or description): TDA 46: Station 406+68 to 408+15

**Core Requirements (all 8 apply)**

Discharge at Natural Location Number of Natural Discharge Locations: 1

Offsite Analysis: Level:  1  2  3 Dated: 4/16/2013 and 4/24/2013

Flow Control (incl. facility summary sheet) Level:  1  2  3 or Exemption Number Q<sub>100</sub> increase < 0.1 cfs  
 Small Site BMPs N/A

Conveyance System Spill containment located at: N/A

Erosion and Sediment Control ESC Site Supervisor: Craig Buitrago  
 Contact Phone: 206-394-3700  
 After Hours Phone: 206-394-3700

Maintenance and Operation Responsibility:  Private  Public  
 If Private, Maintenance Log Required:  Yes  No

Financial Guarantees and Liability Provided:  Yes  No

Water Quality (include facility summary sheet) Type:  Basic  Sens. Lake  Enhanced Basic  Bog  
 Or Exemption No. 1, Surface Area Exemption  
 Landscape Management Plan:  Yes  No

**Special Requirements (as applicable)**

Area Specific Drainage Requirements Type:  CDA  SDO  MDP  BP  Shared Fac.  None  
 Name:

Floodplain/Floodway Delineation Type:  Major  Minor  Exemption  None  
 100- year Base Flood Elevation (or range): 36.57

**TECHNICAL INFORMATION REPORT (TIR) WORKSHEET**

	Datum: NAVD 88
Flood Protection Facilities	Describe: N/A
Source Control (comm./ industrial landuse)	Describe: N/A Describe any structural controls: N/A
Oil Control	High-use Site: <input type="checkbox"/> Yes <input checked="" type="checkbox"/> No Treatment BMP: N/A Maintenance Agreement: <input type="checkbox"/> Yes <input checked="" type="checkbox"/> No With whom? N/A
<b>Other Drainage Structures</b>	
Describe:	

<b>Threshold Discharge Area</b> (name or description): <b>TDA 47: Station 408+15 to 413+30</b>	
<b>Core Requirements (all 8 apply)</b>	
Discharge at Natural Location	Number of Natural Discharge Locations: 1
Offsite Analysis:	Level: <input checked="" type="checkbox"/> 1 <input type="checkbox"/> 2 <input type="checkbox"/> 3      Dated: 4/16/2013 and 4/24/2013
Flow Control (incl. facility summary sheet)	Level: <input type="checkbox"/> 1 <input type="checkbox"/> 2 <input type="checkbox"/> 3      or Exemption Number <u>Q<sub>100</sub> increase &lt; 0.1 cfs</u> Small Site BMPs N/A
Conveyance System	Spill containment located at: N/A
Erosion and Sediment Control	ESC Site Supervisor: Craig Buitrago Contact Phone: 206-394-3700 After Hours Phone: 206-394-3700
Maintenance and Operation	Responsibility: <input type="checkbox"/> Private <input checked="" type="checkbox"/> Public If Private, Maintenance Log Required: <input type="checkbox"/> Yes <input type="checkbox"/> No
Financial Guarantees and Liability	Provided: <input type="checkbox"/> Yes <input checked="" type="checkbox"/> No
Water Quality (include facility summary sheet)	Type: <input type="checkbox"/> Basic <input type="checkbox"/> Sens. Lake <input type="checkbox"/> Enhanced Basic <input type="checkbox"/> Bog Or Exemption No. 1, Surface Area Exemption Landscape Management Plan: <input checked="" type="checkbox"/> Yes <input type="checkbox"/> No
<b>Special Requirements (as applicable)</b>	
Area Specific Drainage Requirements	Type: <input type="checkbox"/> CDA <input type="checkbox"/> SDO <input type="checkbox"/> MDP <input type="checkbox"/> BP <input type="checkbox"/> Shared Fac. <input checked="" type="checkbox"/> None Name:
Floodplain/Floodway Delineation	Type: <input type="checkbox"/> Major <input type="checkbox"/> Minor <input checked="" type="checkbox"/> Exemption <input type="checkbox"/> None 100- year Base Flood Elevation (or range): 36.57 Datum: NAVD 88
Flood Protection Facilities	Describe: N/A
Source Control (comm./ industrial landuse)	Describe: N/A Describe any structural controls: N/A
Oil Control	High-use Site: <input type="checkbox"/> Yes <input checked="" type="checkbox"/> No Treatment BMP: N/A Maintenance Agreement: <input type="checkbox"/> Yes <input checked="" type="checkbox"/> No With whom? N/A
<b>Other Drainage Structures</b>	
Describe:	

**TECHNICAL INFORMATION REPORT (TIR) WORKSHEET**

**Threshold Discharge Area**

(name or description): TDA 48: Station 413+30 to 418+60

**Core Requirements (all 8 apply)**

Discharge at Natural Location	Number of Natural Discharge Locations: 1
Offsite Analysis:	Level: <input checked="" type="checkbox"/> 1 <input type="checkbox"/> 2 <input type="checkbox"/> 3 Dated: 4/16/2013 and 4/24/2013
Flow Control (incl. facility summary sheet)	Level: <input type="checkbox"/> 1 <input type="checkbox"/> 2 <input type="checkbox"/> 3 or Exemption Number <u>Basic Dispersion</u> Small Site BMPs N/A
Conveyance System	Spill containment located at: N/A
Erosion and Sediment Control	ESC Site Supervisor: Craig Buitrago Contact Phone: 206-394-3700 After Hours Phone: 206-394-3700
Maintenance and Operation	Responsibility: <input type="checkbox"/> Private <input checked="" type="checkbox"/> Public If Private, Maintenance Log Required: <input type="checkbox"/> Yes <input type="checkbox"/> No
Financial Guarantees and Liability	Provided: <input type="checkbox"/> Yes <input checked="" type="checkbox"/> No
Water Quality (include facility summary sheet)	Type: <input type="checkbox"/> Basic <input type="checkbox"/> Sens. Lake <input type="checkbox"/> Enhanced Basic <input type="checkbox"/> Bog Or Exemption No. 1, Surface Area Exemption Landscape Management Plan: <input checked="" type="checkbox"/> Yes <input type="checkbox"/> No

**Special Requirements (as applicable)**

Area Specific Drainage Requirements	Type: <input type="checkbox"/> CDA <input type="checkbox"/> SDO <input type="checkbox"/> MDP <input type="checkbox"/> BP <input type="checkbox"/> Shared Fac. <input checked="" type="checkbox"/> None Name:
Floodplain/Floodway Delineation	Type: <input type="checkbox"/> Major <input type="checkbox"/> Minor <input checked="" type="checkbox"/> Exemption <input type="checkbox"/> None 100- year Base Flood Elevation (or range): 36.57 Datum: NAVD 88
Flood Protection Facilities	Describe: N/A
Source Control (comm./ industrial landuse)	Describe: N/A Describe any structural controls: N/A
Oil Control	High-use Site: <input type="checkbox"/> Yes <input checked="" type="checkbox"/> No Treatment BMP: N/A Maintenance Agreement: <input type="checkbox"/> Yes <input checked="" type="checkbox"/> No With whom? N/A

**Other Drainage Structures**

Describe:

**Threshold Discharge Area**

(name or description): TDA 49: Station 419+05 to 424+20

**Core Requirements (all 8 apply)**

Discharge at Natural Location	Number of Natural Discharge Locations: 1
Offsite Analysis:	Level: <input checked="" type="checkbox"/> 1 <input type="checkbox"/> 2 <input type="checkbox"/> 3 Dated: 4/16/2013 and 4/24/2013
Flow Control (incl. facility summary sheet)	Level: <input type="checkbox"/> 1 <input type="checkbox"/> 2 <input type="checkbox"/> 3 or Exemption Number <u>Basic Dispersion</u> Small Site BMPs N/A
Conveyance System	Spill containment located at: N/A
Erosion and Sediment Control	ESC Site Supervisor: Craig Buitrago Contact Phone: 206-394-3700 After Hours Phone: 206-394-3700

**TECHNICAL INFORMATION REPORT (TIR) WORKSHEET**

Maintenance and Operation Responsibility:  Private  Public  
 If Private, Maintenance Log Required:  Yes  No

Financial Guarantees and Liability Provided:  Yes  No

Water Quality (include facility summary sheet) Type:  Basic  Sens. Lake  Enhanced Basic  Bog  
 Or Exemption No. 1, Surface Area Exemption  
 Landscape Management Plan:  Yes  No

**Special Requirements (as applicable)**

Area Specific Drainage Requirements Type:  CDA  SDO  MDP  BP  Shared Fac.  None  
 Name:

Floodplain/Floodway Delineation Type:  Major  Minor  Exemption  None  
 100- year Base Flood Elevation (or range): 36.57  
 Datum: NAVD 88

Flood Protection Facilities Describe: N/A

Source Control (comm./ industrial landuse) Describe: N/A  
 Describe any structural controls: N/A

Oil Control High-use Site:  Yes  No  
 Treatment BMP: N/A  
 Maintenance Agreement:  Yes  No  
 With whom? N/A

**Other Drainage Structures**

Describe:

**Threshold Discharge Area**

(name or description): TDA 50: Station 424+20 to 424+75

**Core Requirements (all 8 apply)**

Discharge at Natural Location Number of Natural Discharge Locations: 1

Offsite Analysis: Level:  1  2  3 Dated: 4/16/2013 and 4/24/2013

Flow Control (incl. facility summary sheet) Level:  1  2  3 or Exemption Number Q<sub>100</sub> increase < 0.1 cfs  
 Small Site BMPs N/A

Conveyance System Spill containment located at: N/A

Erosion and Sediment Control ESC Site Supervisor: Craig Buitrago  
 Contact Phone: 206-394-3700  
 After Hours Phone: 206-394-3700

Maintenance and Operation Responsibility:  Private  Public  
 If Private, Maintenance Log Required:  Yes  No

Financial Guarantees and Liability Provided:  Yes  No

Water Quality (include facility summary sheet) Type:  Basic  Sens. Lake  Enhanced Basic  Bog  
 Or Exemption No. 1, Surface Area Exemption  
 Landscape Management Plan:  Yes  No

**Special Requirements (as applicable)**

Area Specific Drainage Requirements Type:  CDA  SDO  MDP  BP  Shared Fac.  None  
 Name:

Floodplain/Floodway Delineation Type:  Major  Minor  Exemption  None  
 100- year Base Flood Elevation (or range): 36.57

**TECHNICAL INFORMATION REPORT (TIR) WORKSHEET**

	Datum: NAVD 88
Flood Protection Facilities	Describe: N/A
Source Control (comm./ industrial landuse)	Describe: N/A Describe any structural controls: N/A
Oil Control	High-use Site: <input type="checkbox"/> Yes <input checked="" type="checkbox"/> No Treatment BMP: N/A Maintenance Agreement: <input type="checkbox"/> Yes <input checked="" type="checkbox"/> No With whom? N/A
<b>Other Drainage Structures</b>	
Describe:	
<b>Threshold Discharge Area</b>	
(name or description):	TDA 51: Station 424+75 to 426+35
<b>Core Requirements (all 8 apply)</b>	
Discharge at Natural Location	Number of Natural Discharge Locations: 1
Offsite Analysis:	Level: <input checked="" type="checkbox"/> 1 <input type="checkbox"/> 2 <input type="checkbox"/> 3 Dated: 4/16/2013 and 4/24/2013
Flow Control (incl. facility summary sheet)	Level: <input type="checkbox"/> 1 <input type="checkbox"/> 2 <input type="checkbox"/> 3 or Exemption Number <u>Q<sub>100</sub> increase &lt; 0.1 cfs</u> Small Site BMPs N/A
Conveyance System	Spill containment located at: N/A
Erosion and Sediment Control	ESC Site Supervisor: Craig Buitrago Contact Phone: 206-394-3700 After Hours Phone: 206-394-3700
Maintenance and Operation	Responsibility: <input type="checkbox"/> Private <input checked="" type="checkbox"/> Public If Private, Maintenance Log Required: <input type="checkbox"/> Yes <input type="checkbox"/> No
Financial Guarantees and Liability	Provided: <input type="checkbox"/> Yes <input checked="" type="checkbox"/> No
Water Quality (include facility summary sheet)	Type: <input type="checkbox"/> Basic <input type="checkbox"/> Sens. Lake <input type="checkbox"/> Enhanced Basic <input type="checkbox"/> Bog Or Exemption No. 1, Surface Area Exemption Landscape Management Plan: <input checked="" type="checkbox"/> Yes <input type="checkbox"/> No
<b>Special Requirements (as applicable)</b>	
Area Specific Drainage Requirements	Type: <input type="checkbox"/> CDA <input type="checkbox"/> SDO <input type="checkbox"/> MDP <input type="checkbox"/> BP <input type="checkbox"/> Shared Fac. <input checked="" type="checkbox"/> None Name:
Floodplain/Floodway Delineation	Type: <input type="checkbox"/> Major <input type="checkbox"/> Minor <input checked="" type="checkbox"/> Exemption <input type="checkbox"/> None 100- year Base Flood Elevation (or range): 36.57 Datum: NAVD 88
Flood Protection Facilities	Describe: N/A
Source Control (comm./ industrial landuse)	Describe: N/A Describe any structural controls: N/A
Oil Control	High-use Site: <input type="checkbox"/> Yes <input checked="" type="checkbox"/> No Treatment BMP: N/A Maintenance Agreement: <input type="checkbox"/> Yes <input checked="" type="checkbox"/> No With whom? N/A
<b>Other Drainage Structures</b>	
Describe:	

**TECHNICAL INFORMATION REPORT (TIR) WORKSHEET**

**Threshold Discharge Area**

(name or description): TDA 52: Station 426+35 to 431+70

**Core Requirements (all 8 apply)**

Discharge at Natural Location	Number of Natural Discharge Locations: 1
Offsite Analysis:	Level: <input checked="" type="checkbox"/> 1 <input type="checkbox"/> 2 <input type="checkbox"/> 3 Dated: 4/16/2013 and 4/24/2013
Flow Control (incl. facility summary sheet)	Level: <input type="checkbox"/> 1 <input type="checkbox"/> 2 <input type="checkbox"/> 3 or Exemption Number <u>Basic Dispersion</u> Small Site BMPs N/A
Conveyance System	Spill containment located at: N/A
Erosion and Sediment Control	ESC Site Supervisor: Craig Buitrago Contact Phone: 206-394-3700 After Hours Phone: 206-394-3700
Maintenance and Operation	Responsibility: <input type="checkbox"/> Private <input checked="" type="checkbox"/> Public If Private, Maintenance Log Required: <input type="checkbox"/> Yes <input type="checkbox"/> No
Financial Guarantees and Liability	Provided: <input type="checkbox"/> Yes <input checked="" type="checkbox"/> No
Water Quality (include facility summary sheet)	Type: <input type="checkbox"/> Basic <input type="checkbox"/> Sens. Lake <input type="checkbox"/> Enhanced Basic <input type="checkbox"/> Bog Or Exemption No. 1, Surface Area Exemption Landscape Management Plan: <input checked="" type="checkbox"/> Yes <input type="checkbox"/> No

**Special Requirements (as applicable)**

Area Specific Drainage Requirements	Type: <input type="checkbox"/> CDA <input type="checkbox"/> SDO <input type="checkbox"/> MDP <input type="checkbox"/> BP <input type="checkbox"/> Shared Fac. <input checked="" type="checkbox"/> None Name:
Floodplain/Floodway Delineation	Type: <input type="checkbox"/> Major <input type="checkbox"/> Minor <input checked="" type="checkbox"/> Exemption <input type="checkbox"/> None 100- year Base Flood Elevation (or range): 36.57 Datum: NAVD 88
Flood Protection Facilities	Describe: N/A
Source Control (comm./ industrial landuse)	Describe: N/A Describe any structural controls: N/A
Oil Control	High-use Site: <input type="checkbox"/> Yes <input checked="" type="checkbox"/> No Treatment BMP: N/A Maintenance Agreement: <input type="checkbox"/> Yes <input checked="" type="checkbox"/> No With whom? N/A

**Other Drainage Structures**

Describe:

**Threshold Discharge Area**

(name or description): TDA 53: Station 431+70 to 434+50

**Core Requirements (all 8 apply)**

Discharge at Natural Location	Number of Natural Discharge Locations: 1
Offsite Analysis:	Level: <input checked="" type="checkbox"/> 1 <input type="checkbox"/> 2 <input type="checkbox"/> 3 Dated: 4/16/2013 and 4/24/2013
Flow Control (incl. facility summary sheet)	Level: <input type="checkbox"/> 1 <input type="checkbox"/> 2 <input type="checkbox"/> 3 or Exemption Number <u>Q<sub>100</sub> increase &lt; 0.1 cfs</u> Small Site BMPs N/A
Conveyance System	Spill containment located at: N/A
Erosion and Sediment Control	ESC Site Supervisor: Craig Buitrago Contact Phone: 206-394-3700 After Hours Phone: 206-394-3700



**TECHNICAL INFORMATION REPORT (TIR) WORKSHEET**

Maintenance and Operation Responsibility:  Private  Public  
 If Private, Maintenance Log Required:  Yes  No

Financial Guarantees and Liability Provided:  Yes  No

Water Quality (include facility summary sheet) Type:  Basic  Sens. Lake  Enhanced Basic  Bog  
 Or Exemption No. 1, Surface Area Exemption  
 Landscape Management Plan:  Yes  No

**Special Requirements (as applicable)**

Area Specific Drainage Requirements Type:  CDA  SDO  MDP  BP  Shared Fac.  None  
 Name:

Floodplain/Floodway Delineation Type:  Major  Minor  Exemption  None  
 100- year Base Flood Elevation (or range): 36.57  
 Datum: NAVD 88

Flood Protection Facilities Describe: N/A

Source Control (comm./ industrial landuse) Describe: N/A  
 Describe any structural controls: N/A

Oil Control High-use Site:  Yes  No  
 Treatment BMP: N/A  
 Maintenance Agreement:  Yes  No  
 With whom? N/A

**Other Drainage Structures**

Describe:

**Threshold Discharge Area**

(name or description): TDA 54: Station 434+50 to 441+10

**Core Requirements (all 8 apply)**

Discharge at Natural Location Number of Natural Discharge Locations: 1

Offsite Analysis: Level:  1  2  3 Dated: 4/16/2013 and 4/24/2013

Flow Control (incl. facility summary sheet) Level:  1  2  3 or Exemption Number Q<sub>100</sub> increase < 0.1 cfs  
 Small Site BMPs N/A

Conveyance System Spill containment located at: N/A

Erosion and Sediment Control ESC Site Supervisor: Craig Buitrago  
 Contact Phone: 206-394-3700  
 After Hours Phone: 206-394-3700

Maintenance and Operation Responsibility:  Private  Public  
 If Private, Maintenance Log Required:  Yes  No

Financial Guarantees and Liability Provided:  Yes  No

Water Quality (include facility summary sheet) Type:  Basic  Sens. Lake  Enhanced Basic  Bog  
 Or Exemption No. 1, Surface Area Exemption  
 Landscape Management Plan:  Yes  No

**Special Requirements (as applicable)**

Area Specific Drainage Requirements Type:  CDA  SDO  MDP  BP  Shared Fac.  None  
 Name:

Floodplain/Floodway Delineation Type:  Major  Minor  Exemption  None  
 100- year Base Flood Elevation (or range): 36.57

**TECHNICAL INFORMATION REPORT (TIR) WORKSHEET**

	Datum: NAVD 88
Flood Protection Facilities	Describe: N/A
Source Control (comm./ industrial landuse)	Describe: N/A Describe any structural controls: N/A
Oil Control	High-use Site: <input type="checkbox"/> Yes <input checked="" type="checkbox"/> No Treatment BMP: N/A Maintenance Agreement: <input type="checkbox"/> Yes <input checked="" type="checkbox"/> No With whom? N/A
<b>Other Drainage Structures</b>	
Describe:	

<b>Threshold Discharge Area</b>	
(name or description):	TDA 55: Station 441+10 to 444+30
<b>Core Requirements (all 8 apply)</b>	
Discharge at Natural Location	Number of Natural Discharge Locations: 1
Offsite Analysis:	Level: <input checked="" type="checkbox"/> 1 <input type="checkbox"/> 2 <input type="checkbox"/> 3 Dated: 4/16/2013 and 4/24/2013
Flow Control (incl. facility summary sheet)	Level: <input type="checkbox"/> 1 <input type="checkbox"/> 2 <input type="checkbox"/> 3 or Exemption Number <u>Q<sub>100</sub> increase &lt; 0.1 cfs</u> Small Site BMPs N/A
Conveyance System	Spill containment located at: N/A
Erosion and Sediment Control	ESC Site Supervisor: Craig Buitrago Contact Phone: 206-394-3700 After Hours Phone: 206-394-3700
Maintenance and Operation	Responsibility: <input type="checkbox"/> Private <input checked="" type="checkbox"/> Public If Private, Maintenance Log Required: <input type="checkbox"/> Yes <input type="checkbox"/> No
Financial Guarantees and Liability	Provided: <input type="checkbox"/> Yes <input checked="" type="checkbox"/> No
Water Quality (include facility summary sheet)	Type: <input type="checkbox"/> Basic <input type="checkbox"/> Sens. Lake <input type="checkbox"/> Enhanced Basic <input type="checkbox"/> Bog Or Exemption No. 1, Surface Area Exemption Landscape Management Plan: <input checked="" type="checkbox"/> Yes <input type="checkbox"/> No
<b>Special Requirements (as applicable)</b>	
Area Specific Drainage Requirements	Type: <input type="checkbox"/> CDA <input type="checkbox"/> SDO <input type="checkbox"/> MDP <input type="checkbox"/> BP <input type="checkbox"/> Shared Fac. <input checked="" type="checkbox"/> None Name:
Floodplain/Floodway Delineation	Type: <input type="checkbox"/> Major <input type="checkbox"/> Minor <input checked="" type="checkbox"/> Exemption <input type="checkbox"/> None 100- year Base Flood Elevation (or range): 36.57 Datum: NAVD 88
Flood Protection Facilities	Describe: N/A
Source Control (comm./ industrial landuse)	Describe: N/A Describe any structural controls: N/A
Oil Control	High-use Site: <input type="checkbox"/> Yes <input checked="" type="checkbox"/> No Treatment BMP: N/A Maintenance Agreement: <input type="checkbox"/> Yes <input checked="" type="checkbox"/> No With whom? N/A
<b>Other Drainage Structures</b>	
Describe:	

**TECHNICAL INFORMATION REPORT (TIR) WORKSHEET**

**Threshold Discharge Area**

(name or description): TDA 56: Station 444+30 to 448+66

**Core Requirements (all 8 apply)**

Discharge at Natural Location	Number of Natural Discharge Locations: 1
Offsite Analysis:	Level: <input checked="" type="checkbox"/> 1 <input type="checkbox"/> 2 <input type="checkbox"/> 3 Dated: 4/16/2013 and 4/24/2013
Flow Control (incl. facility summary sheet)	Level: <input type="checkbox"/> 1 <input type="checkbox"/> 2 <input type="checkbox"/> 3 or Exemption Number <u>Q<sub>100</sub> increase &lt; 0.1 cfs</u> Small Site BMPs N/A
Conveyance System	Spill containment located at: N/A
Erosion and Sediment Control	ESC Site Supervisor: Craig Buitrago Contact Phone: 206-394-3700 After Hours Phone: 206-394-3700
Maintenance and Operation	Responsibility: <input type="checkbox"/> Private <input checked="" type="checkbox"/> Public If Private, Maintenance Log Required: <input type="checkbox"/> Yes <input type="checkbox"/> No
Financial Guarantees and Liability	Provided: <input type="checkbox"/> Yes <input checked="" type="checkbox"/> No
Water Quality (include facility summary sheet)	Type: <input type="checkbox"/> Basic <input type="checkbox"/> Sens. Lake <input type="checkbox"/> Enhanced Basic <input type="checkbox"/> Bog Or Exemption No. 1, Surface Area Exemption Landscape Management Plan: <input checked="" type="checkbox"/> Yes <input type="checkbox"/> No

**Special Requirements (as applicable)**

Area Specific Drainage Requirements	Type: <input type="checkbox"/> CDA <input type="checkbox"/> SDO <input type="checkbox"/> MDP <input type="checkbox"/> BP <input type="checkbox"/> Shared Fac. <input checked="" type="checkbox"/> None Name:
Floodplain/Floodway Delineation	Type: <input type="checkbox"/> Major <input type="checkbox"/> Minor <input checked="" type="checkbox"/> Exemption <input type="checkbox"/> None 100- year Base Flood Elevation (or range): 36.57 Datum: NAVD 88
Flood Protection Facilities	Describe: N/A
Source Control (comm./ industrial landuse)	Describe: N/A Describe any structural controls: N/A
Oil Control	High-use Site: <input type="checkbox"/> Yes <input checked="" type="checkbox"/> No Treatment BMP: N/A Maintenance Agreement: <input type="checkbox"/> Yes <input checked="" type="checkbox"/> No With whom? N/A

**Other Drainage Structures**

Describe:

**Threshold Discharge Area**

(name or description): TDA 57: Station 448+66 to 450+70

**Core Requirements (all 8 apply)**

Discharge at Natural Location	Number of Natural Discharge Locations: 1
Offsite Analysis:	Level: <input checked="" type="checkbox"/> 1 <input type="checkbox"/> 2 <input type="checkbox"/> 3 Dated: 4/16/2013 and 4/24/2013
Flow Control (incl. facility summary sheet)	Level: <input type="checkbox"/> 1 <input type="checkbox"/> 2 <input type="checkbox"/> 3 or Exemption Number <u>Q<sub>100</sub> increase &lt; 0.1 cfs</u> Small Site BMPs N/A
Conveyance System	Spill containment located at: N/A
Erosion and Sediment Control	ESC Site Supervisor: Craig Buitrago Contact Phone: 206-394-3700 After Hours Phone: 206-394-3700

**TECHNICAL INFORMATION REPORT (TIR) WORKSHEET**

Maintenance and Operation Responsibility:  Private  Public  
 If Private, Maintenance Log Required:  Yes  No

Financial Guarantees and Liability Provided:  Yes  No

Water Quality (include facility summary sheet) Type:  Basic  Sens. Lake  Enhanced Basic  Bog  
 Or Exemption No. 1, Surface Area Exemption  
 Landscape Management Plan:  Yes  No

**Special Requirements (as applicable)**

Area Specific Drainage Requirements Type:  CDA  SDO  MDP  BP  Shared Fac.  None  
 Name:

Floodplain/Floodway Delineation Type:  Major  Minor  Exemption  None  
 100- year Base Flood Elevation (or range): 36.57  
 Datum: NAVD 88

Flood Protection Facilities Describe: N/A

Source Control (comm./ industrial landuse) Describe: N/A  
 Describe any structural controls: N/A

Oil Control High-use Site:  Yes  No  
 Treatment BMP: N/A  
 Maintenance Agreement:  Yes  No  
 With whom? N/A

**Other Drainage Structures**

Describe:

**Threshold Discharge Area**

(name or description): **TDA 58: Station 450+70 to 453+95**

**Core Requirements (all 8 apply)**

Discharge at Natural Location Number of Natural Discharge Locations: 1

Offsite Analysis: Level:  1  2  3 Dated: 4/16/2013 and 4/24/2013

Flow Control (incl. facility summary sheet) Level:  1  2  3 or Exemption Number Q<sub>100</sub> increase < 0.1 cfs  
 Small Site BMPs N/A

Conveyance System Spill containment located at: N/A

Erosion and Sediment Control ESC Site Supervisor: Craig Buitrago  
 Contact Phone: 206-394-3700  
 After Hours Phone: 206-394-3700

Maintenance and Operation Responsibility:  Private  Public  
 If Private, Maintenance Log Required:  Yes  No

Financial Guarantees and Liability Provided:  Yes  No

Water Quality (include facility summary sheet) Type:  Basic  Sens. Lake  Enhanced Basic  Bog  
 Or Exemption No. 1, Surface Area Exemption  
 Landscape Management Plan:  Yes  No

**Special Requirements (as applicable)**

Area Specific Drainage Requirements Type:  CDA  SDO  MDP  BP  Shared Fac.  None  
 Name:

Floodplain/Floodway Delineation Type:  Major  Minor  Exemption  None  
 100- year Base Flood Elevation (or range): 36.57

**TECHNICAL INFORMATION REPORT (TIR) WORKSHEET**

	Datum: NAVD 88
Flood Protection Facilities	Describe: N/A
Source Control (comm./ industrial landuse)	Describe: N/A Describe any structural controls: N/A
Oil Control	High-use Site: <input type="checkbox"/> Yes <input checked="" type="checkbox"/> No Treatment BMP: N/A Maintenance Agreement: <input type="checkbox"/> Yes <input checked="" type="checkbox"/> No With whom? N/A
<b>Other Drainage Structures</b>	
Describe:	

<b>Threshold Discharge Area</b>	
(name or description):	TDA 59: Station 453+95 to 454+65
<b>Core Requirements (all 8 apply)</b>	
Discharge at Natural Location	Number of Natural Discharge Locations: 1
Offsite Analysis:	Level: <input checked="" type="checkbox"/> 1 <input type="checkbox"/> 2 <input type="checkbox"/> 3      Dated: 4/16/2013 and 4/24/2013
Flow Control (incl. facility summary sheet)	Level: <input type="checkbox"/> 1 <input type="checkbox"/> 2 <input type="checkbox"/> 3      or Exemption Number <u>Q<sub>100</sub> increase &lt; 0.1 cfs</u> Small Site BMPs N/A
Conveyance System	Spill containment located at: N/A
Erosion and Sediment Control	ESC Site Supervisor: Craig Buitrago Contact Phone: 206-394-3700 After Hours Phone: 206-394-3700
Maintenance and Operation	Responsibility: <input type="checkbox"/> Private <input checked="" type="checkbox"/> Public If Private, Maintenance Log Required: <input type="checkbox"/> Yes <input type="checkbox"/> No
Financial Guarantees and Liability	Provided: <input type="checkbox"/> Yes <input checked="" type="checkbox"/> No
Water Quality (include facility summary sheet)	Type: <input type="checkbox"/> Basic <input type="checkbox"/> Sens. Lake <input type="checkbox"/> Enhanced Basic <input type="checkbox"/> Bog Or Exemption No. 1, Surface Area Exemption Landscape Management Plan: <input checked="" type="checkbox"/> Yes <input type="checkbox"/> No
<b>Special Requirements (as applicable)</b>	
Area Specific Drainage Requirements	Type: <input type="checkbox"/> CDA <input type="checkbox"/> SDO <input type="checkbox"/> MDP <input type="checkbox"/> BP <input type="checkbox"/> Shared Fac. <input checked="" type="checkbox"/> None Name:
Floodplain/Floodway Delineation	Type: <input type="checkbox"/> Major <input type="checkbox"/> Minor <input checked="" type="checkbox"/> Exemption <input type="checkbox"/> None 100- year Base Flood Elevation (or range): 36.57 Datum: NAVD 88
Flood Protection Facilities	Describe: N/A
Source Control (comm./ industrial landuse)	Describe: N/A Describe any structural controls: N/A
Oil Control	High-use Site: <input type="checkbox"/> Yes <input checked="" type="checkbox"/> No Treatment BMP: N/A Maintenance Agreement: <input type="checkbox"/> Yes <input checked="" type="checkbox"/> No With whom? N/A
<b>Other Drainage Structures</b>	
Describe:	

**TECHNICAL INFORMATION REPORT (TIR) WORKSHEET**

**Threshold Discharge Area**

(name or description): TDA 60: Station 454+65 to 458+50

**Core Requirements (all 8 apply)**

Discharge at Natural Location	Number of Natural Discharge Locations: 1
Offsite Analysis:	Level: <input checked="" type="checkbox"/> 1 <input type="checkbox"/> 2 <input type="checkbox"/> 3 Dated: 4/16/2013 and 4/24/2013
Flow Control (incl. facility summary sheet)	Level: <input type="checkbox"/> 1 <input type="checkbox"/> 2 <input type="checkbox"/> 3 or Exemption Number <u>Q<sub>100</sub> increase &lt; 0.1 cfs</u> Small Site BMPs N/A
Conveyance System	Spill containment located at: N/A
Erosion and Sediment Control	ESC Site Supervisor: Craig Buitrago Contact Phone: 206-394-3700 After Hours Phone: 206-394-3700
Maintenance and Operation	Responsibility: <input type="checkbox"/> Private <input checked="" type="checkbox"/> Public If Private, Maintenance Log Required: <input type="checkbox"/> Yes <input type="checkbox"/> No
Financial Guarantees and Liability	Provided: <input type="checkbox"/> Yes <input checked="" type="checkbox"/> No
Water Quality (include facility summary sheet)	Type: <input type="checkbox"/> Basic <input type="checkbox"/> Sens. Lake <input type="checkbox"/> Enhanced Basic <input type="checkbox"/> Bog Or Exemption No. 1, Surface Area Exemption Landscape Management Plan: <input checked="" type="checkbox"/> Yes <input type="checkbox"/> No

**Special Requirements (as applicable)**

Area Specific Drainage Requirements	Type: <input type="checkbox"/> CDA <input type="checkbox"/> SDO <input type="checkbox"/> MDP <input type="checkbox"/> BP <input type="checkbox"/> Shared Fac. <input checked="" type="checkbox"/> None Name:
Floodplain/Floodway Delineation	Type: <input type="checkbox"/> Major <input type="checkbox"/> Minor <input checked="" type="checkbox"/> Exemption <input type="checkbox"/> None 100- year Base Flood Elevation (or range): 36.57 Datum: NAVD 88
Flood Protection Facilities	Describe: N/A
Source Control (comm./ industrial landuse)	Describe: N/A Describe any structural controls: N/A
Oil Control	High-use Site: <input type="checkbox"/> Yes <input checked="" type="checkbox"/> No Treatment BMP: N/A Maintenance Agreement: <input type="checkbox"/> Yes <input checked="" type="checkbox"/> No With whom? N/A

**Other Drainage Structures**

Describe:

**Threshold Discharge Area**

(name or description): TDA 60A: Station 457+45 to 458+65

**Core Requirements (all 8 apply)**

Discharge at Natural Location	Number of Natural Discharge Locations: 1
Offsite Analysis:	Level: <input checked="" type="checkbox"/> 1 <input type="checkbox"/> 2 <input type="checkbox"/> 3 Dated: 4/16/2013 and 4/24/2013
Flow Control (incl. facility summary sheet)	Level: <input type="checkbox"/> 1 <input type="checkbox"/> 2 <input type="checkbox"/> 3 or Exemption Number <u>Q<sub>100</sub> increase &lt; 0.1 cfs</u> Small Site BMPs N/A
Conveyance System	Spill containment located at: N/A
Erosion and Sediment Control	ESC Site Supervisor: Craig Buitrago Contact Phone: 206-394-3700 After Hours Phone: 206-394-3700

**TECHNICAL INFORMATION REPORT (TIR) WORKSHEET**

Maintenance and Operation Responsibility:  Private  Public  
 If Private, Maintenance Log Required:  Yes  No

Financial Guarantees and Liability Provided:  Yes  No

Water Quality (include facility summary sheet) Type:  Basic  Sens. Lake  Enhanced Basic  Bog  
 Or Exemption No. 1, Surface Area Exemption  
 Landscape Management Plan:  Yes  No

**Special Requirements (as applicable)**

Area Specific Drainage Requirements Type:  CDA  SDO  MDP  BP  Shared Fac.  None  
 Name:

Floodplain/Floodway Delineation Type:  Major  Minor  Exemption  None  
 100- year Base Flood Elevation (or range): 36.57  
 Datum: NAVD 88

Flood Protection Facilities Describe: N/A

Source Control (comm./ industrial landuse) Describe: N/A  
 Describe any structural controls: N/A

Oil Control High-use Site:  Yes  No  
 Treatment BMP: N/A  
 Maintenance Agreement:  Yes  No  
 With whom? N/A

**Other Drainage Structures**

Describe:

**Threshold Discharge Area**

(name or description): TDA 61: Station 458+50 to 461+00

**Core Requirements (all 8 apply)**

Discharge at Natural Location Number of Natural Discharge Locations: 1

Offsite Analysis: Level:  1  2  3 Dated: 4/16/2013 and 4/24/2013

Flow Control (incl. facility summary sheet) Level:  1  2  3 or Exemption Number Q<sub>100</sub> increase < 0.1 cfs  
 Small Site BMPs N/A

Conveyance System Spill containment located at: N/A

Erosion and Sediment Control ESC Site Supervisor: Craig Buitrago  
 Contact Phone: 206-394-3700  
 After Hours Phone: 206-394-3700

Maintenance and Operation Responsibility:  Private  Public  
 If Private, Maintenance Log Required:  Yes  No

Financial Guarantees and Liability Provided:  Yes  No

Water Quality (include facility summary sheet) Type:  Basic  Sens. Lake  Enhanced Basic  Bog  
 Or Exemption No. 1, Surface Area Exemption  
 Landscape Management Plan:  Yes  No

**Special Requirements (as applicable)**

Area Specific Drainage Requirements Type:  CDA  SDO  MDP  BP  Shared Fac.  None  
 Name:

Floodplain/Floodway Delineation Type:  Major  Minor  Exemption  None  
 100- year Base Flood Elevation (or range): 36.57

**TECHNICAL INFORMATION REPORT (TIR) WORKSHEET**

	Datum: NAVD 88
Flood Protection Facilities	Describe: N/A
Source Control (comm./ industrial landuse)	Describe: N/A Describe any structural controls: N/A
Oil Control	High-use Site: <input type="checkbox"/> Yes <input checked="" type="checkbox"/> No Treatment BMP: N/A Maintenance Agreement: <input type="checkbox"/> Yes <input checked="" type="checkbox"/> No With whom? N/A
<b>Other Drainage Structures</b>	
Describe:	

<b>Threshold Discharge Area</b>	
(name or description):	TDA 62: Station 461+00 to 464+50
<b>Core Requirements (all 8 apply)</b>	
Discharge at Natural Location	Number of Natural Discharge Locations: 1
Offsite Analysis:	Level: <input checked="" type="checkbox"/> 1 <input type="checkbox"/> 2 <input type="checkbox"/> 3 Dated: 4/16/2013 and 4/24/2013
Flow Control (incl. facility summary sheet)	Level: <input type="checkbox"/> 1 <input type="checkbox"/> 2 <input type="checkbox"/> 3 or Exemption Number <u>Q<sub>100</sub> increase &lt; 0.1 cfs</u> Small Site BMPs N/A
Conveyance System	Spill containment located at: N/A
Erosion and Sediment Control	ESC Site Supervisor: Craig Buitrago Contact Phone: 206-394-3700 After Hours Phone: 206-394-3700
Maintenance and Operation	Responsibility: <input type="checkbox"/> Private <input checked="" type="checkbox"/> Public If Private, Maintenance Log Required: <input type="checkbox"/> Yes <input type="checkbox"/> No
Financial Guarantees and Liability	Provided: <input type="checkbox"/> Yes <input checked="" type="checkbox"/> No
Water Quality (include facility summary sheet)	Type: <input type="checkbox"/> Basic <input type="checkbox"/> Sens. Lake <input type="checkbox"/> Enhanced Basic <input type="checkbox"/> Bog Or Exemption No. 1, Surface Area Exemption Landscape Management Plan: <input checked="" type="checkbox"/> Yes <input type="checkbox"/> No
<b>Special Requirements (as applicable)</b>	
Area Specific Drainage Requirements	Type: <input type="checkbox"/> CDA <input type="checkbox"/> SDO <input type="checkbox"/> MDP <input type="checkbox"/> BP <input type="checkbox"/> Shared Fac. <input checked="" type="checkbox"/> None Name:
Floodplain/Floodway Delineation	Type: <input type="checkbox"/> Major <input type="checkbox"/> Minor <input checked="" type="checkbox"/> Exemption <input type="checkbox"/> None 100- year Base Flood Elevation (or range): 36.57 Datum: NAVD 88
Flood Protection Facilities	Describe: N/A
Source Control (comm./ industrial landuse)	Describe: N/A Describe any structural controls: N/A
Oil Control	High-use Site: <input type="checkbox"/> Yes <input checked="" type="checkbox"/> No Treatment BMP: N/A Maintenance Agreement: <input type="checkbox"/> Yes <input checked="" type="checkbox"/> No With whom? N/A
<b>Other Drainage Structures</b>	
Describe: Infiltration trench from STA 462+50 to 464+50	



**TECHNICAL INFORMATION REPORT (TIR) WORKSHEET**

**Threshold Discharge Area**

(name or description): TDA 63: Station 464+50 to 467+00

**Core Requirements (all 8 apply)**

Discharge at Natural Location	Number of Natural Discharge Locations: 1
Offsite Analysis:	Level: <input checked="" type="checkbox"/> 1 <input type="checkbox"/> 2 <input type="checkbox"/> 3 Dated: 4/16/2013 and 4/24/2013
Flow Control (incl. facility summary sheet)	Level: <input type="checkbox"/> 1 <input type="checkbox"/> 2 <input type="checkbox"/> 3 or Exemption Number <u>Q<sub>100</sub> increase &lt; 0.1 cfs</u> Small Site BMPs N/A
Conveyance System	Spill containment located at: N/A
Erosion and Sediment Control	ESC Site Supervisor: Craig Buitrago Contact Phone: 206-394-3700 After Hours Phone: 206-394-3700
Maintenance and Operation	Responsibility: <input type="checkbox"/> Private <input checked="" type="checkbox"/> Public If Private, Maintenance Log Required: <input type="checkbox"/> Yes <input type="checkbox"/> No
Financial Guarantees and Liability	Provided: <input type="checkbox"/> Yes <input checked="" type="checkbox"/> No
Water Quality (include facility summary sheet)	Type: <input type="checkbox"/> Basic <input type="checkbox"/> Sens. Lake <input type="checkbox"/> Enhanced Basic <input type="checkbox"/> Bog Or Exemption No. 1, Surface Area Exemption Landscape Management Plan: <input checked="" type="checkbox"/> Yes <input type="checkbox"/> No

**Special Requirements (as applicable)**

Area Specific Drainage Requirements	Type: <input type="checkbox"/> CDA <input type="checkbox"/> SDO <input type="checkbox"/> MDP <input type="checkbox"/> BP <input type="checkbox"/> Shared Fac. <input checked="" type="checkbox"/> None Name:
Floodplain/Floodway Delineation	Type: <input type="checkbox"/> Major <input type="checkbox"/> Minor <input checked="" type="checkbox"/> Exemption <input type="checkbox"/> None 100- year Base Flood Elevation (or range): 36.57 Datum: NAVD 88
Flood Protection Facilities	Describe: N/A
Source Control (comm./ industrial landuse)	Describe: N/A Describe any structural controls: N/A
Oil Control	High-use Site: <input type="checkbox"/> Yes <input checked="" type="checkbox"/> No Treatment BMP: N/A Maintenance Agreement: <input type="checkbox"/> Yes <input checked="" type="checkbox"/> No With whom? N/A

**Other Drainage Structures**

Describe:

**Threshold Discharge Area**

(name or description): TDA 64: Station 467+00 to 472+26

**Core Requirements (all 8 apply)**

Discharge at Natural Location	Number of Natural Discharge Locations: 1
Offsite Analysis:	Level: <input checked="" type="checkbox"/> 1 <input type="checkbox"/> 2 <input type="checkbox"/> 3 Dated: 4/16/2013 and 4/24/2013
Flow Control (incl. facility summary sheet)	Level: <input type="checkbox"/> 1 <input type="checkbox"/> 2 <input type="checkbox"/> 3 or Exemption Number <u>Q<sub>100</sub> increase &lt; 0.1 cfs</u> Small Site BMPs N/A
Conveyance System	Spill containment located at: N/A
Erosion and Sediment Control	ESC Site Supervisor: Craig Buitrago Contact Phone: 206-394-3700 After Hours Phone: 206-394-3700

**TECHNICAL INFORMATION REPORT (TIR) WORKSHEET**

Maintenance and Operation      Responsibility:  Private     Public  
 If Private, Maintenance Log Required:  Yes     No

Financial Guarantees and Liability      Provided:  Yes     No

Water Quality (include facility summary sheet)      Type:  Basic     Sens. Lake     Enhanced Basic     Bog  
 Or Exemption No. 1, Surface Area Exemption  
 Landscape Management Plan:  Yes     No

**Special Requirements (as applicable)**

Area Specific Drainage Requirements      Type:  CDA     SDO     MDP     BP     Shared Fac.     None  
 Name:

Floodplain/Floodway Delineation      Type:  Major     Minor     Exemption     None  
 100- year Base Flood Elevation (or range):    36.57  
 Datum:    NAVD 88

Flood Protection Facilities      Describe: N/A

Source Control (comm./ industrial landuse)      Describe: N/A  
 Describe any structural controls: N/A

Oil Control      High-use Site:  Yes     No  
 Treatment BMP: N/A  
 Maintenance Agreement:  Yes     No  
 With whom? N/A

**Other Drainage Structures**

Describe:

**TECHNICAL INFORMATION REPORT (TIR) WORKSHEET**

**PART 13 EROSION AND SEDIMENT CONTROL REQUIREMENTS**

MINIMUM ESC REQUIREMENTS DURING CONSTRUCTION	MINIMUM ESC REQUIREMENTS AFTER CONSTRUCTION
<input checked="" type="checkbox"/> Clearing Limits	<input checked="" type="checkbox"/> Stabilize Exposed Surfaces
<input checked="" type="checkbox"/> Cover Measures	<input checked="" type="checkbox"/> Remove and Restore Temporary ESC Facilities
<input checked="" type="checkbox"/> Perimeter Protection	<input checked="" type="checkbox"/> Clean and Remove All Silt and Debris, Ensure Operation of Permanent Facilities
<input checked="" type="checkbox"/> Traffic Area Stabilization	<input checked="" type="checkbox"/> Flag Limits of SAO and open space preservation areas
<input checked="" type="checkbox"/> Sediment Retention	<input type="checkbox"/> Other
<input type="checkbox"/> Surface Water Collection	
<input checked="" type="checkbox"/> Dewatering Control	
<input checked="" type="checkbox"/> Dust Control	
<input type="checkbox"/> Flow Control	

**PART 14 STORMWATER FACILITY DESCRIPTIONS (NOTE: INCLUDE FACILITY SUMMARY AND SKETCH)**

Flow Control	Type/Description	Water Quality	Type/Description
<input type="checkbox"/> Detention	_____	<input type="checkbox"/> Biofiltration	_____
<input checked="" type="checkbox"/> Infiltration	Infiltration Chamber and Infiltration Trench	<input type="checkbox"/> Wetpool	_____
<input type="checkbox"/> Regional Facility	_____	<input type="checkbox"/> Media Filtration	_____
<input type="checkbox"/> Shared Facility	_____	<input type="checkbox"/> Oil Control	_____
<input checked="" type="checkbox"/> Flow Control BMPs	Infiltration Trenches, Basic Dispersion	<input type="checkbox"/> Spill Control	_____
<input type="checkbox"/> Other	_____	<input type="checkbox"/> Flow Control BMPs	_____
		<input type="checkbox"/> Other	_____

**PART 15 EASEMENTS/TRACTS**

<input checked="" type="checkbox"/> Drainage Easement
<input type="checkbox"/> Covenant
<input type="checkbox"/> Native Growth Protection Covenant
<input type="checkbox"/> Tract
<input type="checkbox"/> Other

**PART 16 STRUCTURAL ANALYSIS**

<input type="checkbox"/> Cast in Place Vault
<input checked="" type="checkbox"/> Retaining Wall
<input type="checkbox"/> Rockery > 4' High
<input type="checkbox"/> Structural on Steep Slope
<input type="checkbox"/> Other

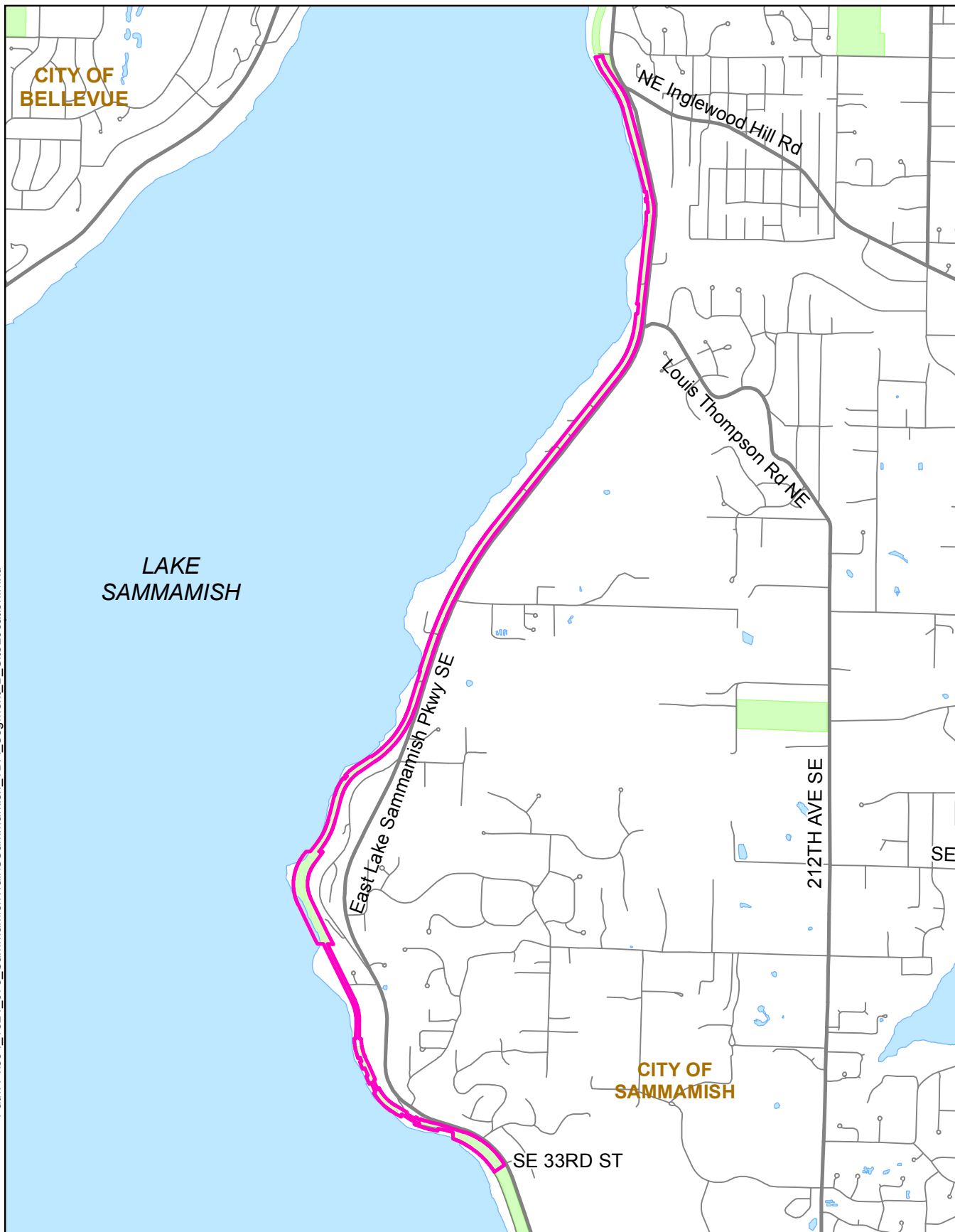
**PART 17 EASEMENTS/TRACTS**

I, or a civil engineer under my supervision, have visited the site. Actual site conditions as observed were incorporated into this worksheet and the attached Technical information Report. To the best of my knowledge the information provided here is accurate.

Signed/Date



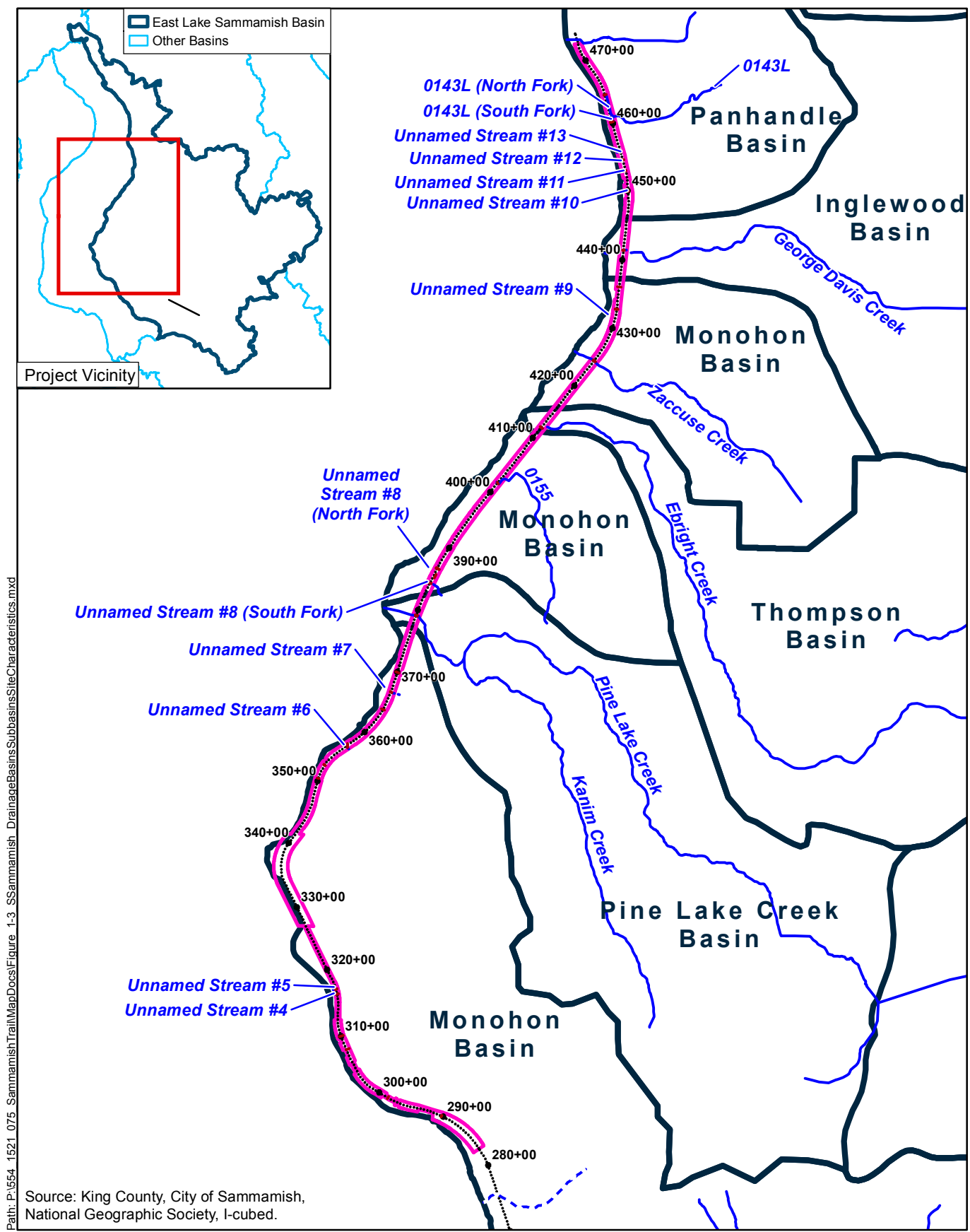
Path: P:\554\_1521\_075\_SammamishTrail\SSammamish\_TDA\_Segment\_B\_SiteLocation.mxd



 Project Location

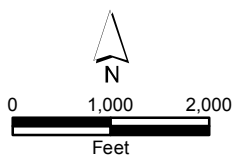
**Figure 1-2**  
**Site Location Map**  
**East Lake Sammamish Trail**  
**South Sammamish - Segment B**





Path: P:\954\_1521\_075\_Sammamish\TrailMapDocs\Figure\_1-3\_Sammamish\_DrainageBasinsSubbasinsSiteCharacteristics.mxd

Source: King County, City of Sammamish, National Geographic Society, I-cubed.



- ▭ South Sammamish Segment B Project Location
- Stream Crossing Field-verified by Parametrix
- - - Stream Crossing Not Found within Trail Corridor
- City of Sammamish Drainage Basin

- 480+00      485+00
- ● ● ● ●
- Proposed Trail Stationing

**Figure 1-3  
Drainage Basins,  
Subbasins, and Site  
Characteristics**





### 1.3 Project Area Soils

Natural Resources Conservation Service (NRCS) soil maps were used to show the existing soils within the project corridor. Figure 1-4 depicts the soils by type and hydrologic group throughout the project corridor. The corridor consists of a mix of all soil types with the primary soil groups consisting of Hydrologic Groups A and B, with lesser areas of Groups C and D.

City of Sammamish Environmentally Sensitive Areas Geologic Hazards map was used to identify the erosion and landslide hazard areas within the project corridor and upland areas. The erosion hazard areas occur when underlying soils types like EvD and KpD are combined with slopes steeper than 15 percent. Landslide hazard areas are typically susceptible to landslide because of a combination of factors including: bedrock, soil, slope gradient, slope aspect, geologic structure, groundwater, or other factors. Figure 1-5 depicts the geologic hazards in the project vicinity. There are erosion and landslide hazard areas present in the project area from approximately Station 325+00 to 370+00 and landslide hazard areas present from approximately Station 435+00 to Station 445+00.

A geotechnical survey was completed by Icicle Creek Engineers, Inc. and their draft report dated October 2016. Parametrix engineers used the information in the geotechnical report to design retaining walls and infiltration facilities. Soil boring tests were performed throughout the project site, and single-ring infiltrometer test (SRIT) was performed at locations where infiltration trenches were thought to be desirable. The test results found that infiltration is feasible in some areas of the corridor, and the infiltration rates in those areas are high because of the relatively gravelly sandy soils. Areas where infiltration will be used for flow control are discussed in Section 4.4.

The NRCS soil types were categorized into hydrologic soil groups using the guidance provided in Table 3.2.2.B in the King County Surface Water Design Manual (2009 Manual; King County 2009) (Table 1-2).

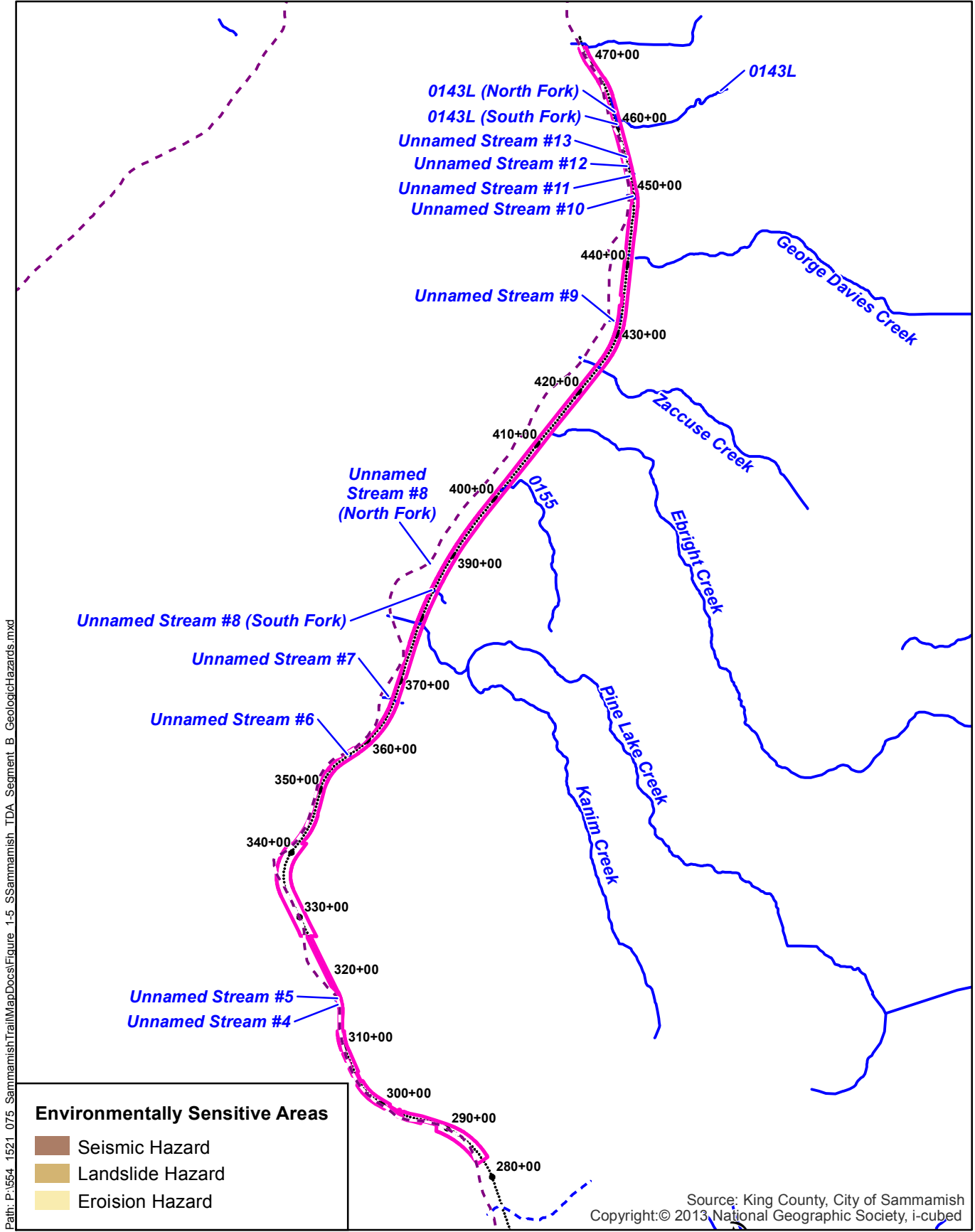
**Table 1-2. Project Area Soils**

Soil Type	Soil Name	Hydrologic Group
Ag	Alderwood gravelly sandy loam	C
Ak	Alderwood and Kitsap	C
Ev	Everett gravelly sandy loam	A/B
Kp	Kitsap silt loam	C
Ma	Mixed alluvial	A
No	Norma sandy loam	D
Rd	Ragnar-Indianola	B
Sk	Seattle muck	D









Path: P:\954\_1521\_075\_SammamishTrailMapDocs\Figure\_1-5\_Sammamish\_TDA\_Segment\_B\_GeologicHazards.mxd

**Figure 1-5  
Geologic Hazards**



## 1.4 Groundwater

The geotechnical exploration was conducted in September and October 2013. Soil borings extending at least 16.5 feet below ground surface were taken throughout the project corridor in the areas where the design identified possible need for retaining walls and infiltration facilities. Infiltration test pits were performed between Station 283+00 and Station 306+00. For most borings groundwater was not found, but when it was encountered it was at a depth of at least 9 feet below ground surface. Additionally, piezometers will be installed to monitor the groundwater levels in the areas where infiltration is proposed for full infiltration design and limited infiltration design, per the requirements of the limited infiltration flow control best management practice (FCBMP).

A Daily Field Report from Icicle Creek Engineers, Inc., will be included in a subsequent version of this report after a full season of groundwater data has been collected.

### Critical Aquifer Recharge Area

Most of the project area is located within the City of Sammamish Critical Aquifer Recharge Areas (CARA), Class 3 CARA. Class 3 CARAs are defined as being located outside wellhead protection areas that have high aquifer recharge potential. There is one group B water supply well near the trail intersection at SE 33rd Street. Additionally, there is another group B water supply well and one water supply well classified as “other” east of the trail intersection in the vicinity of Pine Lake Creek. Because there are no target areas within the project requiring water quality treatment, the CARA designation will not affect the project.

The Sammamish Municipal Code (SMC) 21A.50.280 provides development standards for projects that are located in Class 3 CARA, and that have group B water supply wells. This report addresses the SMC 21A.50.280 by explaining the project design elements for satisfying flow control requirements (Section 4.4), water quality treatment requirements (Section 4.5), and temporary erosion and sediment control (Section 8).





## 2. CONDITIONS AND REQUIREMENTS

The City of Sammamish Surface Water Design Manual Addendum directs projects disturbing over an acre to use the 2009 Manual guidelines, in conjunction with the City of Sammamish Addendum published in 2011 (City of Sammamish 2011). The project lies within the East Lake Sammamish Basin, which is designated as a Basic Flow Control area. However, a Level 2 flow control standard applies to this project as indicated in City Ordinance 02011-304, Title 13 Surface Water Management.

Based on the 2009 KCSWDM and the City of Sammamish Addendum, the project requires a full drainage review because it will result in greater than 2,000 square feet of new and replaced impervious surface. Table 2-1 provides a summary of the existing and proposed impervious surfaces within the 100-foot-wide ELST right-of-way. For the impervious surfaces presented in the project area summary (Table 2-1), the existing gravel trail was assumed to be impervious; however, for Chapter 4, flow control calculations were done assuming that the existing trail is forested, in accordance with the 2009 KCSWDM requirements.

**Table 2-1. Summary of Project Area Impervious Surfaces**

	Right-of-Way Impervious Surface (acre)	Total Right-of-Way Area (acre)	Percent Impervious Surface
Existing	5.3	44.9	12%
Proposed	8.4	44.9	19%

The 56 TDAs in the project area are the basis for the analysis of stormwater management requirements described herein. This project meets the eight core requirements and five special requirements outlined in Table 1.1.2.A in the 2009 Manual. The core and special requirements were analyzed for each TDA; this section describes, generally, how this project will meet each requirement (Table 2-2). The details of the analysis, including the basis of the hydrologic and hydraulic design, are discussed in subsequent sections.

**Table 2-2. Summary of Core and Special Requirements**

Core and Special Requirements per Table 1.1.1.A of the 2009 Manual	Proposed Stormwater Management Approach
C1 Discharge Location	Preserve existing discharge locations where possible, and provide documentation verifying no adverse impact to downstream properties where drainage will be redirected from the existing discharge locations.
C2 Offsite Analysis	Conduct offsite analysis.
C3 Flow Control	All TDAs are subject to conservation flow control area requirements.  The project design meets flow control requirements one of four ways: 1) meeting the exception from the flow control requirement for TDAs generating no more than an increase of 0.1 cubic feet per second (cfs) in the existing site conditions 100-year peak flow ( $Q_{100}$ ), 2) using Flow Control BMPs basic dispersion and limited infiltration to reduce trail runoff, 3) using infiltration facilities where feasible, and 4) direct discharge exemption.
C4 Conveyance	Runoff will sheet flow from the paved trail to the adjacent gravel shoulder and then to existing drainage pathways and ditches. The project will install new

**Table 2-2. Summary of Core and Special Requirements (continued)**

Core and Special Requirements per Table 1.1.1.A of the 2009 Manual	Proposed Stormwater Management Approach
	conveyance systems consisting of catch basins, storm drain pipes, underdrain pipes, and culverts. Conveyance systems and design calculations are described in Section 5. The project will also install 8 new box culvert for fish passage on fish bearing streams, as discussed in Section 5.
C5 Temporary Erosion and Sediment Control (TESC)	Prepare TESC plan and construction documents. The TESC plan is discussed in Section 8.
C6 Operation and Maintenance (O&M)	Prepare O&M plan. O&M is discussed in Section 10.
C7 Financial	Not applicable.
C8 Water Quality	Non-motorized trails are considered non-PGIS. Water quality treatment is not required for non-PGIS. Water quality treatment is required if a project TDA has greater than 5,000 square feet of new and replaced PGIS. None of the TDAs trigger the water quality requirement. Water quality is discussed further in Section 4.5.
S1 Other Adopted Requirements	No area-specific requirements apply to this project.
S2 Flood Hazard Area Delineation	This special requirement is not applicable to this project because the project is not in the 100-year floodplain.
S3 Flood Protection Facilities	This special requirement is not applicable to this project because the project is not in the 100-year floodplain.
S4 Source Control	This special requirement is not applicable to this project because it does not meet the commercial development permit threshold.
S5 Oil Control	This special requirement is not applicable to this project because the trail is non-PGIS and does not meet the high-use site threshold.

The City of Sammamish Surface Water Design Manual Addendum provides a list of impaired water bodies. The only water body that applies to this project is Lake Sammamish, which is a Category 5 (requiring a total maximum daily load [TMDL] plan) for dissolved oxygen and fecal coliform, and a Category 2 (water of concern) for total phosphorus. Section 1.2.2.3 Water Quality Problem Impact Mitigation of the 2009 Manual provides treatment options for projects draining to water bodies with bacteria, dissolved oxygen, and phosphorus problems. Section 3.2.1 of this report discusses how the project addresses bacteria, dissolved oxygen, and phosphorus.

## 2.1 Flow Control BMP Requirements

Section 5.2 of the KCSWDM, states that flow control best management practices (FCBMPs) seek to control runoff at or near its sources, and that implementation of the FCBMP requirement is focused primarily on individual site/lot developments as opposed to subdivisions or projects with rights-of-way. Therefore, implementation of FCBMPs are required for individual site/lot project, but are only incentive-based for subdivisions or projects with rights-of-way. This trail project is located within King County right-of-way, therefore, implementation of FCBMPs is incentive based.

KCSWDM Section 5.2.2.2 provides the following requirements for the project to receive credit for use of FCBMPs to be applied where feasible throughout any portion of the project. Table 2-3 summarizes how the project will meet the requirements to receive credit for the use of FCBMPs.

**Table 2-3. Summary of Credit Requirement for Flow Control BMP**

Requirement per Section 5.2.2.2 of the 2009 KCSWDM	Proposed FCBMP Implementation Approach
1 BMPs must serve impervious surface located only within the right-of-way.	The FCBMPs, where used, will only serve the trail impervious surface.
2 If the right-of-way is road right-of-way that will be maintained by King County, the BMPs must be approved by King County Department of Transportation through a road variance prior to engineering plan approval.	The right-of-way is owned by King County Parks, and the trail corridor is currently maintained by and will continue to be maintained by King County Parks maintenance staff. Therefore a road variance is not necessary.
3 If the right-of-way will be privately maintained, provisions must be made for future maintenance of BMPs in accordance with Core Requirement 6, Section 1.2.6 of 2009 KCSWDM.	The right-of-way is owned by King County Parks, and the trail corridor is currently maintained by and will continue to be maintained by King County Parks maintenance staff.
4 If King County will be assuming maintenance of the BMPs, the BMPs must comply with the drainage facility financial guarantee and liability requirements in Core Requirement 7, Section 1.2.7 of 2009 KCSWDM.	This is a King County Parks project, and King County Parks staff currently maintains the trail corridor and its FBMPs. King County is paying for construction of the BMPs and King County Parks maintenance staff will continue to maintain the trail corridor and the proposed FCBMPs.

The project design proposes to incorporate the following FCBMPs:

- Limited Infiltration
- Basic Dispersion

Section 4.2.1 explains how the FCBMP land use credits are applied to the target surfaces for hydrologic modeling evaluation, and Section 4.4 provides detailed descriptions of the proposed FCBMPs throughout the project.



## 3. OFFSITE ANALYSIS

### 3.1 Study Area Definition and Maps

The project lies within the Washington State Department of Ecology's (Ecology) Water Resource Inventory Area (WRIA) 8, East Lake Sammamish Basin. The 56 TDAs in the project area are defined by 18 stream segments that cross the trail and discharge into Lake Sammamish; 20 TDAs where runoff discharges directly into Lake Sammamish via manmade conveyance systems; and 18 TDAs where runoff sheet flows from the trail surface and infiltrates in the landscaping of adjacent private property. Figures 3-1 through 3-9 display the streams, culverts, flow paths, and discharge locations that define the 56 TDAs.

Many TDAs are separated by property access driveways. In these cases, the roadway runoff is not collected in the trail conveyance system (ditches along the trail), rather the runoff flows across the road crossing east to west through the project area. The roadway runoff is then collected in yard drains, trench drains, or small catch basins, and then conveyed around houses on private residences to the lake in enclosed pipe conveyance systems. The project will not contribute additional runoff to these driveway systems because the existing crossings are paved to accommodate the existing vehicle crossing. Therefore, these TDAs are exempt from Core Requirement #2 because the project will not change the rate, volume, duration, or location of discharges to and from the project site.

### 3.2 Resource Review

Parametrix reviewed various resources to identify the sensitive areas within the project area. Resources include the King County iMAP: Interactive Mapping Tool, which allows usage of the County's geographic information system (GIS) data, and the City of Sammamish maps that are provided on the City's website, and via GIS data transfer from the City GIS manager. Sensitive areas within the project area include wetlands, streams, landslide hazard areas, and Lake Sammamish, with its associated flood hazards downslope of the project.

As discussed in Section 1.3, review of the City of Sammamish Environmentally Sensitive Areas Geologic Hazards map indicates that the project is surrounded by erosion and landslide hazard areas. However, these areas are not located within the project right-of-way, as depicted in Figure 1-5. Additionally, the Draft Geotechnical Report has identified the project area subsurface conditions.

#### 100-Year Floodplain

Review of the City of Sammamish Environmentally Sensitive Areas Map indicates that project right-of-way is within the 100-year floodplain of Lake Sammamish. Using the Federal Emergency Management Agency (FEMA) Flood Insurance Rate Map (FIRM) 530330685F, effective May 16, 1995, the 100-year floodplain elevation for Lake Sammamish is 33.00 feet (NGVD 29). The vertical datum for the project is NAVD 88. To convert from NVGD 29 to NAVD 88 the datum shift adds 3.57 feet to get 36.57 feet (NAVD 88). Trail improvements occur at elevations above 45 feet (NAVD 88). Therefore, although the 100-year floodplain boundary line is depicted within the project right-of-way, the proposed project improvements will not impact the 100-year floodplain elevation. The 100-year floodplain boundary is depicted on Figures 3-1 through 3-9. Trail elevations are located on the plan sheets located in Appendix A. The City of Sammamish Environmentally Sensitive Areas Map does not include the 100-year floodplain for streams, Pine Lake Creek, 0155, Ebright Creek, Zaccuse Creek, George Davis Creek, 0143L, or Unnamed Streams 4 through 11.

### 3.2.2 Water Quality Problems Requiring Special Attention

The City of Sammamish Surface Water Design Manual Addendum provides a list of impaired water bodies, based on the Department of Ecology 2008 Water Quality Assessment, approved by the US. Environmental Protection Agency on January 29, 2009. The only water body that applies to this project is Lake Sammamish, which is a Category 5 (requiring a total maximum daily load [TMDL] plan) for dissolved oxygen and fecal coliform, and a Category 2 (water of concern) for total phosphorus. Section 1.2.2.3 Water Quality Problem Impact Mitigation of the 2009 KCSWDM provides treatment options for projects draining to water bodies with bacteria, dissolved oxygen, and phosphorus problems. The remainder of this section discusses how these problems relate to the South Sammamish Segment B project.

#### Bacteria Problem

None of the TDAs have enough new and replaced pollution-generating impervious surfaces (PGIS) to trigger the requirement of a water quality treatment facility. If a water quality facility is required as stated in Core Requirement #8, then a sand filter, stormwater wetland, or an emerging technology treatment method that removes fecal coliform is needed. Because no water quality facilities are required, the above facilities are not applicable. However, pet stations will be provided along the trail to encourage owners to pick up after their pets.

#### Dissolved Oxygen Problem

None of the mitigation requirements are applicable for this water quality problem. This project does not include a wet pond or wet vault; therefore, the aeration techniques do not apply.

If the dissolved oxygen (DO) problem is documented to be caused by excessive nutrients, and a water quality facility is required, then a treatment facility option from the Sensitive Lake Protection Menu shall be included in the treatment system. However, this requirement is not applicable because no water quality facilities are required.

#### Phosphorus Problem

No water quality facilities are required for this project; therefore, the mitigation requirements for the phosphorus problem do not apply. Fertilizers will not be used in Wetland mitigation planting areas, and if fertilizers are necessary for other landscaped areas, care will be taken to use non-phosphorus based fertilizers.

For the purposes of applying Erosion and Sediment Control Standards, the project is assumed to be located within a designated Sensitive Lake Water Quality Treatment Area.

### 3.3 Field Inspection

Parametrix performed a Level 1 field inspection of the trail corridor on April 16 and 24, 2013. The weather was sunny with brief showers in the afternoon on the 16<sup>th</sup> and sunny on the 24<sup>th</sup>. The purposes of the field inspection was to identify any drainage patterns, verify TDA boundaries, and identify drainage problems and erosion problems downstream of the ELST corridor. A description of each outfall subject to the downstream analysis requirement is provided in Appendix B. Several of the TDAs will not increase runoff to the outfall and are therefore exempt from the downstream analysis requirement. Descriptions of the upstream flow paths are also included in Appendix B, at least to the point where the project could backwater. It is unlikely that any of the water courses would backwater across the ELSP due to the steep slopes crossing the project.



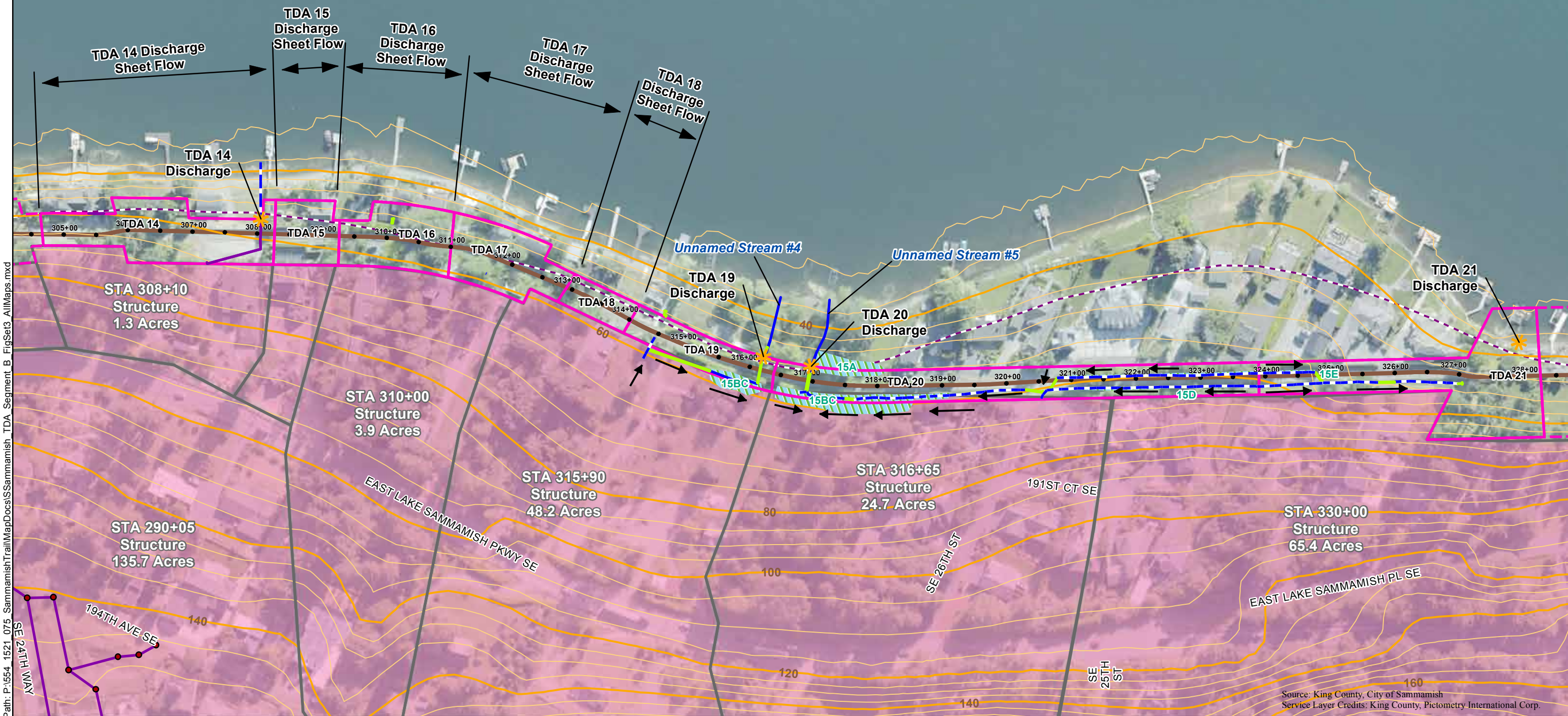
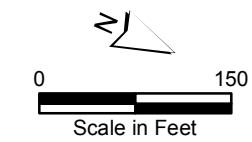






Path: P:\654\_1521\_075\_SammamishTrailMapDocs\Sammamish\_TDA\_Segment\_B\_FigSet3\_AltMaps.mxd

Parametrix



- 480+00 485+00 Proposed Stationing
- 480+00 Proposed Trail
- Contributing TDA Boundary
- Adjacent TDA Boundary
- TDA Discharge Location
- Stream
- Culvert
- Storm Ditch
- Storm Pipe
- SDMH/CB
- Contour - 20 ft
- Contour - 5 ft
- 100-year Floodplain Boundary
- Offsite Drainage Area
- Wetland
- Flow Path

Source: King County, City of Sammamish  
Service Layer Credits: King County, Pictometry International Corp.

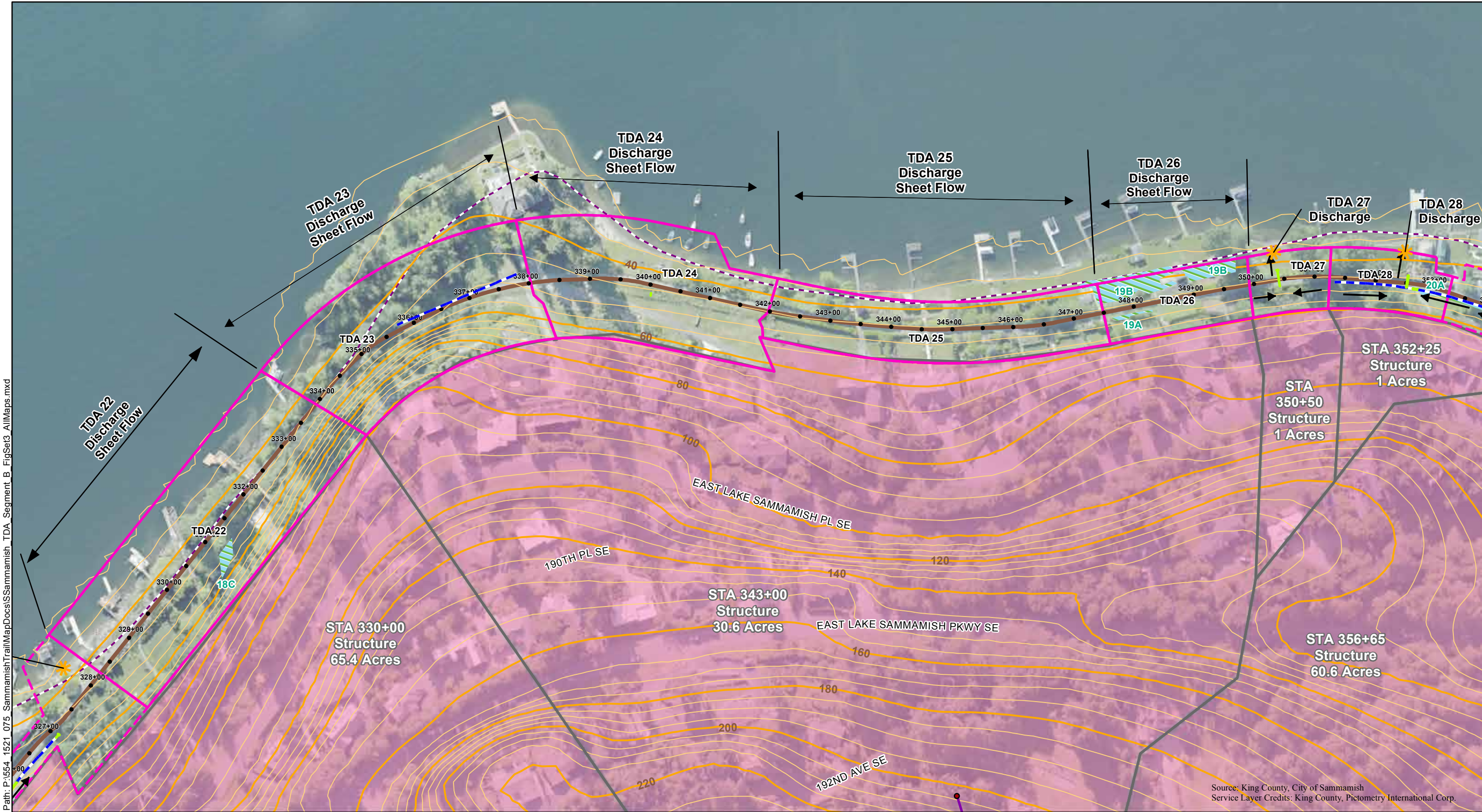
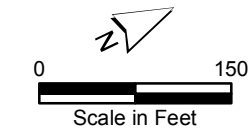
**Figure 3-2**  
**Threshold Discharge Areas 14 - 21**





Path: P:\654\_1521\_075\_SammamishTrailMapDocs\Sammamish\_TDA\_Segment\_B\_FigSet3\_AltMaps.mxd

Parametrix



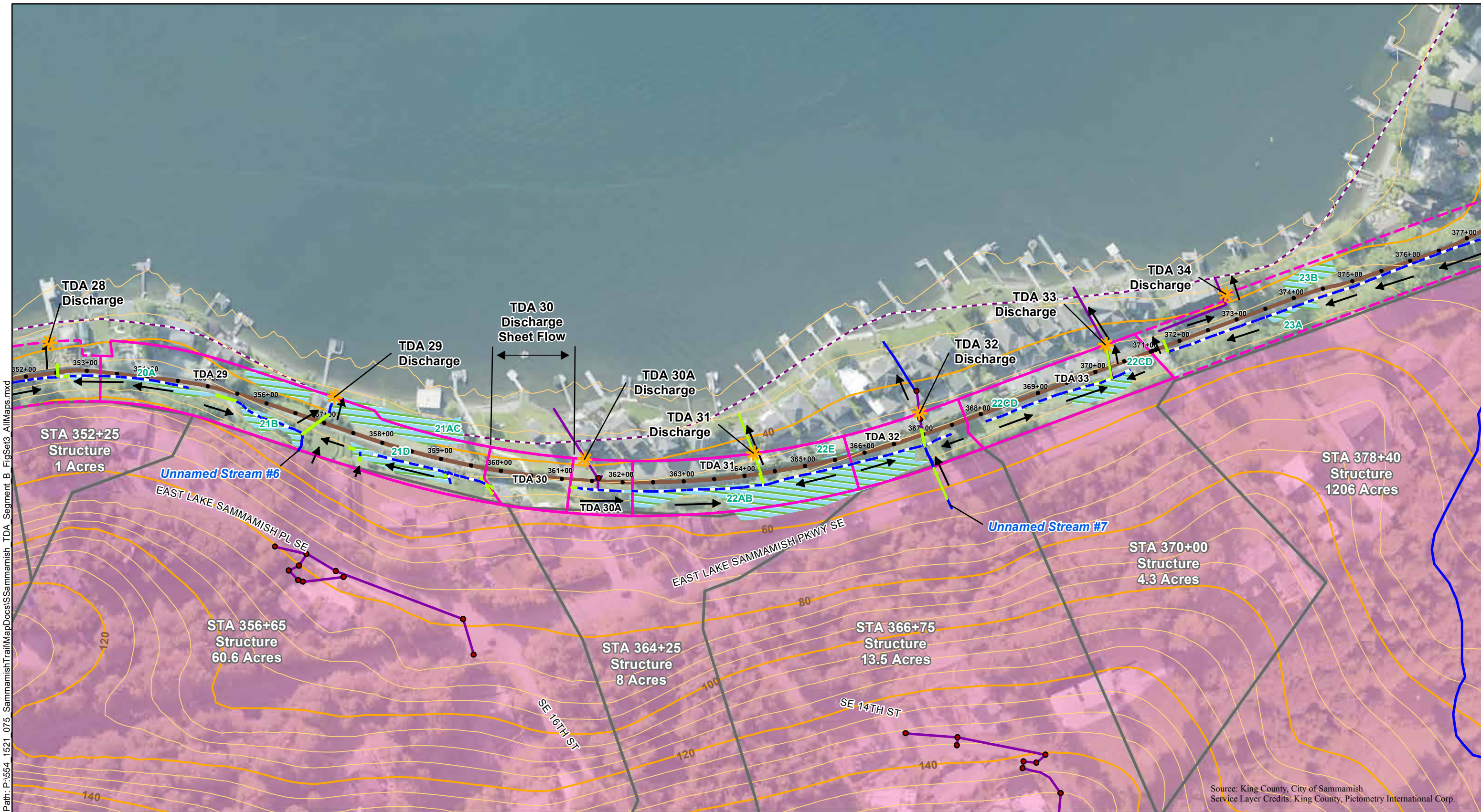
Source: King County, City of Sammamish  
Service Layer Credits: King County, Pictometry International Corp.

- Proposed Stationing
  - Proposed Trail
- Contributing TDA Boundary
  - Adjacent TDA Boundary
  - TDA Discharge Location
- Stream
  - Culvert
  - Storm Ditch
  - Storm Pipe
- SDMH/CB
  - Contour - 20 ft
  - Contour - 5 ft
- 100-year Floodplain Boundary
  - Offsite Drainage Area
  - Wetland
  - Flow Path

**Figure 3-3**  
**Threshold Discharge Areas 22 - 28**



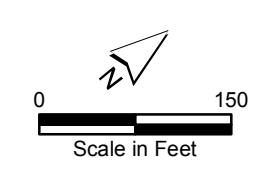




Path: P:\654\_1521\_075\_SammamishTrailMapDocs\Sammamish\_TDA\_Segment\_B\_FigSet3\_AltMaps.mxd

Source: King County, City of Sammamish  
Service Layer Credits: King County, Pictometry International Corp.

Parametrix



- |                     |                           |             |                 |                              |
|---------------------|---------------------------|-------------|-----------------|------------------------------|
| Proposed Stationing | Contributing TDA Boundary | Stream      | SDMH/CB         | 100-year Floodplain Boundary |
| Proposed Trail      | Adjacent TDA Boundary     | Culvert     | Contour - 20 ft | Offsite Drainage Area        |
|                     | TDA Discharge Location    | Storm Ditch | Contour - 5 ft  | Wetland                      |
|                     |                           | Storm Pipe  |                 | Flow Path                    |

**Figure 3-4**  
**Threshold Discharge Areas 29 - 33**



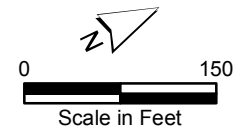




Path: P:\654\_1521\_075\_SammamishTrailMapDocs\Sammamish\_TDA\_Segment\_B\_FigSet3\_AIMaps.mxd

Parametrix

Source: King County, City of Sammamish  
 Service Layer Credits: King County, Pictometry International Corp.



- |                     |                           |             |                 |                              |
|---------------------|---------------------------|-------------|-----------------|------------------------------|
| Proposed Stationing | Contributing TDA Boundary | Stream      | SDMH/CB         | 100-year Floodplain Boundary |
| Proposed Trail      | Adjacent TDA Boundary     | Culvert     | Contour - 20 ft | Offsite Drainage Area        |
|                     | TDA Discharge Location    | Storm Ditch | Contour - 5 ft  | Wetland                      |
|                     |                           | Storm Pipe  |                 | Flow Path                    |

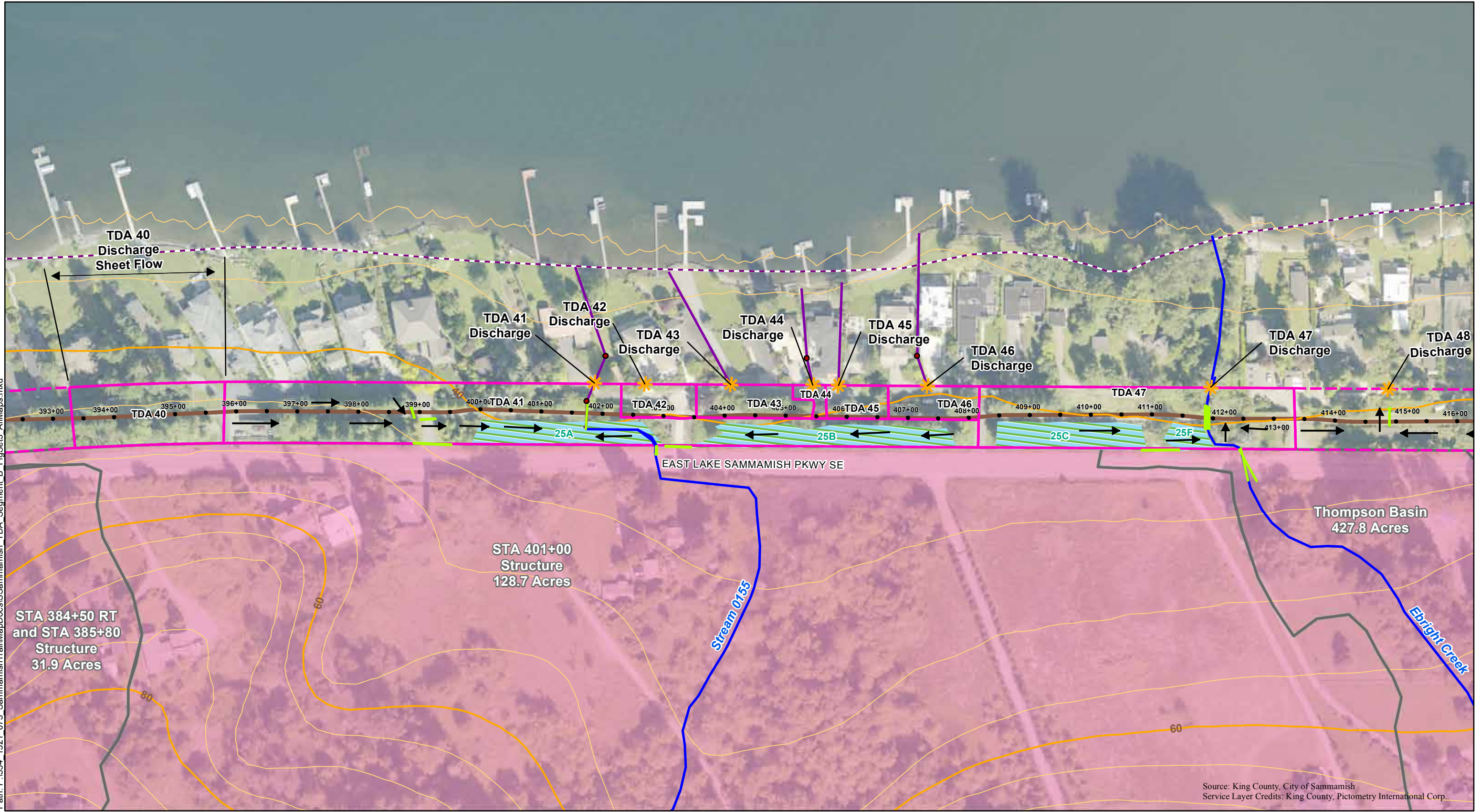
**Figure 3-5**  
**Threshold Discharge Areas 34 - 39**





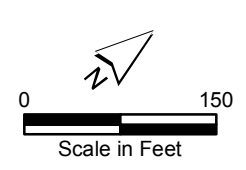


Path: P:\654\_1521\_075\_SammamishTrailMapDocs\Sammamish\_TDA\_Segment\_B\_FigSet3\_AIMaps.mxd



Source: King County, City of Sammamish  
 Service Layer Credits: King County, Pictometry International Corp.

Parametrix



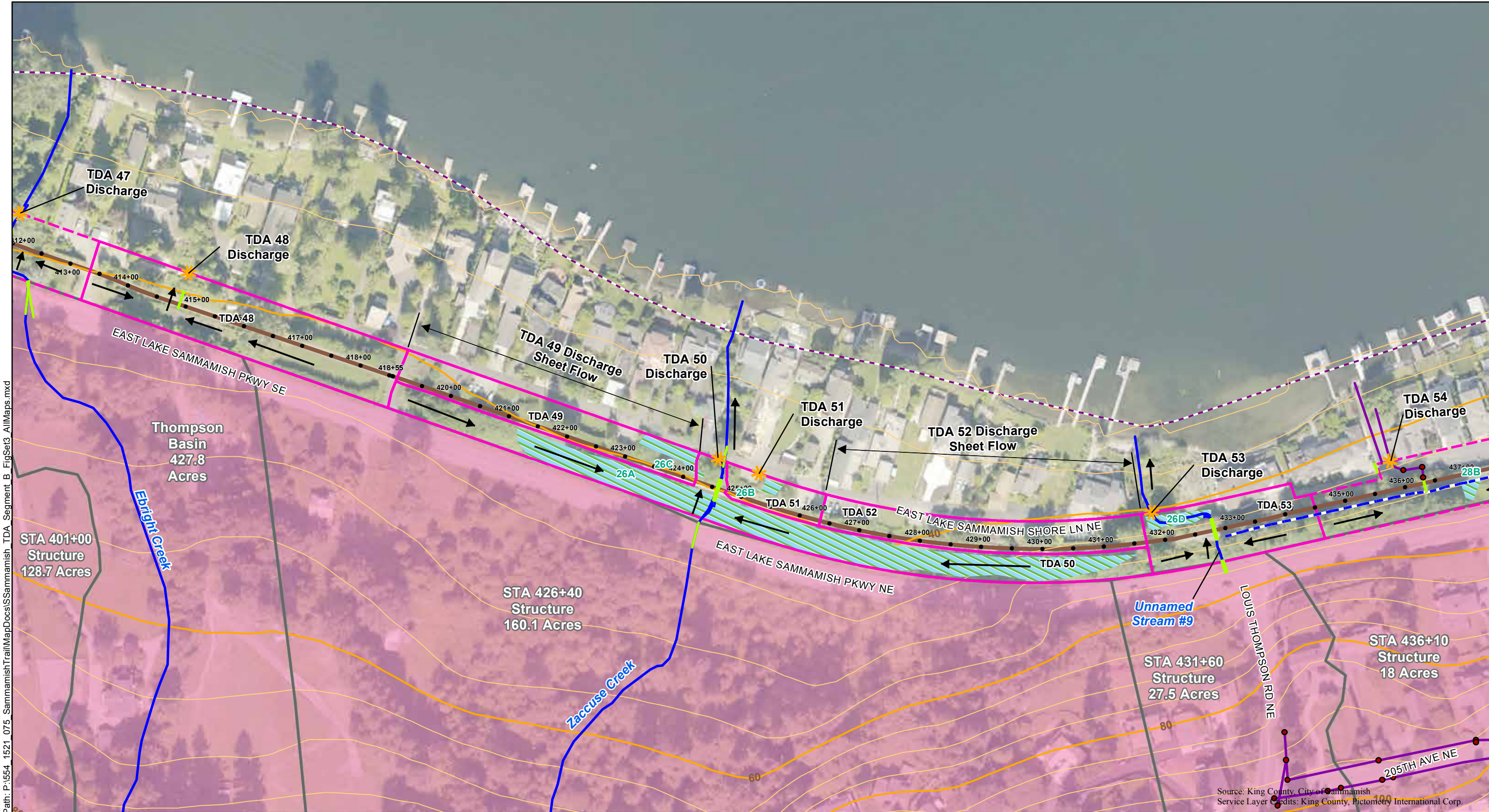
- Proposed Stationing
- Proposed Trail
- Contributing TDA Boundary
- Adjacent TDA Boundary
- TDA Discharge Location
- Stream
- Culvert
- Storm Ditch
- Storm Pipe
- SDMH/CB
- Contour - 20 ft
- Contour - 5 ft
- 100-year Floodplain Boundary
- Offsite Drainage Area
- Wetland
- Flow Path

**Figure 3-6**  
**Threshold Discharge**  
**Areas 40 - 47**

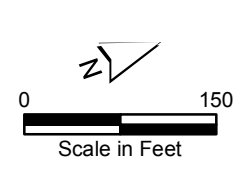




Path: P:\654\_1521\_075\_SammamishTrailMapDocs\Sammamish\_TDA\_Segment\_B\_FigSet3\_AIMaps.mxd



Parametrix



- Proposed Stationing
- Proposed Trail
- Contributing TDA Boundary
- Adjacent TDA Boundary
- TDA Discharge Location
- Stream
- Culvert
- Storm Ditch
- Storm Pipe
- SDMH/CB
- Contour - 20 ft
- Contour - 5 ft
- 100-year Floodplain Boundary
- Offsite Drainage Area
- Wetland
- Flow Path

**Figure 3-7**  
**Threshold Discharge Areas 48 - 53**

Source: King County, City of Sammamish  
Service Layer Credits: King County, Pictometry International Corp.



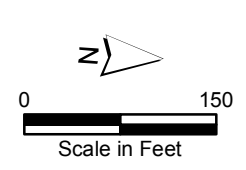


Path: P:\654\_1521\_075\_SammamishTrailMapDocs\Sammamish\_TDA\_Segment\_B\_FigSet3\_AIMaps.mxd



Source: King County, City of Sammamish  
Service Layer Credits: King County, Pictometry International Corp.

Parametrix



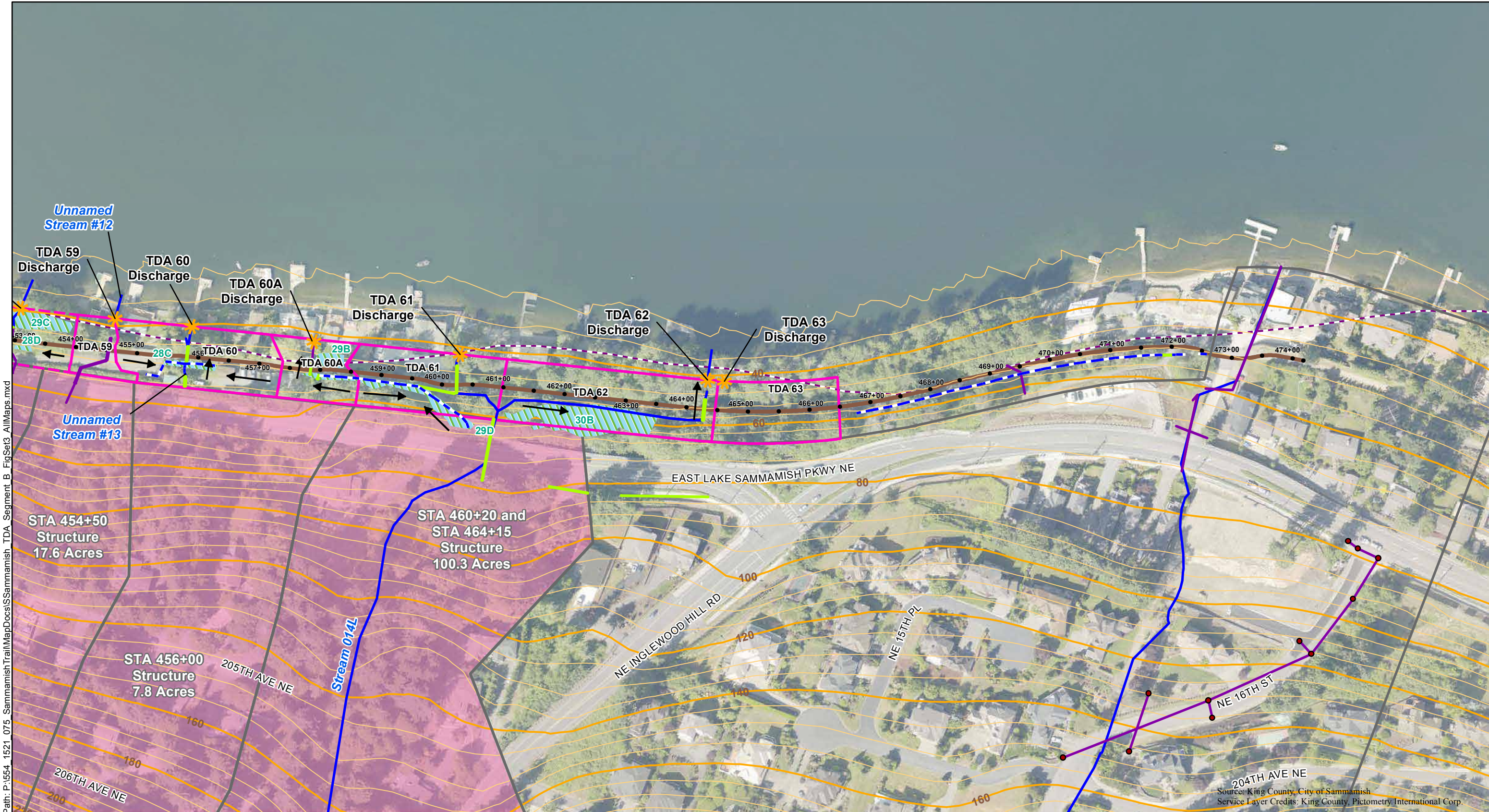
- 430+00 435+00 Proposed Stationing
- 480+00 485+00 Proposed Stationing
- Proposed Trail
- Contributing TDA Boundary
- Adjacent TDA Boundary
- TDA Discharge Location
- Stream
- Culvert
- Storm Ditch
- Storm Pipe
- SDMH/CB
- Contour - 20 ft
- Contour - 5 ft
- 100-year Floodplain Boundary
- Offsite Drainage Area
- Wetland
- Flow Path

**Figure 3-8**  
**Threshold Discharge Areas 54 - 58**

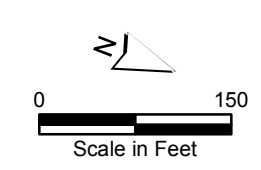




Path: P:\654\_1521\_075\_SammamishTrailMapDocs\Sammamish\_TDA\_Segment\_B\_FigSet3\_AltMaps.mxd



Parametrix



- Proposed Stationing
- Proposed Trail
- Contributing TDA Boundary
- Adjacent TDA Boundary
- TDA Discharge Location
- Stream
- Culvert
- Storm Ditch
- Storm Pipe
- SDMH/CB
- Contour - 20 ft
- Contour - 5 ft
- 100-year Floodplain Boundary
- Offsite Drainage Area
- Wetland
- Flow Path

Source: King County, City of Sammamish  
Service Layer Credits: King County, Pictometry International Corp.

**Figure 3-9**  
**Threshold Discharge**  
**Areas 59 - 63**







During the field inspection, it was observed that the trail runoff had three general flow patterns: 1) runoff east to a ditch that conveys runoff to a culvert that discharges west beneath the trail, 2) sheet-flow west into vegetation between the trail and Lake Sammamish, and 3) sheet-flow west into adjacent private property vegetation and landscaping.

In addition to the trail runoff patterns, the driveway intersections had typical drainage patterns. Driveway runoff was observed to be managed by two types of private drainage systems on the properties between the trail and Lake Sammamish: 1) offsite driveway runoff is diverted and collected prior to mingling with trail runoff, then the driveway runoff sheet flows across the trail west toward a house and is collected in either a trench drain or catch basin prior to reaching the house, or 2) offsite flows are not diverted but flow across the trail into a trench drain or catch basin collection system located in the property access road or driveway.

Because of right-of-entry limitations, Parametrix was not allowed to follow the drainage patterns around the houses to the lake in most cases. However, for areas that have documentation of drainage complaints or drainage issues, property owners met King County to discuss the drainage concerns and explain what the drainage systems are doing in those locations. Drainage complaints are discussed further in Section 3.4.

### 3.4 Drainage System and Problem Descriptions

Parametrix contacted King County Parks and the City of Sammamish to inquire if there were records of complaints regarding drainage problems along the trail corridor. The City of Sammamish provided a record of drainage complaints, and these are provided in Appendix B. From the descriptions of the City's drainage complaints log, all of the drainage problems were resolved. Therefore, drainage problems described in this section may not necessarily reflect those complaints. Additionally, property owners have cooperated with King County Parks to provide explanations of drainage problem areas that continue to be a problem. The local drainage and flooding problems identified along the trail corridor are discussed in this section according to TDA, trail station and property. Photo reports of the drainage problem areas are also provided in Appendix B.

#### TDA 17 – Station 311+00 to 312+90

##### *2805 and 2807 East Lake Sammamish Parkway SE – Conveyance Nuisance Problem*

The property owners of 2805 and 2807 East Lake Sammamish Parkway SE sent the project team notices of drainage issues in March 2014 and followed up with a second problem description and sketch of the existing drainage on their property in March 2016.

From the property owners' descriptions, surface water runoff from East Lake Sammamish Parkway flows onto their property and enters a private drainage system consisting of French drain and catch basins for collection and 4" corrugated drain pipe for conveyance down the steep slope east of the trail, beneath the trail, and west to Lake Sammamish. This private drain system works, but based on the description of the complaints, it gets overwhelmed during large storm events, and overflows. During the large storm events, the embankment east of the trail gets saturated and surface runoff sheet flows down the private concrete steps, across the trail, and onto the private property on west side of the trail. If the system has any blockages, then backup and ponding occurs.

Documentation of the property owner correspondences for this area provided in Appendix B.

## TDA 18 – Station 312+90 to 314+00

### *2721 East Lake Sammamish Parkway SE – Conveyance Nuisance Problem*

The property owner has complained of puddles forming on the trail when it rains, and a “sheet of water” going onto the house. During site investigations there were no indications of erosion problems due to high velocity sheet flow, nor were there indications of a surface water source (onsite or offsite upstream) that would be generate enough runoff to cause a sheet of water to go to the property owners home.

## TDA 30A – Station 361+15 to 362+16

### *1433 and 1439 East Lake Sammamish Shore Lane SE – Conveyance Nuisance Problem*

The property owner at 1439 East Lake Sammamish Shore Lane SE has made complaints regarding runoff from East Lake Sammamish Shore Lane SE and trail runoff overflowing catch basins located in East Lake Sammamish Shore Lane SE and flowing toward the home during large storm events.

The existing drainage system consists of a 6-inch diameter pipe that crosses the trail near Sta. 361+60 and connects to a small area drain structure west of the trail. This system continues west via 6-inch pipe to a catch basin located in East Lake Sammamish Shore Lane SE near Sta. 361+35, and further west in a 4-inch diameter drain pipe on private property prior to discharging to Lake Sammamish. The reduction in pipe size indicates that the private conveyance systems is undersized, and in addition to clogged pipes, were the cause of the drainage system overflow that caused the complaint.

Surface runoff that does not get conveyed by the storm drain flows southwest over the paved driveway toward the home at 1433 East Lake Sammamish Shore Lane SE.

The project team and King County Maintenance crews performed a site investigations of the existing trail drainage system in this are on January 29, 2016 and March 9, 2016, respectively. The existing conveyance pipes and catch basins located east and immediately west of the trail were clogged in this area. The maintenance crew cleaned them out on March 9, 2016.

Two photo logs of this area are provided in Appendix B.

## TDA 31 – Station 362+16 to 365+75

### *1411 East Lake Sammamish Parkway SE – Conveyance Nuisance Problem*

There are no documented drainage complaints regarding this area, but neighbors have expressed concern that runoff from East Lake Sammamish Shore Lane SE sometimes creates a nuisance. The project design does not propose to modify this access road, therefore, runoff problems related to roadway drainage collection are not considered as part of the project design.

No mitigation evaluation necessary.

## TDA 32 – Station 365+75 to 367+75

### *1309 East Lake Sammamish Shore Lane SE – Conveyance Nuisance Problem*

Reports of channel flooding were reported by home owner Christensen (1309 East Lake Sammamish Shore Lane SE) in March 2003. The complaints stated that the problem was due to the large culvert beneath the parkway allowing large volumes of water to the downstream properties. The City Staff commented that the problem was due to a partially plugged trail culvert that was jetted out as response to the complaint. Maintenance staff now keeps the culvert from been plugged, and there have been no complaints since.

No mitigation evaluation necessary.

## TDA 43 – Station 403+50 to 405+40

### *215 East Lake Sammamish Parkway SE – Conveyance Nuisance Problem*

Reports of ponding on East Lake Sammamish Shore Lane SE were reported by home owner Dhinsa (215 East Lake Sammamish Parkway SE) due to the poor condition of the gravel road used for private property access. After field investigation, it was determined that the ponding does not create property access problems, nor does it cause damage to buildings on the downstream private properties. This complaint is not related to the trail project improvements and, therefore, the project does not propose to make any improvements to this area.

No mitigation evaluation necessary.

## TDA 54 – Station 434+50 to 441+10

### *439 East Lake Sammamish Shore Lane NE – Conveyance Nuisance Problem*

After a rain event in April 2013, the property owner at 439 East Lake Sammamish Shore Lane NE reported a drainage complaint that the boat launch driveway area along the south side of the property was saturated and the pavers were floating due to the flooding. The County performed a site investigation at this time and notified the property owner the problem was due to a clogged pipe in the boat launch driveway on their property. After a rain event in December 2015, the new property owner at 439 East Lake Sammamish Shore Lane NE reported the same condition of a saturated boat launch driveway and floating pavers. The design team performed a site visit on December 7, 2015, and documented the flow path of offsite contributing runoff, trail runoff and runoff from East Lake Sammamish Shore Lane NE.

Downstream of the 12-inch trail culvert, runoff is collected in a catch basin. From this catch basin runoff is conveyed through 6-inch drain pipe to a series of catch basins and the conveyance ends at a small square area drain located at the end of the boat launch driveway. There is no discharge pipe from this area drain.

East Lake Sammamish Shore Lane NE runoff is collected in a separate catch basin located just south of the 6-inch storm drain pipes at the east end of the boat launch driveway. Collected runoff is conveyed west beneath the property at 425 East Lake Sammamish Shore Lane NE, and discharges to Lake Sammamish, via 12-inch ADS pipe.

On February 16, 2016, the pipe system was inspected with a pipe camera. This effort identified that the pipe material for the system is PVC, and that a segment of 6-inch PVC pipe was crushed near the west edge of East Lake Sammamish Shore Lane NE where it transitions to the property owner's boat launch.

Two photo logs of this area are provided in Appendix B.

## TDA 56 – Station 444+30 to 448+66

### *813 and 833 East Lake Sammamish Parkway NE – Conveyance Nuisance Problem*

It was observed during the field inspection that a culvert end located at the north end of Wetland 28E (across from 833 East Lake Sammamish Parkway NE) conveyed runoff northward, but the downstream culvert end could not be found. Additionally, the property owners adjacent to Wetland 28E, complained that the ponding water in the ditch on the east side of the trail was due to the culvert not draining properly. King County Parks maintenance unclogged the pipe in May 2016, and was able to determine that the culvert flows north from near Station 446+60 to approximately Station 448+40, where the pipe makes a 90 degree turn west, and discharges through a wood garden wall to planter bed located within the trail property boundary, but in an area that looks more like the yard of the home located at 833 East

Lake Sammamish Parkway NE. There is no distinct flowpath from this pipe outfall to Lake Sammamish. It appears that runoff would saturate the garden, before flowing onto and saturating the lawn. From the lawn, runoff would flow toward the house at 833 East Lake Sammamish Parkway NE before reaching Lake Sammamish.

#### TDA 60A – Station 456+25 to 458+65

##### *1111 and 1119 East Lake Sammamish Parkway NE – Conveyance Nuisance Problem*

The design team conducted a site visit on May 18<sup>th</sup>, 2016, at the trail near property 1119 East Lake Sammamish Parkway NE following a complaint from the adjacent homeowner, Mr. Hill, regarding the ponded water in the ditch across from his property. Although the property owner described the area of ponding water a ditch, this area is regulated as a wetland, and for the project is named Wetland 29D. There is a low point in wetland channel, which contains a minor slope that creates slow moving and ponded water for most of the year. A photo log was prepared to document the drainage in the vicinity of the complaint on July 13, 2016.

Stormwater enter the project area in a pipe that crosses under ELSP. The pipe travels beneath the gravel parking area east of the trail near Station 457+50. The pipe discharges toward the trail beneath a wall made of old concrete slabs stacked on each other (concrete rubble wall) that holds up the parking area.

Based on this site investigation, the problem is due to a 24 inch CMP pipe located at the south end of Wetland 29D that is clogged. The wetland has a high point near station 458+65, and the portion of the wetland flows south to the culvert ponds due to the clogged pipe. This pipe is directed south beneath

An additional site visit was conducted on August 24, 2016 to speak with property owner, Mr. Wolfe (1111 East Lake Sammamish Parkway NE), to obtain knowledge of the drainage in this area. Mr. Wolfe described the existing drainage system starting at the pipe behind the concrete rubble wall. He said that an 8-inch pipe is buried beneath the east trail ditch (near Station 457+50). This pipe conveys the parkway pipe south to approximately Station 456+30, where the pipe turns 90 degrees west. The pipe continues west beneath the trail and along the south property line of the home at 1111 East Lake Sammamish Parkway NE. The pipe discharges through a concrete bulkhead that serves as a partial foundation and water feature for the home. Mr. Wolfe expressed that he would like to ensure that the stormwater that flows in to this water feature continues to do so, and is not diverted elsewhere.

## 3.5 Mitigation of Existing or Potential Problems

This section provides proposed mitigation measures to address the drainage problems identified above.

#### TDA 17 – Station 311+00 to 312+90

##### *2805 and 2807 East Lake Sammamish Parkway SE – Conveyance Nuisance Problem*

This TDA is exempt from flow control facility requirements because proposed improvements will generate less than 0.1 cfs in the 100-year peak flow from the historic (forested) pre-developed site condition to the proposed (impervious) design condition. This drainage problem does not impact the trail, therefore, the design does not propose to improve this private drainage system. This drainage problem originates on private property east of the trail and exists because the private drainage system overflows.

## TDA 18 – Station 312+90 to 314+00

### *2721 East Lake Sammamish Parkway SE – Conveyance Nuisance Problem*

This TDA is exempt from flow control facility requirements because proposed improvements will generate less than 0.1 cfs in the 100-year peak flow from the historic (forested) pre-developed site condition to the proposed (impervious) design condition. Therefore, no drainage system improvements are proposed. The proposed paved trail will have a constant cross slope which will reduce the likelihood of ponding water on the trail.

## TDA 30A – Station 361+15 to 362+16

### *1433 and 1439 East Lake Sammamish Shore Lane SE – Conveyance Nuisance Problem*

This TDA is exempt from flow control facility requirements because proposed improvements will generate less than 0.1 cfs in the 100-year peak flow from the historic (forested) pre-developed site condition to the proposed (impervious) design condition. The project design proposes to improve the existing conveyance system for trail and roadway runoff, and reduce the possibility of the system getting clogged. The proposed system will connect to the last catch basin located in East Lake Sammamish Shore Lane SE near Sta. 361+35 before the storm system continues onto private property. No improvements will be made to the system outside of the property boundary.

Conveyance calculations were performed using the Rational Method, as described in Section 5.5, to confirm that the 12-inch storm drain has capacity to convey contributing flows during the 25-year storm event.

## TDA 54 – Station 434+50 to 441+10

### *439 East Lake Sammamish Shore Lane NE – Conveyance Nuisance Problem*

In TDA 54, project improvements do not meet the flow control facility exception requirements. The design proposes to improve the conveyance system to provide a direct discharge outfall to Lake Sammamish, and will thus satisfy the direct discharge flow control exemption. The proposed solution is to remove the existing area drains and 6-inch drain pipes, with type 1 catch basins and 12-inch storm drain that will directly discharge to Lake Sammamish at the end of the boat launch driveway located on 439 East Lake Sammamish Shore Lane NE.

The drainage problem exists because the 12-inch trail culvert is connected to 6-inch drain system in East Lake Sammamish Shore Lane NE that has a segment of crushed pipe and that does not have an end that discharges to Lake Sammamish. The simple solution would be to modify the drainage system to connect to the existing catch basin located in East Lake Sammamish Shore Lane NE that discharges to the lake via 12-inch ADS storm pipe. This option was explored, however, the property owner at 425 East Lake Sammamish Shore Lane NE did not want to have any additional pipes connected to their catch basin and outfall pipe.

Conveyance calculations are described in Section 5.5.

## TDA 56 – Station 444+30 to 448+66

### *813 and 833 East Lake Sammamish Parkway NE – Conveyance Nuisance Problem*

This TDA is exempt from flow control facility requirements because proposed improvements will generate less than 0.1 cfs in the 100-year peak flow from the historic (forested) pre-developed site condition to the proposed (impervious) design condition. Therefore, the project is not required to provide detention or retention improvements. However, after un-clogging the 12-inch culvert end located at the north end of Wetland 28E, the downstream property owner at 833 East Lake Sammamish

Parkway NE has reportedly noticed more runoff entering his planting bed and yard during rain events. This area is located within the project right-of-way.

The design proposes to improve the conveyance system along the trail from Wetland 28E north and west to the private property. However, there is no existing conveyance to connect to west of the trail that would convey runoff to Lake Sammamish. Therefore, the project design proposes to continue the 12-inch storm drain to include a new direct discharge to Lake Sammamish. The proposed design will require a storm drain pipe to be buried on the north side of the home at 833 East Lake Sammamish Parkway NE. The proposed design will also require a drainage covenant or easement with the property owner at 833 East Lake Sammamish Parkway NE, and possible with the property owner at 835 East Lake Sammamish Parkway NE, depending on additional survey of the proposed pipe alignment at the property boundary and construction access requirements.

Conveyance calculations are described in Section 5.5.

#### TDA 60A – Station 456+30 to 458+65

##### *1111 and 1119 East Lake Sammamish Parkway NE – Conveyance Nuisance Problem*

This TDA is exempt from flow control facility requirements because proposed improvements will generate less than 0.1 cfs in the 100-year peak flow from the historic (forested) pre-developed site condition to the proposed (impervious) design condition. Therefore, the project is not required to provide detention or retention improvements.

The proposed design will improve the conveyance system through the project area by removing the existing buried drainage system and installing 12-inch storm drain pipe and type 1 and type 2 catch basins. The improvements start at the catch basin located at the east end of the gravel parking area near station 457+25, cross the trail near Station 456+30, where the existing 8-inch drain pipe is said to be located, and connect to the existing drain pipe in a new type 2 catch basin located west of the trail near Station 456+30. Potholing of the storm utilities and survey will be performed to be sure the proposed system ties into the existing system. Additionally, underdrains will be installed in the east trail shoulder to convey trail runoff south to the proposed conveyance system that will connect to the existing drain pipe the flows to Mr. Wolfe's property (1111 East Lake Sammamish Parkway NE discharges).

Conveyance calculations are described in Section 5.5.

## 4. FLOW CONTROL AND WATER QUALITY FACILITY ANALYSIS AND DESIGN

### 4.1 Existing Site Hydrology

The ELST is currently a 10-foot-wide gravel path that uses existing ditches and cross culverts that primarily remain from former railroad construction. The railroad ballast serves as a foundation for the trail. The adjacent areas (outside the ballast prism) consist of forest, wetlands, landscaping, and other impervious surfaces such as driveways and parking areas.

#### 4.1.1 Existing (Pre-developed) Land Use

The definition of new impervious surface includes existing gravel surfaces that are upgraded to pavement (King County 2009). Target surfaces do not include existing impervious surfaces that are not disturbed by project activities.

For the purposes of this analysis, it was assumed that target surfaces requiring mitigation within Conservation Flow Control areas include the following:

- Areas within the new trail limits
- Retaining walls (concrete blocks)
- Rest Stops
- Existing paved driveways that will be replaced as part of this project

The project used the hydrologic model Western Washington Hydrology Model version 4 (WWHM4) to determine flow control requirements. WWHM4 is an approved hydrologic model in accordance with Chapter 3 of the City Amendment. To comply with flow control requirements, pre-developed land uses within target surface areas were assumed to have a historical (forested) land use. Pre-developed land uses outside the target surfaces were not modeled. The native soils underlying the trail corridor are a mix of outwash and till soils. In some cases, the soil was modeled as till even though the NRCS map indicate outwash. This was because the project geotechnical report indicated that the soils are till or have a high water table making infiltration infeasible.

Table 4-1 summarizes the pre-developed and developed land use for each TDA. A detailed breakdown of the project area land use for each TDA is provided in Appendix C1.

### 4.2 Developed Site Hydrology

#### 4.2.1 Developed Land Use

The proposed project will upgrade the existing 10-foot-wide gravel trail to a 12-foot-wide paved trail with 2- to 3-foot-wide gravel shoulders. Walls are proposed in areas where the trail is bordered by a wetland on one or both sides, and where steep slopes require cut or fill walls. The paved trail and the gravel shoulders are new impervious surfaces. Non-target surfaces in the proposed conditions do not change from existing conditions, and were not modeled.

As discussed in Section 2.1, the project proposes FCBMPs – limited infiltration and basic dispersion – to promote infiltration and reduce the trail runoff throughout the project. FCBMPs (basic Section 1.2.3.1.B

of the 2009 KCSWDM states land use credits may be applied to the target surfaces served by FCBMPs, and Table 1.2.3.C in Section 1.2.3.2.D of the 2009 KCSWDM provides guidance for applying land use credits when sizing flow control facilities and assessing exceptions from the flow control facility requirement.

According to Table 1.2.3.C of the 2009 KCSWDM, the land use credits are applied for facility sizing as follows:

**Limited Infiltration** – for impervious surfaces tributary to limited infiltration facility, the impervious area modeled as 50-percent impervious and 50-percent grass

**Basic Dispersion** – for impervious surfaces that are dispersed, the impervious area modeled as 50-percent impervious and 50-percent grass

These land use credits for facility sizing are reflected in the Table 4-1 Land Use Summary, for the following TDAs in which the FCBMPs are applied:

**Limited Infiltration**

- TDA 29 – B-Line Station 355+40 to Station 359+75
- TDA 34 – C-Line Station 371+71 to Station 378+80
- TDA 41 – C-Line Station 395+90 to Station 399+02

**Basic Dispersion**

- TDA 37 – C-Line Station 385+40 to Station 390+20
- TDA 41 – C-Line Station 400+00 to Station 401+50 and  
C-Line Station 401+94 to Station 402+30
- TDA 47 – C-Line Station 408+27 to Station 410+83 and  
C-Line Station 411+06 to Station 411+72 and  
C-Line Station 412+07 to Station 413+15
- TDA 48 – C-Line Station 413+46 to Station 418+54
- TDA 49 – C-Line Station 420+25 to Station 424+20
- TDA 52 – D-Line Station 426+34 to Station 431+63

Flow control performance standards and exemptions are presented in Section 4.3.

**Table 4-1. Land Use Summary**

TDA	Station	Station	Pre-developed Outwash Forest (acre)	Pre- developed Till Forest (acre)	Developed Till Grass (acre)	Developed Impervious (acre)	Flow Control Exception Met?
10	283+00	287+75	0.17	-	-	0.17	YES
11	287+75	295+85	0.32	-	-	0.32	NO <sup>1</sup>
12	295+85	300+25	-	0.18	-	0.18	YES
13	300+25	304+65	-	0.17	-	0.17	YES
14	304+65	308+25	-	0.15	-	0.15	YES
15	308+25	309+25	-	0.04	-	0.04	YES
16	309+25	311+00	-	0.07	-	0.07	YES
17	311+00	312+90	-	0.08	-	0.08	YES
18	312+90	314+00	-	0.05	-	0.05	YES



**Table 4-1. Land Use Summary (continued)**

TDA	Station	Station	Pre-developed Outwash Forest (acre)	Pre- developed Till Forest (acre)	Developed Till Grass (acre)	Developed Impervious (acre)	Flow Control Exception Met?
19	314+00	316+40	-	0.10	-	0.10	YES
20	316+40	323+90	-	0.31	-	0.31	NO <sup>2</sup>
21	323+90	328+26	-	0.18	-	0.18	NO <sup>2</sup>
22	328+26	333+90	0.23	-	-	0.23	NO <sup>2</sup>
23	333+90	338+00	0.16	-	-	0.16	YES
24	338+00	342+00	0.15	-	-	0.15	YES
25	342+00	347+50	-	0.23	-	0.23	NO <sup>2</sup>
26	347+50	349+90	-	0.1	-	0.1	YES
27	349+90	351+25	-	0.06	-	0.06	YES
28	351+25	353+27	-	0.09	-	0.09	YES
29	353+27	359+75	-	0.28	0.09	0.19	YES <sup>3</sup>
30	359+75	361+15	-	0.06	-	0.06	YES
30A	361+15	362+16	-	0.04	-	0.04	YES
31	362+16	365+75	-	0.16	-	0.16	YES
32	365+75	367+75	-	0.09	-	0.09	YES
33	367+75	371+00	-	0.14	-	0.14	YES
BREAK IN STATIONING							
34	371+50	378+80	-	0.33	0.15	0.18	YES <sup>3</sup>
35	378+80	382+00	-	0.14	-	0.14	YES
36	382+00	385+30	-	0.15	-	0.15	YES
SE 8 <sup>TH</sup> STREET – WWHM SCALE FACTOR CHANGE							
37	385+30	390+35	-	0.20	0.09	0.11	YES <sup>3</sup>
38	390+35	391+85	-	0.06	-	0.06	YES
39	391+85	393+30	-	0.06	-	0.06	YES
40	393+30	395+80	-	0.10	-	0.10	YES
41	395+80	402+30	-	0.27	0.10	0.17	YES <sup>3</sup>
42	402+30	403+50	0.05	-	-	0.05	YES
43	403+50	405+40	0.07	-	-	0.07	YES
44	405+40	405+60	0.01	-	-	0.01	YES
45	405+60	406+68	0.07	-	-	0.07	YES
46	406+68	408+15	0.06	-	-	0.06	YES
47	408+15	413+30	-	0.24	0.09	0.15	YES <sup>3</sup>
48	413+30	418+60	-	0.20	0.08	0.12	YES <sup>3</sup>

**Table 4-1. Land Use Summary (continued)**

TDA	Station	Station	Pre-developed Outwash Forest (acre)	Pre- developed Till Forest (acre)	Developed Till Grass (acre)	Developed Impervious (acre)	Flow Control Exception Met?
BREAK IN STATIONING							
49	419+10	424+20	-	0.21	0.08	0.13	YES <sup>3</sup>
50	424+20	424+75	-	0.02	-	0.02	YES
51	424+75	426+35	-	0.06	-	0.06	YES
52	426+35	431+70	-	0.21	0.10	0.11	YES <sup>3</sup>
53	431+70	434+50	-	0.15	-	0.15	YES
54	434+50	441+10	-	0.27	-	0.27	NO <sup>2</sup>
55	441+10	444+30	-	0.12	-	0.12	YES
56	444+30	448+66	-	0.17	-	0.17	YES
57	448+66	450+70	-	0.16	-	0.16	YES
58	450+70	453+95	-	0.14	-	0.14	YES
59	453+95	454+65	-	0.03	-	0.03	YES
60	454+65	456+30	-	0.07	-	0.07	YES
60A	456+30	458+65	-	0.10	-	0.10	YES
61	458+65	461+00	-	0.10	-	0.10	YES
62	461+00	464+50	-	0.15	-	0.15	YES
63	464+50	467+00	-	0.10	-	0.10	YES

1 Use infiltration facility proposed to meet flow control requirements

2 Trail runoff in this TDA is collected in a conveyance system that satisfies direct discharge exemption

3 Land Use Credits Applied

## 4.2.2 Developed Drainage and Flow Characteristics

Runoff from the trail will sheet flow off the paved trail surface to the adjacent gravel shoulders, with flow directed to the east or west depending on existing drainage features and other design considerations such as the location of conveyance systems or retaining walls. In general, runoff will follow the same flow paths as existing conditions. However, there are locations where the flow characteristics will be modified. This section discusses the TDAs where the proposed drainage is different from the existing flow patterns.

### TDAs 11 and 12

For TDA 11, the existing trail runoff is collected in a shallow ditch on the east side of the trail that conveys south to a culvert that crosses beneath the trail near Sta. 290+29. For TDA 12, the existing trail runoff is collected in a shallow ditch on the east side of the trail that conveys north and enters a private drainage system located at the private access crossing near Sta. 299+00. Trail improvements in TDA 11 require flow control. The proposed drainage design will collect and convey trail runoff from the private access crossing near Sta. 299+00 to approximately Sta. 288+75 via underdrain conveyance. The collected runoff will be fully infiltrated in a buried infiltration facility. The facility is described in Section 4.4 Flow Control System, and the conveyance is described in Section 5.4 Underdrain Conveyance.

## TDA 19 and 20

For TDA 19, the existing tail runoff is collected in a ditch on the east side of the trail that conveys north toward Unnamed Stream 4. For TDA 20, the existing tail runoff is collected in a ditch on the east side of the trail that conveys south toward Unnamed Stream 5. Trail improvements in TDA 20 require flow control. The proposed drainage design will collect and convey trail runoff from the private access crossing near Sta. 320+31 and convey south via an underdrain trench to Sta. 314+46. At Sta. 314+46 the conveyance system will connect to a private drainage system that is designed for direct discharge to Lake Sammamish. Direct discharge outfalls to Lake Sammamish are exempt from flow control, therefore, the proposed design meets flow control requirements for TDA 20. The conveyance is described in Section 5.4 Underdrain Conveyance, the direct discharge is described in Section 5.5 Conveyance Pipes.

## TDA 20, 21, and 22

For TDA 20, the existing tail runoff is collected in a ditch on the east side of the trail that conveys south toward Unnamed Stream 5. For TDA 21, the existing tail runoff is collected in ditches on both west and east sides of the trail that convey north where the ditch enters stacked PVC pipes near Sta. 327+00. The downstream ends of the pipes could not be found, but they are assumed to directly discharge to Lake Sammamish. For TDA 22, the existing trail runoff sheet flows west over the slope to Lake Sammamish. Trail improvements in TDAs 20, 21, and 22 all require flow control. To meet flow control requirements, the proposed drainage design will collect and convey trail runoff from the south end near Sta. 320+66 and north end near Sta. 333+89 and convey to a new drainage structure at Sta. 327+66. From this drainage structure, a new outfall is proposed that meets requirements for direct discharge to Lake Sammamish. Direct discharge outfalls to Lake Sammamish are exempt from flow control, therefore, the proposed design meets flow control requirements for TDAs 20, 21, and 22. The underdrain conveyances for this systems is described in Section 5.4 Underdrain Conveyance, the storm drain and direct discharge for this system is described in Section 5.5 Conveyance Pipes.

## TDA 25

For TDA 25, the existing trail runoff sheet flows west over the existing vegetated slope to Lake Sammamish. Trail improvements in TDA 25 require flow control. To meet flow control requirements, the proposed drainage design will collect and convey trail runoff to a new direct discharge outfall near Sta. 342+00. Underdrain conveyance will convey runoff from Sta. 347+50 to a new drainage structure near Sta. 342+00. From the structure an outfall pipe is designed to meet direct discharge requirements. Direct discharge outfalls to Lake Sammamish are exempt from flow control, therefore, the proposed design meets flow control requirements for TDA 25. The conveyance and direct discharge for this systems is described in Section 5.4 Underdrain Conveyance.

## 4.3 Performance Standards

A Level 2 flow control standard applies to this project according to City Ordinance 02011-304, Title 13 Surface Water Management. The Level 2 flow control performance standard requires flow control facilities to match developed discharge durations to pre-developed durations for the range of pre-developed discharge rates from 50 percent of the 2-year peak flow up to the full 50-year peak flow. Also, the facilities would match developed peak discharge rates to pre-developed peak discharges rates for the 2- and 10-year return periods. For land use, the historical site condition (forest) is assumed as the pre-developed condition.

Section 1.2.3.1.B of the 2009 KCSWDM also provides exemptions that apply to the Level 2 flow control standard. The flow control facility requirement is waived if the difference in the 100-year peak runoff flow rate ( $\Delta Q_{100}$ ) between the developed site condition and the historical site condition does not exceed 0.1 cfs. The runoff increase in each TDA was checked to see if it met the exception. Hydrologic modeling was performed using the Western Washington Hydrology Model 2012 (WWHM2012) Version 4.2.12 Dated 5/12/2016.

There are two different precipitation factors within the project area. The precipitation factor south of SE 8<sup>th</sup> Street is 1.167; and north of SE 8<sup>th</sup> is 1.0. SE 8<sup>th</sup> Street is located within the project vicinity at approximately trail C-Line station 385+25. Therefore, the amount of new impervious surface area that results in a 0.1 cfs increase differs in these two areas and also differs depending on soil type. The new impervious surface areas that resulted in a maximum increase of 0.1 cfs are presented in Table 4-2.

**Table 4-2. Flow Control Facility Exemption Summary**

Location	Soil Type	New Impervious Surface (acre)	Developed flow rate (cfs)	Predeveloped flow rate (cfs)	Q100 Difference (Developed – Predeveloped) (cfs)
South of SE 8 <sup>th</sup> Street	A/B forest, flat	0.17	0.10	0.00	0.10
(C-Line Sta. 385+25)	C, forest, flat	0.20	0.12	0.02	0.10
North of SE 8 <sup>th</sup> Street	A/B forest, flat	0.19	0.10	0.00	0.10
	C, forest, flat	0.21	0.11	0.01	0.10

Table 4-1 above summarizes the predeveloped and developed land uses for target areas within each TDA and provides indication whether the TDAs is meets the flow control exception based on the land use and hydrologic modeling summary presented in Table 4-2. Table 4-1 also indicates the TDAs where land use credits were used for the land use entered in to the model based on the FCBMPs applied to the target impervious surfaces. The FCBMPS are described further in Section 4.4.

The WWHM4 model printouts for the four flow control facility exemption land use scenarios are included in Appendix C2.

## 4.4 Flow Control System

The proposed design includes one infiltration facility to meet flow control requirements, and thirteen FCBMPs to promote infiltration and reduce trail surface runoff. The infiltration facility is an underground infiltration chamber that is designed to fully infiltrate contributing runoff. The FCBMPs include three infiltration trenches for limited infiltration and nine basic dispersion areas. This section describes the flow control facilities and FCBMPs.

### Infiltration Chamber – TDA 11 – B-Line Sta. 287+75 to Sta. 288+75

As indicated in Table 4-1, trail improvements in TDA 11 require flow control. The design team proposes to install a buried infiltration chamber that consists of corrugated polypropylene pipe arches placed on top of 9-inches of clean crushed angular stone. The pipe arches and the clean crushed stone provide the storage space while the collected runoff infiltrates through the native soils. The system was designed using the StormTech MC-3500 Chamber System.

The infiltration chamber system consists of 12 pipe arches, 2 end caps, 9-inches of clean crushed stone at the base and 12-inches of clean crushed stone over the top of the pipe arches. Each pipe arch is 77-inches wide by 45-inches high by 86-inches long (installed). Each end cap is 77-inches wide by 45-inches high by 25.7-inches long. The infiltration chamber is presented on sheet DD2 of the design plans provided in Appendix A.

The infiltration facility was sized using WWHM2012 with the 1-hour time step. To properly account for area and storage volume of the StormTech MC-3500 Chamber, the facility was designed using a stage, storage, discharge (SSD) table design spreadsheet tool provided by StormTech. The infiltration facility size was designed using the 10-inches-per-hour long-term (design) infiltration rate recommended by Icicle Creek Engineers, Inc. in the Draft Geotech Report.

WWHM2012 model calculations and stage storage discharge spreadsheet calculations of the infiltration chamber are provided in Appendix C2.

### Flow Control Best Management Practices (Low Impact Development)

As discussed in Section 2.1, this project is a railroad right-of-way; therefore, under Section 5.2 of the 2009 KCSWDM, the implementation of flow control best management practices (FCBMPs) is incentive-based and optional. The project design proposes to incorporate infiltration trenches and basic dispersion areas FCBMPs as described in this section.

#### **Limited Infiltration (Infiltration Trenches)**

Infiltration trenches are designed along the trail in various locations that are suitable for limited infiltration based on the design requirements provide in Sections C.2.2 and C.2.3 of the 2009 KCSWDM.

Infiltration trench locations are listed below and shown on the design plans (Appendix A):

- Trench 1            TDA 29 – B-Line Sta. 355+40 to Sta. 359+75
- Trench 2            TDA 34 – C-Line Sta. 371+71 to Sta. 378+80
- Trench 3            TDA 41 – C-Line Sta. 395+90 to Sta. 399+02

The gravel infiltration trenches are located under the 2-foot-wide gravel shoulder. A 6-inch thick, clean ¾-inch gravel layer will be used to collect the runoff from the trail and allow it to percolate down into the gravel storage area below. The storage depth of the trenches is typically 2 feet deep with an additional 6 inches of freeboard below the surface of the trail.

The trench characteristics are provided below:

- Trench dimensions:
  - Length to match the trail or sidewalk length for above listed station ranges
  - Width: 2 feet
  - Depth: 2 feet
  - Void Space: 30 percent

As described in Section 1.2, Icicle Creek Engineering, Inc. prepared a geotechnical report that includes all soil borings taken throughout the project. The boring logs provide soil type and groundwater depth in the areas where infiltration trenches are proposed. Borings B-34, B-35, B-37 and B-96 were taken in the vicinity of Trench 1. Borings B-43, B-44, and B-45 were taken in the vicinity of Trench 2. Boring B-51 was taken in the vicinity of Trench 3.

For the most part, the groundwater is sufficiently deep that the typical trench configuration will meet the required 3 feet of vertical separation above the seasonal high water table.

The underlying soils for Trench 1 are fine to medium sand with silt content sandy with high silt content at depths 3 to 10 feet below ground surface. The borings extended at least 16.5 feet below ground surface and groundwater was encountered between 3 and 7 feet below ground surface. The bottom of the gravel trench will be 1 foot from the groundwater surface level.

The underlying soils for Trench 2 are fine to medium sand with silt content sandy with high silt content at depths to 5 feet below ground surface, and find sand with gravel below that. The borings extended to at least 11 feet below ground surface and as deep as 16.5 feet below ground surface. Groundwater was encountered between 4 and 7 feet below ground surface. The bottom of the gravel trench will be 1 foot from the groundwater surface level.

The underlying soils for Trench 3 are fine to medium sand with gravel and high silt content at depths 2 to 15 feet below ground surface. The borings extended to 15.3 feet below ground surface and groundwater was encountered at 10 feet below ground surface. The bottom of the gravel trench will be greater than 1 foot from the groundwater surface level.

#### ***Limited Infiltration (Underdrain Trenches)***

Approximately 3,700 linear feet of underdrain trenches will provide limited infiltration of trail runoff. These areas have poor soils and no ditches; therefore, trenches with underdrains will be used to capture and convey runoff to an infiltration chamber or drainage structure. Although not designed for infiltration, the trenches will likely provide limited infiltration. Underdrain trenches are located at the following locations:

- B-Line Sta. 288+76 to Sta. 298+38
- B-Line Sta. 314+46 to Sta. 320+31
- B-Line Sta. 327+66 to Sta. 333+89
- B-Line Sta. 341+99 to Sta. 347+50
- B-Line Sta. 351+26 to Sta. 353+23
- B-Line Sta. 353+28 to Sta. 355+00
- D-Line Sta. 450+72 to Sta. 452+46
- D-Line Sta. 452+50 to Sta. 453+93
- D-Line Sta. 453+97 to Sta. 455+75
- D-Line Sta. 456+35 to Sta. 457+55

#### ***Basic Dispersion***

Basic dispersion areas are designed along the trail in areas where the slope of the vegetated flow path is 15 percent or less. The trail will sheet flow over the gravel shoulder and 10 feet of vegetated flow path for the trail impervious surface that is no greater than 20 feet wide.

- Basic Dispersion
  - TDA 37 – C-Line Station 385+40 to Station 390+20
  - TDA 41 – C-Line Station 400+00 to Station 401+50 and  
C-Line Station 401+94 to Station 402+30
  - TDA 47 – C-Line Station 408+27 to Station 410+83 and  
C-Line Station 411+06 to Station 411+72 and  
C-Line Station 412+07 to Station 413+15
  - TDA 48 – C-Line Station 413+46 to Station 418+54

- TDA 49 – C-Line Station 420+25 to Station 424+20
- TDA 52 – D-Line Station 426+34 to Station 431+63

**Soil Amendment**

This project will comply with the City of Sammamish’s Soil Amendment Requirement for all disturbed pervious areas adjacent to the trail in accordance with Section 1.2 of the City of Sammamish Solid Waste Design Manual Addendum.

Wetland and stream buffer enhancement mitigation is proposed adjacent to the trail. No grading is proposed for these areas. Instead, “mitigation clearing and grubbing” is specified for these areas. This entails selectively removing roots of unwanted vegetation, while leaving as much topsoil in place as possible. Areas with selective clearing of invasive species, such as knotweed, will receive a 3-inch layer of fine compost prior to planting followed by a 3-inch layer of mulch. These areas will not be tilled due to the risk of spreading invasive species.

Other mitigation planting areas will receive 3 inches of compost tilled into the top 10 inches followed by 1 inch of compost prior to planting and 3 inches of mulch over the entire planting area.

## 4.5 Water Quality System

The new trail surface will be non-PGIS. The trail does cross a number of private driveways, which are PGIS, and all driveway surfaces will be replaced at the proposed trail grade. The project also proposes to remove PGIS and add new PGIS in areas where there is opportunity to remove vehicle crossing of the trail. Water quality treatment is required for each TDA with new and replaced PGIS areas greater than 5,000 square feet.

For this project, new and replaced PGIS and new and replaced minus removed PGIS total less than 5,000 square feet within each TDA; therefore, runoff treatment is not required. New plus replaced and removed PGIS are summarized in Table 4-6. Figures 4-1 through 4-7 depict the PGIS changes for each driveway, and include a summary of new, replaced, and removed PGIS areas for each TDA. Driveways 14, 16, 18, and 19 were removed to reduce vehicle crossings of the trail. To maintain property access where driveways from East Lake Sammamish Parkway were removed, new driveway connections (new PGIS) are proposed. These are shown in Figures 4-4, 4-5 and 4-6 for driveways 16, 18, and 19.

**Table 4-6. Proposed New plus Replaced PGIS Summary**

TDA	Driveway	New plus Replaced PGIS (sq ft)	Removed PGIS (sq ft)	Total PGIS Change (sq ft)
12	2	1,069	-	1,069
14	3	1,721	-	1,721
20	5	969	-	969
21	6	751	-	751
23	7A	1,006	-	1,006
24	7B	1,476	-	1,476
29	8	643	-	643
34	9	1,935	-	2,220
	10	285	-	

**Table 4-6. Proposed New plus Replaced PGIS Summary (continued)**

TDA	Driveway	New plus Replaced PGIS (sq ft)	Removed PGIS (sq ft)	Total PGIS Change (sq ft)
35	10	396	-	3,938
		3,542		
36	11	676	-	676
37	11	831	-	1,651
	12	820	-	
38	13	370	-	370
39	13	766	-	334
	14	-	432	
40	14	-	478	-81
	15	397	-	
41	15	626	-	
	16	827	1,197	278
	17	367	-	
	18	-	345	
42	17	826	-	826
45	18	1,066	-	1,066
46	18	-	200	-200
47	18	-	548	
	19	1,534	655	1,079
	20	748	-	
48	20	1,045	-	1,262
	21	217	-	
49	21	117	-	117
50	21	66	-	699
		633	-	
54	22	908	-	908
55	23	367	-	367
56	23	668	-	668
57		2,797	-	2,797
61	24	2,368	-	2,368



## 5. CONVEYANCE SYSTEM ANALYSIS AND DESIGN

There are three types of conveyance systems within the project area—culverts, ditches, and conveyance pipes—that will be affected by construction of this project. Ditches parallel the trail throughout the corridor, and culverts cross the trail to convey water from ditches, wetlands, and streams east to west. In general, both culverts and ditches affected by the project will be replaced in kind. Conveyance systems are present throughout the project corridor, but many of the existing conveyance systems or private drainage systems that either cross beneath the trail and discharge to Lake Sammamish, or they are located downstream of the trail and provide collection for runoff from the private access roads located west of the trail. Conveyance calculations were not performed for systems that were replaced in kind, unless the system had documentation of drainage problems.

If a ditch is completely filled in, an underdrain is proposed to convey trail runoff to the trail discharge location. New conveyance systems were sized using the Rational Method to size the conveyance system for the 25-year design storm. The Rational Method calculations were performed using the Storm Sewer Design calculator spreadsheet, a design tool developed by the Washington State Department of Transportation (WSDOT). If a conveyance system needed to evaluate conveyance capacity with contributing flows from offsite, upstream contributing areas, then the contributing areas were entered into the MGSFloodV4 hydrologic model to generate contributing flows. The peak flow rates calculated by MGSFloodV4 were then used in the conveyance sizing calculations. Hydraulic calculations are provided in Appendix C.

Culverts that convey streams beneath the trail were evaluated to determine if the streams had historic fish presence, and which fish passage barrier culverts would be replaced with fish passable culverts. Fish passage culverts are discussed in Section 5.2.

### 5.1 Culverts

Twenty-nine existing culverts cross the proposed trail alignment. Each was evaluated for impacts related to the widening of the trail. If a culvert needed to be lengthened to accommodate fill, an analysis was performed to determine whether to replace or extend the culvert. Based on this analysis, two culvert will be replaced in kind (one with a catch basin added at the inlet), two culverts will be extended, four culverts will be replaced with a storm drainage system, one culvert will have a catch basin added at the inlet, and six culverts will be replaced with fish passage culverts (see Table 5-1 below). King County will continue to provide regular maintenance for all culverts along the trail corridor.

The criteria considered in the evaluation included the following:

- Replace the culvert if the following occurs:
  - Inlet or outlet is cracked or broken.
- Extend the culvert if the following occurs:
  - Material is metal, concrete, or high density polyethylene (HDPE).
  - Physical condition is good (no cracks).

Table 5-1 summarizes the project culverts and how the proposed design will treat each culvert crossing. A detailed discussion on fish passage culverts is provided in Section 5.2. A detailed hydraulic analysis was completed for the fish passage culverts, but not for any of the other culvert replacements because there are no existing capacity problems at those locations. Rather, the culverts are being replaced as a result of proposed trail impacts to at least one end of the pipe.

**Table 5-1. Summary of Existing Culverts and Proposed Action**

Station	Stream	Affected by Trail	Material	Action
290+30	No	Yes	Concrete	New catch basin and culvert
316+18	Unnamed Stream #4	No	Concrete	None
316+90	Unnamed Stream #5	No	CORR HDPE	Concrete headwall
320+75	No	Yes	CMP	Remove, Install conveyance system
324+75	No	No	CORR HDPE	Remove, Install conveyance system
350+40	No	No	CORR HDPE	None
352+50	No	Yes	Concrete	Install catch basin at culvert inlet
356+90	Unnamed Stream #6	No	CMP	None
361+60	No	No	PVC	Remove, Install conveyance system
364+25	No	No	Clay	None
367+00	Unnamed Stream #7	Yes	CORR HDPE	Extend and connect to conveyance system
371+20	No	No	Concrete	None
379+15	Pine Lake Creek	No	Concrete	Replace for Fish Passage
384+25	Unnamed Stream #8	Yes	CMP	Replace
386+60	Unnamed Stream #8	No	CMP	None
398+90	No	Yes	CORR HDPE	Remove
401+75	Stream #0155	No	Concrete	Replace for Fish Passage
411+90	Ebright Creek	No	Concrete	Replace for Fish Passage
424+60	Zaccuse Creek	No	Concrete	Replace for Fish Passage
424+60	Unnamed Stream #9	No	Concrete	No
436+30	No	No	CORR HDPE	Replace, connect to conveyance system
441+40	George Davis Creek	No	Concrete	Replace for Fish Passage
448+40	No	No	CORR HDPE	Replace, connect to conveyance system
449+95	Unnamed Stream #10	No	Concrete	None
452+90	Unnamed Stream #11	No	CORR HDPE	None
455+80	Unnamed Stream #13	Yes	Concrete	Extend existing culvert
456+45	No	No	CORR HDPE	None
460+25	Stream #0143L	No	Concrete	None
464+30	Stream #0143L	No	Concrete	Replace for Fish Passage

The existing 24-inch concrete culvert at Sta. 290+30 will be replaced with a Type 2 catch basin and a new 24-inch corrugated HDPE culvert. The catch basin will be installed at the base of a steep ditch to reduce localized erosion that is evident at the embankment of the trail where the ditch makes 90-degree turn to parallel the trail and around the inlet of the existing culvert. The culvert will outfall to the west at the same location as the existing culvert.

The existing 8-inch culvert at Sta. 320+75 and existing 12-inch culvert at Sta. 324+75 were connected to wetland ditches on both sides of the trail that flowed north along the east ditch. These culverts and ditches will be replaced with a conveyance system consisting of underdrain trenches in the east trail shoulder and 12-inch conveyance system with catch basins structures and a discharge location at Sta. 327+75. The drainage system will convey north and directly discharge to Lake Sammamish via a new outfall near Sta. 327+65. The underdrain and tightline conveyance systems are discussed further in Sections 5.4 and 5.5, respectively.

The inlet to the existing 12-inch concrete culvert at Sta. 352+50 is will be modified to include a catch basin structure to account for the proposed grading that will fill the ditch on the east side of the trail. The underdrain system is discussed further in Sections 5.4.

The existing 8-inch PVC culvert at Sta. 361+60 is being replaced with a catch basin and tighline conveyance system. The purpose of installing an enclosed drainage system is to improve an existing drainage problem downstream of the trail on East Lake Sammamish Shore Lane SE. The conveyance system is discussed further in Sections 5.5.

The existing 12-inch ADS culvert at Sta. 367+00 will be extended on the west culvert end and connect to a new storm drain manhole to be located at the edge of East Lake Sammamish Shore Lane SE. The purpose of this modification is to accommodate the short retaining wall that will be installed west of the trail. The conveyance system is discussed further in Sections 5.5.

The existing 12-inch CMP culvert at Sta. 384+25 will be replaced with a 24-inch concrete culvert. The existing culvert does not have capacity problems, therefore, no design calculations were performed. However, the new culvert will consist of stronger material and increased capacity to reduce potential maintenance problems in the future.

The existing 8-inch ADS culvert at Sta. 398+90 will be removed and not replaced because an infiltration trench is proposed in the west trail shoulder to reduce trail runoff.

The existing 12-inch CMP culvert at Sta. 436+30 will be replaced with a culvert that is connected to a new tighline conveyance system. The new conveyance system will install two catch basins in East Lake Sammamish Shore Lane NE, and will flow west and directly discharge to Lake Sammamish on the private property at 439 East Lake Sammamish Shore Lane NE. The conveyance system is discussed further in Section 5.5.

The existing 12-inch concrete culvert located in the Wetland 28E east of the trail conveys runoff north. The culvert was partially plugged with sediment, and was up-plugged by King County Parks maintenance staff in the spring of 2016. Once un-plugged, the pipe was TV'd to assess the pipe condition and flow path direction. The culvert was identified to turn west near Sta. 448+40 in an 8-inch ADS pipe. This pipe discharges to a planting bed located below the trail to the west. The design proposes a new conveyance system consisting of 12-inch storm drain pipe and six catch basin structures that will convey runoff from Wetland 28E north, and cross beneath the trail near Sta. 448+40. The proposed system will not discharge to the open planting bed, but instead is proposed to directly discharge to Lake Sammamish via a drainage easement located along the north property boundary of 833 East Lake Sammamish Parkway. The conveyance system is discussed further in Section 5.5.

The existing 24-inch concrete culvert at Sta. 455+80 will be extended at the inlet end to accommodate trail widening. No conveyance capacity calculations were performed because the contributing are did not change.

## 5.2 Fish Passage Mitigation

A screening analysis was conducted for all of the water crossings within the limits of this project to determine which structures need to be replaced with fish passable structures. The technical memorandum (Parametrix, 2015) was provided to the Muckleshoot Indian Tribe (MIT) for review and is presented in Appendix D. Out of the 32 water crossings along this segment of the trail, eight streams pass the replacement screening criteria described in the memo. Two of the streams (#0163 S and #0163 N) are in South Sammamish Segment A. The culverts on these two streams were not replaced because of limited habitat gain without other fish blockage removals outside the trail corridor. Instead, two

additional structures will be replaced within the Segment B project – one additional culvert downstream of the trail on Pine Lake Creek and one on Zaccuse Creek downstream of the trail.

The eight culverts that will be replaced with fish passage concrete box culverts include:

- Pine Lake Creek (at trail crossing) (Sta. 379+14)
- Pine Lake Creek (downstream of the trail)
- Stream #0155 (Sta. 401+75),
- Ebright Creek (Sta. 411+90)
- Zaccuse Creek (at trail crossing) (Sta. 424+60)
- Zaccuse Creek (at Shore Lane)
- George Davis Creek (Sta. 441+40),
- Stream #0143L (Sta. 464+28).

Stream and culvert designs were completed following the Stream Simulation Design Option from the Water Crossing Design Guidelines (WDFW 2013).

Culvert span was determined using the following calculation:

$$W_{CB} = 1.2 * W_{ch} + 2', \text{ where } W_{CB} = \text{Culvert bed width in feet and } W_{ch} = \text{Bankfull channel width}$$

Fish passage culverts will be four-sided concrete box culverts. The bottom of the box will be countersunk a minimum of 2 feet at the downstream end of the culvert for streambed sediment, and have at least 2 feet of freeboard above the full flow capacity of the existing stream culvert. The culvert and stream slope were designed to have a slope ratio up to 1.25 times the upstream channel slope. The slope ratio is the upstream channel slope divided by the streambed slope through the culvert. Culvert lengths are all about 19 feet long and will maintain the trail cross-sectional width. Wingwalls, where proposed, will provide for smooth transitions between the culvert and the existing ground or structural earth walls. Finally, culvert rises were designed for the concrete lid to serve as the base of the trail surfacing material. A 10-inch-wide by 12-inch-tall concrete curb will be placed at the culvert ends to ensure that the surfacing material does not ravel off into the streams.

The contributing basin areas for each of the streams is at least 100 acres, therefore, the continuous hydrologic model, MGSFloodV4, was used with the 5-minute time step to calculate the peak flow rates for the design storm events. The contributing drainage basins were delineated using GIS data (contours, City of Sammamish drainage system elements, etc.) and the total areas are identified on Figures 3-1 through 3-9. A land use analysis was completed using City zoning to determine the various land types of the contributing drainage basins to each stream. A hydraulic analysis of each stream box culvert using 25-year and 100-year peak flow rates calculated by MGSFloodV4. The hydraulic analysis of flow through the box culverts was completed using HY-8, a culvert hydraulic analysis and design software developed by the Federal Highway Administration (FHWA).

All of the above described land use, hydrologic and hydraulic calculations used to size the fish passage culverts are provided in Appendix C3. A description of each stream crossing is provided below.

#### Pine Lake Creek (at the trail)(Sta. 379+14)

Pine Lake Creek is a Category 1 Stream and a primary Kokonee spawning stream (Lake Sammamish Kokanee Work Group 2014). Replacing these two culverts near the mouth of Lake Sammamish will enhance access to spawning habitat in the upstream reaches.

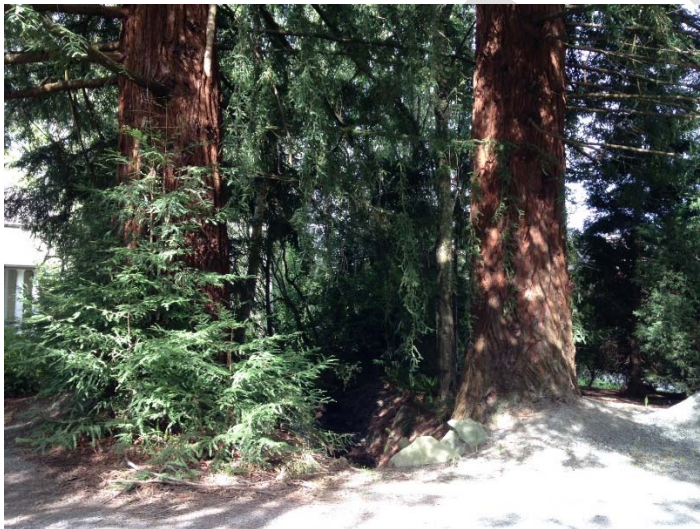
The existing twin 36-inch concrete culverts are each 32 feet long. The culverts will be replaced by a precast reinforced split box culvert. Pine Lake Creek has an average measured bankfull width of 10.2

feet, and the stream has slopes of approximately 2.5 percent downstream of the culvert. The new culvert will be a 14 feet wide, 7 feet high, and 19 feet long. The reduced culvert length of the new culvert will increase the length of open channel stream by 13 feet. The invert of the culvert will be countersunk, and the streambed slope will be approximately 1.5 percent through the culvert.

#### Pine Lake Creek (downstream of trail)

This segment of the stream is on private property and is not within the trail corridor. The existing culvert is being replaced in lieu of Stream #0163 S, which is located in the ELST South Sammamish Segment A project. The existing culvert is a single 36" diameter concrete culvert that is 41 feet long with a slope of 0.76 percent. The culvert will be replaced by a 32-foot long box culvert with a 14-foot span and a height of 7 feet. The reduced culvert length of the new culvert will increase the length of open channel stream by 9 feet. The invert of the culvert will be countersunk, and the streambed slope will transition from 2.91 percent at the culvert inlet to 0.22 percent through the culvert until matching existing grade approximately 20 feet downstream of the culvert outlet.

There are two 6-foot diameter redwood trees flanking either side of the existing culvert on the downstream end. These two trees will be preserved at the request of the homeowners. As a result the new culvert will have to shift to the east of its existing location approximately 6 feet on the upstream end. The downstream side will open up approximately 15 feet of new channel, although because of the close proximity of the trees, will not be a full width channel.



#### Stream #0155 (Sta. 401+75)

The existing culvert that conveys Stream #0155 under the trail is a 16-inch ADS pipe. On the east side of the trail, water flows into the top of a type 2 catch basin with a birdcage top. On the west side of the trail, the pipe connects into a type 2 catch basin with a solid lid. From there, the creek is conveyed to the lake through a 20-inch pipe. The proposed fish passage box culvert would be 19-feet long. The two catch basin structures on either side of the trail would be removed. The catch basin rim on the east side provides a constant overflow elevation for the adjacent wetland. This function will be replaced by adding in a rock weir around the entrance to the new culvert. Approximately 9-feet of channel will be opened on the east side. On the west side, the channel will be opened up approximately 10 feet to the adjacent driveway. A short retaining wall will be installed along the edge of the driveway to protect the embankment and allow for the short section of open channel between the trail and the driveway.

The bankfull width of Stream #0155 is approximately 5 feet and the proposed box culvert will be 8-feet wide by 8-feet tall. The streambed slope through the culvert is approximately 2.8 percent, matching the stream channel elevation on the east end and the assumed pipe invert on the west end.

### Ebright Creek (Sta. 411+90)

Ebright Creek currently crosses under the trail in twin 36-inch concrete culverts, one 34 feet long and the other is 37 feet. Ebright Creek is a Category 1 stream and a primary Kokanee spawning stream (Lake Sammamish Kokanee Work Group 2014). Replacing the twin culverts under the trail will allow fish to more easily access their spawning habitat upstream of the trail.

Ebright Creek has an average measured bankfull width of 8.9 feet with an average slope downstream of the trail of 2.7 percent. The new box culvert will have a 14-foot span, a height of 7 feet and a length of 19 feet, thereby increasing the length of open channel by 18 feet. Additionally, approximately 13 feet of stream will be re-graded at the culvert outfall. The short re-grade will improve the stream profile by allowing the culvert slope to remain similar to existing conditions, and removing the potential of a perched culvert end. The streambed slope will be 1.8 percent through the culvert.

### Zaccuse Creek (Sta. 424+60)

Zaccuse Creek is a Category 3 stream – a secondary stream that has potential for kokanee spawning. There are three culverts close to the mouth of the creek that together likely impede fish passage under some or all conditions during the spawning season (Lake Sammamish Kokanee Work Group 2014).

R2 Resource Consultants, Inc. prepared a technical memorandum, dated June 18, 2012, for replacement of the three culverts and realignment of approximately 200 feet of stream channel upstream of East Lake Sammamish Parkway. Parametrix performed field work to verify findings presented by R2 in the June 18, 2012 technical memorandum.

Zaccuse Creek has an average measured bankfull width of approximately 5.8 feet, which is rounded up to 6 feet for design purposes. R2 proposed culvert spans 10-feet wide, and an average re-graded stream slope of approximately 3.4 percent through the entire study reach (R2 Resource Consultants 2012). This culvert width and slope were used for design of the two culverts being constructed for this project.

The existing culvert that conveys Zaccuse Creek under the trail is 34 feet long 36-inch diameter concrete pipe. The new box culvert will have a 10-foot span, a height of 8 feet and a length of 19 feet, thereby increasing the length of open channel by 15 feet. Additionally, approximately 45 feet of open channel will be re-graded from the East Lake Sammamish Parkway culvert outlet to the inlet of the trail box culvert, and approximately 35 feet of open channel will be re-graded from the outlet of the trail box culvert to the inlet of the Shore Lane box culvert.

### Zaccuse Creek (downstream of trail at Shore Lane)

This segment of the stream is on private property at East Lake Sammamish Shore Lane Drive and is not within the trail corridor. The existing culvert is being replaced in lieu of Stream #0163 N, which is located in the ELST South Sammamish Segment A project. The existing culvert is a small bottomless concrete box with dimensions approximately 2-feet wide by 3-feet tall by 9.5 feet long.

The culvert will be replaced by a 12-foot long box culvert with a 10-foot span and a height of 5 feet. The extended culvert length of the new culvert will slightly decrease the length of open channel at this crossing, but will allow the road to continue to accommodate vehicular access to private properties. The invert of the culvert will be countersunk, and the streambed slope will continue at the re-graded slope of 3.4 percent.



## George Davis Creek (Sta. 441+40)

George Davis Creek currently crosses under the trail in a 36-inch concrete culvert that is 24 feet long and an 18-inch concrete culvert that is 18 feet long. George Davis Creek is a Category 3 stream that is not considered a critical for Kokanee spawning stream (Lake Sammamish Kokanee Work Group 2014). Kokanee spawners have intermittently returned to the accessible portion of the creek following a project that restored approximately 100 feet at the mouth of Lake Sammamish. After the first 100 feet of open channel, the stream enters an enclosed system that navigates steep slopes beneath two private properties and East Lake Sammamish Shore Lane for approximately 180 feet before daylighting west of the trail. Replacing the twin culverts under the trail will remove a fish barrier for fish that are able to navigate their way through to this point in the stream.

The stream has an average measured bankfull width of 10 feet, with moderate slopes upstream of East Lake Sammamish Parkway averaging 3.5 percent and steeper slopes downstream of East Lake Sammamish Shore Lane estimated up to 12 percent, where the stream is located in an enclosed pipe. The proposed design will install a 19-foot-long, 14-foot-span by 7-foot-rise concrete culvert. The culvert bed will be countersunk, and the streambed slope will be 1.2 percent through the culvert. The reduced culvert length will increase the length of open channel stream by 5 feet. Additionally, approximately 10 feet of stream will be re-graded at both the culvert inlet and outfall. The re-grade will provide a consistent channel section through the culvert crossing beneath the trail.

## Stream #0143L (Sta. 464+28)

The existing culvert that conveys Stream #0143L under the trail is a 34-foot long, 36-inch concrete pipe. On the east side of the trail, water flows north along in an open channel for approximately 320 feet at an average slope of 3 percent, before turning west and entering the existing concrete culvert. The existing culvert slope is approximately 6.9 percent, and the open channel downstream of the culvert averages 10 percent for approximately 50 feet before entering the lake.

The bankfull width of Stream #0143L is approximately 6 feet and the proposed box culvert will be 10-feet wide by 7-feet tall. The culvert bed will be countersunk, and the streambed slope will be approximately 5.9 percent.

The proposed fish passage box culvert would be 19-feet long. Approximately 9-feet of channel will be opened on the east side. On the west side, the channel will be opened up approximately 5 feet.

## 5.3 Ditches

In general, grading and walls were used to minimize the amount of fill placed in existing ditches located adjacent to the trail. Therefore, the conveyance function of most of the ditches along the corridor has been preserved. However, the proposed trail will fill some ditches. Table 5-2 identifies which ditches will be impacted and what conveyance action is proposed to provide conveyance for the project.

**Table 5-2. Summary of Affected Ditches and Proposed Design**

Station	Trail Impact	Action
292+25 to 298+20	Completely filled	Install underdrains for conveyance
320+80 to 325+00	Completely filled	Install conveyance system
351+50 to 355+00	Completely filled	Install underdrains for conveyance
395+91 to 399+02	Completely filled	Install infiltration trench
451+00 to 457+90	Partially and completely filled	Install underdrains for conveyance

Trail widening from Sta. 292+25 to Sta. 298+20 will fill in most of the existing ditch east of the trail. The project will install underdrains in the two foot gravel shoulder to provide conveyance for trail runoff to a new catch basin located in the trail shoulder at Sta. 289+76. The underdrain trench is discussed further in Section 5.4.

Trail widening from Sta. 320+80 to Sta. 325+00 will fill in the existing ditch west of the trail. The project will install conveyance system consisting of 12-inch diameter storm drain and five catch basins beneath the west shoulder and underdrains beneath the east shoulder. The conveyance system will flow north to Sta. 327+66 where the system will directly discharge to Lake Sammamish via a new outfall. The conveyance system is discussed further in Section 5.5.

Trail widening from Sta. 351+50 to Sta. 355+00 will fill in the existing ditch east of the trail. The project will install underdrains in the two foot gravel shoulder to provide conveyance for trail runoff to a existing drainage discharge locations. One connection will be to a new catch basin that will be connected to an existing culvert at Sta. 352+50. The other connection will be to the existing ditch north of the widening segment at Sta. 355+10. The underdrain trench is discussed further in Section 5.4.

Trail widening from Sta. 395+91 to Sta. 399+02 will fill in the existing shallow ditch west of the trail. The project proposes to install an infiltration trench in the west trail shoulder to reduce trail runoff, and remove the need for a drainage ditch.

From Sta. 451+00 to Sta. 457+90, existing trail runoff sheet flows west toward private properties and Lake Sammamish. On the east side of the trail, there are intermittent ditches, wetlands, and segments of stream that convey off-site runoff through the project site via various existing drainage system crossings. The design proposes to install underdrain trenches throughout this stretch to convey runoff to culvert or storm drain pipe crossings near Sta. 452+95, Sta. 454+55, Sta. 455+80, and Sta. 456+40. The underdrain systems are discussed further in Section 5.4.

## 5.4 Underdrain conveyance systems

Underdrains will be used to collect and convey trail runoff to existing trail discharge locations. The underdrains were sized using the Storm Sewer Design calculator spreadsheet, which uses the rational method and to size the conveyance system at the 25-year design storm. The underdrain sizes range from 6- to 8-inches and are sized the conveyance system to adequate pipe capacity at the 25-year design storm. The underdrain trenches will be located in the 2-foot-wide gravel shoulder of the trail at locations shown on the plans (Appendix A). Cleanouts will be installed at 100-foot intervals along the underdrain.

Underdrain trenches locations and downstream drainage system connections are as follows:

- Sta. 288+75 to Sta. 299+00 (TDAs 11 and 12) – convey south and connect to infiltration chamber near Sta. 288+75
- Sta. 314+46 to Sta. 320+31 (TDA 19 and 20) – convey south and connect to existing drainage system that directly discharges to Lake Sammamish near Sta. 314+50. Conveyance and direct discharge for this drainage system are discussed further in Section 5.5.
- Sta. 320+66 to Sta. 325+74 (TDAs 20 and 21) – collect runoff and connect to tight line conveyance system located under the west shoulder via catch basins at Sta. 322+99, Sta. 324+98, and Sta. 325+72. Conveyance system will discharge directly to Lake Sammamish via a new outfall pipe at Sta. 328+65. Conveyance and direct discharge for this drainage system are discussed further in Section 5.5.



- Sta. 333+89 to Sta. 328+65 (TDA 22) – convey south and connect to catch basin structure that discharges to Lake Sammamish at Sta. 328+65. Direct discharge for this drainage system is discussed at the end of this section.
- Sta. 347+50 to Sta 342+00 (TDA 25) – convey south and connect to catch basin structure that discharges to Lake Sammamish near Sta. 342+00
- Sta. 351+26 to Sta. 353+23 (TDA 28) – convey to catch basin that connects to existing drainage pipe located near Sta. 352+00
- Sta. 353+28 to Sta. 355+09 (TDA 29) – convey north and discharge to existing drainage ditch east of trail near Sta. 355+10
- Sta. 448+66 to Sta. 448+40 (TDA 56) – convey south and discharge to drainage structure near Sta. 448+40
- Sta. 450+72 to Sta. 453+93 (TDA 58) – convey to catch basin that connects to existing drainage pipe located near Sta. 452+91
- Sta. 453+97 to Sta. 455+75 (TDA 59)– convey to inlet end of Unnamed Stream #13 near Sta. 455+80
- Sta. 456+30 to Sta. 457+90 (TDA 60A) – convey to new catch basin that connects to existing drainage pipe located near Sta. 456+40 that conveys runoff west and discharges to Lake Sammamish through a concrete bulkhead located on property at 1111 East Lake Sammamish Parkway NE

Conveyance calculations spreadsheets are provided in Appendix C.

#### ***Direct Discharge – TDA 25***

The new outfall meets direct discharge requirements per Section 1.2.3 of the 2009 Manual (page 1-37) as follows:

- a) The conveyance system discharges to Lake Sammamish.
- b) The conveyance system will extend to the ordinary high water mark (OHWM) of Lake Sammamish, will be comprised of 12-inch storm drain pipe and a rock lined ditch, and will be located within the project property boundary.
- c) Conveyance calculations (Appendix C) demonstrate that the conveyance system has enough capacity to convey the build-out condition of the contributing area (trail is the only contributing area).
- d) The conveyance system will be enclosed pipes and the outfall will have a rock lined ditch for erosion protection as the system connects to the Lake Sammamish OHWM.
- e) The existing trail sheet flows west toward the lake, but trail improvements in this TDA require flow control. The proposed wall limits the ability for the project to use basic dispersion as a FCBMP and the underlying soils limit the ability to use limited infiltration as a FCBMP. Therefore, the project design proposes to convey trail runoff to a new direct discharge outfall to Lake Sammamish. The proposed design will not divert flows from an existing wetland or stream, nor will it not cause significant adverse impact to a wetland or stream.

## 5.5 Conveyance pipes

Tightline conveyance systems will be used to collect and convey trail runoff to existing trail discharge locations. The conveyance systems were sized using the Storm Sewer Design calculator spreadsheet, which uses the rational method to size the conveyance system for the 25-year design storm. Tightline

conveyance pipes were designed to be minimum 12-inch diameter. The conveyance calculations demonstrate that the 6-inch and 8-inch underdrain pipes and 12-inch storm drain pipes all have capacity to convey the 25-year design storm event.

The conveyance systems are described below and are shown on the plans provided in Appendix C4.

#### TDA 12 – Sta. 298+90 (Driveway #2)

The existing conveyance system consists of a type 1 catch basin located in the northeast corner of the trail and driveway intersection near Sta. 298+90. The purpose of this catch basin is to collect runoff from the private property access driveway from East Lake Sammamish Parkway to the trail crossing, and from the east ditch of the trail south of this intersection. Trail improvements in this location will place the existing catch basin in the middle of the trail. Therefore, the proposed design will install a new catch basin type 1 in the new northeast corner of the trail and driveway intersection. The new catch basin will be connected to the existing catch basin with an 8-inch storm drain pipe. The amount of runoff conveyed by this system will be reduced to only be the driveway runoff. As previously described, trail runoff will be collected and conveyed south the infiltration chamber via underdrain conveyance system.

#### TDA 19 and 20 – Sta. 314+46 (Connection to private conveyance)

The underdrain system from Sta. 314+46 to Sta. 320+31 flows south and connects the new catch basin type 2 at Sta. 314+46. From this catch basin the enclosed conveyance system flows west in a new 12-inch storm drain pipe and connects to an existing catch basin type 1 located on private property west of the trail near Sta. 314+46. Conveyance calculations show that the 8-inch underdrains and 12-inch storm drains have adequate pipe capacity to convey the 25-year design storm event.

The conveyance system connection to the private drainage system will require a drainage covenant agreement with the property owner if King County Parcel 0724069123. The properties adjacent to the trail in this vicinity are currently being developed, and they have described to King County Parks that they plan to use the existing direct discharge outfall located on this site to comply with their project's flow control requirements. Therefore, King County Parks has had discussions with the land developers, and the two entities have verbal agreement that King County Parks will be allowed to contribute trail runoff to the private drainage system that directly discharges to Lake Sammamish as means of satisfying flow control requirements for the trail in this TDA.

#### **Direct Discharge**

The new outfall meets direct discharge requirements per Section 1.2.3 of the 2009 Manual (page 1-37) as follows:

- a) The proposed design connects the trail stormwater conveyance to an existing conveyance system that discharges to Lake Sammamish.
- b) The existing conveyance system discharges Lake Sammamish, is comprised of 12-inch storm drain pipe, and is located on private property
- c) Conveyance calculations (Appendix C4) demonstrate that the existing 12-inch conveyance system has enough capacity to convey approximately 8 cfs at full flow capacity. The build-out trail condition contributes approximately 0.5 cfs at the 25-year design storm, providing approximately 7.5 cfs of additional capacity in the outfall pipe.
- d) The conveyance system will be enclosed pipes and the existing outfall does not have erosion problems at the outfall to Lake Sammamish.
- e) The existing trail sheet flows west toward the lake, but trail improvements in TDA 20 require flow control. The proposed wall limits the ability for the project to use basic dispersion as a

FCBMP, and the underlying soils limit the ability to use limited infiltration as a FCBMP. Therefore, the project design proposes to convey trail runoff to this existing direct discharge pipe in TDA 19 to meet the flow control exemption for TDA 20. The conveyance calculations demonstrate that the existing conveyance system has capacity to handle the addition of trail runoff. This change in existing flow pattern will not cause significant adverse impact to wetlands or streams located in TDAs 19 and 20.

#### TDAs 20, 21 and 22 – Sta. 323+00 to Sta. 328+65

This conveyance system replaces the slow draining drainage ditches located east and west of the trail from Sta. 320+70 to Sta. 325+75. The trail will slope east where runoff will be collected in the underdrain trench located in the shoulder. The underdrains are connected to catch basins located in west trail shoulder at Sta. 322+99, Sta. 324+98, and Sta. 325+72. The proposed system flows north from Sta. 322+99 to Sta. 328+65, and consists of 12-inch diameter pipes, four type 1 catch basins located at Sta. 322+99, Sta. 324+98, Sta. 325+72, and 327+34, and one type 2 catch basin at Sta. 328+64. At Sta. 328+64, the type 2 catch basin receives the 8-inch underdrain from the north, and discharges west to Lake Sammamish via a 12-inch pipe. Conveyance calculations show that the 8-inch underdrains and 12-inch storm drains have adequate pipe capacity to convey the 25-year design storm event

The new outfall is a direct discharge to Lake Sammamish, therefore, the contributing drainage areas are exempt from flow control requirements.

#### ***Direct Discharge***

The new outfall meets direct discharge requirements per Section 1.2.3 of the 2009 Manual (page 1-37) as follows:

- a) The conveyance system discharges to Lake Sammamish.
- b) The conveyance system will extend to the ordinary high water mark (OHWM) at the embankment of the end of the prism, will be comprised of 12-inch storm drain pipe, and will be located within the project property boundary.
- c) Conveyance calculations (Appendix C4) demonstrate that the conveyance system has enough capacity to convey the build-out condition of the contributing area (trail is the only contributing area).
- d) The conveyance system will be enclosed pipes and the outfall will have quarry spalls for erosion protection at the outfall to Lake Sammamish.
- e) The direct discharge is designed to maintain and improve existing flow patterns, and will not cause significant adverse impact to a wetland or stream.

#### TDAs 30A – Sta. 361+00 to Sta. 361+60

This conveyance system improves an existing drainage system that consisted of a 6-inch diameter pipe that crossed the trail near Sta. 361+60 and connected to a small area drain structure west of the trail. This system continues west via 6-inch pipe to a catch basin located in East Lake Sammamish Shore Lane SE near Sta. 361+35, and further west on private property prior to discharging to Lake Sammamish. The proposed system consists of 12-inch diameter pipes and four type 1 catch basins. The proposed system will begin in the east trail ditch in a catch basin at Sta. 361+05, convey north to a catch basin at Sta. 361+59, cross beneath the trail to the west into a catch basin located in East Lake Sammamish Shore Lane SE near Sta. 361+59, and then flow south and connect to a replaced catch basin located in East Lake Sammamish Shore Lane SE near Sta. 361+35. From the new catch basin in East Lake Sammamish Shore Lane SE near Sta. 361+35, the conveyance system will continue via the existing 4-inch diameter drainage pipe, flow west onto private property, and directly discharges to Lake Sammamish.

Conveyance calculations were performed to confirm that the 12-inch storm drain will have capacity to convey contributing flows during the 25-year storm event. The calculations also show that the 4-inch diameter pipe that was installed by the private property owners does not have conveyance capacity to convey the 25-year design storm event. If the private property owner were to upgrade the pipe to a 12-inch diameter pipe, then the conveyance system would have adequate capacity to convey the 25-year design storm event.

#### TDA 32 – Sta. 365+75 to Sta. 367+75

To accommodate trail improvements that include a fill wall west of the trail in this vicinity, the proposed design will extend the existing 12-inch diameter culvert and connect the pipe to a new type 2 catch basin that will be located at least two feet from the base of the wall, horizontally. This design will require the existing open drainage structure, which serves as connection between the trail culvert and the East Lake Sammamish Shore Lane SE culvert, to be filled and the Shore Lane pipe will be removed and relocated to connect to the new catch basin, which will have a solid metal cover.

Conveyance calculations were performed to determine if the 12-inch diameter conveyance system would have capacity to convey runoff from the contributing off-site drainage basin (approximately 13.5 acres) from the Sammamish Plateau, which feeds Unnamed Stream #7. The calculations confirm that the proposed design of the 12-inch diameter pipe will have adequate capacity to convey the 25-year design storm through the system to the open channel located on private property between 1317 East Lake Sammamish Shore Lane SE and 1309 East Lake Sammamish Shore Lane SE.

#### TDA 54 – Sta. 434+50 to Sta. 441+10

This conveyance system improves an existing drainage system that currently causes a drainage nuisance problem at the boat launch driveway of 439 East Lake Sammamish Shore Lane NE. As described in Section 3.5, project design will replace the existing 6-inch drain pipe conveyance system located in East Lake Sammamish Shore Lane NE and on the private property with a conveyance system that consists of 12-inch diameter storm pipe and type 1 catch basins. This system will also create a new direct discharge outfall to Lake Sammamish at the end of the boat launch.

Conveyance calculations were performed to confirm that the new 12-inch storm drain will have capacity to convey contributing flows during the 25-year storm event. Using the Rational Method, the contributing areas are calculated to generate approximately 0.5 cfs. The 12-inch storm pipe at 2 percent slope has capacity to convey 5.0 cfs at full flow. Therefore, the new system has adequate capacity to convey contributing runoff to Lake Sammamish, and should alleviate the current drainage nuisance problem.

#### **Direct Discharge**

The new outfall meets direct discharge requirements per Section 1.2.3 of the 2009 Manual (page 1-37) as follows:

- a) The conveyance system discharges to Lake Sammamish.
- b) The conveyance system will extend to the ordinary high water mark (OHWM) at end of the boat launch, will be comprised of 12-inch storm drain pipe, and will be located within either a drainage easement or covenant that will be established with the property owner at 439 East Lake Sammamish Shore Lane NE.
- c) Conveyance calculations (Appendix C4) demonstrate that the conveyance system has enough capacity to convey the build-out condition of the contributing area (trail is the only contributing area).

- d) The conveyance system will be enclosed pipes and the outfall will have quarry spalls for erosion protection at the outfall to Lake Sammamish.
- e) The direct discharge is designed to maintain and improve existing flow patterns, and will not cause significant adverse impact to a wetland or stream.

#### TDA 56 – Sta. 444+30 to Sta. 448+66

The design proposes a new conveyance system consisting of 12-inch storm drain pipe and six catch basin structures that will convey runoff from Wetland 28E north, and cross beneath the trail near Sta. 448+40. The proposed system will not discharge to the open planting bed, but instead is proposed to directly discharge to Lake Sammamish via a drainage easement located along the north property boundary of 833 East Lake Sammamish Parkway NE. This system will create a new direct discharge outfall to Lake Sammamish at the northwest beach of the property at 833 East Lake Sammamish Parkway NE.

Conveyance calculations were performed to confirm that the new 12-inch storm drain will have capacity to convey contributing flows during the 25-year storm event. Using the Rational Method, the contributing areas are calculated to generate approximately 0.5 cfs. The 12-inch storm pipe at the 1 percent slope has capacity to convey 3.5 cfs at full flow. Therefore, the new system has adequate capacity to convey contributing runoff to Lake Sammamish.

#### ***Direct Discharge***

The new outfall meets direct discharge requirements per Section 1.2.3 of the 2009 Manual (page 1-37) as follows:

- a) The conveyance system discharges to Lake Sammamish.
- b) The conveyance system will extend to the ordinary high water mark (OHWM), will be comprised of 12-inch storm drain pipe, and will be located within either a drainage easement or covenant that will be established with the property owner at 833 East Lake Sammamish Parkway NE.
- c) Conveyance calculations (Appendix C4) demonstrate that the conveyance system has enough capacity to convey the build-out condition of the contributing area (trail is the only contributing area).
- d) The conveyance system will be enclosed pipes and the outfall will have quarry spalls for erosion protection at the outfall to Lake Sammamish.
- e) The direct discharge is designed to maintain and improve existing flow patterns, and will not cause significant adverse impact to a wetland or stream.

#### TDA 58 – Sta. 450+70 to Sta. 453+95

The design proposes to install a new conveyance system consisting of 18-inch storm drain pipe and two new type 1 catch basin structures east of the trail within the existing gravel parking area. There is an existing catch basin at Station 451+82 that will be located in the trail shoulder. This catch basin will remain and serve as a junction connection between the underdrain conveyance and new storm drain conveyance. The new 18-inch conveyance pipes will convey trail runoff north to the type 2 catch basin located east of the trail near Station 452+90. The proposed system will not change the existing drainage pattern, but will provide upgraded conveyance to the existing system, that contributes runoff to Unnamed Stream #11 at the connection to the existing catch basin near Station 452+90.

Conveyance calculations were performed to confirm that the new 18-inch storm drain will have capacity to convey contributing trail flows during the 25-year storm event. Using the Rational Method, the contributing areas are calculated to generate approximately 0.3 cfs. The 18-inch storm pipe at the 1 percent slope has capacity to convey 10.5 cfs at full flow. Therefore, the new system has adequate capacity to convey contributing trail runoff to the catch basin near Station 452+90 that conveys

Unnamed Stream #11 through the project site via 24-inch storm pipe. There are no existing drainage problems downstream of the existing 24-inch pipe, therefore, a quantitative pipe capacity evaluation was not performed. Qualitatively, the contributing trail runoff of 0.3 cfs at the 25 year flow rate will not overwhelm this large pipe that has full flow capacity of 61.2 cfs at the 7.33 percent slope.

#### TDA 60A – Sta. 456+30 to Sta. 458+65

The design proposes installing 12-inch storm drain pipe and type 1 and type 2 catch basins. The improvements start at the catch basin located at the east end of the gravel parking area near station 457+25, cross the trail near Station 456+30, where the existing 8-inch drain pipe is said to be located, and connect to the existing drain pipe in a new type 2 catch basin located west of the trail near Station 456+30.

Conveyance calculations were performed to confirm that the new 12-inch storm drain will have capacity to convey contributing flows during the 25-year storm event. Using the Rational Method, the contributing areas are calculated to generate approximately 0.5 cfs. The 12-inch storm pipe at 2.5 percent slope has capacity to convey 5.6 cfs at full flow. Therefore, the new system has adequate capacity to convey contributing runoff to Lake Sammamish.

## 6. SPECIAL REPORTS AND STUDIES

Special reports and studies have been completed for this project including the following:

- Draft Geotechnical Engineering Report (Icicle Creek Engineers, Inc. 2016)

A geotechnical analysis was performed to evaluate the suitability of the site soils for construction of walls and wall foundations, and construction of infiltration trenches along the trail corridor.

- Draft Critical Areas Study (Parametrix 2016)

The critical areas study evaluated the proposed trail impacts on the many wetlands, wetland buffers, streams, and stream buffers along the trail corridor in Sammamish. Because of the amount of wetland buffer impacts created by the new trail alignment, there will be onsite wetland buffer mitigation. The critical areas report explains the impacts study and describes the selection and sizes of the onsite mitigation locations.

DRAFT





## 7. OTHER PERMITS

Other permits required for this project are listed below.

- City of Sammamish Substantial Shoreline Development Permit
- City of Sammamish Grading Permit
- City of Sammamish ROW Use Permit
- Section 404 Permit by the U.S. Army Corps of Engineers
- Hydraulic Project Approval
- National Pollutant Discharge Elimination System (NPDES) General Construction Permit
- Washington State Department of Ecology, Coastal Zone Management concurrence
- Section 401 Water Quality Certification

DRAFT



## 8. TESC DESIGN

The temporary erosion and sediment control design is not complete at this time, but will be completed and submitted with the Final TIR as part of the grading permit documents.

DRAFT



## 9. BOND QUANTITIES, FACILITY SUMMARIES, AND DECLARATION OF COVENANT

The project does not require Bond Quantities. The plans provide the facility summaries. Drainage easements and covenants may be necessary for the proposed drainage design as in particular areas of the project. The project team will secure drainage easements and covenants with property owners before construction begins.

DRAFT



## 10. OPERATION AND MAINTENANCE

### 10.1 Stormwater Management

The stormwater system in South Sammamish Segment B consists of ditches, culverts, storm drains, quarry spill outfall protection, catch basins, basic dispersion areas, an infiltration chamber, infiltration trenches, and underdrain trenches. Excerpts from Appendix A of the 2009 Manual describe the maintenance requirements for the following project components; these excerpts are provided in Appendix E.

- Infiltration Facilities
- Catch Basins and Manholes
- Conveyance Pipes and Ditches
- Debris Barriers
- Energy Dissipaters

#### Infiltration Trenches

Infiltration trenches are designed to infiltrate runoff from the trail up to the 100-year storm event. The trenches are designed to drain within 2 days following a storm event. Monitoring wells are not necessary and will not be provided to monitor the depth of water in the trenches. Also, the top 6 to 12 inches of crushed rock will be monitored for sediment buildup. The project design requires that the trenches be wrapped with geotextile fabric, which should keep the drain rock inside the trenches clean, so that only the top crushed rock would need to be replaced.

#### Underdrain Trenches

The underdrain trenches are designed to convey runoff from the trail to catch basins or ditches. The perforated pipes are designed to collect and convey water and the gravel trenches will collect the runoff from the trail and store it until it is absorbed into the pipe. Cleanouts will be conducted to monitor the depth of the water in the trenches. The top 6 to 12 inches of crushed rock will be monitored for sediment buildup. These trenches will also be wrapped with geotextile fabric.

### 10.2 Vegetation Management

King County Parks Department uses a Vegetation Management Plan prepared for the East Lake Sammamish Interim Use Trail. Chapter 5 of that plan describes maintenance activities for drainage, including dry and wet ditches, clearing of clogged culverts, and repair of ditches and culverts. The plan also specifies monitoring of ditches and culverts at least twice a year, including once in the fall before the rainy season.

King County's contact person for maintenance issues is Robert Nunnenkamp. His contact information is:

Email: [Robert.Nunnenkamp@kingcounty.gov](mailto:Robert.Nunnenkamp@kingcounty.gov)

Telephone: 206-291-7301





## 11. REFERENCES

- Barnard, R. J., J. Johnson, P. Brooks, K. M. Bates, B. Heiner, J. P. Klavas, D.C. Ponder, P.D. Smith, and P. D. Powers (2013), Water Crossings Design Guidelines, Washington Department of Fish and Wildlife, Olympia, Washington. Available at: <http://wdfw.wa.gov/publications/01501/>.
- City of Sammamish. 2011. City of Sammamish Surface Water Design Manual Addendum. Sammamish, WA. Available at: <http://www.sammamish.us/departments/publicworks/StormwaterManagement.aspx?Show=Engineers>.
- Icicle Creek Engineers, Inc. 2016. Draft Report, Geotechnical Engineering Services, South Sammamish Segment B, East Lake Sammamish Trail, Sammamish, Washington. Prepared by Icicle Creek Engineers, Inc. October 2016.
- King County. 2009. King County Surface Water Design Manual. Prepared by King County Department of Natural Resources and Parks, Seattle, WA.
- Parametrix. 2016. Critical Areas Study, East Lake Sammamish Master Plan Trail – South Sammamish Segment B. Prepared by Parametrix, Seattle, WA. October 2016.



DRAFT

## Appendix A

Drainage Plans, Profiles, and Detail Sheets



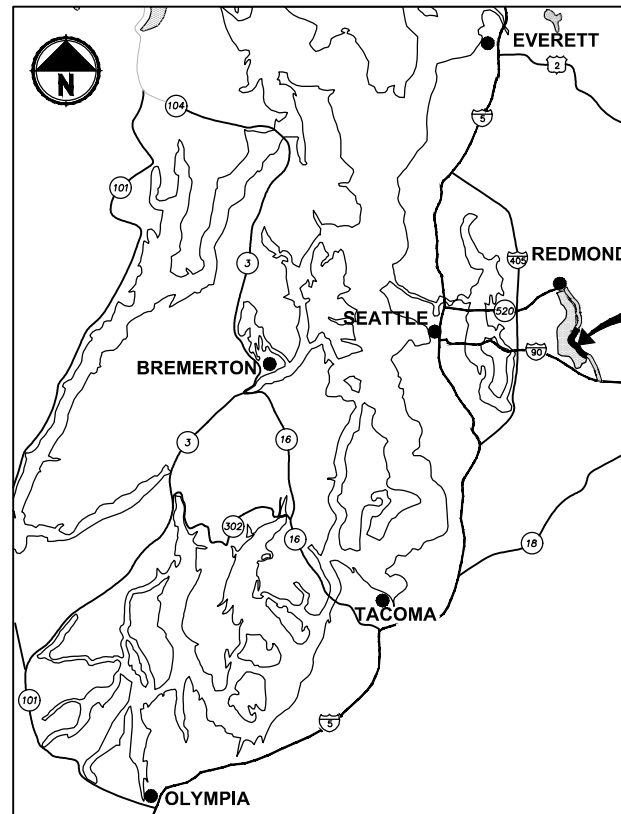


# East Lake Sammamish Master Plan Trail, South Sammamish Segment B

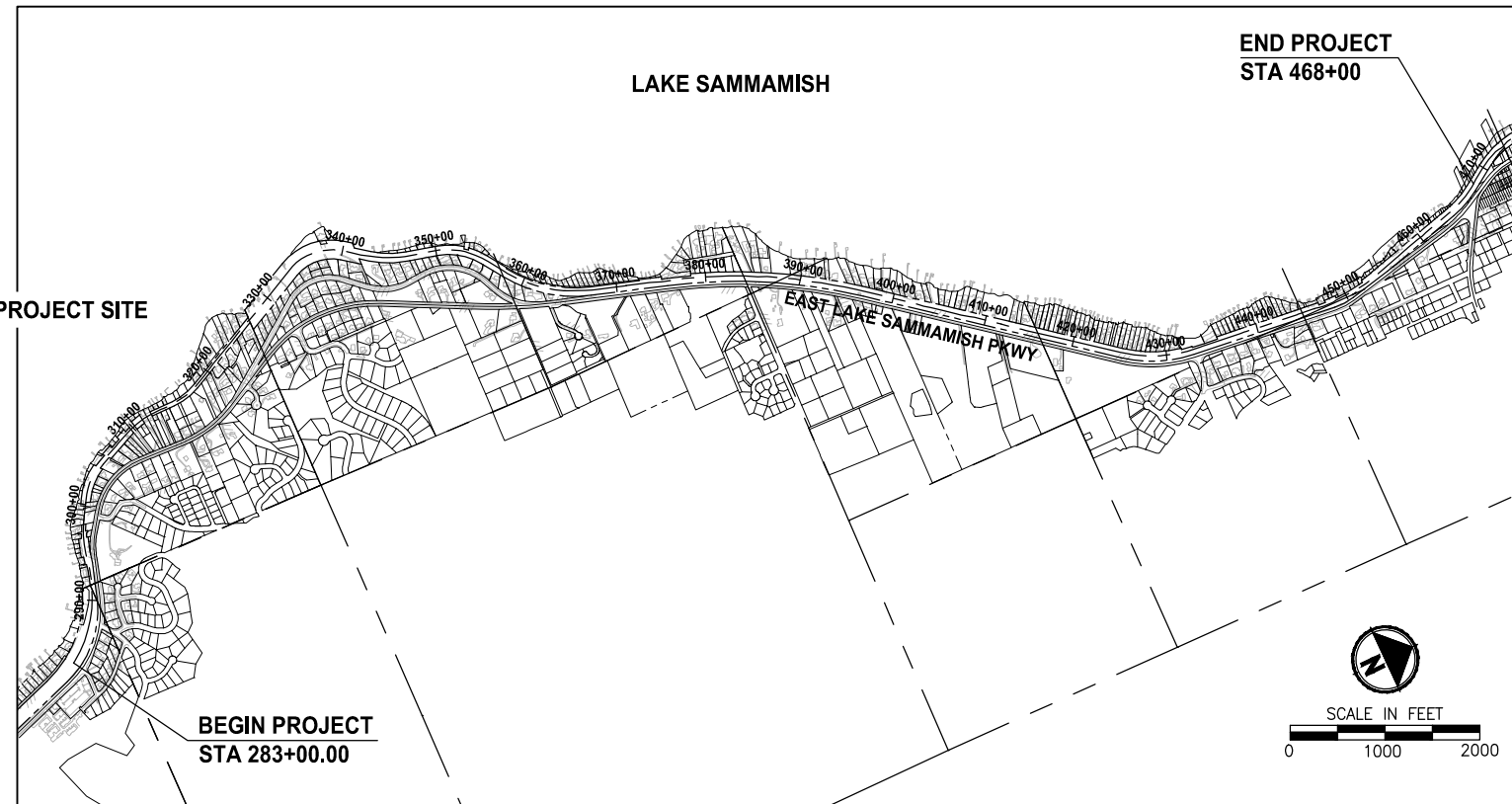
## SE 33rd Street to Inglewood Hill Road

### King County, Washington

## CONTRACT NO. XX



**LOCATION MAP**  
NOT TO SCALE



**VICINITY MAP**

**RIGHT OF WAY NOTE:**

RIGHT OF WAY LINES SHOWN ARE BASED ON KING COUNTY MAP VAULT SURVEY OF EAST LAKE SAMMAMISH TRAIL, MAP NUMBER 311-99, DATED AUGUST 8TH, 1998, WITH SUBSEQUENT CONVEYANCES AND EASEMENTS BEING UPDATED ACCORDING TO AUDITOR DOCUMENTS OF RECORD.

**PROPERTY INFORMATION:**

PARCEL NUMBERS:	ACRES
2925069007	(11.13 ACRES)
082406-9214	(9.16 ACRES)
072406-9119	(0.08 ACRE)
072406-9039	(0.22 ACRE)
072406-9040	(0.12 ACRE)
072406-9036	(0.27 ACRE)
406510-0005	(0.48 ACRE)
406510-0011	(0.10 ACRE)
072406-9033	(0.27 ACRE)
322506-9015	(13.79 ACRES)
062406-9013	(15.19 ACRES)
072406-9004	(2.16 ACRES)

**PROJECT & SITE INFORMATION:**

KING COUNTY PROPOSES TO DEVELOP AN ALTERNATIVE TRANSPORTATION CORRIDOR AND RECREATION TRAIL ALONG 3.5 MILES OF A FORMER RAILROAD CORRIDOR IN THE CITY OF SAMMAMISH, LOCATED BETWEEN ISSAQUAH/SAMMAMISH CITY LIMIT AND INGLEWOOD HILL ROAD. A GRAVEL INTERIM TRAIL IS CURRENTLY IN OPERATION.

DISTURBED AREA = 9.5 AC  
 EXISTING IMPERVIOUS AREA = 5.3 AC  
 PROPOSED IMPERVIOUS AREA = 8.4 AC  
 VOLUME OF ESTIMATED FILL = 4,300 CY  
 VOLUME OF ESTIMATED EXCAVATION = 7,000 CY

**WRITTEN DESCRIPTION OF THE PROJECT:**

THE EXISTING GRAVEL TRAIL WILL BE WIDENED TO 12 FEET AND PAVED WITH 2-FOOT GRAVEL SHOULDERS ON BOTH SIDES.

THE PROPOSED IMPROVEMENTS INCLUDE RETAINING WALLS, DRAINAGE IMPROVEMENTS, FENCE, SIGNS AND MITIGATION FOR IMPACTS TO WETLANDS AND WETLAND AND STREAM BUFFERS.

**EXISTING ZONE CLASSIFICATION:**

COMMUNITY FACILITIES CF-F

**EXISTING SHORELINE ENVIRONMENT DESIGNATION:**

CITY OF SAMMAMISH DESIGNATION: SHORELINE RESIDENTIAL

**GENERAL PURPOSE OF THIS PROJECT:**

TO DEVELOP AN ALTERNATIVE TRANSPORTATION CORRIDOR IN A FORMER RAILROAD CORRIDOR.

**CONTACT INFORMATION:**

APPLICANT:  
 KING COUNTY PARKS AND RECREATION DIVISION  
 201 S. JACKSON, 7TH FLR  
 SEATTLE, WA 98104  
 (206) 263-7283  
 CONTACT: GINA AULD

SURVEYOR:  
 PARAMETRIX  
 719 2ND AVENUE  
 SUITE 200  
 SEATTLE, WA 98104  
 (206) 394-3700  
 CONTACT: DANIEL THIBODEAU

OWNER:  
 KING COUNTY PARKS AND RECREATION DIVISION

ARBORIST:  
 AMERICAN FOREST MANAGEMENT, INC  
 11415 NE 128TH ST SUITE 110  
 KIRKLAND, WA 98034  
 (425) 820-3420  
 CONTACT: BOB LAYTON

ENGINEER:  
 PARAMETRIX  
 719 2ND AVENUE  
 SUITE 200  
 SEATTLE, WA 98104  
 (206) 394-3700  
 CONTACT: YAMMIE HO, P.E.

UTILITY:  
 ONE-CALL 1 (800) 424-5555

SAMMAMISH PLATEAU WATER AND SEWER DISTRICT  
 (425) 392-6256 EXT. 223  
 CONTACT: KEVIN ROUEN

NORTHEAST SAMMAMISH SEWER AND WATER DISTRICT  
 (425) 868-1144  
 CONTACT: ART PRIMEAU

COMCAST CABLE  
 (425) 867-7433  
 CONTACT: DAVID RURROWS

FRONTIER COMMUNICATIONS NW INC.  
 HOTLINE 1 (800) 921-8101

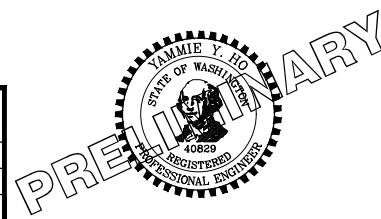
PUGET SOUND ENERGY  
 (POWER AND GAS)  
 (425) 462-3727  
 CONTACT: REBECCA NICHOLAS

CITY OF SAMMAMISH APPROVAL	
City Engineer	Date
Community Development	Date

**60 % REVIEW SUBMITTAL**  
 NOT FOR CONSTRUCTION

REVISIONS	DATE	BY	DESIGNED
			M. TSUN
			B. PURGANAN
			P. JOHANNESSEN
			Y. HO

**ONE INCH AT FULL SCALE, IF NOT, SCALE ACCORDINGLY**  
 FILE NAME: BL1521075P19T03G-01  
 JOB No: 554-1521-075 P19 T03  
 DATE: SEPTEMBER 2016



**Parametrix**  
 ENGINEERING · PLANNING · ENVIRONMENTAL SCIENCES  
 719 2ND AVENUE, SUITE 200 | SEATTLE, WA 98104  
 P 206.394.3700  
 WWW.PARAMETRIX.COM

PROJECT NAME  
**EAST LAKE SAMMAMISH MASTER PLAN TRAIL SOUTH SAMMAMISH SEGMENT B**  
 SAMMAMISH, WA

**COVER SHEET**

SHEET NO.  
 1 OF 135  
**G1**

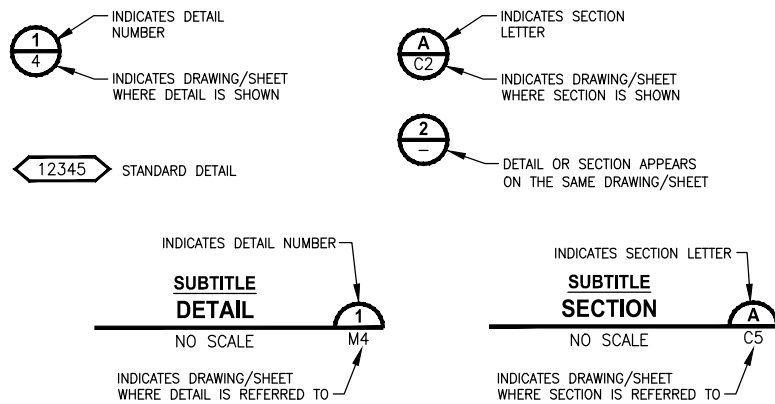
LAYOUT: G1  
 PATH: U:\PSP\Projects\Clients\1521-075-ELST\998\Draw\19\T03\_Civil\Draw\ PLOTTED BY: purgabut DATE: Wednesday, October 12, 2016 8:20:48 PM

LAYOUT: 02      PATH: U:\PSO\Projects\Clients\1521-075-ELST\995\cadd\Phase 19 T03 Civil\Drawg\      PLOTTED BY: purgabut      DATE: Wednesday, October 12, 2016 8:21:23 PM

**ABBREVIATIONS:**

ACP	ASPHALT CONCRETE PAVEMENT	N	NORTH, NORTHING
BOC	BACK OF CURB	N.I.C.	NOT IN CONTRACT
BOW	BOTTOM OF WALL	NST	NOT STEEPER THAN
BVCE	BEGIN VERTICAL CURVE ELEVATION	PC	POINT OF CURVE
BVCS	BEGIN VERTICAL CURVE STATION	PT	POINT OF TANGENT
CB	CATCH BASIN	P/L	PROPERTY LINE
C&G	CURB AND GUTTER	PUD	PUBLIC UTILITY DISTRICT
C/L	CENTERLINE	PVI	POINT OF VERTICAL INTERSECTION
CONC	CONCRETE	REINF	REINFORCED
CONST	CONSTRUCTION	ROW or R/W	RIGHT-OF-WAY
CMP	CORRUGATED METAL PIPE	SD	STORM DRAIN
CP	CONCRETE PIPE	SDMH	STORMWATER MANHOLE
CSTC	CRUSHED SURFACING TOP COURSE	SIM	SIMILAR
DIA	DIAMETER	SS	SANITARY SEWER
DI, DIP	DUCTILE IRON PIPE	ST	STEEL
E	EAST, EASTING	STA	STATION
EOA	EDGE OF ASPHALT	TEL	TELEPHONE
EVCE	END VERTICAL CURB ELEVATION	TESC	TEMPORARY EROSION AND SEDIMENT CONTROL
EVCS	END VERTICAL CURB STATION	TOW	TOP OF WALL
EOG	EDGE OF GRAVEL	TYP	TYPICAL
EOP	EDGE OF PAVEMENT	W	WATER
EX, EXIST	EXISTING	WS	WATER SERVICE
FOC	FACE OF CURB	WSDOT	WASHINGTON STATE DEPARTMENT OF TRANSPORTATION
FL	FLANGE, FLOWLINE	WWM	WELDED WIRE MESH
G	GAS		
GB	GRADE BREAK		
HMA	HOT MIX ASPHALT		
IE	INVERT ELEVATION		
LF	LINEAR FEET		
LP	LOW POINT		
LT	LEFT		
ME	MATCH EXISTING		
MIN	MINIMUM		
MON	MONUMENT		

**DETAIL AND SECTION DESIGNATION**



INDEX TO DRAWINGS		
DWG NO.	SHT NO.	SHEET TITLE
<b>GENERAL</b>		
1	G1	COVER SHEET
2	G2	ABBREVIATIONS AND SHEET LIST
3	G3	SHEET INDEX
4	G4	LEGEND
5	G5	SURVEY CONTROL PLAN
6	G6	SURVEY CONTROL PLAN
7	G7	SURVEY CONTROL PLAN
8	G8	SURVEY CONTROL PLAN
<b>EXISTING CONDITIONS</b>		
9	EX1	EXISTING CONDITIONS PLAN
10	EX2	EXISTING CONDITIONS PLAN
11	EX3	EXISTING CONDITIONS PLAN
12	EX4	EXISTING CONDITIONS PLAN
13	EX5	EXISTING CONDITIONS PLAN
14	EX6	EXISTING CONDITIONS PLAN
15	EX7	EXISTING CONDITIONS PLAN
16	EX8	EXISTING CONDITIONS PLAN
17	EX9	EXISTING CONDITIONS PLAN
18	EX10	EXISTING CONDITIONS PLAN
19	EX11	EXISTING CONDITIONS PLAN
20	EX12	EXISTING CONDITIONS PLAN
21	EX13	EXISTING CONDITIONS PLAN
22	EX14	EXISTING CONDITIONS PLAN
23	EX15	EXISTING CONDITIONS PLAN
24	EX16	EXISTING CONDITIONS PLAN
25	EX17	EXISTING CONDITIONS PLAN
26	EX18	EXISTING CONDITIONS PLAN
27	EX19	EXISTING CONDITIONS PLAN
28	EX20	EXISTING CONDITIONS PLAN
29	EX21	EXISTING CONDITIONS PLAN
<b>TYPICAL CROSS SECTIONS</b>		
30	CS1	TYPICAL CROSS SECTIONS
31	CS2	TYPICAL CROSS SECTIONS
32	CS3	TYPICAL CROSS SECTIONS
<b>TRAIL PLAN &amp; PROFILE</b>		
33	AL1	PLAN AND PROFILE
34	AL2	PLAN AND PROFILE
35	AL3	PLAN AND PROFILE
36	AL4	PLAN AND PROFILE
37	AL5	PLAN AND PROFILE
38	AL6	PLAN AND PROFILE
39	AL7	PLAN AND PROFILE
40	AL8	PLAN AND PROFILE
41	AL9	PLAN AND PROFILE
42	AL10	PLAN AND PROFILE
43	AL11	PLAN AND PROFILE
44	AL12	PLAN AND PROFILE
45	AL13	PLAN AND PROFILE
46	AL14	PLAN AND PROFILE
47	AL15	PLAN AND PROFILE
48	AL16	PLAN AND PROFILE
49	AL17	PLAN AND PROFILE
50	AL18	PLAN AND PROFILE
51	AL19	PLAN AND PROFILE
52	AL20	PLAN AND PROFILE
53	AL21	PLAN AND PROFILE
54	AL22	PLAN AND PROFILE
55	AL23	PLAN AND PROFILE
56	AL24	PLAN AND PROFILE
57	AL25	PLAN AND PROFILE
58	AL26	PLAN AND PROFILE
59	AL27	PLAN AND PROFILE
60	AL28	PLAN AND PROFILE
61	AL29	PLAN AND PROFILE
62	AL30	PLAN AND PROFILE
63	AL31	PLAN AND PROFILE
64	AL32	PLAN AND PROFILE
65	AL33	PLAN AND PROFILE
66	AL34	PLAN AND PROFILE
67	AL35	PLAN AND PROFILE
68	AL36	PLAN AND PROFILE
69	AL37	PLAN AND PROFILE
70	AL38	PLAN AND PROFILE
71	AL39	PLAN AND PROFILE
<b>STORM DRAIN PROFILES</b>		
72	SD1	STORM DRAIN PROFILES AND SECTIONS
73	SD2	STORM DRAIN PROFILES AND SECTIONS
74	SD3	STORM DRAIN PROFILES AND SECTIONS
<b>DRAINAGE DETAILS</b>		
75	DD1	DRAINAGE DETAILS
76	DD2	DRAINAGE DETAILS

INDEX TO DRAWINGS (CONTINUED)		
DWG NO.	SHT NO.	SHEET TITLE
<b>FISH PASSAGE CULVERTS</b>		
77	FP1	FISH PASSAGE CULVERTS
78	FP2	FISH PASSAGE CULVERTS
79	FP3	FISH PASSAGE CULVERTS
80	FP4	FISH PASSAGE CULVERTS
81	FP5	FISH PASSAGE CULVERTS
82	FP6	FISH PASSAGE CULVERTS
83	FP7	FISH PASSAGE CULVERTS
84	FP8	FISH PASSAGE CULVERTS
<b>DRIVEWAY PLAN AND PROFILE</b>		
85	DP1	DRIVEWAY PLAN AND PROFILE
86	DP2	DRIVEWAY PLAN AND PROFILE
87	DP3	DRIVEWAY PLAN AND PROFILE
88	DP4	DRIVEWAY PLAN AND PROFILE
89	DP5	DRIVEWAY PLAN AND PROFILE
90	DP6	DRIVEWAY PLAN AND PROFILE
91	DP7	DRIVEWAY PLAN AND PROFILE
92	DP8	DRIVEWAY PLAN AND PROFILE
93	DP9	DRIVEWAY PLAN AND PROFILE
94	DP10	DRIVEWAY PLAN AND PROFILE
95	DP11	DRIVEWAY PLAN AND PROFILE
96	DP12	DRIVEWAY PLAN AND PROFILE
<b>WALL PROFILES</b>		
97	WP1	WALL PROFILES
98	WP2	WALL PROFILES
99	WP3	WALL PROFILES
100	WP4	WALL PROFILES
101	WP5	WALL PROFILES
102	WP6	WALL PROFILES
103	WP7	WALL PROFILES
104	WP8	WALL PROFILES
105	WP9	WALL PROFILES
<b>STRUCTURE</b>		
106	S1	WALL #3 SOLDIER PILE WALL
107	S2	WALL #3 SOLDIER PILE WALL
108	S3	WALL #6 SOLDIER PILE WALL
109	S4	WALL #6 SOLDIER PILE WALL
110	S5	SOLDIER PILE WALL DETAILS
111	S6	SOLDIER PILE WALL DETAILS
<b>MISCELLANEOUS DETAILS</b>		
112	MD1	MISCELLANEOUS DETAILS
<b>MITIGATION</b>		
113	LA1	LANDSCAPE PLAN
114	LA2	LANDSCAPE PLAN
115	LA3	LANDSCAPE PLAN
116	LA4	LANDSCAPE PLAN
117	LA5	LANDSCAPE PLAN
118	LA6	LANDSCAPE PLAN
119	LA7	LANDSCAPE PLAN
120	LA8	LANDSCAPE PLAN
121	LA9	LANDSCAPE PLAN
122	LA10	LANDSCAPE PLAN
123	LA11	LANDSCAPE PLAN
124	LA12	LANDSCAPE PLAN
125	LA13	LANDSCAPE PLAN
126	LA14	LANDSCAPE PLAN
127	LA15	LANDSCAPE PLAN
128	LA16	LANDSCAPE PLAN
129	LA17	LANDSCAPE PLAN
130	LA18	LANDSCAPE PLAN
131	LA19	LANDSCAPE PLAN
132	LA20	LANDSCAPE PLAN
133	LA21	LANDSCAPE PLAN
134	LA22	MITIGATION PLANTING DETAILS
135	LA23	MITIGATION NOTES

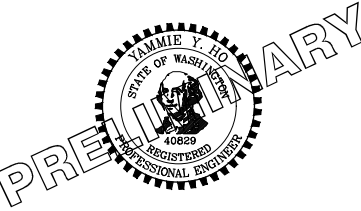
CITY OF SAMMAMISH APPROVAL	
City Engineer _____	Date _____
Community Development _____	Date _____

**60 % REVIEW SUBMITTAL  
NOT FOR CONSTRUCTION**

REVISIONS	DATE	BY	DESIGNED
			M. TSUN
			B. PURGANAN
			P. JOHANNESSEN
			Y. HO

**ONE INCH AT FULL SCALE, IF NOT, SCALE ACCORDINGLY**

FILE NAME: BL1521075P19T03G-02  
 JOB No.: 554-1521-075 P19 T03  
 DATE: SEPTEMBER 2016



**Parametrix**  
 ENGINEERING · PLANNING · ENVIRONMENTAL SCIENCES

719 2ND AVENUE, SUITE 200 | SEATTLE, WA 98104  
 P 206.394.3700  
 WWW.PARAMETRIX.COM

PROJECT NAME  
**EAST LAKE SAMMAMISH  
 MASTER PLAN TRAIL  
 SOUTH SAMMAMISH SEGMENT B**  
 SAMMAMISH, WA

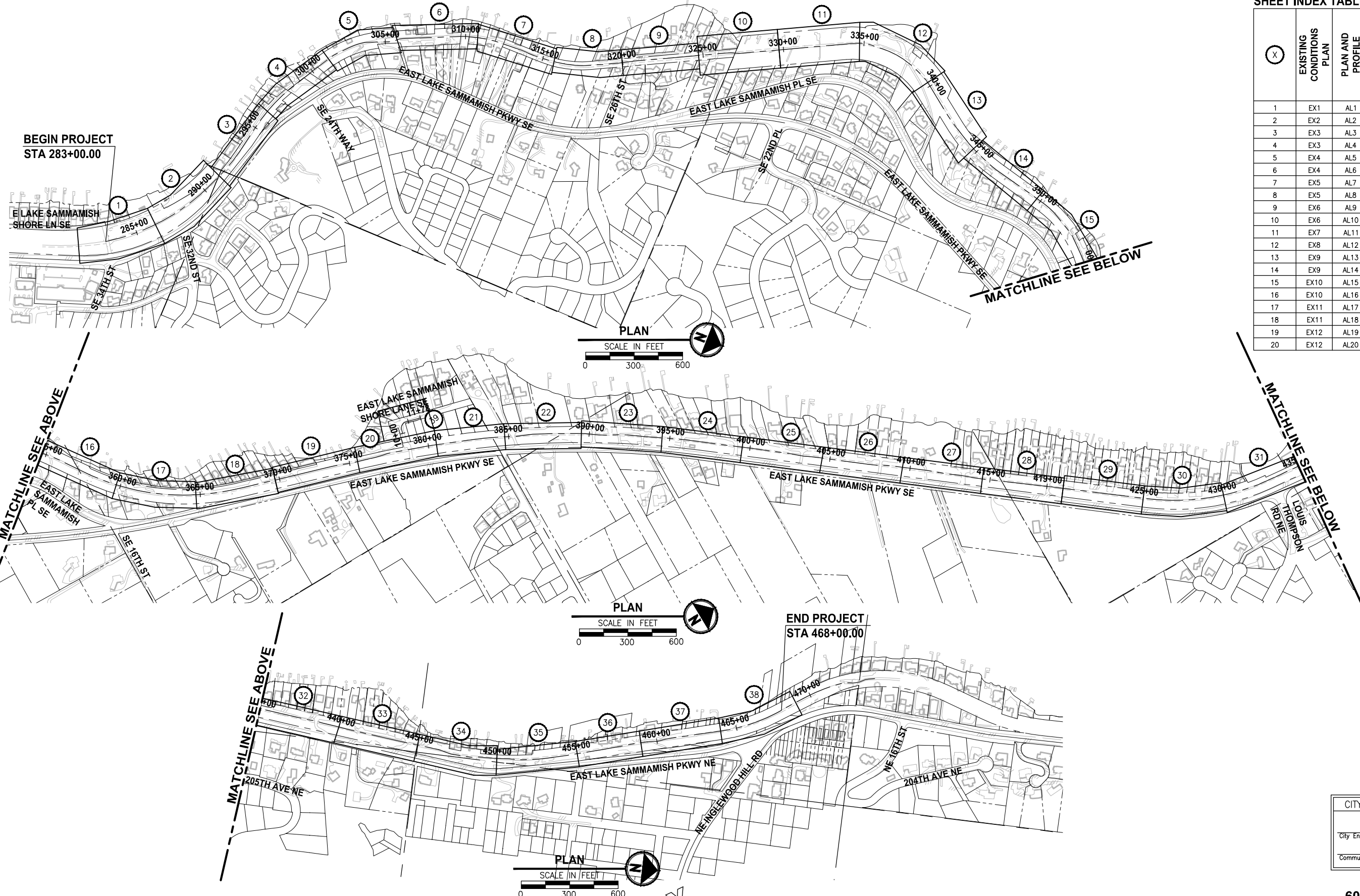
**ABBREVIATIONS AND SHEET LIST**

SHEET NO.  
2 OF 135

**G2**

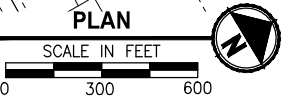
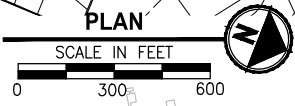


LAYOUT: G3  
 PATH: U:\PSO\Projects\Clients\1521-075-ELST\995\CA\ADD\Phase 19\T03\_Civil\Draws\ PLOTTED BY: purgaban DATE: Wednesday, October 12, 2016 8:22:49 PM



**SHEET INDEX TABLE**

(X)	EXISTING CONDITIONS PLAN	PLAN AND PROFILE	(X)	EXISTING CONDITIONS PLAN	PLAN AND PROFILE
1	EX1	AL1	21	EX13	AL21
2	EX2	AL2	22	EX13	AL22
3	EX3	AL3	23	EX14	AL23
4	EX3	AL4	24	EX14	AL24
5	EX4	AL5	25	EX15	AL25
6	EX4	AL6	26	EX15	AL26
7	EX5	AL7	27	EX16	AL27
8	EX5	AL8	28	EX16	AL28
9	EX6	AL9	29	EX17	AL29
10	EX6	AL10	30	EX17	AL30
11	EX7	AL11	31	EX18	AL31
12	EX8	AL12	32	EX18	AL32
13	EX9	AL13	33	EX19	AL33
14	EX9	AL14	34	EX19	AL34
15	EX10	AL15	35	EX20	AL35
16	EX10	AL16	36	EX20	AL36
17	EX11	AL17	37	EX21	AL37
18	EX11	AL18	38	EX21	AL38
19	EX12	AL19			
20	EX12	AL20			



CITY OF SAMMAMISH APPROVAL

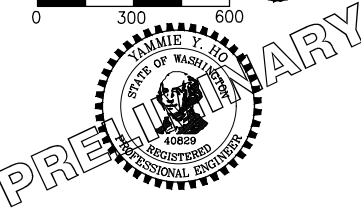
City Engineer _____	Date _____
Community Development _____	Date _____

**60 % REVIEW SUBMITTAL  
NOT FOR CONSTRUCTION**

REVISIONS	DATE	BY	DESIGNED
			M. TSUN
			B. PURGANAN
			P. JOHANNESSEN
			Y. HO

**ONE INCH AT FULL SCALE,  
IF NOT, SCALE ACCORDINGLY**

FILE NAME  
BL1521075P19T03G-03  
JOB No.  
54-1521-075 P19 T03  
DATE  
SEPTEMBER 2016



**Parametrix**  
ENGINEERING · PLANNING · ENVIRONMENTAL SCIENCES

719 2ND AVENUE, SUITE 200 | SEATTLE, WA 98104  
P 206.394.3700  
WWW.PARAMETRIX.COM

PROJECT NAME  
**EAST LAKE SAMMAMISH  
MASTER PLAN TRAIL  
SOUTH SAMMAMISH SEGMENT B**  
SAMMAMISH, WA

**SHEET INDEX**

SHEET NO.  
3 OF 135  
**G3**



LAYOUT: G4 PATH: U:\PSO\Projects\Clients\1521-1521-075-ELST\995\CA00\Phase 19 T03 Civil\Draws\ PLOTTED BY: purgaban DATE: Wednesday, October 12, 2016 8:23:23 PM

**LEGEND**

DESCRIPTION	PROPOSED	EXISTING
RIGHT OF WAY	—	R/W —
PROPERTY LINE	—	P/L - - - -
FOUND MONUMENTS		⊕ ⊗
REBAR & CAP		○
HUB & TACK		□
PK NAIL		×
FOUND MAG NAIL		+
SET MAG NAIL		+
PROPERTY CORNER		●
STREAM BUFFER	—	—
STREAM	→	→
EDGE OF WATER	—	—
WETLAND FLAG		↑
WETLAND BUFFER	—	—
ORDINARY HIGH WATER MARK	—	—
FLOODWAY BOUNDARY	—	—
DITCH	→	→
JURISDICTIONAL DITCH CENTERLINE & EDGES	→	→
UNDERDRAIN PIPE	—UD—	—
TEMPORARY DRAIN PIPE	—D—	—
STORM DRAIN	—	—SD—
CULVERT/STORM DRAIN PIPE	▬	▬
QUARRY SPALL	⊗	
INFILTRATION TRENCH	▬	
CATCH BASIN, TYPE 1	■	■
CATCH BASIN, TYPE 2	■	■
CATCH BASIN W/ SOLID LID	■	■
INLET PROTECTION	⊗	
SANITARY SEWER LINE	—	—SS—
SANITARY SEWER MANHOLE	⊙	⊙
SANITARY SEWER VAULT	⊙	⊙
CLEANOUT	●	⊙
CONTOURS MAJOR	—10—	—10—
CONTOURS MINOR	—2—	—2—
HIGH VISIBILITY SILT FENCE	—X—	
HIGH VISIBILITY FENCE	—X—	
CLEARING AND GRUBBING LIMITS	—CG—	
CLEARING LIMITS	—CLR—	
FILL LINE	—F—	
CUT LINE	—C—	
SAWCUT	▨	
ASPHALT EDGE	▬	▬
CONCRETE LINE	▬	▬
CURB AND GUTTER	▬	▬
EDGE OF PATCH	▬	▬
EDGE OF GRAVEL	▬	▬

**LEGEND**

DESCRIPTION	PROPOSED	EXISTING
BARB WIRE FENCE	—X—	—X—
SPLIT RAIL FENCE	—//—	—//—
BOARD FENCE	—□—	—□—
CHAIN LINK FENCE	—○—	—○—
TEMPORARY SAFETY FENCE	—♯—	
HOG WIRE FENCE	—○—	—○—
WOOD GUARDRAIL	—□—	—□—
GUY ANCHOR	→	→
POWER POLE WITH LIGHT	⊙	⊙
FLOOD LIGHT	⊙	⊙
UTILITY POLE	⊙	⊙
PP W/ UG DROP	⊙	⊙
PP W/ UG DROP & XMFR	⊙	⊙
OVERHEAD POWER	—	—OP—
POWER	—	—P—
POWER VAULT		▭
POWER TRANSFORMER		▭
POWER MANHOLE		⊙
POWER HANDHOLE		⊙
POWER CABINET		▭ PWR CAB
POWER RISER		▭ PR
POWER METER		▭
SOLID LID J-BOX		▭
LUMINAIRE	⊙	⊙
TELEPHONE VAULT		▭ T
TELEPHONE RISER		▭ TR
TELEPHONE MANHOLE		⊙ T
TELEPHONE		—T—
TV RISER		▭
TV		—TV—
GAS VALVE		⊙
GAS METER		⊙
GAS		—G—
WATER LINE		—W—
FIRE HYDRANT		⊙
WATER METER		⊙
WATER VALVE		⊙
AREA DRAIN		⊙
ROOF DRAIN		⊙
WATER BLOW OFF VALVE		⊙
WATER POST INDICATOR		⊙
SPRINKLER HEAD ROT=90		⊙
IRRIGATION CONTROL VALVE		⊙
FLOW DIRECTION	→	→

**LEGEND**

DESCRIPTION	PROPOSED	EXISTING
TRAFFIC SIGNAL POLE W/ LAMP		⊙
TRAFFIC SIGNAL POLE		⊙
TRAFFIC CONTROL LOOP (SQ)		▭ TL
TRAFFIC CONTROL CABINET		▭
PEDESTRIAN POLE		⊙
MONITORING WELL		⊙
SURFACE POST		⊙
SIGN	▭	▭
SKIP LANE LINE	—	—
SOLID LANE LINE	—	—
FOG LINE	—	—
LTO ARROW		↘
STO ARROW		←
RTO ARROW		↗
MAILBOX	▭	▭
DECIDUOUS TREE		⊙
CONIFEROUS TREE		⊙
WETLAND SYMBOL		⊙
WETLAND BOUNDARY		▬
VEGETATION		▬
STRUCTURAL EARTH WALL	▬	▬
SOLDIER PILE WALL	▬	▬
RIP RAP		▬
ROCKERY	▬	▬
HANDICAPPED SYMBOL		⊙
WHEELCHAIR RAMP		▬
BUILDING LINE		▬
CONCRETE STAIR LINE		▬
WOOD STAIRWAY		▬
REMOVE ASPHALT	▬	
PATTERNED CONCRETE INTERSECTION	▬	
RAMP DETECTABLE WARNING	▬	
RESTORATION PLANTING AREA	▬	
SANDBAG DAM	▬	
CHECK DAM	▬	
WATTLE CHECK DAM	▬	
FORMER RAILROAD CENTERLINE	—220+ RR C/L—	
CONSTRUCTION CENTERLINE	—220+00 A-LINE—	

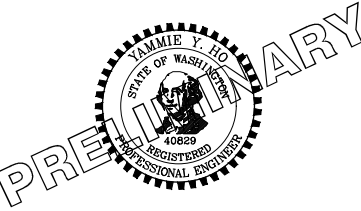
CITY OF SAMMAMISH APPROVAL	
City Engineer _____	Date _____
Community Development _____	Date _____

**60 % REVIEW SUBMITTAL  
NOT FOR CONSTRUCTION**

REVISIONS	DATE	BY	DESIGNED
			M. TSUN
			B. PURGANAN
			P. JOHANNESSEN
			Y. HO

**ONE INCH AT FULL SCALE,  
IF NOT, SCALE ACCORDINGLY**

FILE NAME: BL1521075P19T03G-04  
JOB No: 554-1521-075 P19 T03  
DATE: SEPTEMBER 2016



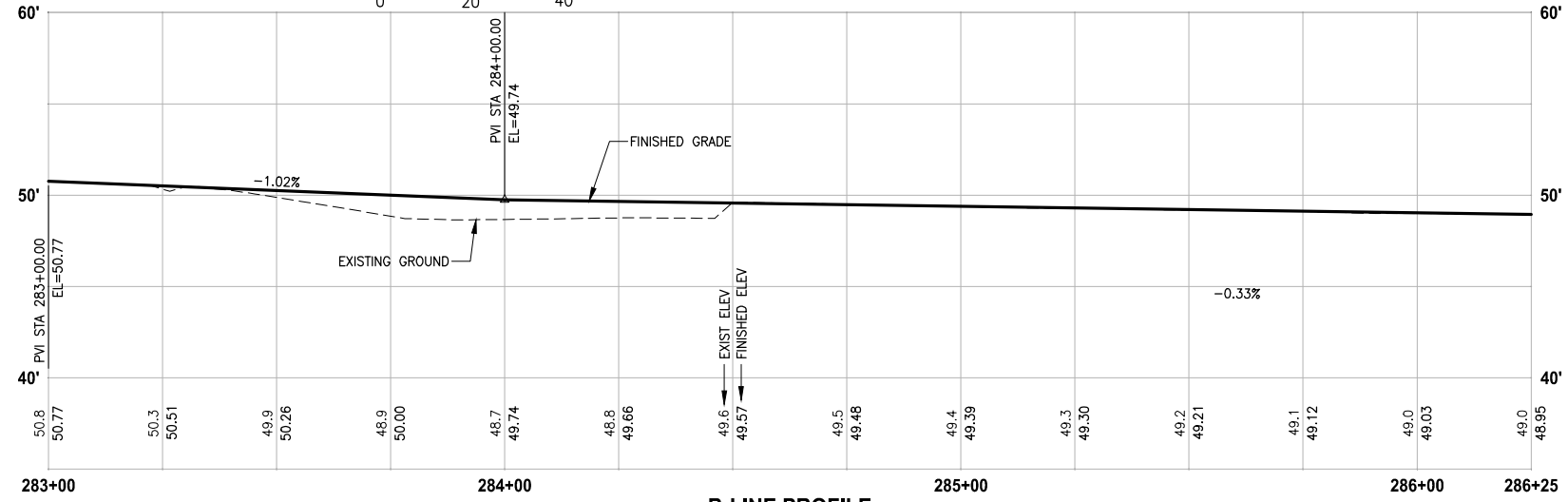
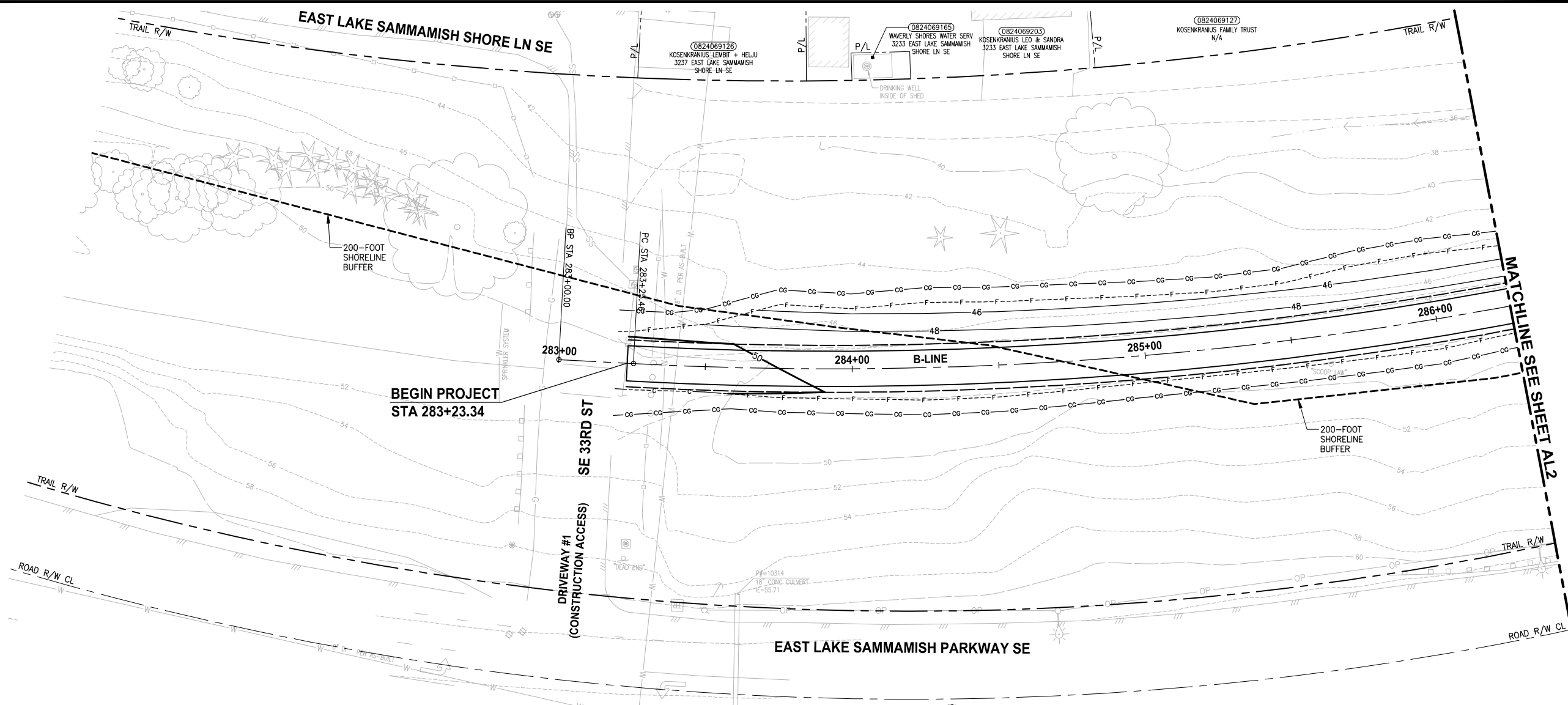
**Parametrix**  
ENGINEERING · PLANNING · ENVIRONMENTAL SCIENCES

719 2ND AVENUE, SUITE 200 | SEATTLE, WA 98104  
P 206.394.3700  
WWW.PARAMETRIX.COM

PROJECT NAME  
**EAST LAKE SAMMAMISH  
MASTER PLAN TRAIL  
SOUTH SAMMAMISH SEGMENT B**  
SAMMAMISH, WA

**LEGEND**

PATH: U:\PSO\Projects\Clients\1521-075-ELST\985\Drawings\1521-075-ELST\985\Drawings\CADD\Phase 19\T03\_Civil\Draw\Layout: AL1  
 PLOTTED BY: purgaban DATE: Wednesday, October 12, 2016 8:49:37 PM



**B-LINE PROFILE**  
 HORIZ: 1"=20'  
 VERT: 1"=5'

- CIVIL CONSTRUCTION NOTES:**
- 1 RESTORE AND INSTALL STAIR. TYPE TO BE DETERMINED.
  - 2 RECONSTRUCT PEDESTRIAN BRIDGE.
  - 3 INSTALL PRECAST REINF CONC SPLIT BOX CULVERT. SEE FP SHEETS FOR DETAILS.
  - 4 INSTALL STRUCTURAL EARTH WALL. SEE WALL DETAILS ON SHEET X. SEE WALL PROFILES ON WP SHEETS.
  - 5 INSTALL COATED CHAIN LINK FENCE TYPE 6. FOR GROUND POST INSTALLATION SEE APPENDIX B IN THE SPECIFICATIONS. SEE SHEET X FOR MOUNTING ON TOP OF WALL.
  - 6 NEW DRIVEWAY.
  - 7 INSTALL WOOD GUARDRAIL, SEE DETAILS ON SHEET XX.
  - 8 INSTALL SPLIT RAIL FENCE, SEE DETAILS ON SHEET XX.
  - 9 INSTALL GRAVITY BLOCK WALL. SEE WALL DETAILS ON SHEET WD1. SEE WALL PROFILES ON WP SHEETS.
  - 10 DRIVEWAY REMOVAL. SEE MP SHEETS FOR PLANTING PLAN.
  - 11 INSTALL PATTERNED CONCRETE DRIVEWAY. SEE DETAILS ON SHEET XX.
  - 12 INSTALL TYPE 1 REST STOP. SEE DETAILS ON SHEET XX.
  - 13 INSTALL TYPE 2 REST STOP. SEE DETAILS ON SHEET XX.
  - 14 INSTALL SOLDIER PILE WALL.
  - 15 INSTALL GRAVITY BLOCK WALL.
  - 16 INSTALL WING WALL, SEE FP SHEETS.
  - 17 INSTALL EXTRUDED CURB PER WSDOT STD PLAN F-10.42-00.
  - 18 REST STOP PULL-OUT.
  - 19 STAIRS WILL BE ELIMINATED DURING CONSTRUCTION.
  - 20 BRIDGES WILL BE REMOVED TO R/W LINE DURING CONSTRUCTION.
  - 21 INSTALL ROCK WALL.

- STORMWATER CONSTRUCTION NOTES:**
- 1 INFILTRATION TRENCH, SEE DETAIL 4 ON SHEET DD1.
  - 2 UNDERDRAIN TRENCH, SEE DETAIL 5 ON SHEET DD1.
  - 3 ROCK PAD, SEE DETAIL 2 ON SHEET DD1 AND WP SHEETS.
  - 4 CONNECTION TO DRAINAGE STRUCTURE AND CLEANING EXISTING DRAINAGE STRUCTURE.
  - 5 INSTALL UNDERDRAIN TRENCH CLEANOUT, SEE DETAIL 6 ON SHEET DD1.
  - 6 INSTALL RECTANGULAR SLIP RESISTANT SOLID METAL COVER PER WSDOT STD DETAIL B-30.20-02.
  - 7 CONCRETE HEADWALL, SEE DETAIL 1 ON SHEET DD1.
  - 8 BASIC DISPERSION, SEE SHEET CS3.
  - 9 QUARRY SPALL OUTFALL PROTECTION. SEE DETAIL 3 ON SHEET DD1.
  - 10 ADJUST CATCH BASIN.

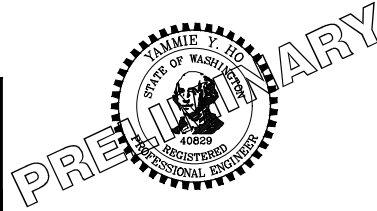
- LEGEND:**
- RETAINING WALL
  - SOLDIER PILE WALL
  - WOOD GUARDRAIL
  - DISPERSION AREA
  - DRIVEWAY REMOVAL

CITY OF SAMMAMISH APPROVAL	
City Engineer _____	Date _____
Community Development _____	Date _____

**60 % REVIEW SUBMITTAL**  
 NOT FOR CONSTRUCTION

REVISIONS	DATE	BY	DESIGNED
			M. TSUN
			B. PURGANAN
			P. JOHANNESSEN
			Y. HO

**ONE INCH AT FULL SCALE, IF NOT, SCALE ACCORDINGLY**  
 FILE NAME: BL1521075P19T03AL-01  
 JOB No: 554-1521-075 P19 T03  
 DATE: SEPTEMBER 2016



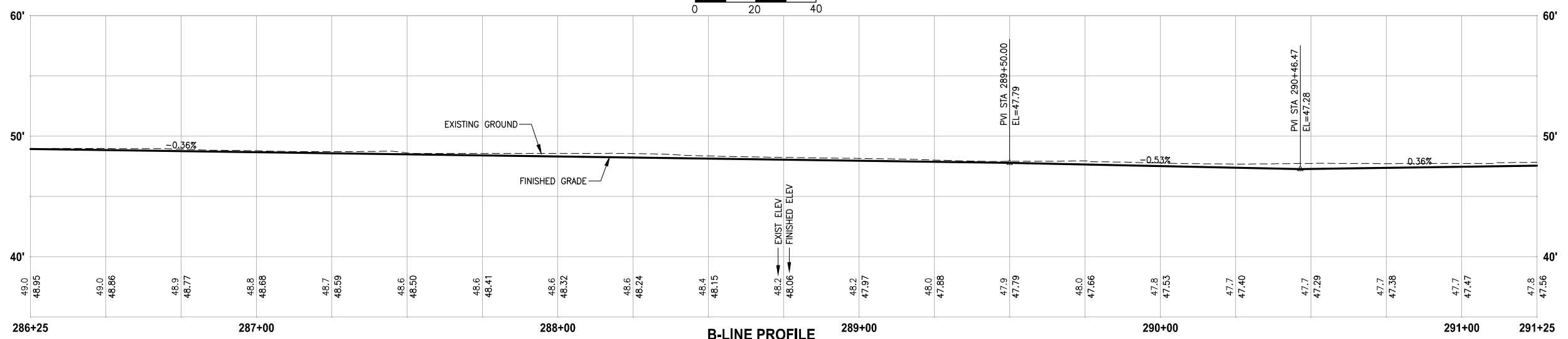
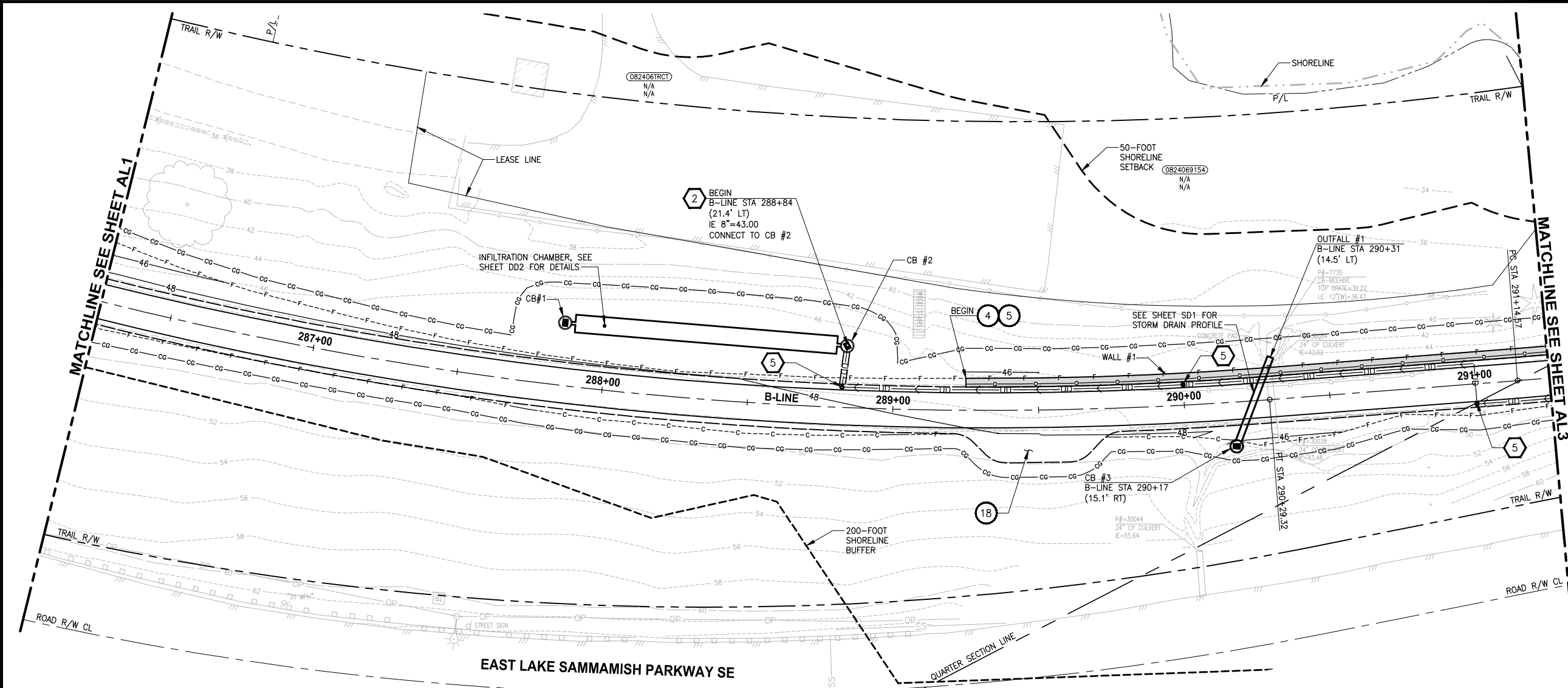
**Parametrix**  
 ENGINEERING · PLANNING · ENVIRONMENTAL SCIENCES  
 719 2ND AVENUE, SUITE 200 | SEATTLE, WA 98104  
 P 206.394.3700  
 WWW.PARAMETRIX.COM

PROJECT NAME  
**EAST LAKE SAMMAMISH MASTER PLAN TRAIL SOUTH SAMMAMISH SEGMENT B**  
 SAMMAMISH, WA

**PLAN AND PROFILE**

SHEET NO.  
 33 OF 135  
**AL1**

LAYOUT: AL2  
 PATH: U:\PSO\Projects\Clients\1521-KingCo\554-1521-075-ELST\99Secs\CADD\Phase 19\T03\_Civil\DWG\  
 PLOTTED BY: purgaban DATE: Wednesday, October 12, 2016 8:50:08 PM



- CIVIL CONSTRUCTION NOTES:**
- RESTORE AND INSTALL STAIR. TYPE TO BE DETERMINED.
  - RECONSTRUCT PEDESTRIAN BRIDGE.
  - INSTALL PRECAST REINF CONC SPLIT BOX CULVERT. SEE FP SHEETS FOR DETAILS.
  - INSTALL STRUCTURAL EARTH WALL. SEE WALL DETAILS ON SHEET X. SEE WALL PROFILES ON WP SHEETS.
  - INSTALL COATED CHAIN LINK FENCE TYPE 6. FOR GROUND POST INSTALLATION SEE APPENDIX B IN THE SPECIFICATIONS. SEE SHEET X FOR MOUNTING ON TOP OF WALL.
  - NEW DRIVEWAY.
  - INSTALL WOOD GUARDRAIL, SEE DETAILS ON SHEET XX.
  - INSTALL SPLIT RAIL FENCE, SEE DETAILS ON SHEET XX.
  - INSTALL GRAVITY BLOCK WALL. SEE WALL DETAILS ON SHEET WD1. SEE WALL PROFILES ON WP SHEETS.
  - DRIVEWAY REMOVAL. SEE MP SHEETS FOR PLANTING PLAN.
  - INSTALL PATTERNED CONCRETE DRIVEWAY. SEE DETAILS ON SHEET XX.
  - INSTALL TYPE 1 REST STOP. SEE DETAILS ON SHEET XX.
  - INSTALL TYPE 2 REST STOP. SEE DETAILS ON SHEET XX.
  - INSTALL SOLDIER PILE WALL.
  - INSTALL GRAVITY BLOCK WALL.
  - INSTALL WING WALL, SEE FP SHEETS.
  - INSTALL EXTRUDED CURB PER WSDOT STD PLAN F-10.42-00.
  - REST STOP PULL-OUT.
  - STAIRS WILL BE ELIMINATED DURING CONSTRUCTION.
  - BRIDGES WILL BE REMOVED TO R/W LINE DURING CONSTRUCTION.
  - INSTALL ROCK WALL.

- STORMWATER CONSTRUCTION NOTES:**
- INFILTRATION TRENCH, SEE DETAIL 4 ON SHEET DD1.
  - UNDERDRAIN TRENCH, SEE DETAIL 5 ON SHEET DD1.
  - ROCK PAD, SEE DETAIL 2 ON SHEET DD1 AND WP SHEETS.
  - CONNECTION TO DRAINAGE STRUCTURE AND CLEANING EXISTING DRAINAGE STRUCTURE.
  - INSTALL UNDERDRAIN TRENCH CLEANOUT, SEE DETAIL 6 ON SHEET DD1.
  - INSTALL RECTANGULAR SLIP RESISTANT SOLID METAL COVER PER WSDOT STD DETAIL B-30.20-02.
  - CONCRETE HEADWALL, SEE DETAIL 1 ON SHEET DD1.
  - BASIC DISPERSION, SEE SHEET CS3.
  - QUARRY SPALL OUTFALL PROTECTION. SEE DETAIL 3 ON SHEET DD1.
  - ADJUST CATCH BASIN.

- LEGEND:**
- RETAINING WALL
  - SOLDIER PILE WALL
  - WOOD GUARDRAIL
  - DISPERSION AREA
  - DRIVEWAY REMOVAL

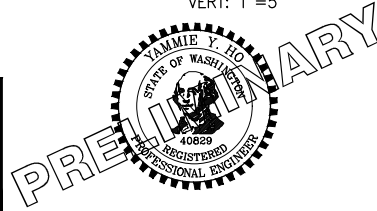
**CITY OF SAMMAMISH APPROVAL**

City Engineer _____	Date _____
Community Development _____	Date _____

**60 % REVIEW SUBMITTAL**  
NOT FOR CONSTRUCTION

NO.	REVISIONS	DATE	BY	DESIGNED
				M. TSUN
				B. PURGANAN
				P. JOHANNESSEN
				Y. HO

**ONE INCH AT FULL SCALE, IF NOT, SCALE ACCORDINGLY**  
 FILE NAME: BL1521075P19T03AL-01  
 JOB No.: 554-1521-075 P19 T03  
 DATE: SEPTEMBER 2016



**Parametrix**  
 ENGINEERING · PLANNING · ENVIRONMENTAL SCIENCES  
 719 2ND AVENUE, SUITE 200 | SEATTLE, WA 98104  
 P 206.394.3700  
 WWW.PARAMETRIX.COM

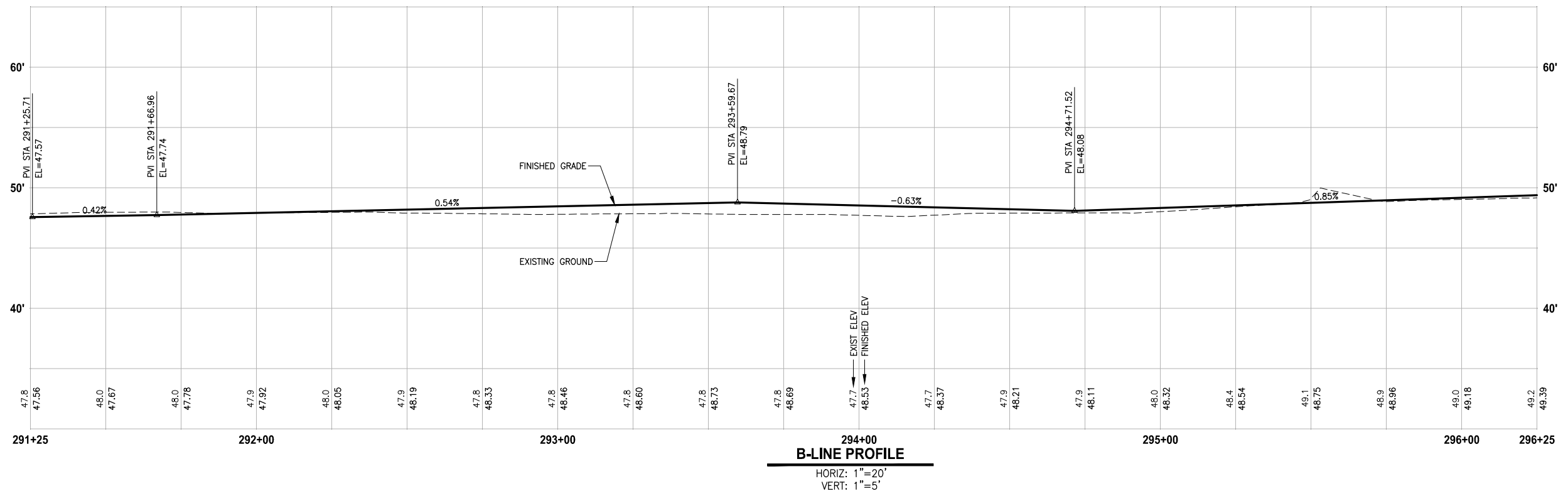
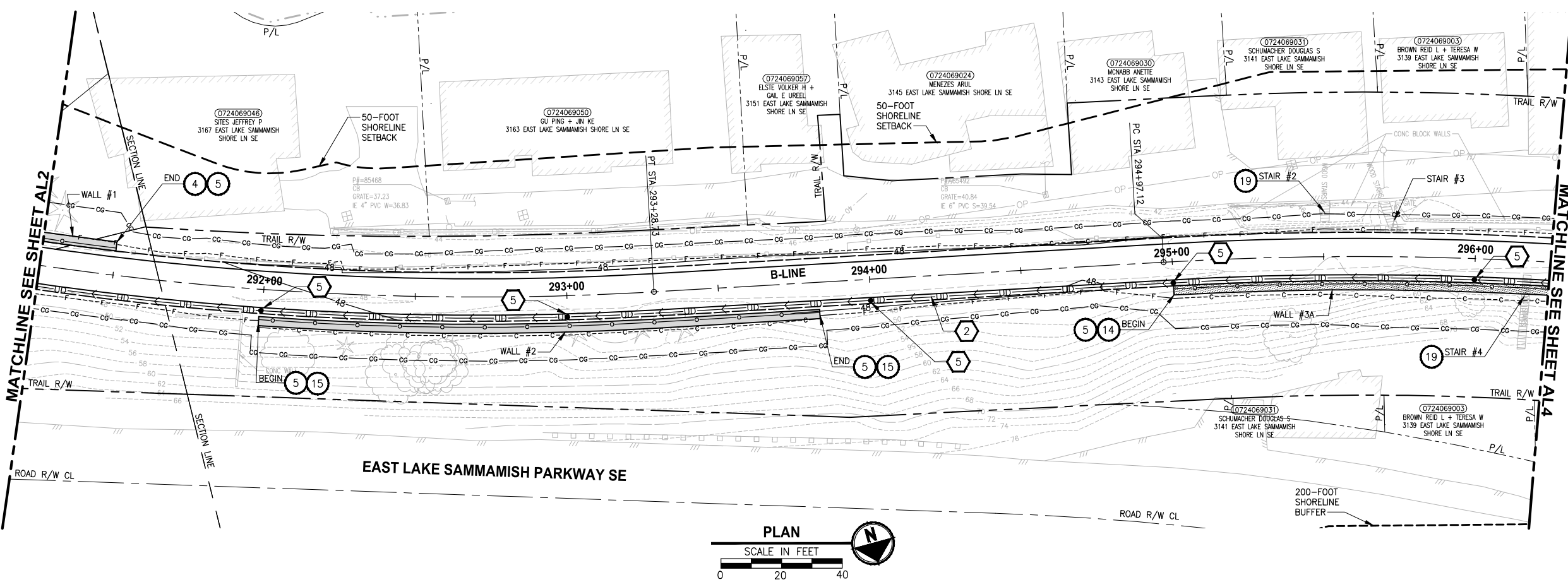
PROJECT NAME  
**EAST LAKE SAMMAMISH MASTER PLAN TRAIL SOUTH SAMMAMISH SEGMENT B**  
 SAMMAMISH, WA

**PLAN AND PROFILE**

SHEET NO.  
 34 OF 135  
**AL2**



U:\PSO\Projects\Clients\1521-KingCo\554-1521-075-ELSA\99Secs\CADD\Phase 19\T03\_Civil\Draw\ PLOTTED BY: purgaban, DATE: Wednesday, October 12, 2016 8:50:39 PM LAYOUT: AL3



- CIVIL CONSTRUCTION NOTES:**
- RESTORE AND INSTALL STAIR. TYPE TO BE DETERMINED.
  - RECONSTRUCT PEDESTRIAN BRIDGE.
  - INSTALL PRECAST REINF CONC SPLIT BOX CULVERT. SEE FP SHEETS FOR DETAILS.
  - INSTALL STRUCTURAL EARTH WALL. SEE WALL DETAILS ON SHEET X. SEE WALL PROFILES ON WP SHEETS.
  - INSTALL COATED CHAIN LINK FENCE TYPE 6. FOR GROUND POST INSTALLATION SEE APPENDIX B IN THE SPECIFICATIONS. SEE SHEET X FOR MOUNTING ON TOP OF WALL.
  - NEW DRIVEWAY.
  - INSTALL WOOD GUARDRAIL, SEE DETAILS ON SHEET XX.
  - INSTALL SPLIT RAIL FENCE, SEE DETAILS ON SHEET XX.
  - INSTALL GRAVITY BLOCK WALL. SEE WALL DETAILS ON SHEET WD1. SEE WALL PROFILES ON WP SHEETS.
  - DRIVEWAY REMOVAL. SEE MP SHEETS FOR PLANTING PLAN.
  - INSTALL PATTERNED CONCRETE DRIVEWAY. SEE DETAILS ON SHEET XX.
  - INSTALL TYPE 1 REST STOP. SEE DETAILS ON SHEET XX.
  - INSTALL TYPE 2 REST STOP. SEE DETAILS ON SHEET XX.
  - INSTALL SOLDIER PILE WALL.
  - INSTALL GRAVITY BLOCK WALL.
  - INSTALL WING WALL, SEE FP SHEETS.
  - INSTALL EXTRUDED CURB PER WSDOT STD PLAN F-10.42-00.
  - REST STOP PULL-OUT.
  - STAIRS WILL BE ELIMINATED DURING CONSTRUCTION.
  - BRIDGES WILL BE REMOVED TO R/W LINE DURING CONSTRUCTION.
  - INSTALL ROCK WALL.

- STORMWATER CONSTRUCTION NOTES:**
- INFILTRATION TRENCH, SEE DETAIL 4 ON SHEET DD1.
  - UNDERDRAIN TRENCH, SEE DETAIL 5 ON SHEET DD1.
  - ROCK PAD, SEE DETAIL 2 ON SHEET DD1 AND WP SHEETS.
  - CONNECTION TO DRAINAGE STRUCTURE AND CLEANING EXISTING DRAINAGE STRUCTURE.
  - INSTALL UNDERDRAIN TRENCH CLEANOUT, SEE DETAIL 6 ON SHEET DD1.
  - INSTALL RECTANGULAR SLIP RESISTANT SOLID METAL COVER PER WSDOT STD DETAIL B-30.20-02.
  - CONCRETE HEADWALL, SEE DETAIL 1 ON SHEET DD1.
  - BASIC DISPERSION, SEE SHEET CS3.
  - QUARRY SPALL OUTFALL PROTECTION. SEE DETAIL 3 ON SHEET DD1.
  - ADJUST CATCH BASIN.

- LEGEND:**
- RETAINING WALL
  - SOLDIER PILE WALL
  - WOOD GUARDRAIL
  - DISPERSION AREA
  - DRIVEWAY REMOVAL

**CITY OF SAMMAMISH APPROVAL**

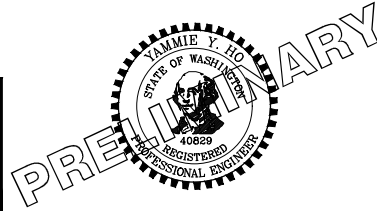
City Engineer _____	Date _____
Community Development _____	Date _____

**60% REVIEW SUBMITTAL**  
NOT FOR CONSTRUCTION

REVISIONS	DATE	BY	DESIGNED
			M. TSUN
			B. PURGANAN
			P. JOHANNESSEN
			Y. HO

**ONE INCH AT FULL SCALE, IF NOT, SCALE ACCORDINGLY**

FILE NAME: BL1521075P19T03AL-01  
JOB No: 554-1521-075 P19 T03  
DATE: SEPTEMBER 2016



**Parametrix**  
ENGINEERING · PLANNING · ENVIRONMENTAL SCIENCES

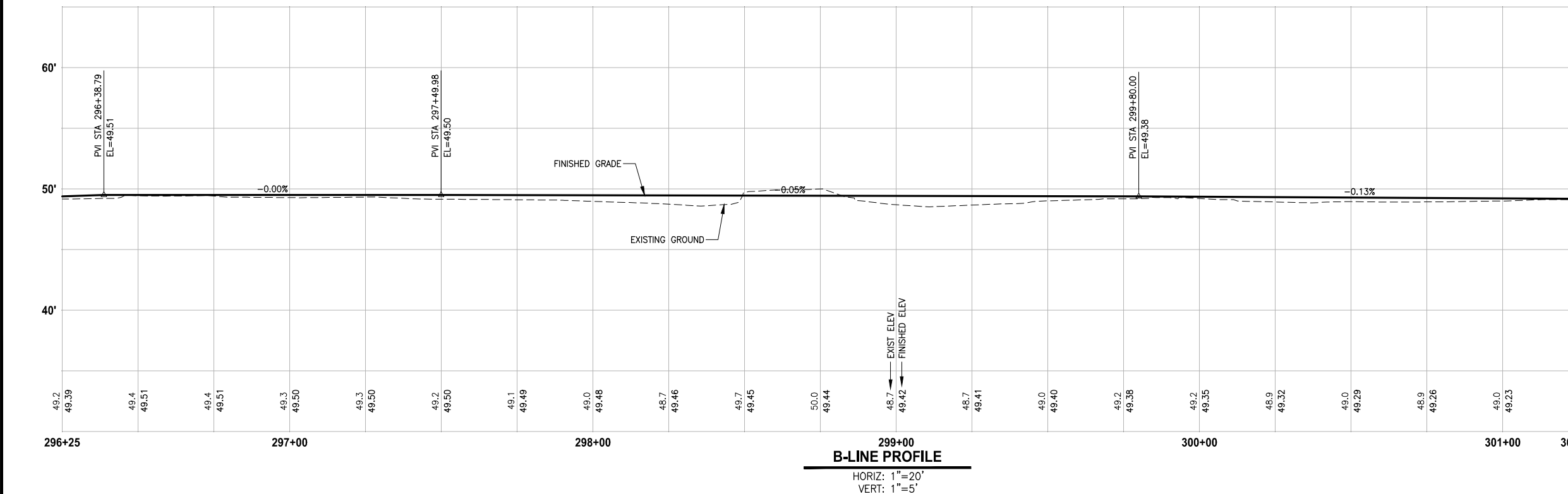
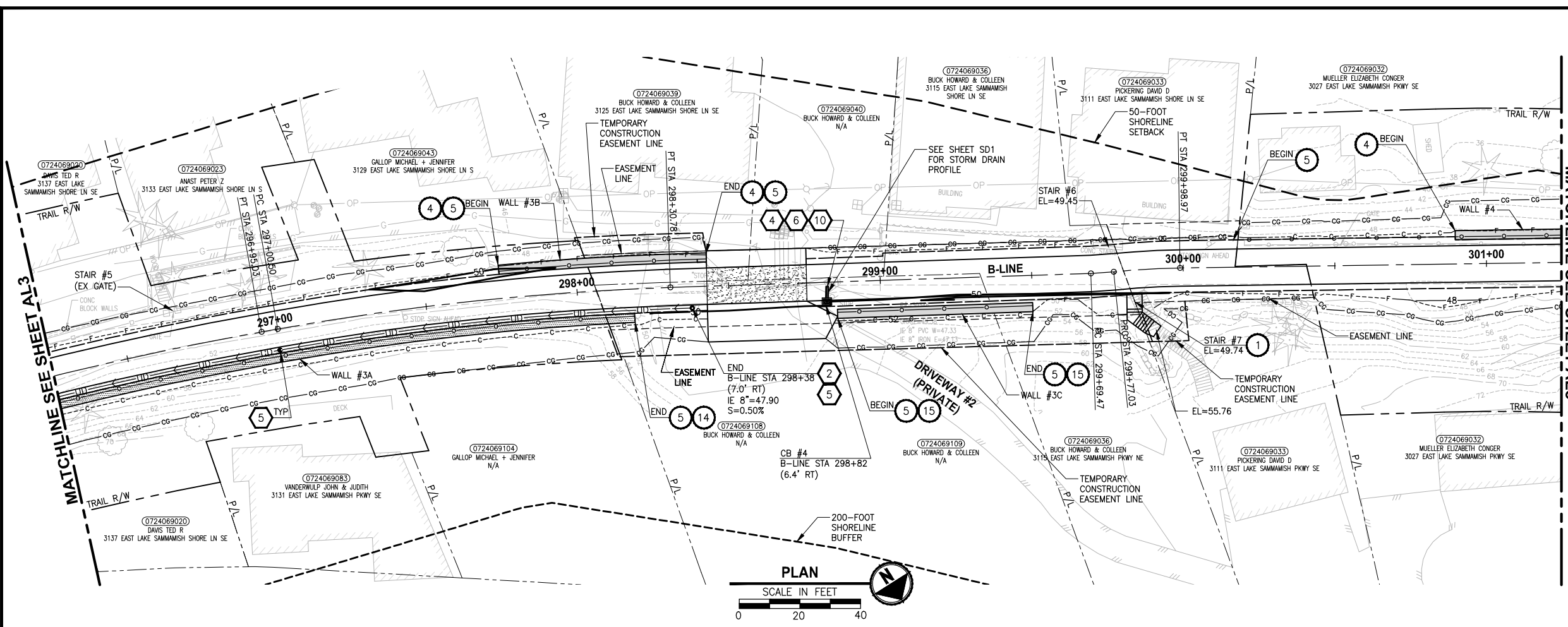
719 2ND AVENUE, SUITE 200 | SEATTLE, WA 98104  
P 206.394.3700  
WWW.PARAMETRIX.COM

PROJECT NAME  
**EAST LAKE SAMMAMISH MASTER PLAN TRAIL SOUTH SAMMAMISH SEGMENT B**  
SAMMAMISH, WA

**PLAN AND PROFILE**

SHEET NO.  
35 OF 135  
**AL3**

PATH: U:\PSO\Projects\Clients\1521-075-ELST\99Secs\CADD\Phase 19\T03 CIV\DWG\ PLOTTED BY: purgubut DATE: Wednesday, October 12, 2016 8:51:10 PM LAYOUT: AL4



- CIVIL CONSTRUCTION NOTES:**
- 1 RESTORE AND INSTALL STAIR. TYPE TO BE DETERMINED.
  - 2 RECONSTRUCT PEDESTRIAN BRIDGE.
  - 3 INSTALL PRECAST REINF CONC SPLIT BOX CULVERT. SEE FP SHEETS FOR DETAILS.
  - 4 INSTALL STRUCTURAL EARTH WALL. SEE WALL DETAILS ON SHEET X. SEE WALL PROFILES ON WP SHEETS.
  - 5 INSTALL COATED CHAIN LINK FENCE TYPE 6. FOR GROUND POST INSTALLATION SEE APPENDIX B IN THE SPECIFICATIONS. SEE SHEET X FOR MOUNTING ON TOP OF WALL.
  - 6 NEW DRIVEWAY.
  - 7 INSTALL WOOD GUARDRAIL, SEE DETAILS ON SHEET XX.
  - 8 INSTALL SPLIT RAIL FENCE, SEE DETAILS ON SHEET XX.
  - 9 INSTALL GRAVITY BLOCK WALL. SEE WALL DETAILS ON SHEET WD1. SEE WALL PROFILES ON WP SHEETS.
  - 10 DRIVEWAY REMOVAL. SEE MP SHEETS FOR PLANTING PLAN.
  - 11 INSTALL PATTERNED CONCRETE DRIVEWAY. SEE DETAILS ON SHEET XX.
  - 12 INSTALL TYPE 1 REST STOP. SEE DETAILS ON SHEET XX.
  - 13 INSTALL TYPE 2 REST STOP. SEE DETAILS ON SHEET XX.
  - 14 INSTALL SOLDIER PILE WALL.
  - 15 INSTALL GRAVITY BLOCK WALL.
  - 16 INSTALL WING WALL, SEE FP SHEETS.
  - 17 INSTALL EXTRUDED CURB PER WSDOT STD PLAN F-10.42-00.
  - 18 REST STOP PULL-OUT.
  - 19 STAIRS WILL BE ELIMINATED DURING CONSTRUCTION.
  - 20 BRIDGES WILL BE REMOVED TO R/W LINE DURING CONSTRUCTION.
  - 21 INSTALL ROCK WALL.

- STORMWATER CONSTRUCTION NOTES:**
- 1 INFILTRATION TRENCH, SEE DETAIL 4 ON SHEET DD1.
  - 2 UNDERDRAIN TRENCH, SEE DETAIL 5 ON SHEET DD1.
  - 3 ROCK PAD, SEE DETAIL 2 ON SHEET DD1 AND WP SHEETS.
  - 4 CONNECTION TO DRAINAGE STRUCTURE AND CLEANING EXISTING DRAINAGE STRUCTURE.
  - 5 INSTALL UNDERDRAIN TRENCH CLEANOUT, SEE DETAIL 6 ON SHEET DD1.
  - 6 INSTALL RECTANGULAR SLIP RESISTANT SOLID METAL COVER PER WSDOT STD DETAIL B-30.20-02.
  - 7 CONCRETE HEADWALL, SEE DETAIL 1 ON SHEET DD1.
  - 8 BASIC DISPERSION, SEE SHEET CS3.
  - 9 QUARRY SPALL OUTFALL PROTECTION. SEE DETAIL 3 ON SHEET DD1.
  - 10 ADJUST CATCH BASIN.

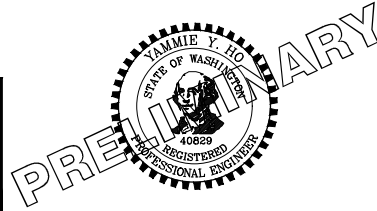
- LEGEND:**
- RETAINING WALL
  - SOLDIER PILE WALL
  - WOOD GUARDRAIL
  - DISPERSION AREA
  - DRIVEWAY REMOVAL

CITY OF SAMMAMISH APPROVAL	
City Engineer _____	Date _____
Community Development _____	Date _____

**60 % REVIEW SUBMITTAL  
NOT FOR CONSTRUCTION**

REVISIONS	DATE	BY	DESIGNED
			M. TSUN
			B. PURGANAN
			P. JOHANNESSEN
			Y. HO

**ONE INCH AT FULL SCALE, IF NOT, SCALE ACCORDINGLY**  
 FILE NAME: BL1521075P19T03AL-01  
 JOB No.: 554-1521-075 P19 T03  
 DATE: SEPTEMBER 2016



**Parametrix**  
 ENGINEERING · PLANNING · ENVIRONMENTAL SCIENCES  
 719 2ND AVENUE, SUITE 200 | SEATTLE, WA 98104  
 P 206.394.3700  
 WWW.PARAMETRIX.COM

PROJECT NAME  
**EAST LAKE SAMMAMISH  
 MASTER PLAN TRAIL  
 SOUTH SAMMAMISH SEGMENT B**  
 SAMMAMISH, WA

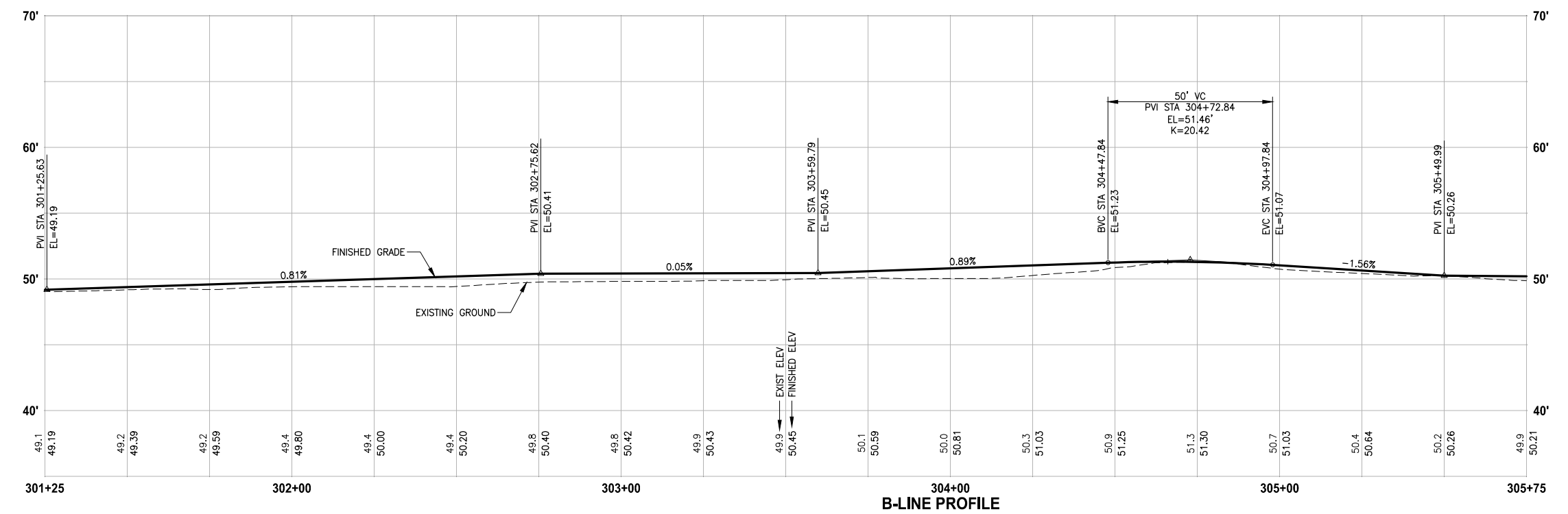
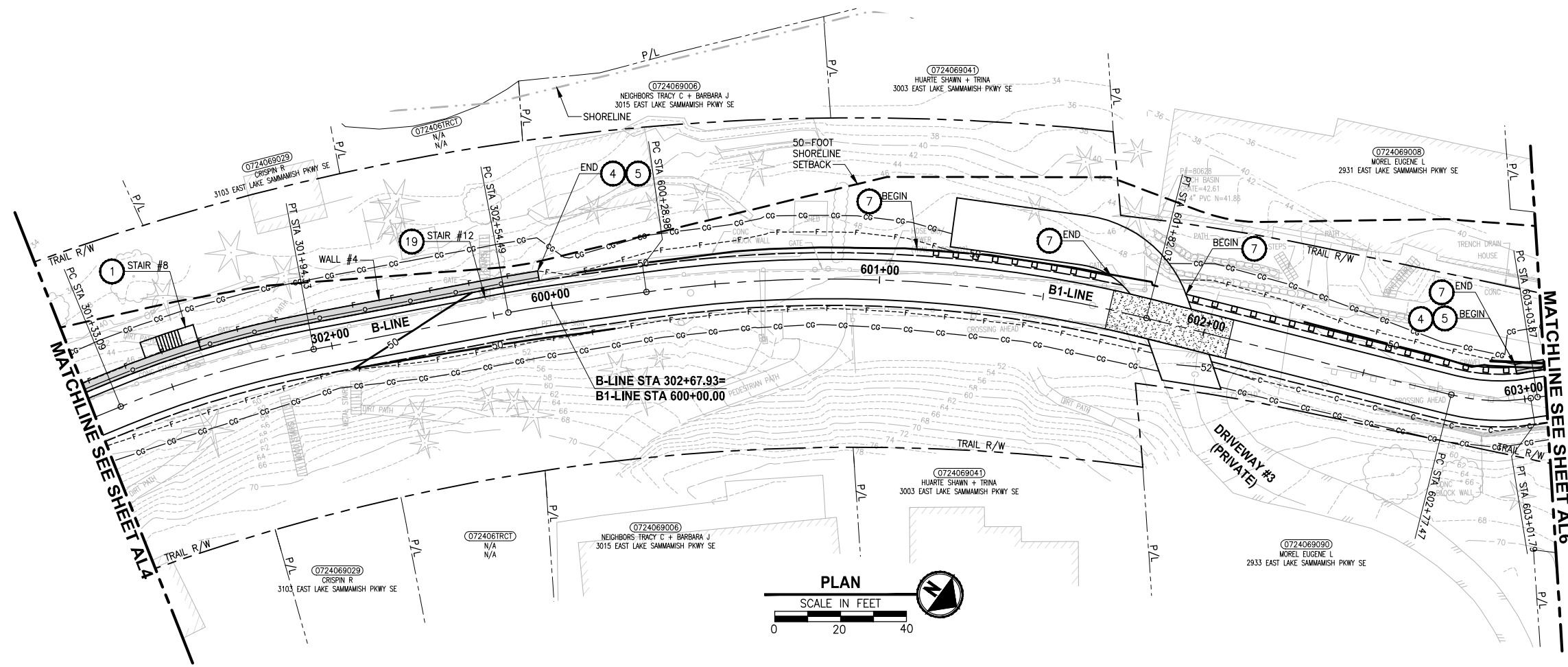
PLAN AND PROFILE

SHEET NO.  
36 OF 135

AL4



PATH: U:\PSO\Projects\Clients\1521-KingCo\554-1521-075-ELST\99Svcs\CADD\Phase 19\T03\_Civil\Draw\ PLOTTED BY: purgubut DATE: Wednesday, October 12, 2016 8:51:40 PM LAYOUT: AL5



- CIVIL CONSTRUCTION NOTES:**
- RESTORE AND INSTALL STAIR. TYPE TO BE DETERMINED.
  - RECONSTRUCT PEDESTRIAN BRIDGE.
  - INSTALL PRECAST REINF CONC SPLIT BOX CULVERT. SEE FP SHEETS FOR DETAILS.
  - INSTALL STRUCTURAL EARTH WALL. SEE WALL DETAILS ON SHEET X. SEE WALL PROFILES ON WP SHEETS.
  - INSTALL COATED CHAIN LINK FENCE TYPE 6. FOR GROUND POST INSTALLATION SEE APPENDIX B IN THE SPECIFICATIONS. SEE SHEET X FOR MOUNTING ON TOP OF WALL.
  - NEW DRIVEWAY.
  - INSTALL WOOD GUARDRAIL, SEE DETAILS ON SHEET XX.
  - INSTALL SPLIT RAIL FENCE, SEE DETAILS ON SHEET XX.
  - INSTALL GRAVITY BLOCK WALL. SEE WALL DETAILS ON SHEET WD1. SEE WALL PROFILES ON WP SHEETS.
  - DRIVEWAY REMOVAL. SEE MP SHEETS FOR PLANTING PLAN.
  - INSTALL PATTERNED CONCRETE DRIVEWAY. SEE DETAILS ON SHEET XX.
  - INSTALL TYPE 1 REST STOP. SEE DETAILS ON SHEET XX.
  - INSTALL TYPE 2 REST STOP. SEE DETAILS ON SHEET XX.
  - INSTALL SOLDIER PILE WALL.
  - INSTALL GRAVITY BLOCK WALL.
  - INSTALL WING WALL, SEE FP SHEETS.
  - INSTALL EXTRUDED CURB PER WSDOT STD PLAN F-10.42-00.
  - REST STOP PULL-OUT.
  - STAIRS WILL BE ELIMINATED DURING CONSTRUCTION.
  - BRIDGES WILL BE REMOVED TO R/W LINE DURING CONSTRUCTION.
  - INSTALL ROCK WALL.

- STORMWATER CONSTRUCTION NOTES:**
- INFILTRATION TRENCH, SEE DETAIL 4 ON SHEET DD1.
  - UNDERDRAIN TRENCH, SEE DETAIL 5 ON SHEET DD1.
  - ROCK PAD, SEE DETAIL 2 ON SHEET DD1 AND WP SHEETS.
  - CONNECTION TO DRAINAGE STRUCTURE AND CLEANING EXISTING DRAINAGE STRUCTURE.
  - INSTALL UNDERDRAIN TRENCH CLEANOUT, SEE DETAIL 6 ON SHEET DD1.
  - INSTALL RECTANGULAR SLIP RESISTANT SOLID METAL COVER PER WSDOT STD DETAIL B-30.20-02.
  - CONCRETE HEADWALL, SEE DETAIL 1 ON SHEET DD1.
  - BASIC DISPERSION, SEE SHEET CS3.
  - QUARRY SPALL OUTFALL PROTECTION. SEE DETAIL 3 ON SHEET DD1.
  - ADJUST CATCH BASIN.

- LEGEND:**
- RETAINING WALL
  - SOLDIER PILE WALL
  - WOOD GUARDRAIL
  - DISPERSION AREA
  - DRIVEWAY REMOVAL

**CITY OF SAMMAMISH APPROVAL**

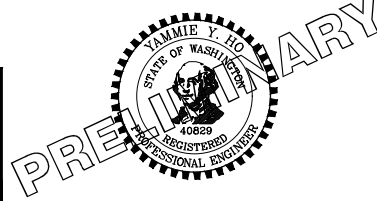
City Engineer _____	Date _____
Community Development _____	Date _____

**60% REVIEW SUBMITTAL**  
NOT FOR CONSTRUCTION

REVISIONS	DATE	BY	DESIGNED
			M. TSUN
			B. PURGANAN
			P. JOHANNESSEN
			Y. HO

**ONE INCH AT FULL SCALE, IF NOT, SCALE ACCORDINGLY**

FILE NAME: BL1521075P19T03AL-01  
JOB No.: 554-1521-075 P19 T03  
DATE: SEPTEMBER 2016



**Parametrix**  
ENGINEERING · PLANNING · ENVIRONMENTAL SCIENCES

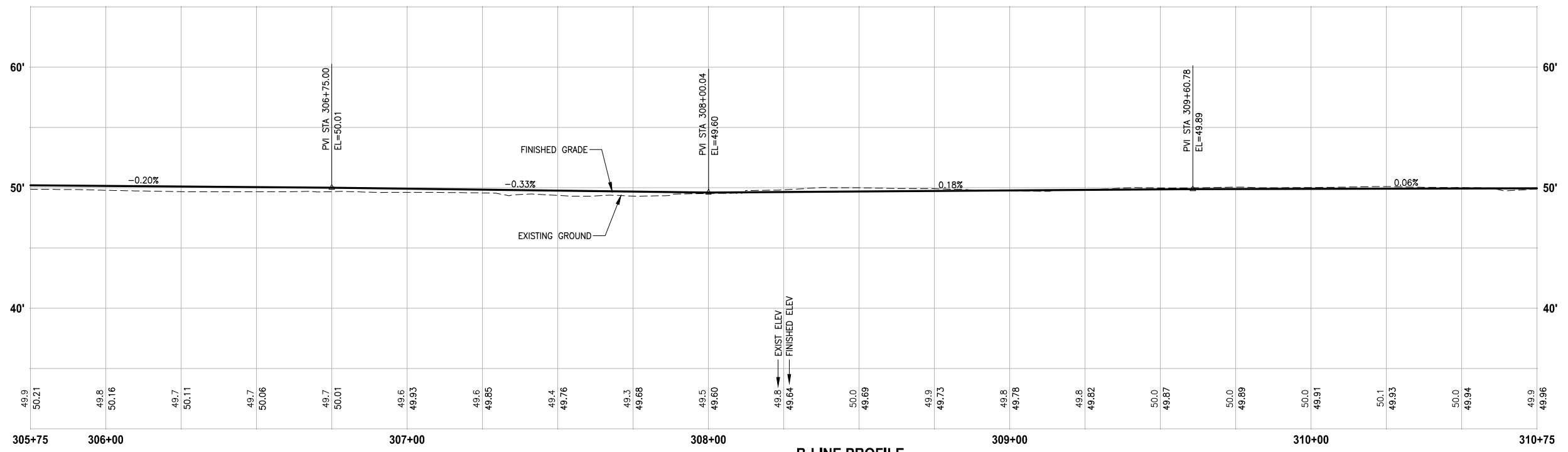
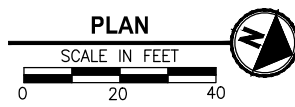
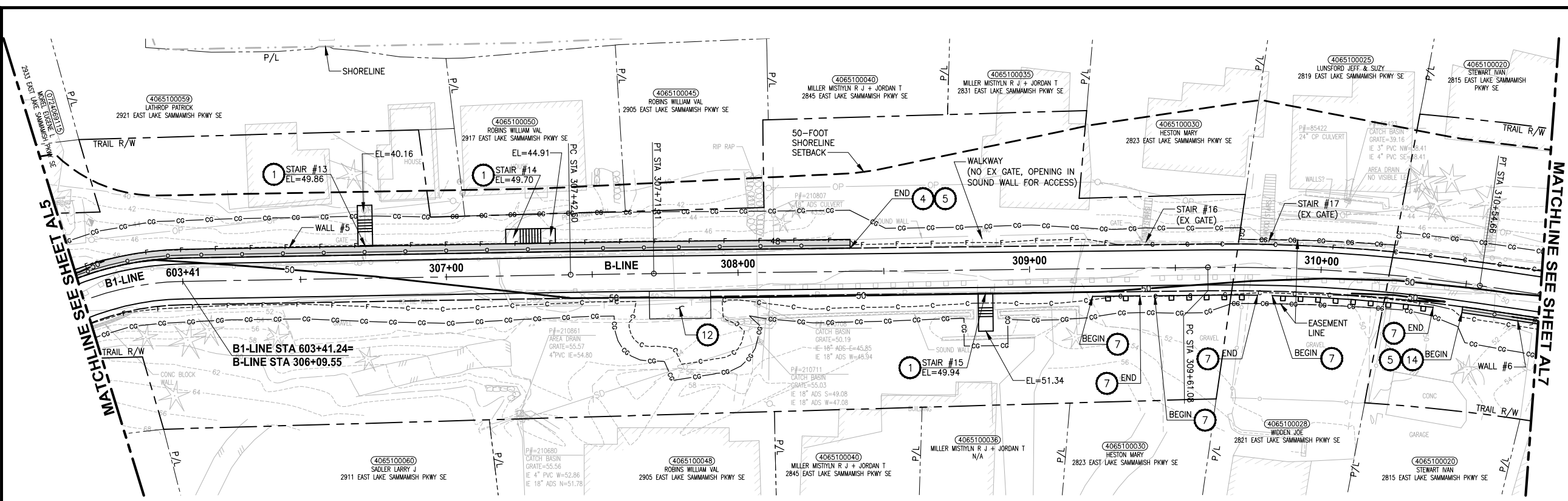
719 2ND AVENUE, SUITE 200 | SEATTLE, WA 98104  
P 206.394.3700  
WWW.PARAMETRIX.COM

PROJECT NAME  
**EAST LAKE SAMMAMISH MASTER PLAN TRAIL SOUTH SAMMAMISH SEGMENT B**  
SAMMAMISH, WA

**PLAN AND PROFILE**

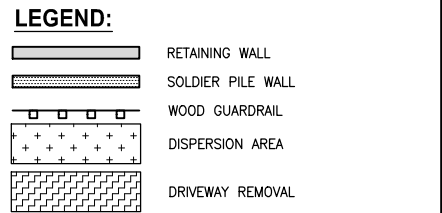
SHEET NO.  
37 OF 135  
**AL5**

PATH: U:\PSO\Projects\Clients\1521-075-ELST\99Svcs\CA00\Phase 19\T03 CIVIL\DWG\ PLOTTED BY: purgabat DATE: Wednesday, October 12, 2016 8:52:10 PM LAYOUT: AL6



- CIVIL CONSTRUCTION NOTES:**
- RESTORE AND INSTALL STAIR. TYPE TO BE DETERMINED.
  - RECONSTRUCT PEDESTRIAN BRIDGE.
  - INSTALL PRECAST REINF CONC SPLIT BOX CULVERT. SEE FP SHEETS FOR DETAILS.
  - INSTALL STRUCTURAL EARTH WALL. SEE WALL DETAILS ON SHEET X. SEE WALL PROFILES ON WP SHEETS.
  - INSTALL COATED CHAIN LINK FENCE TYPE 6. FOR GROUND POST INSTALLATION SEE APPENDIX B IN THE SPECIFICATIONS. SEE SHEET X FOR MOUNTING ON TOP OF WALL.
  - NEW DRIVEWAY.
  - INSTALL WOOD GUARDRAIL, SEE DETAILS ON SHEET XX.
  - INSTALL SPLIT RAIL FENCE, SEE DETAILS ON SHEET XX.
  - INSTALL GRAVITY BLOCK WALL. SEE WALL DETAILS ON SHEET WD1. SEE WALL PROFILES ON WP SHEETS.
  - DRIVEWAY REMOVAL. SEE MP SHEETS FOR PLANTING PLAN.
  - INSTALL PATTERNED CONCRETE DRIVEWAY. SEE DETAILS ON SHEET XX.
  - INSTALL TYPE 1 REST STOP. SEE DETAILS ON SHEET XX.
  - INSTALL TYPE 2 REST STOP. SEE DETAILS ON SHEET XX.
  - INSTALL SOLDIER PILE WALL.
  - INSTALL GRAVITY BLOCK WALL.
  - INSTALL WING WALL, SEE FP SHEETS.
  - INSTALL EXTRUDED CURB PER WSDOT STD PLAN F-10.42-00.
  - REST STOP PULL-OUT.
  - STAIRS WILL BE ELIMINATED DURING CONSTRUCTION.
  - BRIDGES WILL BE REMOVED TO R/W LINE DURING CONSTRUCTION.
  - INSTALL ROCK WALL.

- STORMWATER CONSTRUCTION NOTES:**
- INFILTRATION TRENCH, SEE DETAIL 4 ON SHEET DD1.
  - UNDERDRAIN TRENCH, SEE DETAIL 5 ON SHEET DD1.
  - ROCK PAD, SEE DETAIL 2 ON SHEET DD1 AND WP SHEETS.
  - CONNECTION TO DRAINAGE STRUCTURE AND CLEANING EXISTING DRAINAGE STRUCTURE.
  - INSTALL UNDERDRAIN TRENCH CLEANOUT, SEE DETAIL 6 ON SHEET DD1.
  - INSTALL RECTANGULAR SLIP RESISTANT SOLID METAL COVER PER WSDOT STD DETAIL B-30.20-02.
  - CONCRETE HEADWALL, SEE DETAIL 1 ON SHEET DD1.
  - BASIC DISPERSION, SEE SHEET CS3.
  - QUARRY SPALL OUTFALL PROTECTION. SEE DETAIL 3 ON SHEET DD1.
  - ADJUST CATCH BASIN.



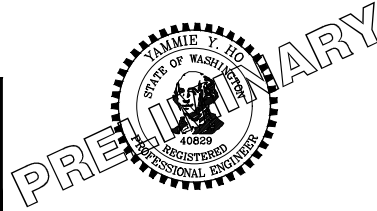
**CITY OF SAMMAMISH APPROVAL**

City Engineer _____	Date _____
Community Development _____	Date _____

**60% REVIEW SUBMITTAL**  
NOT FOR CONSTRUCTION

REVISIONS	DATE	BY	DESIGNED
			M. TSUN
			B. PURGANAN
			P. JOHANNESSEN
			Y. HO

**ONE INCH AT FULL SCALE, IF NOT, SCALE ACCORDINGLY**  
 FILE NAME: BL1521075P19T03AL-01  
 JOB No.: 554-1521-075 P19 T03  
 DATE: SEPTEMBER 2016



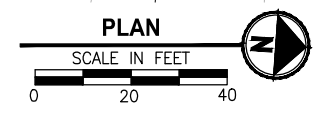
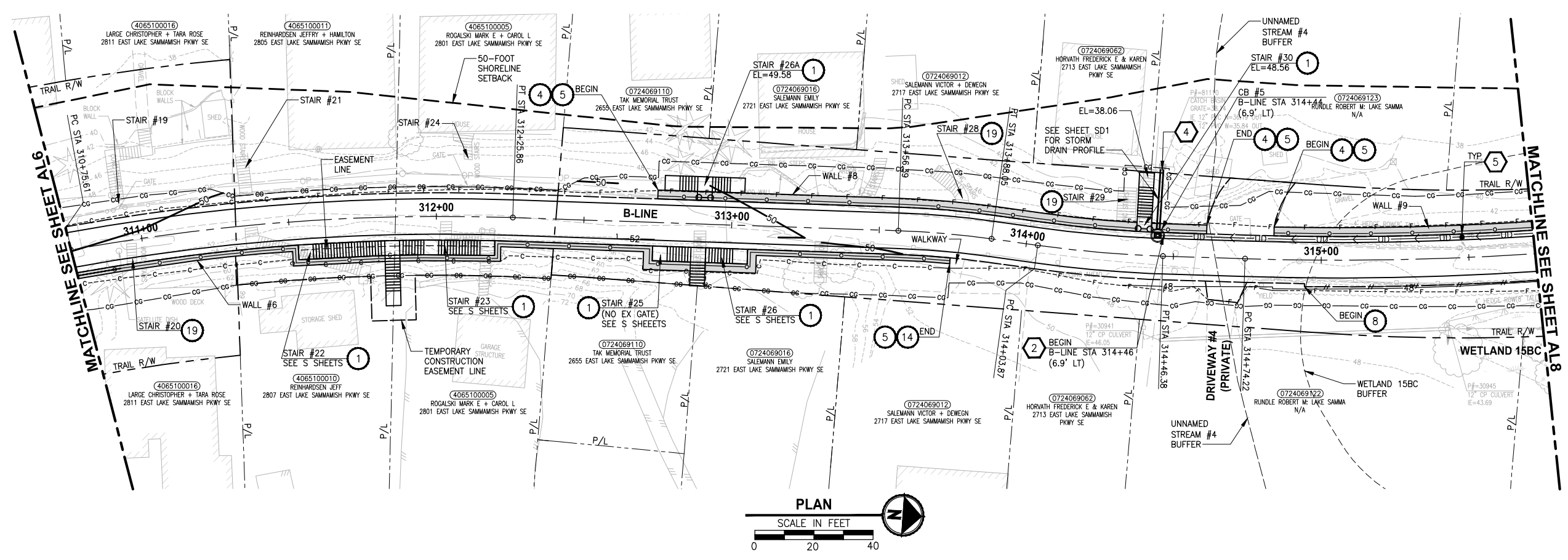
**Parametrix**  
 ENGINEERING · PLANNING · ENVIRONMENTAL SCIENCES  
 719 2ND AVENUE, SUITE 200 | SEATTLE, WA 98104  
 P 206.394.3700  
 WWW.PARAMETRIX.COM

PROJECT NAME  
**EAST LAKE SAMMAMISH MASTER PLAN TRAIL SOUTH SAMMAMISH SEGMENT B**  
 SAMMAMISH, WA

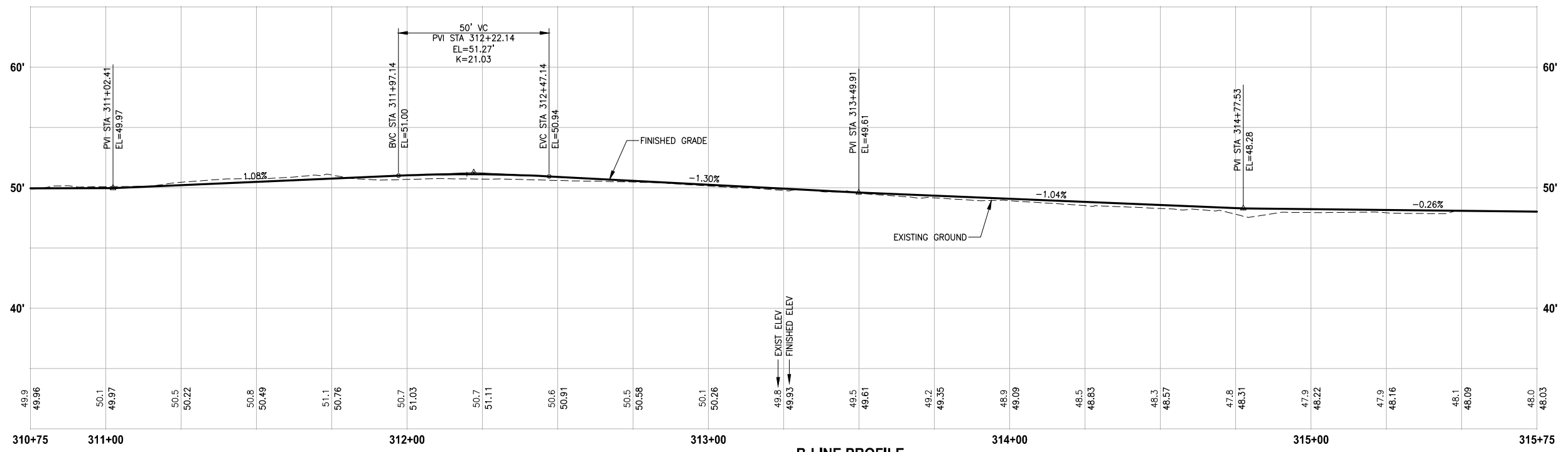
**PLAN AND PROFILE**  
 SHEET NO. 38 OF 135  
**AL6**



U:\PSO\Projects\Clients\1521-075-ELST\99\Drawings\Phase 19\T03 CIV\AL7.dwg PLOTTED BY: purgabat DATE: Wednesday, October 12, 2016 8:52:38 PM



- CIVIL CONSTRUCTION NOTES:**
- RESTORE AND INSTALL STAIR. TYPE TO BE DETERMINED.
  - RECONSTRUCT PEDESTRIAN BRIDGE.
  - INSTALL PRECAST REINF CONC SPLIT BOX CULVERT. SEE FP SHEETS FOR DETAILS.
  - INSTALL STRUCTURAL EARTH WALL. SEE WALL DETAILS ON SHEET X. SEE WALL PROFILES ON WP SHEETS.
  - INSTALL COATED CHAIN LINK FENCE TYPE 6. FOR GROUND POST INSTALLATION SEE APPENDIX B IN THE SPECIFICATIONS. SEE SHEET X FOR MOUNTING ON TOP OF WALL.
  - NEW DRIVEWAY.
  - INSTALL WOOD GUARDRAIL, SEE DETAILS ON SHEET XX.
  - INSTALL SPLIT RAIL FENCE, SEE DETAILS ON SHEET XX.
  - INSTALL GRAVITY BLOCK WALL. SEE WALL DETAILS ON SHEET WD1. SEE WALL PROFILES ON WP SHEETS.
  - DRIVEWAY REMOVAL. SEE MP SHEETS FOR PLANTING PLAN.
  - INSTALL PATTERNED CONCRETE DRIVEWAY. SEE DETAILS ON SHEET XX.
  - INSTALL TYPE 1 REST STOP. SEE DETAILS ON SHEET XX.
  - INSTALL TYPE 2 REST STOP. SEE DETAILS ON SHEET XX.
  - INSTALL SOLDIER PILE WALL.
  - INSTALL GRAVITY BLOCK WALL.
  - INSTALL WING WALL, SEE FP SHEETS.
  - INSTALL EXTRUDED CURB PER WSDOT STD PLAN F-10.42-00.
  - REST STOP PULL-OUT.
  - STAIRS WILL BE ELIMINATED DURING CONSTRUCTION.
  - BRIDGES WILL BE REMOVED TO R/W LINE DURING CONSTRUCTION.
  - INSTALL ROCK WALL.



**B-LINE PROFILE**  
 HORIZ: 1"=20'  
 VERT: 1"=5'

- STORMWATER CONSTRUCTION NOTES:**
- INFILTRATION TRENCH, SEE DETAIL 4 ON SHEET DD1.
  - UNDERDRAIN TRENCH, SEE DETAIL 5 ON SHEET DD1.
  - ROCK PAD, SEE DETAIL 2 ON SHEET DD1 AND WP SHEETS.
  - CONNECTION TO DRAINAGE STRUCTURE AND CLEANING EXISTING DRAINAGE STRUCTURE.
  - INSTALL UNDERDRAIN TRENCH CLEANOUT, SEE DETAIL 6 ON SHEET DD1.
  - INSTALL RECTANGULAR SLIP RESISTANT SOLID METAL COVER PER WSDOT STD DETAIL B-30.20-02.
  - CONCRETE HEADWALL, SEE DETAIL 1 ON SHEET DD1.
  - BASIC DISPERSION, SEE SHEET CS3.
  - QUARRY SPALL OUTFALL PROTECTION. SEE DETAIL 3 ON SHEET DD1.
  - ADJUST CATCH BASIN.

- LEGEND:**
- RETAINING WALL
  - SOLDIER PILE WALL
  - WOOD GUARDRAIL
  - DISPERSION AREA
  - DRIVEWAY REMOVAL

**CITY OF SAMMAMISH APPROVAL**

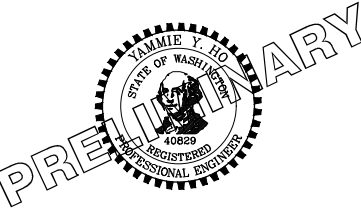
City Engineer _____	Date _____
Community Development _____	Date _____

**60% REVIEW SUBMITTAL**  
 NOT FOR CONSTRUCTION

REVISIONS	DATE	BY	DESIGNED
			M. TSUN
			B. PURGANAN
			P. JOHANNESSEN
			Y. HO

**ONE INCH AT FULL SCALE, IF NOT, SCALE ACCORDINGLY**

FILE NAME: BL1521075P19T03AL-01  
 JOB No: 554-1521-075 P19 T03  
 DATE: SEPTEMBER 2016



**Parametrix**  
 ENGINEERING · PLANNING · ENVIRONMENTAL SCIENCES

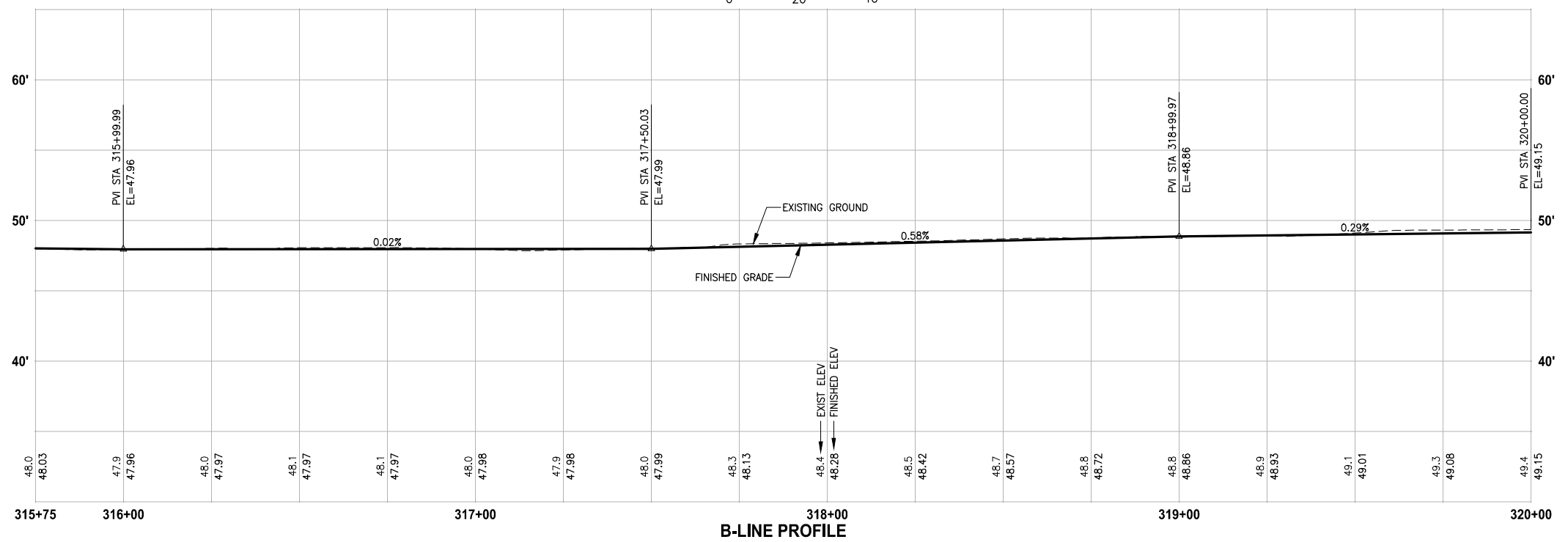
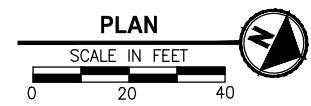
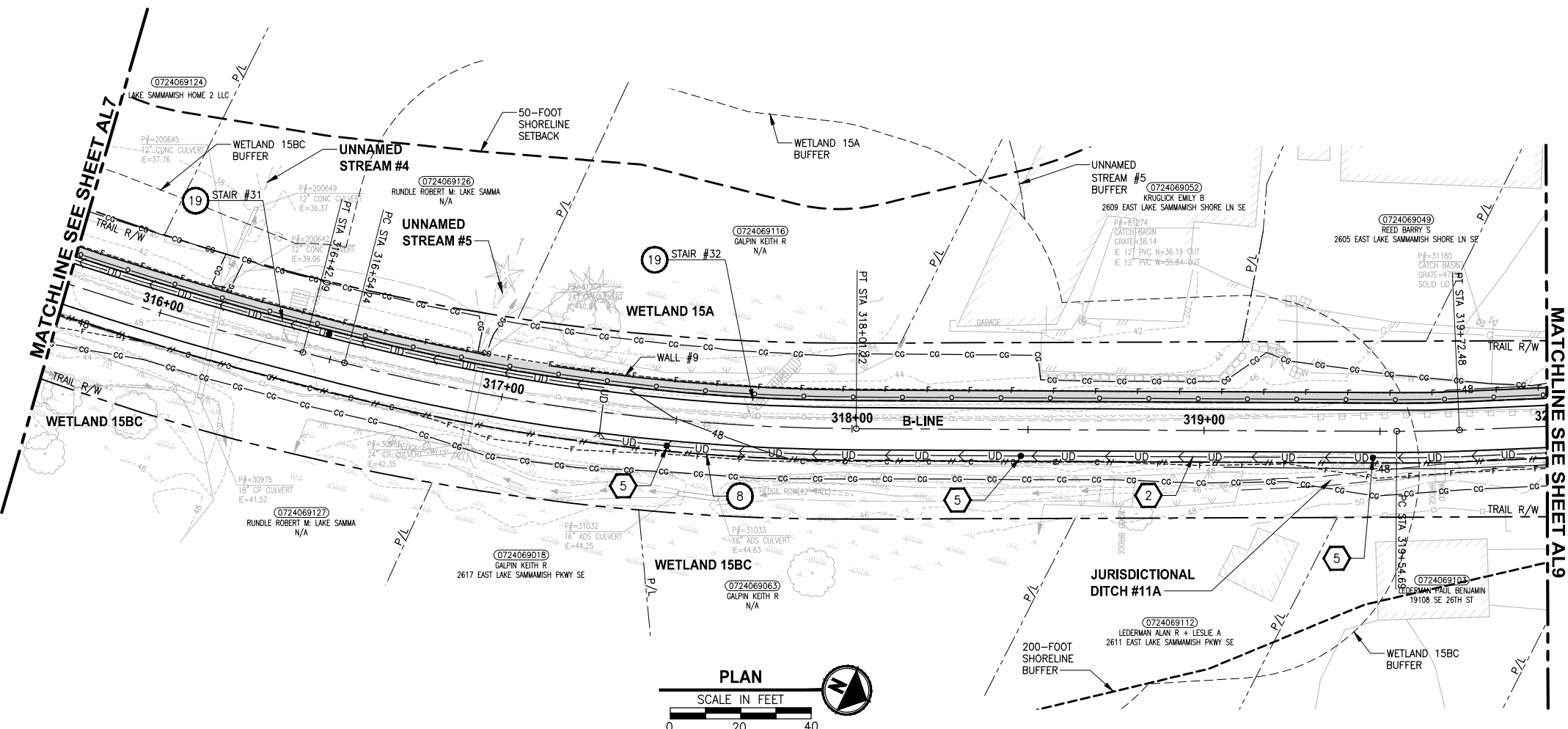
719 2ND AVENUE, SUITE 200 | SEATTLE, WA 98104  
 P 206.394.3700  
 WWW.PARAMETRIX.COM

PROJECT NAME  
**EAST LAKE SAMMAMISH MASTER PLAN TRAIL SOUTH SAMMAMISH SEGMENT B**  
 SAMMAMISH, WA

**PLAN AND PROFILE**

SHEET NO. 39 OF 135  
**AL7**

LAYOUT: ALB  
 PATH: U:\P50\Projects\Clients\1521-KingCo\554-1521-075-ELSA\99Sves\CADD\Phase 19\T03\_Civil\DWG\  
 PLOTTED BY: purgubut DATE: Wednesday, October 12, 2016 8:53:08 PM



**B-LINE PROFILE**  
 HORIZ: 1"=20'  
 VERT: 1"=5'

- CIVIL CONSTRUCTION NOTES:**
- 1 RESTORE AND INSTALL STAIR. TYPE TO BE DETERMINED.
  - 2 RECONSTRUCT PEDESTRIAN BRIDGE.
  - 3 INSTALL PRECAST REINF CONC SPLIT BOX CULVERT. SEE FP SHEETS FOR DETAILS.
  - 4 INSTALL STRUCTURAL EARTH WALL. SEE WALL DETAILS ON SHEET X. SEE WALL PROFILES ON WP SHEETS.
  - 5 INSTALL COATED CHAIN LINK FENCE TYPE 6. FOR GROUND POST INSTALLATION SEE APPENDIX B IN THE SPECIFICATIONS. SEE SHEET X FOR MOUNTING ON TOP OF WALL.
  - 6 NEW DRIVEWAY.
  - 7 INSTALL WOOD GUARDRAIL, SEE DETAILS ON SHEET XX.
  - 8 INSTALL SPLIT RAIL FENCE, SEE DETAILS ON SHEET XX.
  - 9 INSTALL GRAVITY BLOCK WALL. SEE WALL DETAILS ON SHEET WD1. SEE WALL PROFILES ON WP SHEETS.
  - 10 DRIVEWAY REMOVAL. SEE MP SHEETS FOR PLANTING PLAN.
  - 11 INSTALL PATTERNED CONCRETE DRIVEWAY. SEE DETAILS ON SHEET XX.
  - 12 INSTALL TYPE 1 REST STOP. SEE DETAILS ON SHEET XX.
  - 13 INSTALL TYPE 2 REST STOP. SEE DETAILS ON SHEET XX.
  - 14 INSTALL SOLDIER PILE WALL.
  - 15 INSTALL GRAVITY BLOCK WALL.
  - 16 INSTALL WING WALL, SEE FP SHEETS.
  - 17 INSTALL EXTRUDED CURB PER WSDOT STD PLAN F-10.42-00.
  - 18 REST STOP PULL-OUT.
  - 19 STAIRS WILL BE ELIMINATED DURING CONSTRUCTION.
  - 20 BRIDGES WILL BE REMOVED TO R/W LINE DURING CONSTRUCTION.
  - 21 INSTALL ROCK WALL.

- STORMWATER CONSTRUCTION NOTES:**
- 1 INFILTRATION TRENCH, SEE DETAIL 4 ON SHEET DD1.
  - 2 UNDERDRAIN TRENCH, SEE DETAIL 5 ON SHEET DD1.
  - 3 ROCK PAD, SEE DETAIL 2 ON SHEET DD1 AND WP SHEETS.
  - 4 CONNECTION TO DRAINAGE STRUCTURE AND CLEANING EXISTING DRAINAGE STRUCTURE.
  - 5 INSTALL UNDERDRAIN TRENCH CLEANOUT, SEE DETAIL 6 ON SHEET DD1.
  - 6 INSTALL RECTANGULAR SLIP RESISTANT SOLID METAL COVER PER WSDOT STD DETAIL B-30.20-02.
  - 7 CONCRETE HEADWALL, SEE DETAIL 1 ON SHEET DD1.
  - 8 BASIC DISPERSION, SEE SHEET CS3.
  - 9 QUARRY SPALL OUTFALL PROTECTION. SEE DETAIL 3 ON SHEET DD1.
  - 10 ADJUST CATCH BASIN.

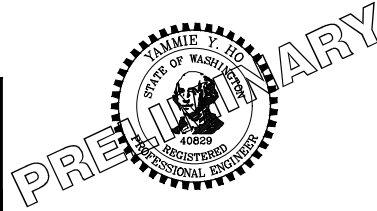
- LEGEND:**
- RETAINING WALL
  - SOLDIER PILE WALL
  - WOOD GUARDRAIL
  - DISPERSION AREA
  - DRIVEWAY REMOVAL

CITY OF SAMMAMISH APPROVAL	
City Engineer _____	Date _____
Community Development _____	Date _____

**60 % REVIEW SUBMITTAL**  
 NOT FOR CONSTRUCTION

REVISIONS	DATE	BY	DESIGNED
			M. TSUN
			B. PURGANAN
			P. JOHANNESSEN
			Y. HO

ONE INCH AT FULL SCALE.  
 IF NOT, SCALE ACCORDINGLY  
 FILE NAME: BL1521075P19T03AL-01  
 JOB No.: 554-1521-075 P19 T03  
 DATE: SEPTEMBER 2016



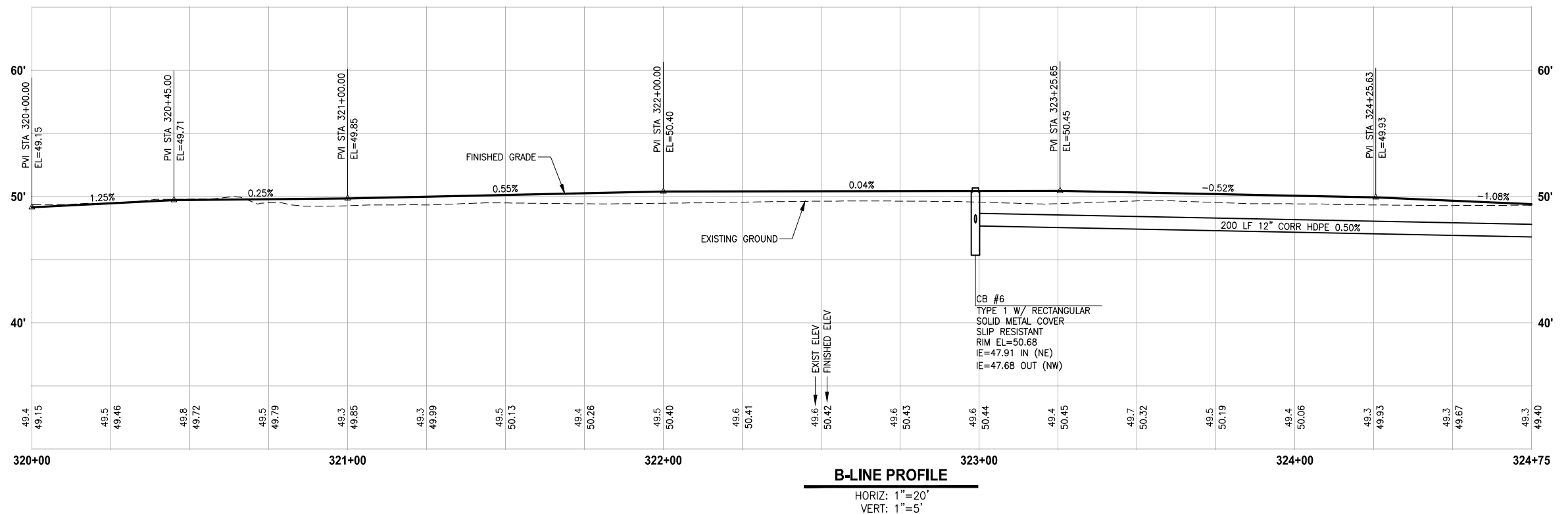
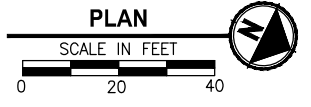
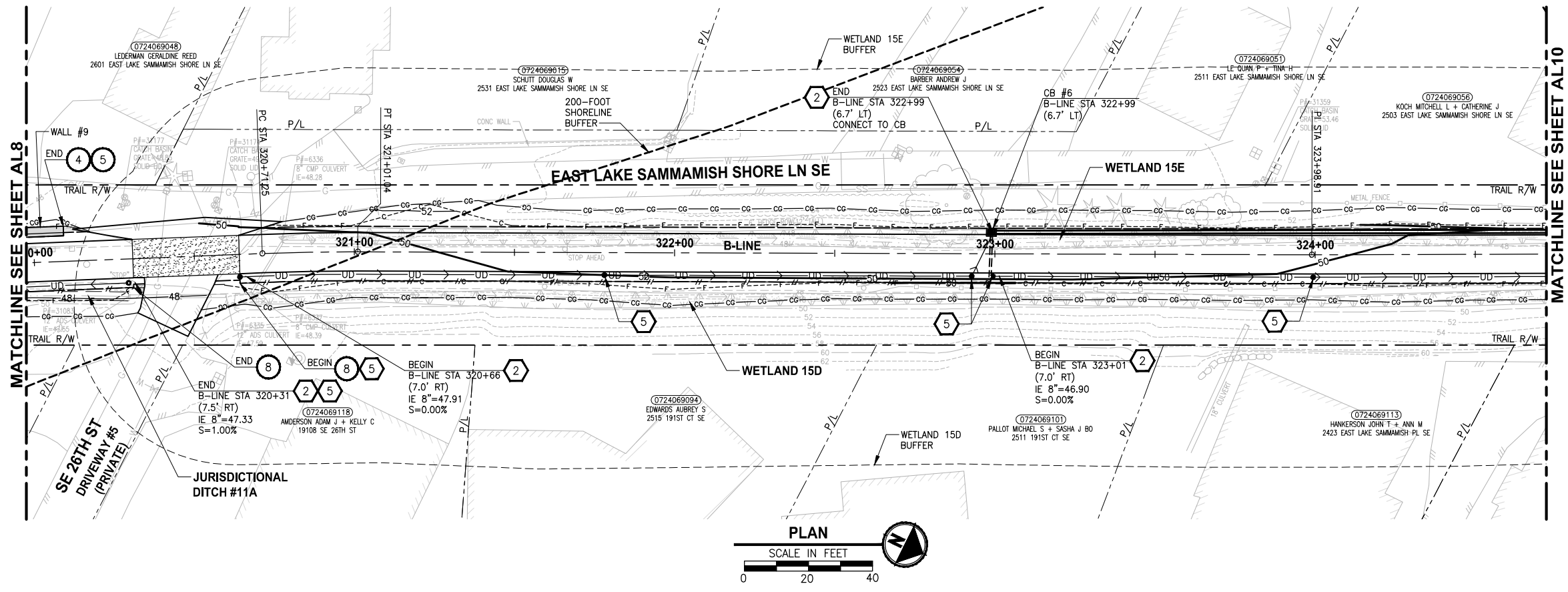
**Parametrix**  
 ENGINEERING · PLANNING · ENVIRONMENTAL SCIENCES  
 719 2ND AVENUE, SUITE 200 | SEATTLE, WA 98104  
 P 206.394.3700  
 WWW.PARAMETRIX.COM

PROJECT NAME  
**EAST LAKE SAMMAMISH  
 MASTER PLAN TRAIL  
 SOUTH SAMMAMISH SEGMENT B**  
 SAMMAMISH, WA

**PLAN AND PROFILE**

SHEET NO.  
 40 OF 135  
**AL8**

PATH: U:\P50\Projects\Clients\1521-075-ELST\99Secs\CADD\Phase 19\T03\_Civil\DWG\ PLOTTED BY: purgaban DATE: Wednesday, October 12, 2016 8:53:39 PM LAYOUT: AL9



- CIVIL CONSTRUCTION NOTES:**
- 1 RESTORE AND INSTALL STAIR. TYPE TO BE DETERMINED.
  - 2 RECONSTRUCT PEDESTRIAN BRIDGE.
  - 3 INSTALL PRECAST REINF CONC SPLIT BOX CULVERT. SEE FP SHEETS FOR DETAILS.
  - 4 INSTALL STRUCTURAL EARTH WALL. SEE WALL DETAILS ON SHEET X. SEE WALL PROFILES ON WP SHEETS.
  - 5 INSTALL COATED CHAIN LINK FENCE TYPE 6. FOR GROUND POST INSTALLATION SEE APPENDIX B IN THE SPECIFICATIONS. SEE SHEET X FOR MOUNTING ON TOP OF WALL.
  - 6 NEW DRIVEWAY.
  - 7 INSTALL WOOD GUARDRAIL, SEE DETAILS ON SHEET XX.
  - 8 INSTALL SPLIT RAIL FENCE, SEE DETAILS ON SHEET XX.
  - 9 INSTALL GRAVITY BLOCK WALL. SEE WALL DETAILS ON SHEET WD1. SEE WALL PROFILES ON WP SHEETS.
  - 10 DRIVEWAY REMOVAL. SEE MP SHEETS FOR PLANTING PLAN.
  - 11 INSTALL PATTERNED CONCRETE DRIVEWAY. SEE DETAILS ON SHEET XX.
  - 12 INSTALL TYPE 1 REST STOP. SEE DETAILS ON SHEET XX.
  - 13 INSTALL TYPE 2 REST STOP. SEE DETAILS ON SHEET XX.
  - 14 INSTALL SOLDIER PILE WALL.
  - 15 INSTALL GRAVITY BLOCK WALL.
  - 16 INSTALL WING WALL, SEE FP SHEETS.
  - 17 INSTALL EXTRUDED CURB PER WSDOT STD PLAN F-10.42-00.
  - 18 REST STOP PULL-OUT.
  - 19 STAIRS WILL BE ELIMINATED DURING CONSTRUCTION.
  - 20 BRIDGES WILL BE REMOVED TO R/W LINE DURING CONSTRUCTION.
  - 21 INSTALL ROCK WALL.

- STORMWATER CONSTRUCTION NOTES:**
- 1 INFILTRATION TRENCH, SEE DETAIL 4 ON SHEET DD1.
  - 2 UNDERDRAIN TRENCH, SEE DETAIL 5 ON SHEET DD1.
  - 3 ROCK PAD, SEE DETAIL 2 ON SHEET DD1 AND WP SHEETS.
  - 4 CONNECTION TO DRAINAGE STRUCTURE AND CLEANING EXISTING DRAINAGE STRUCTURE.
  - 5 INSTALL UNDERDRAIN TRENCH CLEANOUT, SEE DETAIL 6 ON SHEET DD1.
  - 6 INSTALL RECTANGULAR SLIP RESISTANT SOLID METAL COVER PER WSDOT STD DETAIL B-30.20-02.
  - 7 CONCRETE HEADWALL, SEE DETAIL 1 ON SHEET DD1.
  - 8 BASIC DISPERSION, SEE SHEET CS3.
  - 9 QUARRY SPALL OUTFALL PROTECTION. SEE DETAIL 3 ON SHEET DD1.
  - 10 ADJUST CATCH BASIN.

- LEGEND:**
- RETAINING WALL
  - SOLDIER PILE WALL
  - WOOD GUARDRAIL
  - DISPERSION AREA
  - DRIVEWAY REMOVAL

**CITY OF SAMMAMISH APPROVAL**

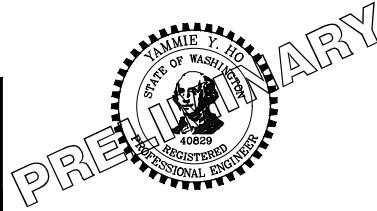
City Engineer _____	Date _____
Community Development _____	Date _____

**60 % REVIEW SUBMITTAL  
NOT FOR CONSTRUCTION**

REVISIONS	DATE	BY	DESIGNED
			M. TSUN
			B. PURGANAN
			P. JOHANNESSEN
			Y. HO

**ONE INCH AT FULL SCALE, IF NOT, SCALE ACCORDINGLY**

FILE NAME: BL1521075P19T03AL-01  
 JOB No: 554-1521-075 P19 T03  
 DATE: SEPTEMBER 2016



**Parametrix**  
 ENGINEERING · PLANNING · ENVIRONMENTAL SCIENCES

719 2ND AVENUE, SUITE 200 | SEATTLE, WA 98104  
 P 206.394.3700  
 WWW.PARAMETRIX.COM

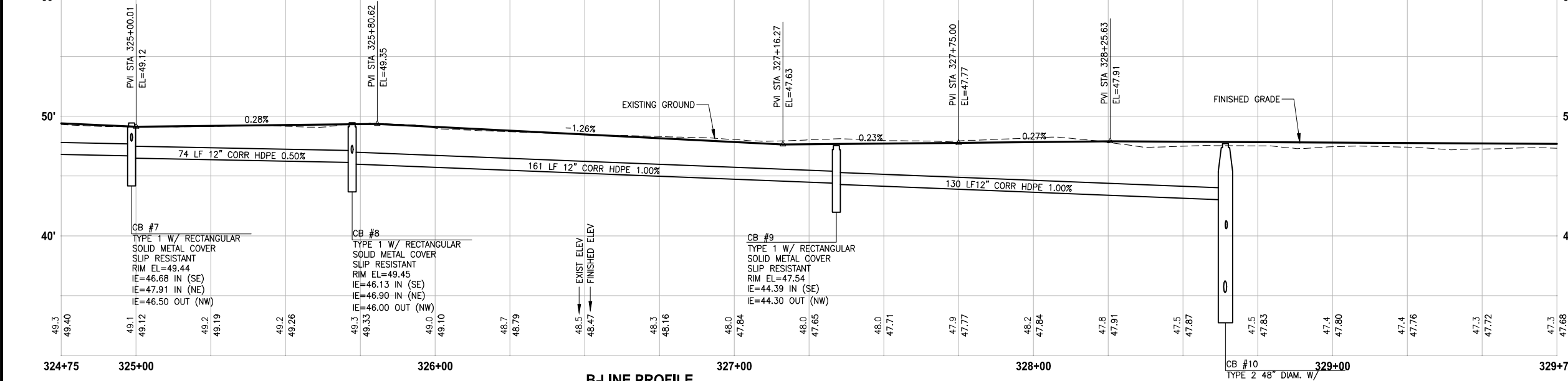
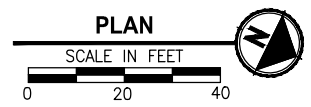
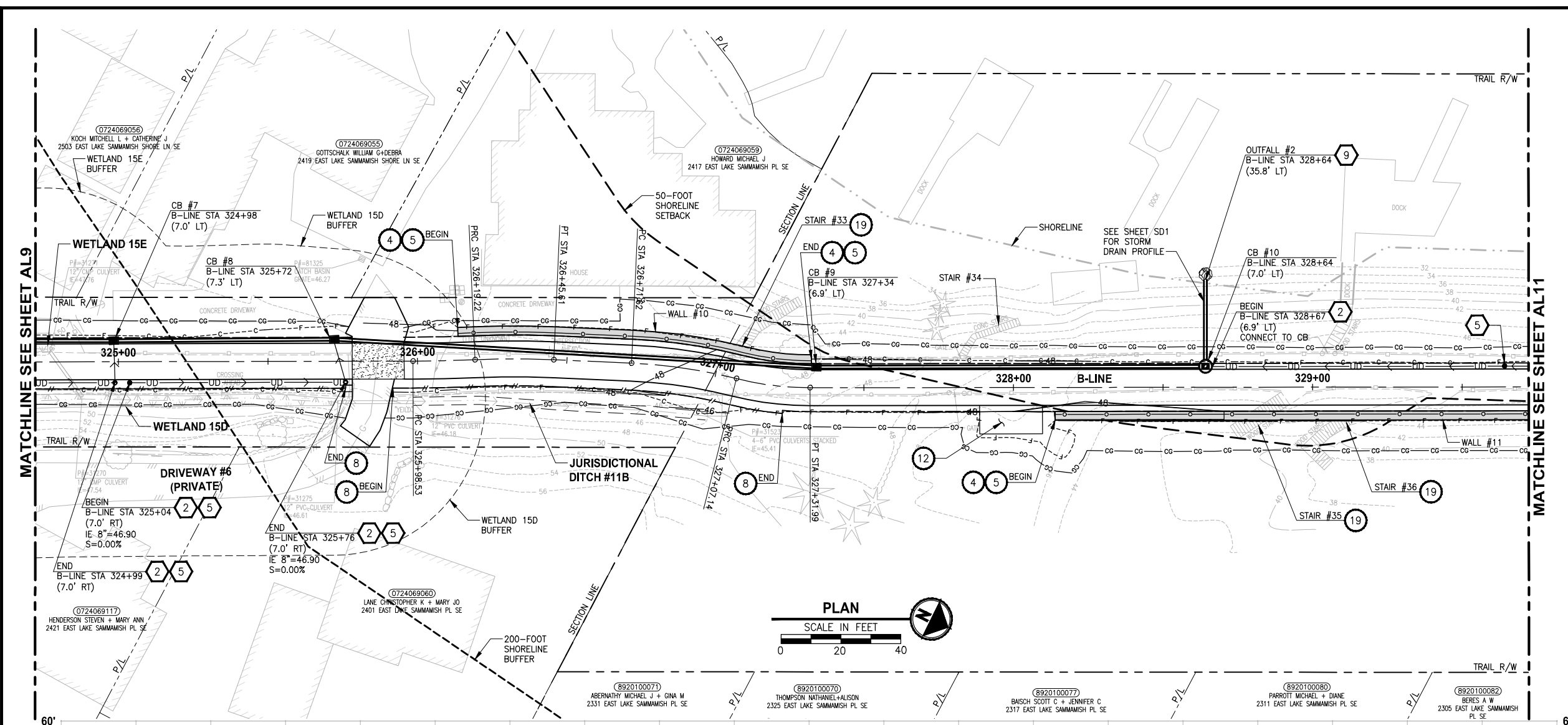
PROJECT NAME  
**EAST LAKE SAMMAMISH  
 MASTER PLAN TRAIL  
 SOUTH SAMMAMISH SEGMENT B**  
 SAMMAMISH, WA

**PLAN AND PROFILE**

SHEET NO.  
 41 OF 135  
**AL9**



LAYOUT: AL10  
 PATH: U:\PSO\Projects\Clients\1521-KingCo\1521-075-ELST\995\Drawings\19\_T03\_Civil\DWG\...  
 PLOTTED BY: purgabul DATE: Wednesday, October 12, 2016 8:54:10 PM



- CIVIL CONSTRUCTION NOTES:**
- 1 RESTORE AND INSTALL STAIR. TYPE TO BE DETERMINED.
  - 2 RECONSTRUCT PEDESTRIAN BRIDGE.
  - 3 INSTALL PRECAST REINF CONC SPLIT BOX CULVERT. SEE FP SHEETS FOR DETAILS.
  - 4 INSTALL STRUCTURAL EARTH WALL. SEE WALL DETAILS ON SHEET X. SEE WALL PROFILES ON WP SHEETS.
  - 5 INSTALL COATED CHAIN LINK FENCE TYPE 6. FOR GROUND POST INSTALLATION SEE APPENDIX B IN THE SPECIFICATIONS. SEE SHEET X FOR MOUNTING ON TOP OF WALL.
  - 6 NEW DRIVEWAY.
  - 7 INSTALL WOOD GUARDRAIL, SEE DETAILS ON SHEET XX.
  - 8 INSTALL SPLIT RAIL FENCE, SEE DETAILS ON SHEET XX.
  - 9 INSTALL GRAVITY BLOCK WALL. SEE WALL DETAILS ON SHEET WD1. SEE WALL PROFILES ON WP SHEETS.
  - 10 DRIVEWAY REMOVAL. SEE MP SHEETS FOR PLANTING PLAN.
  - 11 INSTALL PATTERNED CONCRETE DRIVEWAY. SEE DETAILS ON SHEET XX.
  - 12 INSTALL TYPE 1 REST STOP. SEE DETAILS ON SHEET XX.
  - 13 INSTALL TYPE 2 REST STOP. SEE DETAILS ON SHEET XX.
  - 14 INSTALL SOLDIER PILE WALL.
  - 15 INSTALL GRAVITY BLOCK WALL.
  - 16 INSTALL WING WALL, SEE FP SHEETS.
  - 17 INSTALL EXTRUDED CURB PER WSDOT STD PLAN F-10.42-00.
  - 18 REST STOP PULL-OUT.
  - 19 STAIRS WILL BE ELIMINATED DURING CONSTRUCTION.
  - 20 BRIDGES WILL BE REMOVED TO R/W LINE DURING CONSTRUCTION.
  - 21 INSTALL ROCK WALL.

- STORMWATER CONSTRUCTION NOTES:**
- 1 INFILTRATION TRENCH, SEE DETAIL 4 ON SHEET DD1.
  - 2 UNDERDRAIN TRENCH, SEE DETAIL 5 ON SHEET DD1.
  - 3 ROCK PAD, SEE DETAIL 2 ON SHEET DD1 AND WP SHEETS.
  - 4 CONNECTION TO DRAINAGE STRUCTURE AND CLEANING EXISTING DRAINAGE STRUCTURE.
  - 5 INSTALL UNDERDRAIN TRENCH CLEANOUT, SEE DETAIL 6 ON SHEET DD1.
  - 6 INSTALL RECTANGULAR SLIP RESISTANT SOLID METAL COVER PER WSDOT STD DETAIL B-30.20-02.
  - 7 CONCRETE HEADWALL, SEE DETAIL 1 ON SHEET DD1.
  - 8 BASIC DISPERSION, SEE SHEET CS3.
  - 9 QUARRY SPALL OUTFALL PROTECTION. SEE DETAIL 3 ON SHEET DD1.
  - 10 ADJUST CATCH BASIN.

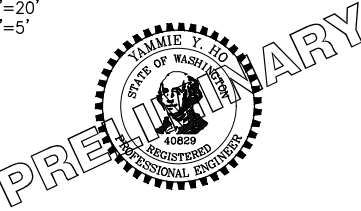
- LEGEND:**
- RETAINING WALL
  - SOLDIER PILE WALL
  - WOOD GUARDRAIL
  - DISPERSION AREA
  - DRIVEWAY REMOVAL

CITY OF SAMMAMISH APPROVAL	
City Engineer _____	Date _____
Community Development _____	Date _____

**60% REVIEW SUBMITTAL  
NOT FOR CONSTRUCTION**

NO.	REVISIONS	DATE	BY	DESIGNED
				M. TSUN
				B. PURGANAN
				P. JOHANNESSEN
				Y. HO

**ONE INCH AT FULL SCALE,  
IF NOT, SCALE ACCORDINGLY**  
 FILE NAME: BL1521075P19T03AL-01  
 JOB No: 554-1521-075 P19 T03  
 DATE: SEPTEMBER 2016



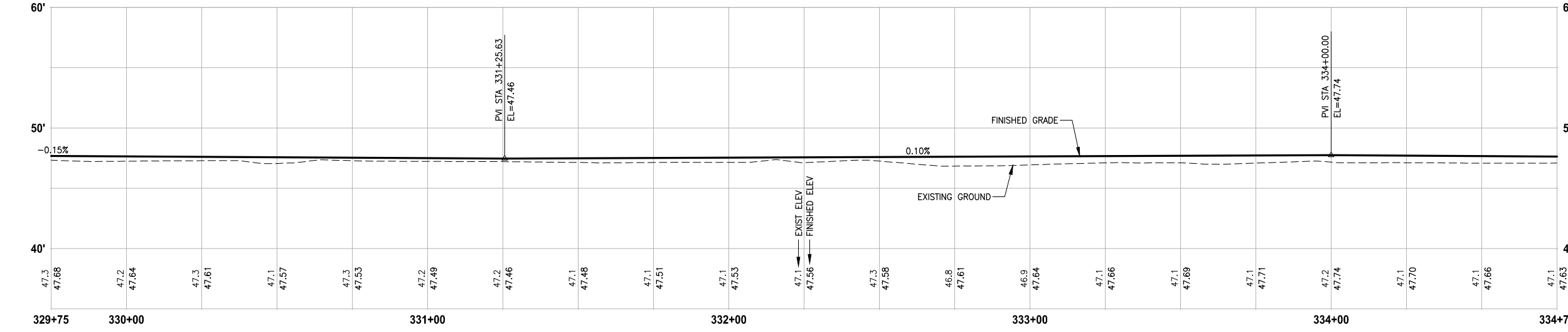
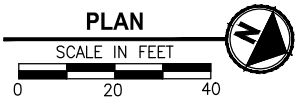
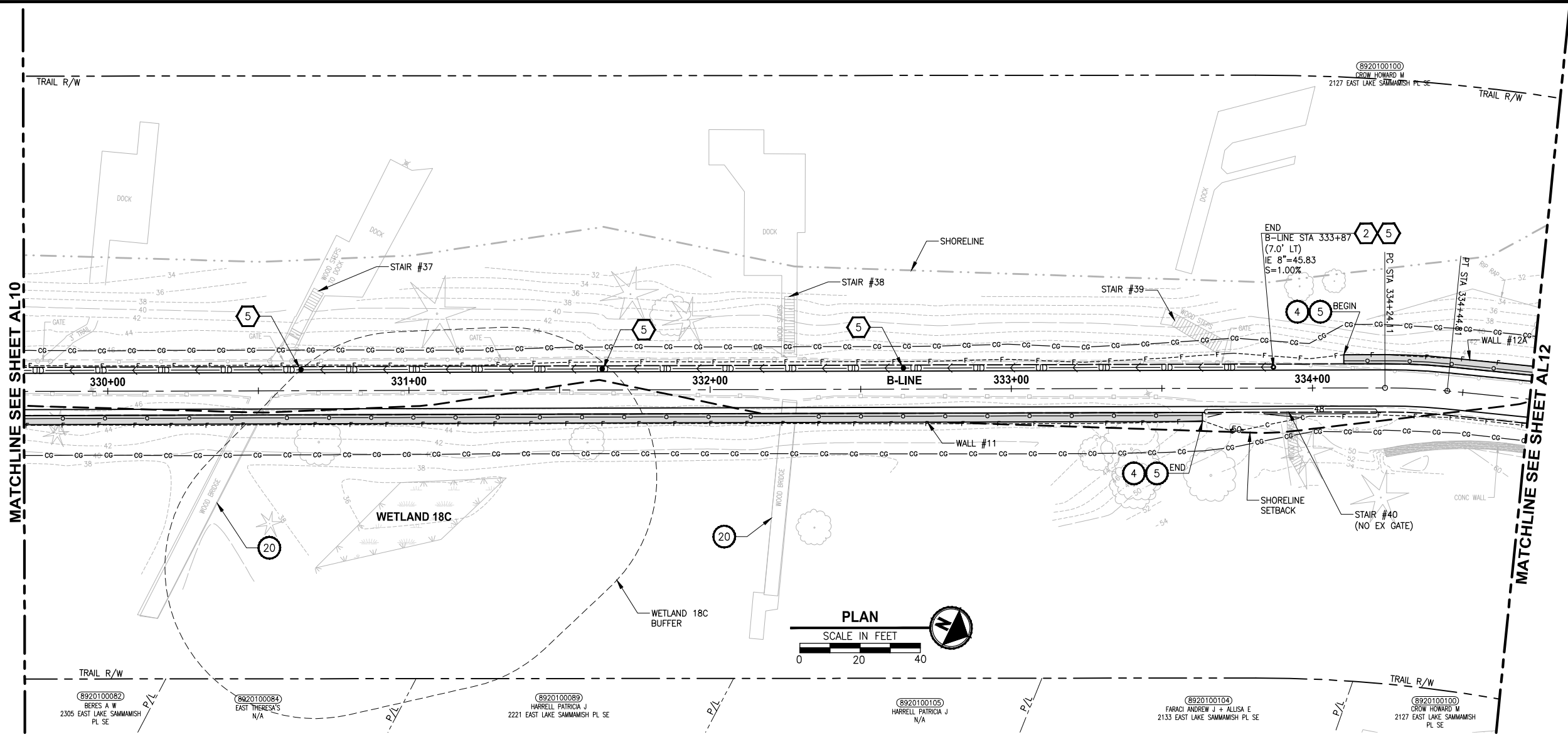
**Parametrix**  
 ENGINEERING · PLANNING · ENVIRONMENTAL SCIENCES  
 719 2ND AVENUE, SUITE 200 | SEATTLE, WA 98104  
 P 206.394.3700  
 WWW.PARAMETRIX.COM

PROJECT NAME  
**EAST LAKE SAMMAMISH  
MASTER PLAN TRAIL  
SOUTH SAMMAMISH SEGMENT B**  
 SAMMAMISH, WA

**PLAN AND PROFILE**

SHEET NO.  
 42 OF 135  
**AL10**

PATH: U:\PSO\Projects\Clients\KingCo\564-1521-075-ELST\99Svcs\CADD\Phase 19\T03\_Civil\DWG\ PLOTTED BY: purganub DATE: Wednesday, October 12, 2016 8:58:05 PM LAYOUT: AL11



**B-LINE PROFILE**  
 HORIZ: 1"=20'  
 VERT: 1"=5'

- CIVIL CONSTRUCTION NOTES:**
- 1 RESTORE AND INSTALL STAIR. TYPE TO BE DETERMINED.
  - 2 RECONSTRUCT PEDESTRIAN BRIDGE.
  - 3 INSTALL PRECAST REINF CONC SPLIT BOX CULVERT. SEE FP SHEETS FOR DETAILS.
  - 4 INSTALL STRUCTURAL EARTH WALL. SEE WALL DETAILS ON SHEET X. SEE WALL PROFILES ON WP SHEETS.
  - 5 INSTALL COATED CHAIN LINK FENCE TYPE 6. FOR GROUND POST INSTALLATION SEE APPENDIX B IN THE SPECIFICATIONS. SEE SHEET X FOR MOUNTING ON TOP OF WALL.
  - 6 NEW DRIVEWAY.
  - 7 INSTALL WOOD GUARDRAIL, SEE DETAILS ON SHEET XX.
  - 8 INSTALL SPLIT RAIL FENCE, SEE DETAILS ON SHEET XX.
  - 9 INSTALL GRAVITY BLOCK WALL. SEE WALL DETAILS ON SHEET WD1. SEE WALL PROFILES ON WP SHEETS.
  - 10 DRIVEWAY REMOVAL. SEE MP SHEETS FOR PLANTING PLAN.
  - 11 INSTALL PATTERNED CONCRETE DRIVEWAY. SEE DETAILS ON SHEET XX.
  - 12 INSTALL TYPE 1 REST STOP. SEE DETAILS ON SHEET XX.
  - 13 INSTALL TYPE 2 REST STOP. SEE DETAILS ON SHEET XX.
  - 14 INSTALL SOLDIER PILE WALL.
  - 15 INSTALL GRAVITY BLOCK WALL.
  - 16 INSTALL WING WALL, SEE FP SHEETS.
  - 17 INSTALL EXTRUDED CURB PER WSDOT STD PLAN F-10.42-00.
  - 18 REST STOP PULL-OUT.
  - 19 STAIRS WILL BE ELIMINATED DURING CONSTRUCTION.
  - 20 BRIDGES WILL BE REMOVED TO R/W LINE DURING CONSTRUCTION.
  - 21 INSTALL ROCK WALL.

- STORMWATER CONSTRUCTION NOTES:**
- 1 INFILTRATION TRENCH, SEE DETAIL 4 ON SHEET DD1.
  - 2 UNDERDRAIN TRENCH, SEE DETAIL 5 ON SHEET DD1.
  - 3 ROCK PAD, SEE DETAIL 2 ON SHEET DD1 AND WP SHEETS.
  - 4 CONNECTION TO DRAINAGE STRUCTURE AND CLEANING EXISTING DRAINAGE STRUCTURE.
  - 5 INSTALL UNDERDRAIN TRENCH CLEANOUT, SEE DETAIL 6 ON SHEET DD1.
  - 6 INSTALL RECTANGULAR SLIP RESISTANT SOLID METAL COVER PER WSDOT STD DETAIL B-30.20-02.
  - 7 CONCRETE HEADWALL, SEE DETAIL 1 ON SHEET DD1.
  - 8 BASIC DISPERSION, SEE SHEET CS3.
  - 9 QUARRY SPALL OUTFALL PROTECTION. SEE DETAIL 3 ON SHEET DD1.
  - 10 ADJUST CATCH BASIN.

- LEGEND:**
- RETAINING WALL
  - SOLDIER PILE WALL
  - WOOD GUARDRAIL
  - DISPERSION AREA
  - DRIVEWAY REMOVAL

**CITY OF SAMMAMISH APPROVAL**

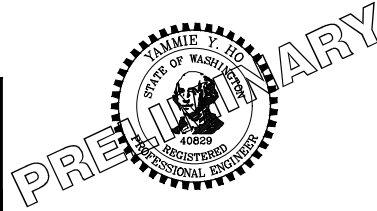
City Engineer _____	Date _____
Community Development _____	Date _____

**60 % REVIEW SUBMITTAL**  
 NOT FOR CONSTRUCTION

REVISIONS	DATE	BY	DESIGNED
			M. TSUN
			B. PURGANAN
			P. JOHANNESSEN
			Y. HO

**ONE INCH AT FULL SCALE, IF NOT, SCALE ACCORDINGLY**

FILE NAME: BL1521075P19T03AL-02  
 JOB No: 564-1521-075 P19 T03  
 DATE: SEPTEMBER 2016



**Parametrix**  
 ENGINEERING · PLANNING · ENVIRONMENTAL SCIENCES

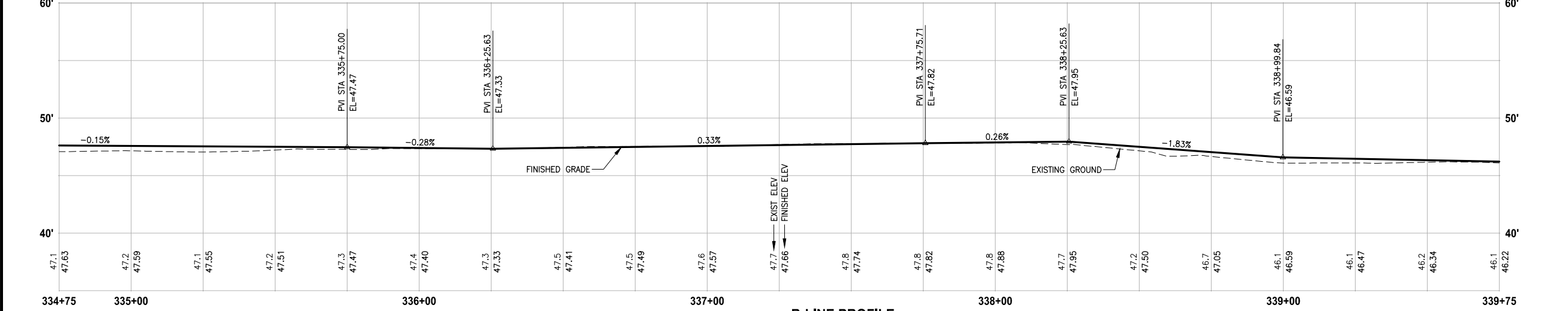
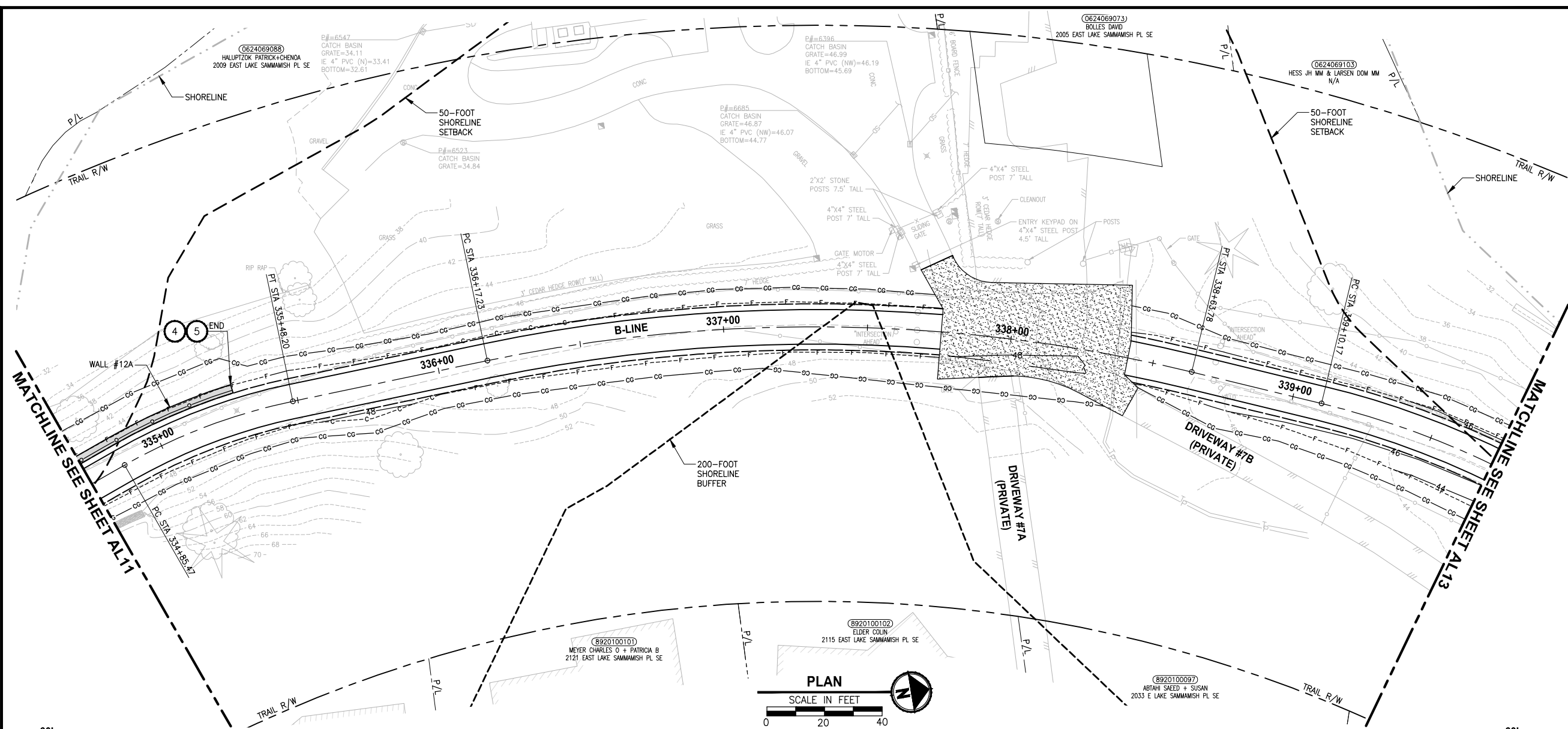
719 2ND AVENUE, SUITE 200 | SEATTLE, WA 98104  
 P 206.394.3700  
 WWW.PARAMETRIX.COM

PROJECT NAME  
**EAST LAKE SAMMAMISH MASTER PLAN TRAIL SOUTH SAMMAMISH SEGMENT B**  
 SAMMAMISH, WA

**PLAN AND PROFILE**

SHEET NO.  
 43 OF 135  
**AL11**

LAYOUT: AL12  
 PATH: U:\PSO\Projects\Clients\1521-KingCo\554-1521-075-ELST\995\cadd\Phase 19\T03\_Civil\DWG\  
 PLOTTED BY: purgaban DATE: Wednesday, October 12, 2016 8:58:33 PM



- CIVIL CONSTRUCTION NOTES:**
- RESTORE AND INSTALL STAIR. TYPE TO BE DETERMINED.
  - RECONSTRUCT PEDESTRIAN BRIDGE.
  - INSTALL PRECAST REINF CONC SPLIT BOX CULVERT. SEE FP SHEETS FOR DETAILS.
  - INSTALL STRUCTURAL EARTH WALL. SEE WALL DETAILS ON SHEET X. SEE WALL PROFILES ON WP SHEETS.
  - INSTALL COATED CHAIN LINK FENCE TYPE 6. FOR GROUND POST INSTALLATION SEE APPENDIX B IN THE SPECIFICATIONS. SEE SHEET X FOR MOUNTING ON TOP OF WALL.
  - NEW DRIVEWAY.
  - INSTALL WOOD GUARDRAIL, SEE DETAILS ON SHEET XX.
  - INSTALL SPLIT RAIL FENCE, SEE DETAILS ON SHEET XX.
  - INSTALL GRAVITY BLOCK WALL. SEE WALL DETAILS ON SHEET WD1. SEE WALL PROFILES ON WP SHEETS.
  - DRIVEWAY REMOVAL. SEE MP SHEETS FOR PLANTING PLAN.
  - INSTALL PATTERNED CONCRETE DRIVEWAY. SEE DETAILS ON SHEET XX.
  - INSTALL TYPE 1 REST STOP. SEE DETAILS ON SHEET XX.
  - INSTALL TYPE 2 REST STOP. SEE DETAILS ON SHEET XX.
  - INSTALL SOLDIER PILE WALL.
  - INSTALL GRAVITY BLOCK WALL.
  - INSTALL WING WALL, SEE FP SHEETS.
  - INSTALL EXTRUDED CURB PER WSDOT STD PLAN F-10.42-00.
  - REST STOP PULL-OUT.
  - STAIRS WILL BE ELIMINATED DURING CONSTRUCTION.
  - BRIDGES WILL BE REMOVED TO R/W LINE DURING CONSTRUCTION.
  - INSTALL ROCK WALL.

- STORMWATER CONSTRUCTION NOTES:**
- INFILTRATION TRENCH, SEE DETAIL 4 ON SHEET DD1.
  - UNDERDRAIN TRENCH, SEE DETAIL 5 ON SHEET DD1.
  - ROCK PAD, SEE DETAIL 2 ON SHEET DD1 AND WP SHEETS.
  - CONNECTION TO DRAINAGE STRUCTURE AND CLEANING EXISTING DRAINAGE STRUCTURE.
  - INSTALL UNDERDRAIN TRENCH CLEANOUT, SEE DETAIL 6 ON SHEET DD1.
  - INSTALL RECTANGULAR SLIP RESISTANT SOLID METAL COVER PER WSDOT STD DETAIL B-30.20-02.
  - CONCRETE HEADWALL, SEE DETAIL 1 ON SHEET DD1.
  - BASIC DISPERSION, SEE SHEET CS3.
  - QUARRY SPALL OUTFALL PROTECTION. SEE DETAIL 3 ON SHEET DD1.
  - ADJUST CATCH BASIN.

- LEGEND:**
- RETAINING WALL
  - SOLDIER PILE WALL
  - WOOD GUARDRAIL
  - DISPERSION AREA
  - DRIVEWAY REMOVAL

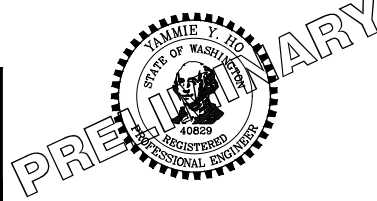
**CITY OF SAMMAMISH APPROVAL**

City Engineer	Date
Community Development	Date

**60% REVIEW SUBMITTAL**  
NOT FOR CONSTRUCTION

REVISIONS	DATE	BY	DESIGNED
			M. TSUN
			B. PURGANAN
			P. JOHANNESSEN
			Y. HO

**ONE INCH AT FULL SCALE, IF NOT, SCALE ACCORDINGLY**  
 FILE NAME: BL1521075P19T03AL-02  
 JOB No.: 554-1521-075 P19 T03  
 DATE: SEPTEMBER 2016



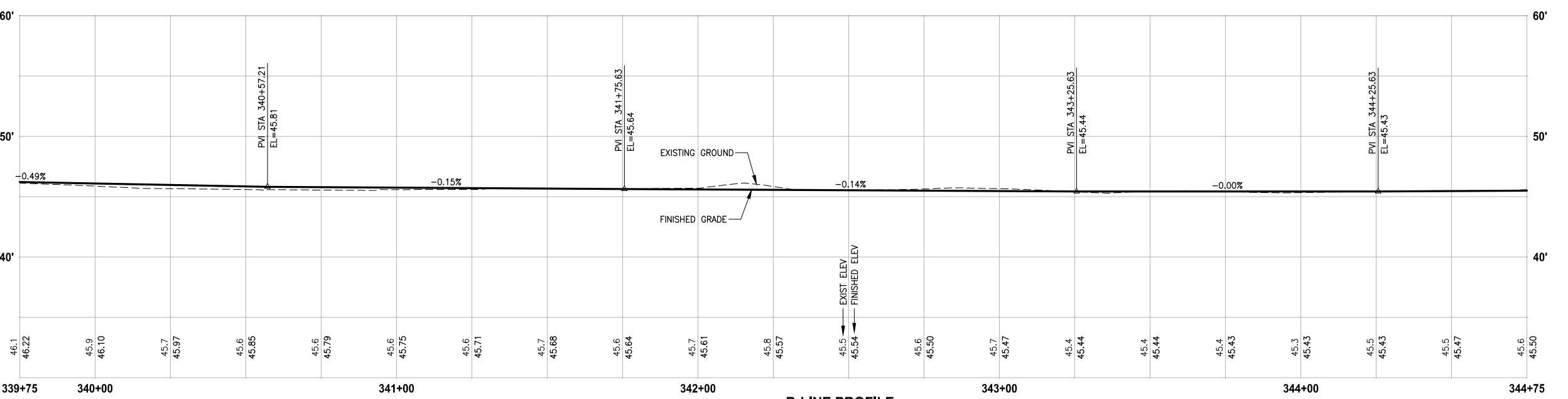
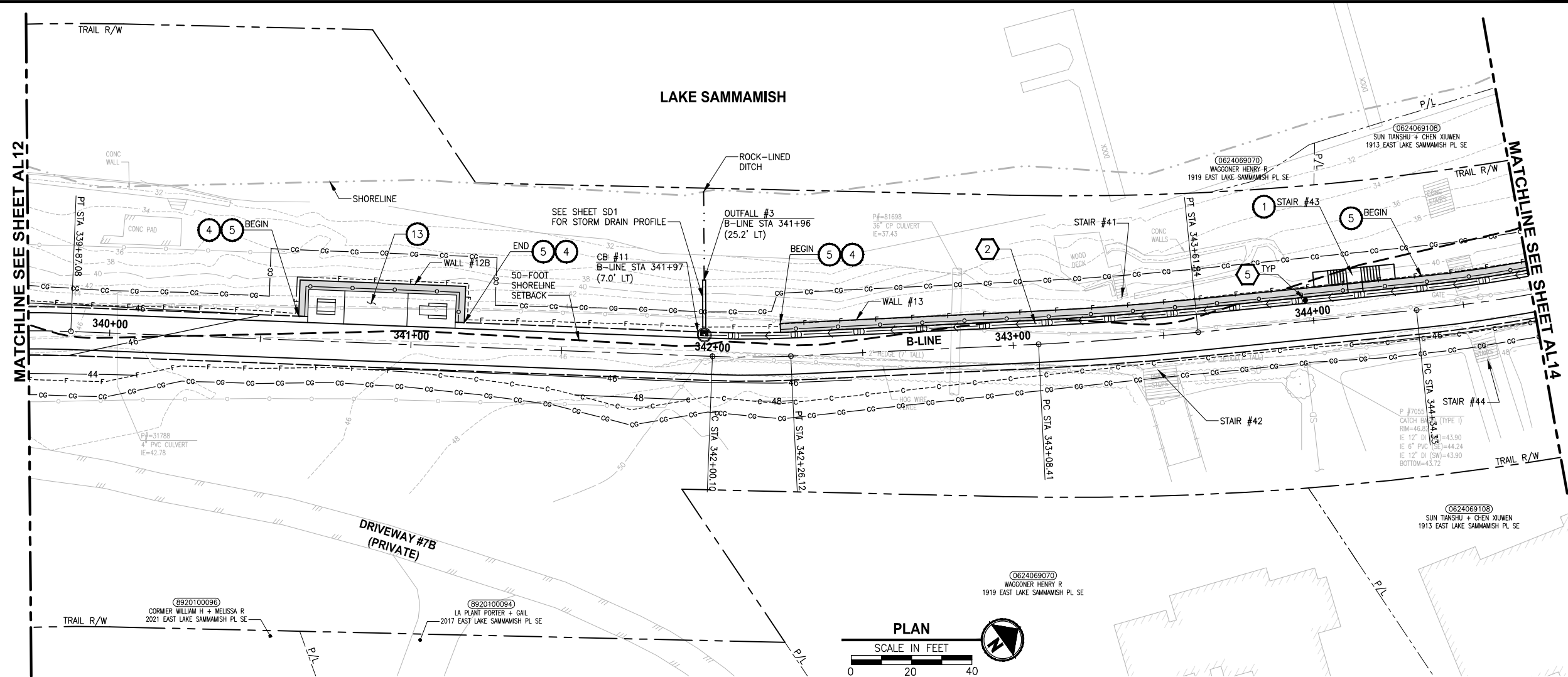
**Parametrix**  
 ENGINEERING · PLANNING · ENVIRONMENTAL SCIENCES  
 719 2ND AVENUE, SUITE 200 | SEATTLE, WA 98104  
 P 206.394.3700  
 WWW.PARAMETRIX.COM

PROJECT NAME  
**EAST LAKE SAMMAMISH MASTER PLAN TRAIL SOUTH SAMMAMISH SEGMENT B**  
 SAMMAMISH, WA

**PLAN AND PROFILE**  
 SHEET NO. 44 OF 135  
**AL12**



LAYOUT: AL13  
 PATH: U:\PSO\Projects\Clients\1521-KingCo\1521-075-ELST\995\Drawings\19\T03\_Civil\DWG\ PLOTTED BY: purganub DATE: Wednesday, October 12, 2016 8:59:05 PM



**B-LINE PROFILE**  
 HORIZ: 1"=20'  
 VERT: 1"=5'

- CIVIL CONSTRUCTION NOTES:**
- 1 RESTORE AND INSTALL STAIR. TYPE TO BE DETERMINED.
  - 2 RECONSTRUCT PEDESTRIAN BRIDGE.
  - 3 INSTALL PRECAST REINF CONC SPLIT BOX CULVERT. SEE FP SHEETS FOR DETAILS.
  - 4 INSTALL STRUCTURAL EARTH WALL. SEE WALL DETAILS ON SHEET X. SEE WALL PROFILES ON WP SHEETS.
  - 5 INSTALL COATED CHAIN LINK FENCE TYPE 6. FOR GROUND POST INSTALLATION SEE APPENDIX B IN THE SPECIFICATIONS. SEE SHEET X FOR MOUNTING ON TOP OF WALL.
  - 6 NEW DRIVEWAY.
  - 7 INSTALL WOOD GUARDRAIL, SEE DETAILS ON SHEET XX.
  - 8 INSTALL SPLIT RAIL FENCE, SEE DETAILS ON SHEET XX.
  - 9 INSTALL GRAVITY BLOCK WALL. SEE WALL DETAILS ON SHEET WD1. SEE WALL PROFILES ON WP SHEETS.
  - 10 DRIVEWAY REMOVAL. SEE MP SHEETS FOR PLANTING PLAN.
  - 11 INSTALL PATTERNED CONCRETE DRIVEWAY. SEE DETAILS ON SHEET XX.
  - 12 INSTALL TYPE 1 REST STOP. SEE DETAILS ON SHEET XX.
  - 13 INSTALL TYPE 2 REST STOP. SEE DETAILS ON SHEET XX.
  - 14 INSTALL SOLDIER PILE WALL.
  - 15 INSTALL GRAVITY BLOCK WALL.
  - 16 INSTALL WING WALL, SEE FP SHEETS.
  - 17 INSTALL EXTRUDED CURB PER WSDOT STD PLAN F-10.42-00.
  - 18 REST STOP PULL-OUT.
  - 19 STAIRS WILL BE ELIMINATED DURING CONSTRUCTION.
  - 20 BRIDGES WILL BE REMOVED TO R/W LINE DURING CONSTRUCTION.
  - 21 INSTALL ROCK WALL.

- STORMWATER CONSTRUCTION NOTES:**
- 1 INFILTRATION TRENCH, SEE DETAIL 4 ON SHEET DD1.
  - 2 UNDERDRAIN TRENCH, SEE DETAIL 5 ON SHEET DD1.
  - 3 ROCK PAD, SEE DETAIL 2 ON SHEET DD1 AND WP SHEETS.
  - 4 CONNECTION TO DRAINAGE STRUCTURE AND CLEANING EXISTING DRAINAGE STRUCTURE.
  - 5 INSTALL UNDERDRAIN TRENCH CLEANOUT, SEE DETAIL 6 ON SHEET DD1.
  - 6 INSTALL RECTANGULAR SLIP RESISTANT SOLID METAL COVER PER WSDOT STD DETAIL B-30.20-02.
  - 7 CONCRETE HEADWALL, SEE DETAIL 1 ON SHEET DD1.
  - 8 BASIC DISPERSION, SEE SHEET CS3.
  - 9 QUARRY SPALL OUTFALL PROTECTION. SEE DETAIL 3 ON SHEET DD1.
  - 10 ADJUST CATCH BASIN.

- LEGEND:**
- RETAINING WALL
  - SOLDIER PILE WALL
  - WOOD GUARDRAIL
  - DISPERSION AREA
  - DRIVEWAY REMOVAL

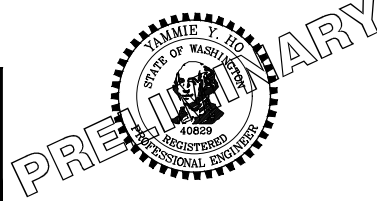
CITY OF SAMMAMISH APPROVAL	
City Engineer _____	Date _____
Community Development _____	Date _____

**60% REVIEW SUBMITTAL**  
 NOT FOR CONSTRUCTION

REVISIONS	DATE	BY	DESIGNED
			M. TSUN
			B. PURGANAN
			P. JOHANNESSEN
			Y. HO

**ONE INCH AT FULL SCALE, IF NOT, SCALE ACCORDINGLY**

FILE NAME: BL1521075P19T03AL-02  
 JOB No.: 1521-075 P19 T03  
 DATE: SEPTEMBER 2016



**Parametrix**  
 ENGINEERING · PLANNING · ENVIRONMENTAL SCIENCES

719 2ND AVENUE, SUITE 200 | SEATTLE, WA 98104  
 P 206.394.3700  
 WWW.PARAMETRIX.COM

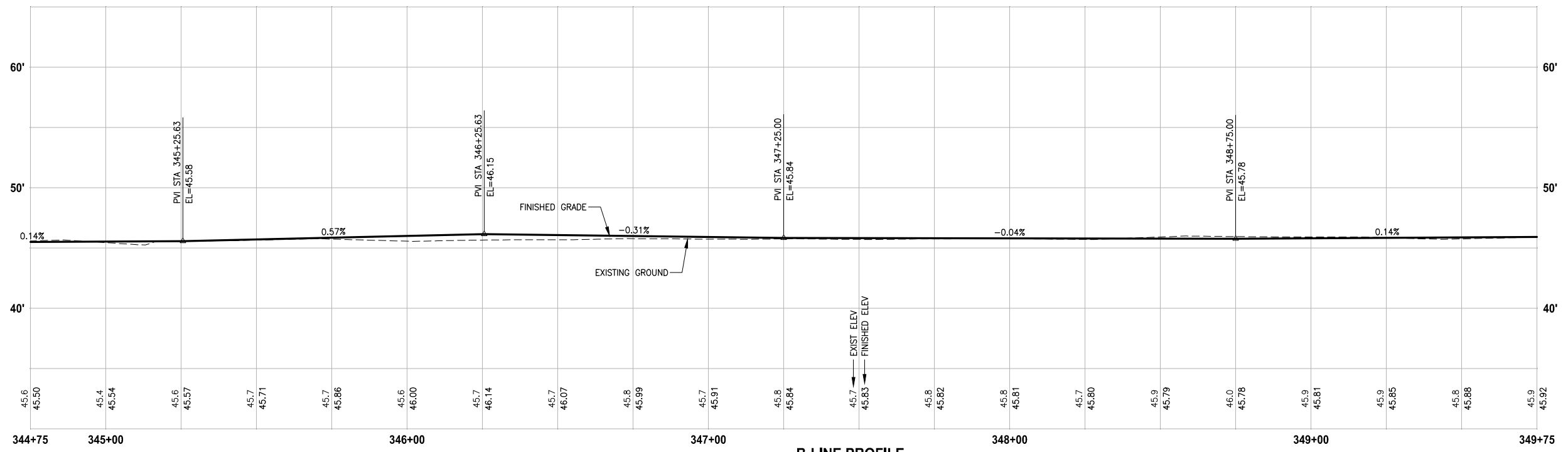
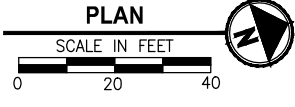
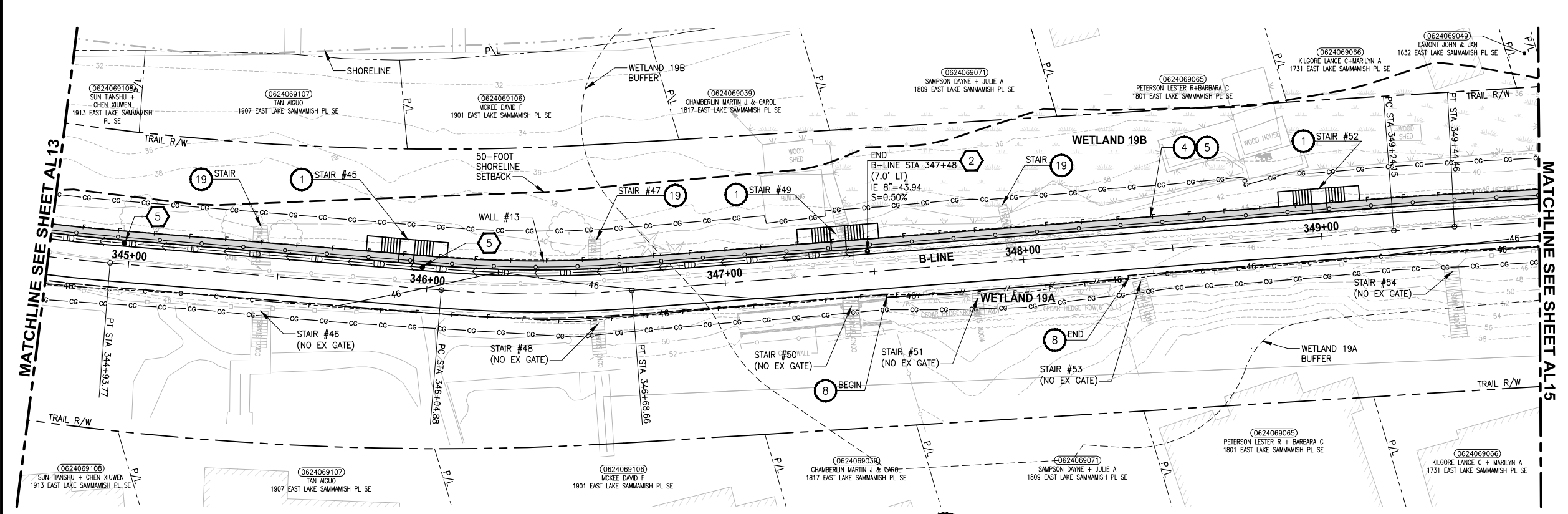
PROJECT NAME  
**EAST LAKE SAMMAMISH  
 MASTER PLAN TRAIL  
 SOUTH SAMMAMISH SEGMENT B**  
 SAMMAMISH, WA

**PLAN AND PROFILE**

SHEET NO.  
 45 OF 135  
**AL13**



PATH: U:\PSO\Projects\Clients\1521-KingCo\1521-075-ELST\995\Drawings\CADD\Phase 19\T03\_Civil\Draw\ AL14



**B-LINE PROFILE**  
 HORIZ: 1"=20'  
 VERT: 1"=5'

- CIVIL CONSTRUCTION NOTES:**
- RESTORE AND INSTALL STAIR. TYPE TO BE DETERMINED.
  - RECONSTRUCT PEDESTRIAN BRIDGE.
  - INSTALL PRECAST REINF CONC SPLIT BOX CULVERT. SEE FP SHEETS FOR DETAILS.
  - INSTALL STRUCTURAL EARTH WALL. SEE WALL DETAILS ON SHEET X. SEE WALL PROFILES ON WP SHEETS.
  - INSTALL COATED CHAIN LINK FENCE TYPE 6. FOR GROUND POST INSTALLATION SEE APPENDIX B IN THE SPECIFICATIONS. SEE SHEET X FOR MOUNTING ON TOP OF WALL.
  - NEW DRIVEWAY.
  - INSTALL WOOD GUARDRAIL, SEE DETAILS ON SHEET XX.
  - INSTALL SPLIT RAIL FENCE, SEE DETAILS ON SHEET XX.
  - INSTALL GRAVITY BLOCK WALL. SEE WALL DETAILS ON SHEET WD1. SEE WALL PROFILES ON WP SHEETS.
  - DRIVEWAY REMOVAL. SEE MP SHEETS FOR PLANTING PLAN.
  - INSTALL PATTERNED CONCRETE DRIVEWAY. SEE DETAILS ON SHEET XX.
  - INSTALL TYPE 1 REST STOP. SEE DETAILS ON SHEET XX.
  - INSTALL TYPE 2 REST STOP. SEE DETAILS ON SHEET XX.
  - INSTALL SOLDIER PILE WALL.
  - INSTALL GRAVITY BLOCK WALL.
  - INSTALL WING WALL, SEE FP SHEETS.
  - INSTALL EXTRUDED CURB PER WSDOT STD PLAN F-10.42-00.
  - REST STOP PULL-OUT.
  - STAIRS WILL BE ELIMINATED DURING CONSTRUCTION.
  - BRIDGES WILL BE REMOVED TO R/W LINE DURING CONSTRUCTION.
  - INSTALL ROCK WALL.

- STORMWATER CONSTRUCTION NOTES:**
- INFILTRATION TRENCH, SEE DETAIL 4 ON SHEET DD1.
  - UNDERDRAIN TRENCH, SEE DETAIL 5 ON SHEET DD1.
  - ROCK PAD, SEE DETAIL 2 ON SHEET DD1 AND WP SHEETS.
  - CONNECTION TO DRAINAGE STRUCTURE AND CLEANING EXISTING DRAINAGE STRUCTURE.
  - INSTALL UNDERDRAIN TRENCH CLEANOUT, SEE DETAIL 6 ON SHEET DD1.
  - INSTALL RECTANGULAR SLIP RESISTANT SOLID METAL COVER PER WSDOT STD DETAIL B-30.20-02.
  - CONCRETE HEADWALL, SEE DETAIL 1 ON SHEET DD1.
  - BASIC DISPERSION, SEE SHEET CS3.
  - QUARRY SPALL OUTFALL PROTECTION. SEE DETAIL 3 ON SHEET DD1.
  - ADJUST CATCH BASIN.

- LEGEND:**
- RETAINING WALL
  - SOLDIER PILE WALL
  - WOOD GUARDRAIL
  - DISPERSION AREA
  - DRIVEWAY REMOVAL

**CITY OF SAMMAMISH APPROVAL**

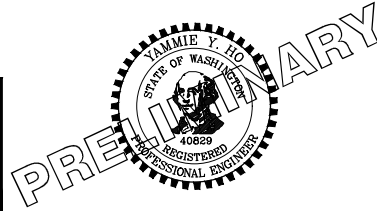
City Engineer _____	Date _____
Community Development _____	Date _____

**60% REVIEW SUBMITTAL**  
 NOT FOR CONSTRUCTION

REVISIONS	DATE	BY	DESIGNED
			M. TSUN
			B. PURGANAN
			P. JOHANNESSEN
			Y. HO

**ONE INCH AT FULL SCALE, IF NOT, SCALE ACCORDINGLY**

FILE NAME: BL1521075P19T03AL-02  
 JOB No.: 554-1521-075 P19 T03  
 DATE: SEPTEMBER 2016



**Parametrix**  
 ENGINEERING · PLANNING · ENVIRONMENTAL SCIENCES

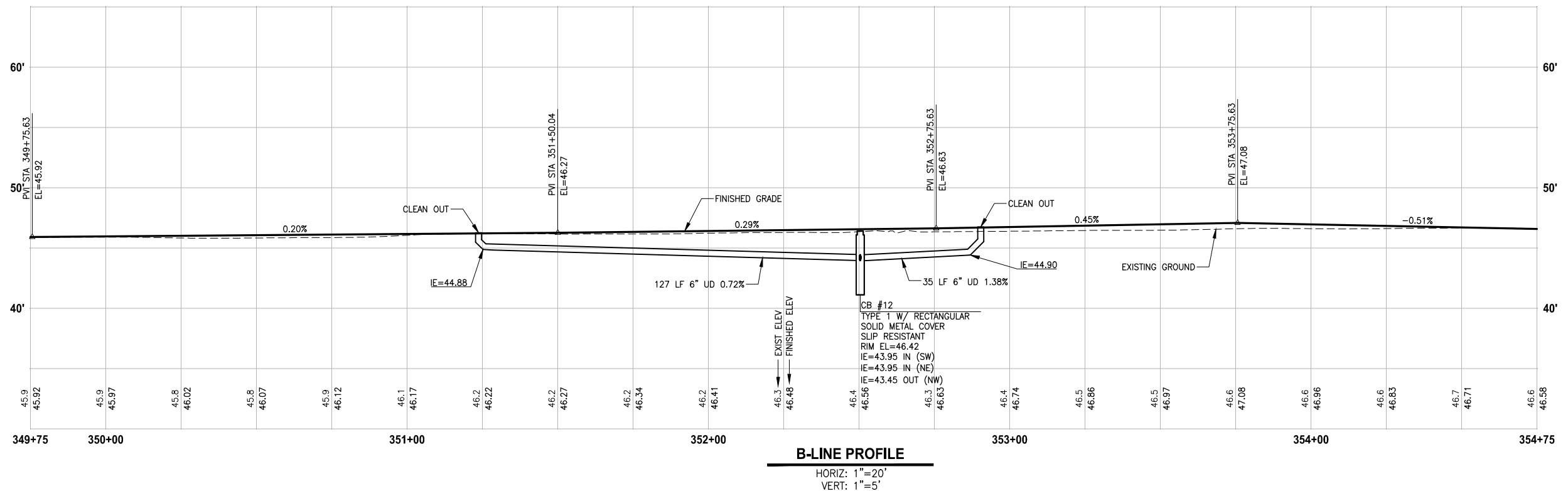
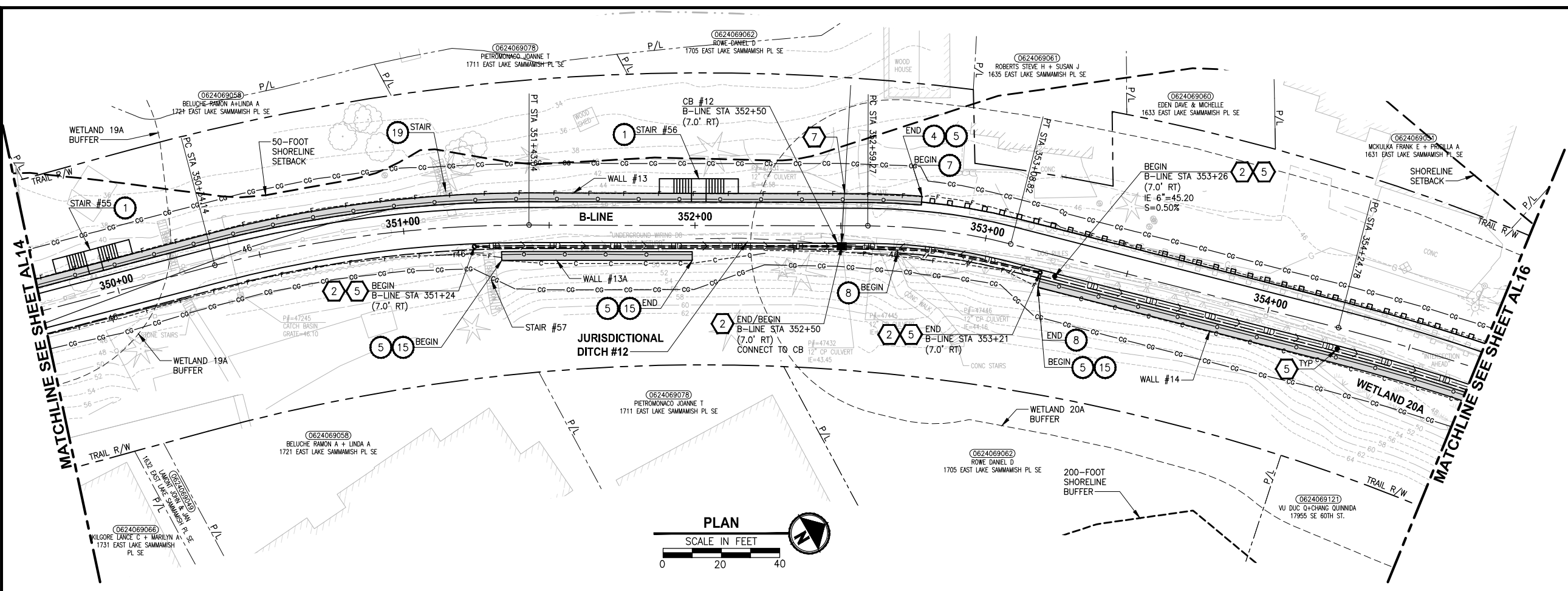
719 2ND AVENUE, SUITE 200 | SEATTLE, WA 98104  
 P 206.394.3700  
 WWW.PARAMETRIX.COM

PROJECT NAME  
**EAST LAKE SAMMAMISH MASTER PLAN TRAIL SOUTH SAMMAMISH SEGMENT B**  
 SAMMAMISH, WA

**PLAN AND PROFILE**

SHEET NO.  
 46 OF 135  
**AL14**

LAYOUT: AL15  
 PATH: U:\PSO\Projects\Clients\1521-KingCo\554-1521-075-ELST\995\Sub\CADD\Phase 19\T03\_Civil\DWG\ PLOTTED BY: purgabut DATE: Wednesday, October 12, 2016 9:00:09 PM



- CIVIL CONSTRUCTION NOTES:**
- 1 RESTORE AND INSTALL STAIR. TYPE TO BE DETERMINED.
  - 2 RECONSTRUCT PEDESTRIAN BRIDGE.
  - 3 INSTALL PRECAST REINF CONC SPLIT BOX CULVERT. SEE FP SHEETS FOR DETAILS.
  - 4 INSTALL STRUCTURAL EARTH WALL. SEE WALL DETAILS ON SHEET X. SEE WALL PROFILES ON WP SHEETS.
  - 5 INSTALL COATED CHAIN LINK FENCE TYPE 6. FOR GROUND POST INSTALLATION SEE APPENDIX B IN THE SPECIFICATIONS. SEE SHEET X FOR MOUNTING ON TOP OF WALL.
  - 6 NEW DRIVEWAY.
  - 7 INSTALL WOOD GUARDRAIL, SEE DETAILS ON SHEET XX.
  - 8 INSTALL SPLIT RAIL FENCE, SEE DETAILS ON SHEET XX.
  - 9 INSTALL GRAVITY BLOCK WALL. SEE WALL DETAILS ON SHEET WD1. SEE WALL PROFILES ON WP SHEETS.
  - 10 DRIVEWAY REMOVAL. SEE MP SHEETS FOR PLANTING PLAN.
  - 11 INSTALL PATTERNED CONCRETE DRIVEWAY. SEE DETAILS ON SHEET XX.
  - 12 INSTALL TYPE 1 REST STOP. SEE DETAILS ON SHEET XX.
  - 13 INSTALL TYPE 2 REST STOP. SEE DETAILS ON SHEET XX.
  - 14 INSTALL SOLDIER PILE WALL.
  - 15 INSTALL GRAVITY BLOCK WALL.
  - 16 INSTALL WING WALL. SEE FP SHEETS.
  - 17 INSTALL EXTRUDED CURB PER WSDOT STD PLAN F-10.42-00.
  - 18 REST STOP PULL-OUT.
  - 19 STAIRS WILL BE ELIMINATED DURING CONSTRUCTION.
  - 20 BRIDGES WILL BE REMOVED TO R/W LINE DURING CONSTRUCTION.
  - 21 INSTALL ROCK WALL.
- STORMWATER CONSTRUCTION NOTES:**
- 1 INFILTRATION TRENCH, SEE DETAIL 4 ON SHEET DD1.
  - 2 UNDERDRAIN TRENCH, SEE DETAIL 5 ON SHEET DD1.
  - 3 ROCK PAD, SEE DETAIL 2 ON SHEET DD1 AND WP SHEETS.
  - 4 CONNECTION TO DRAINAGE STRUCTURE AND CLEANING EXISTING DRAINAGE STRUCTURE.
  - 5 INSTALL UNDERDRAIN TRENCH CLEANOUT, SEE DETAIL 6 ON SHEET DD1.
  - 6 INSTALL RECTANGULAR SLIP RESISTANT SOLID METAL COVER PER WSDOT STD DETAIL B-30.20-02.
  - 7 CONCRETE HEADWALL, SEE DETAIL 1 ON SHEET DD1.
  - 8 BASIC DISPERSION, SEE SHEET CS3.
  - 9 QUARRY SPALL OUTFALL PROTECTION. SEE DETAIL 3 ON SHEET DD1.
  - 10 ADJUST CATCH BASIN.

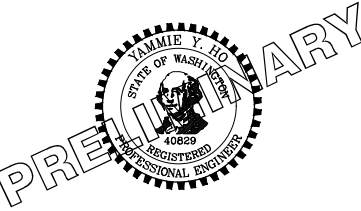
- LEGEND:**
- RETAINING WALL
  - SOLDIER PILE WALL
  - WOOD GUARDRAIL
  - DISPERSION AREA
  - DRIVEWAY REMOVAL

CITY OF SAMMAMISH APPROVAL	
City Engineer _____	Date _____
Community Development _____	Date _____

**60 % REVIEW SUBMITTAL  
NOT FOR CONSTRUCTION**

REVISIONS	DATE	BY	DESIGNED
			M. TSUN
			B. PURGANAN
			P. JOHANNESSEN
			Y. HO

**ONE INCH AT FULL SCALE, IF NOT, SCALE ACCORDINGLY**  
 FILE NAME: BL1521075P19T03AL-02  
 JOB No: 554-1521-075 P19 T03  
 DATE: SEPTEMBER 2016



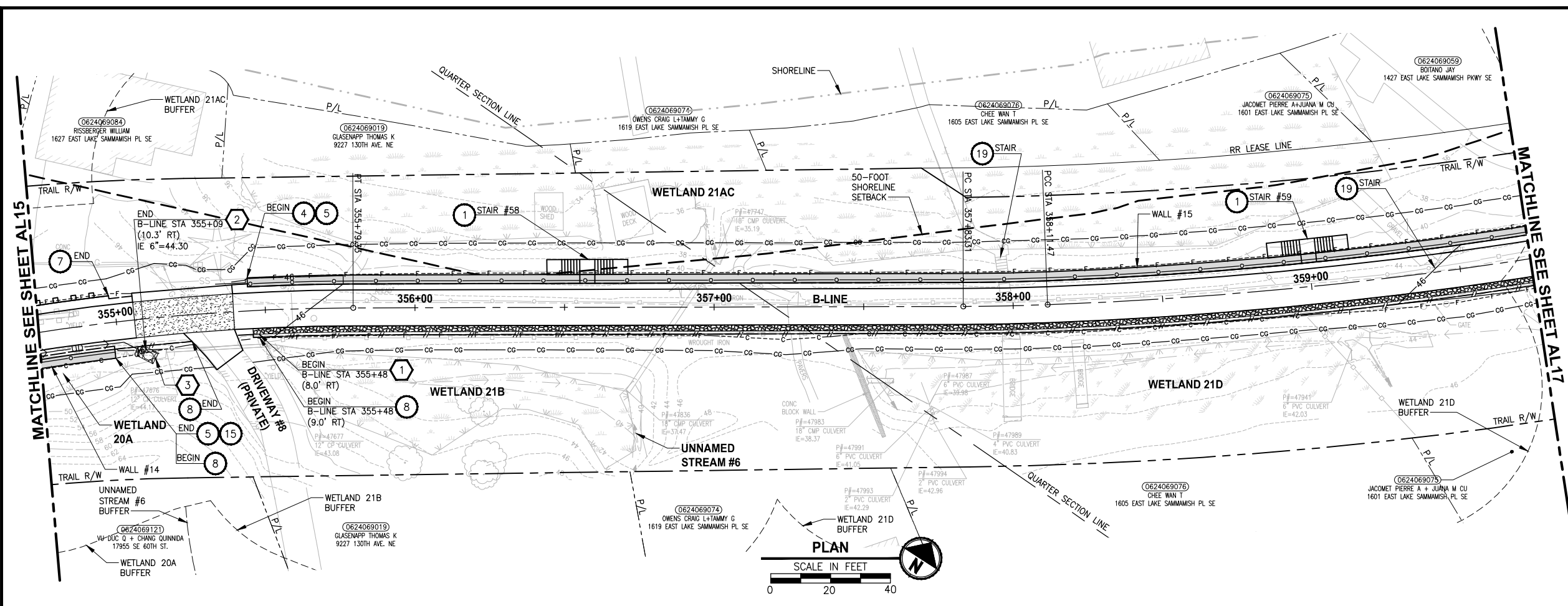
**Parametrix**  
 ENGINEERING · PLANNING · ENVIRONMENTAL SCIENCES  
 719 2ND AVENUE, SUITE 200 | SEATTLE, WA 98104  
 P 206.394.3700  
 WWW.PARAMETRIX.COM

PROJECT NAME  
**EAST LAKE SAMMAMISH  
 MASTER PLAN TRAIL  
 SOUTH SAMMAMISH SEGMENT B**  
 SAMMAMISH, WA

**PLAN AND PROFILE**  
 SHEET NO.  
 47 OF 135  
**AL15**



LAYOUT: AL16 PATH: U:\PSO\Projects\Clients\1521-KingCo\554-1521-075-ELST\995\cadd\Phase 19\T03\_Civil\DWG\ PLOTTED BY: purgabut DATE: Wednesday, October 12, 2016 9:00:40 PM



- CIVIL CONSTRUCTION NOTES:**
- 1 RESTORE AND INSTALL STAIR. TYPE TO BE DETERMINED.
  - 2 RECONSTRUCT PEDESTRIAN BRIDGE.
  - 3 INSTALL PRECAST REINF CONC SPLIT BOX CULVERT. SEE FP SHEETS FOR DETAILS.
  - 4 INSTALL STRUCTURAL EARTH WALL. SEE WALL DETAILS ON SHEET X. SEE WALL PROFILES ON WP SHEETS.
  - 5 INSTALL COATED CHAIN LINK FENCE TYPE 6. FOR GROUND POST INSTALLATION SEE APPENDIX B IN THE SPECIFICATIONS. SEE SHEET X FOR MOUNTING ON TOP OF WALL.
  - 6 NEW DRIVEWAY.
  - 7 INSTALL WOOD GUARDRAIL, SEE DETAILS ON SHEET XX.
  - 8 INSTALL SPLIT RAIL FENCE, SEE DETAILS ON SHEET XX.
  - 9 INSTALL GRAVITY BLOCK WALL. SEE WALL DETAILS ON SHEET WD1. SEE WALL PROFILES ON WP SHEETS.
  - 10 DRIVEWAY REMOVAL. SEE MP SHEETS FOR PLANTING PLAN.
  - 11 INSTALL PATTERNED CONCRETE DRIVEWAY. SEE DETAILS ON SHEET XX.
  - 12 INSTALL TYPE 1 REST STOP. SEE DETAILS ON SHEET XX.
  - 13 INSTALL TYPE 2 REST STOP. SEE DETAILS ON SHEET XX.
  - 14 INSTALL SOLDIER PILE WALL.
  - 15 INSTALL GRAVITY BLOCK WALL.
  - 16 INSTALL WING WALL, SEE FP SHEETS.
  - 17 INSTALL EXTRUDED CURB PER WSDOT STD PLAN F-10.42-00.
  - 18 REST STOP PULL-OUT.
  - 19 STAIRS WILL BE ELIMINATED DURING CONSTRUCTION.
  - 20 BRIDGES WILL BE REMOVED TO R/W LINE DURING CONSTRUCTION.
  - 21 INSTALL ROCK WALL.

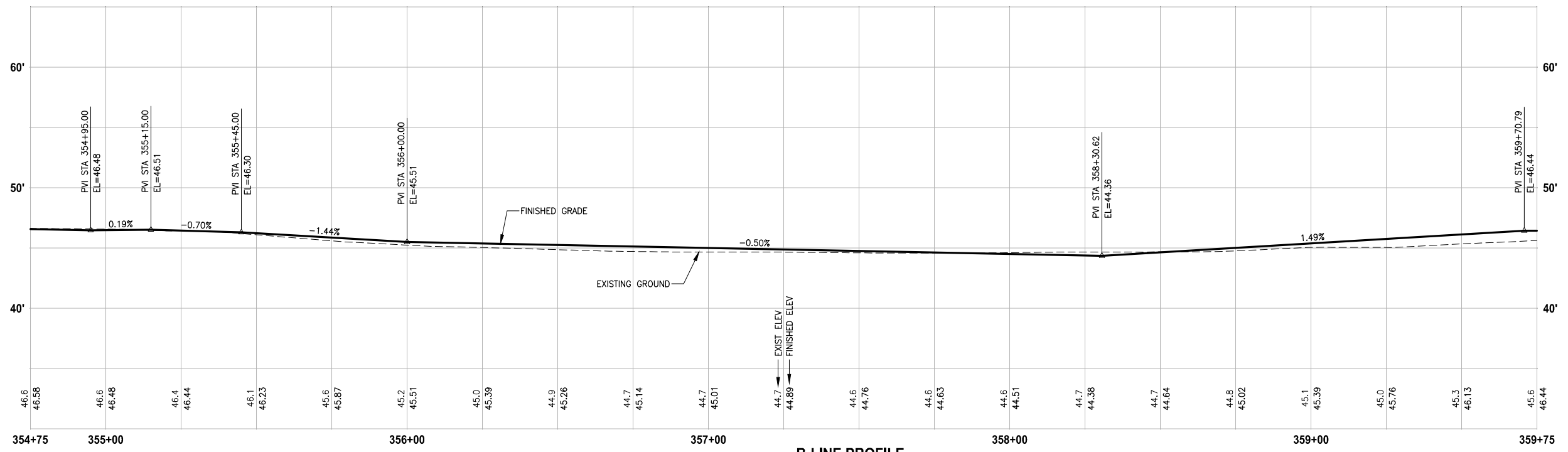
- STORMWATER CONSTRUCTION NOTES:**
- 1 INFILTRATION TRENCH, SEE DETAIL 4 ON SHEET DD1.
  - 2 UNDERDRAIN TRENCH, SEE DETAIL 5 ON SHEET DD1.
  - 3 ROCK PAD, SEE DETAIL 2 ON SHEET DD1 AND WP SHEETS.
  - 4 CONNECTION TO DRAINAGE STRUCTURE AND CLEANING EXISTING DRAINAGE STRUCTURE.
  - 5 INSTALL UNDERDRAIN TRENCH CLEANOUT, SEE DETAIL 6 ON SHEET DD1.
  - 6 INSTALL RECTANGULAR SLIP RESISTANT SOLID METAL COVER PER WSDOT STD DETAIL B-30.20-02.
  - 7 CONCRETE HEADWALL, SEE DETAIL 1 ON SHEET DD1.
  - 8 BASIC DISPERSION, SEE SHEET CS3.
  - 9 QUARRY SPALL OUTFALL PROTECTION. SEE DETAIL 3 ON SHEET DD1.
  - 10 ADJUST CATCH BASIN.

- LEGEND:**
- RETAINING WALL
  - SOLDIER PILE WALL
  - WOOD GUARDRAIL
  - DISPERSION AREA
  - DRIVEWAY REMOVAL

**CITY OF SAMMAMISH APPROVAL**

City Engineer _____	Date _____
Community Development _____	Date _____

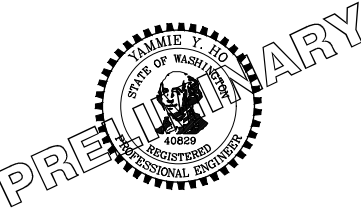
**60 % REVIEW SUBMITTAL  
NOT FOR CONSTRUCTION**



REVISIONS	DATE	BY	DESIGNED
			M. TSUN
			B. PURGANAN
			P. JOHANNESSEN
			Y. HO

**ONE INCH AT FULL SCALE, IF NOT, SCALE ACCORDINGLY**

FILE NAME: BL1521075P19T03AL-02  
JOB No.: 554-1521-075 P19 T03  
DATE: SEPTEMBER 2016



**Parametrix**  
ENGINEERING · PLANNING · ENVIRONMENTAL SCIENCES

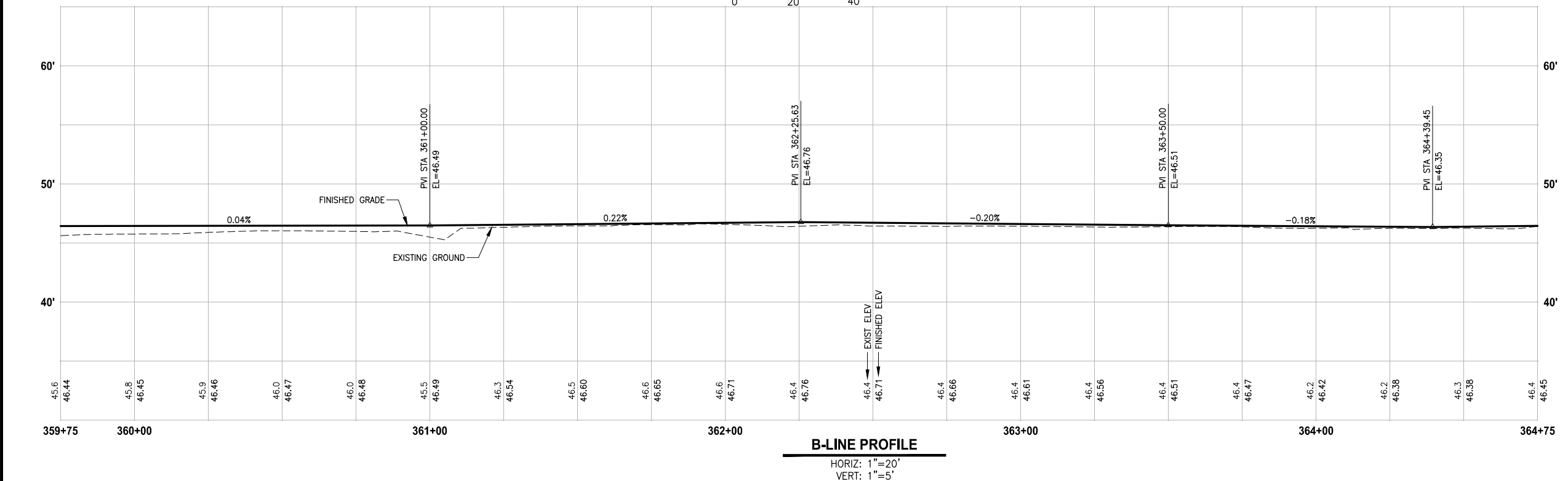
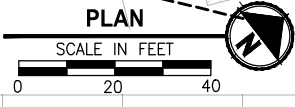
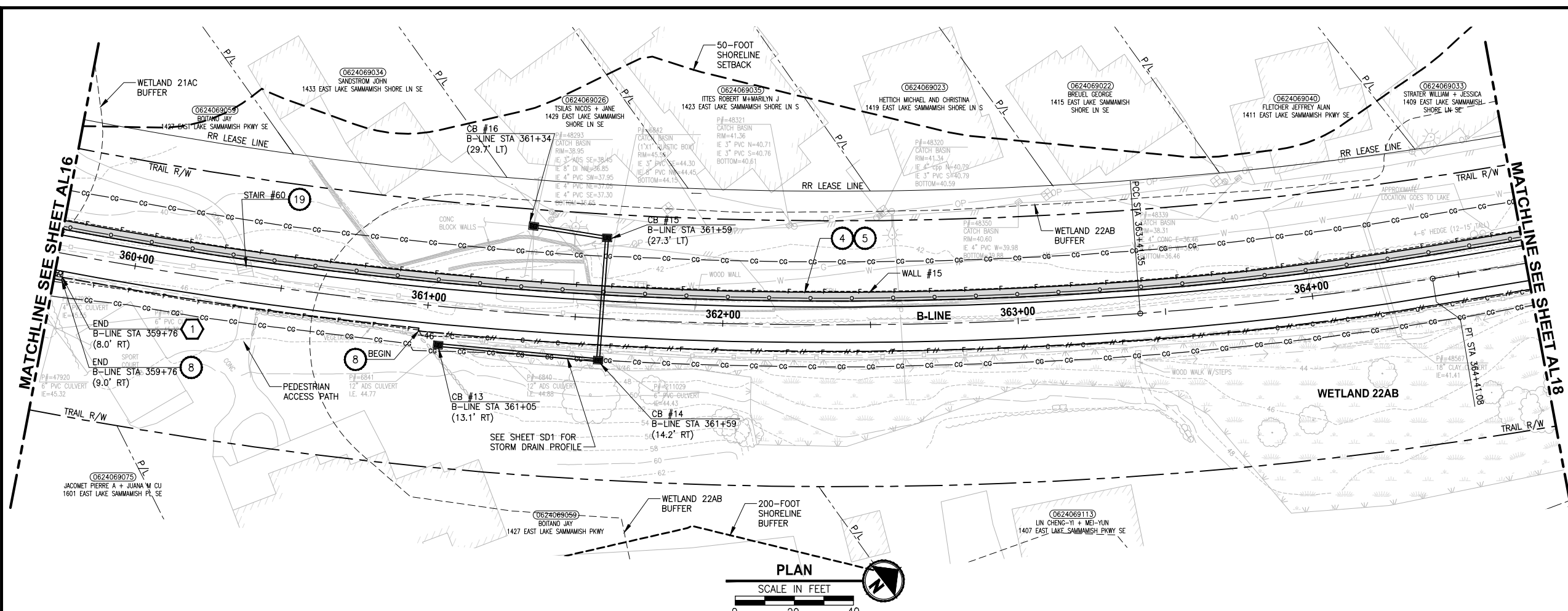
719 2ND AVENUE, SUITE 200 | SEATTLE, WA 98104  
P 206.394.3700  
WWW.PARAMETRIX.COM

PROJECT NAME  
**EAST LAKE SAMMAMISH  
MASTER PLAN TRAIL  
SOUTH SAMMAMISH SEGMENT B**  
SAMMAMISH, WA

**PLAN AND PROFILE**

SHEET NO.  
48 OF 135  
**AL16**

LAYOUT: AL17  
 PATH: U:\PSO\Projects\Clients\1521-KingCo\1521-075-ELST\995\995\CADD\Phase 19\T03\_Civil\DWG\ PLOTTED BY: purgabut DATE: Wednesday, October 12, 2016 9:01:06 PM



**B-LINE PROFILE**  
 HORIZ: 1"=20'  
 VERT: 1"=5'

- CIVIL CONSTRUCTION NOTES:**
- 1 RESTORE AND INSTALL STAIR. TYPE TO BE DETERMINED.
  - 2 RECONSTRUCT PEDESTRIAN BRIDGE.
  - 3 INSTALL PRECAST REINF CONC SPLIT BOX CULVERT. SEE FP SHEETS FOR DETAILS.
  - 4 INSTALL STRUCTURAL EARTH WALL. SEE WALL DETAILS ON SHEET X. SEE WALL PROFILES ON WP SHEETS.
  - 5 INSTALL COATED CHAIN LINK FENCE TYPE 6. FOR GROUND POST INSTALLATION SEE APPENDIX B IN THE SPECIFICATIONS. SEE SHEET X FOR MOUNTING ON TOP OF WALL.
  - 6 NEW DRIVEWAY.
  - 7 INSTALL WOOD GUARDRAIL, SEE DETAILS ON SHEET XX.
  - 8 INSTALL SPLIT RAIL FENCE, SEE DETAILS ON SHEET XX.
  - 9 INSTALL GRAVITY BLOCK WALL. SEE WALL DETAILS ON SHEET WD1. SEE WALL PROFILES ON WP SHEETS.
  - 10 DRIVEWAY REMOVAL. SEE MP SHEETS FOR PLANTING PLAN.
  - 11 INSTALL PATTERNED CONCRETE DRIVEWAY. SEE DETAILS ON SHEET XX.
  - 12 INSTALL TYPE 1 REST STOP. SEE DETAILS ON SHEET XX.
  - 13 INSTALL TYPE 2 REST STOP. SEE DETAILS ON SHEET XX.
  - 14 INSTALL SOLDIER PILE WALL.
  - 15 INSTALL GRAVITY BLOCK WALL.
  - 16 INSTALL WING WALL, SEE FP SHEETS.
  - 17 INSTALL EXTRUDED CURB PER WSDOT STD PLAN F-10.42-00.
  - 18 REST STOP PULL-OUT.
  - 19 STAIRS WILL BE ELIMINATED DURING CONSTRUCTION.
  - 20 BRIDGES WILL BE REMOVED TO R/W LINE DURING CONSTRUCTION.
  - 21 INSTALL ROCK WALL.

- STORMWATER CONSTRUCTION NOTES:**
- 1 INFILTRATION TRENCH, SEE DETAIL 4 ON SHEET DD1.
  - 2 UNDERDRAIN TRENCH, SEE DETAIL 5 ON SHEET DD1.
  - 3 ROCK PAD, SEE DETAIL 2 ON SHEET DD1 AND WP SHEETS.
  - 4 CONNECTION TO DRAINAGE STRUCTURE AND CLEANING EXISTING DRAINAGE STRUCTURE.
  - 5 INSTALL UNDERDRAIN TRENCH CLEANOUT, SEE DETAIL 6 ON SHEET DD1.
  - 6 INSTALL RECTANGULAR SLIP RESISTANT SOLID METAL COVER PER WSDOT STD DETAIL B-30.20-02.
  - 7 CONCRETE HEADWALL, SEE DETAIL 1 ON SHEET DD1.
  - 8 BASIC DISPERSION, SEE SHEET CS3.
  - 9 QUARRY SPALL OUTFALL PROTECTION. SEE DETAIL 3 ON SHEET DD1.
  - 10 ADJUST CATCH BASIN.

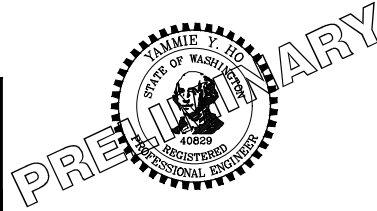
- LEGEND:**
- RETAINING WALL
  - SOLDIER PILE WALL
  - WOOD GUARDRAIL
  - DISPERSION AREA
  - DRIVEWAY REMOVAL

CITY OF SAMMAMISH APPROVAL	
City Engineer _____	Date _____
Community Development _____	Date _____

**60 % REVIEW SUBMITTAL**  
 NOT FOR CONSTRUCTION

REVISIONS	DATE	BY	DESIGNED
			M. TSUN
			B. PURGANAN
			P. JOHANNESSEN
			Y. HO

ONE INCH AT FULL SCALE.  
 IF NOT, SCALE ACCORDINGLY.  
 FILE NAME: BL1521075P19T03AL-02  
 JOB No.: 554-1521-075 P19 T03  
 DATE: SEPTEMBER 2016



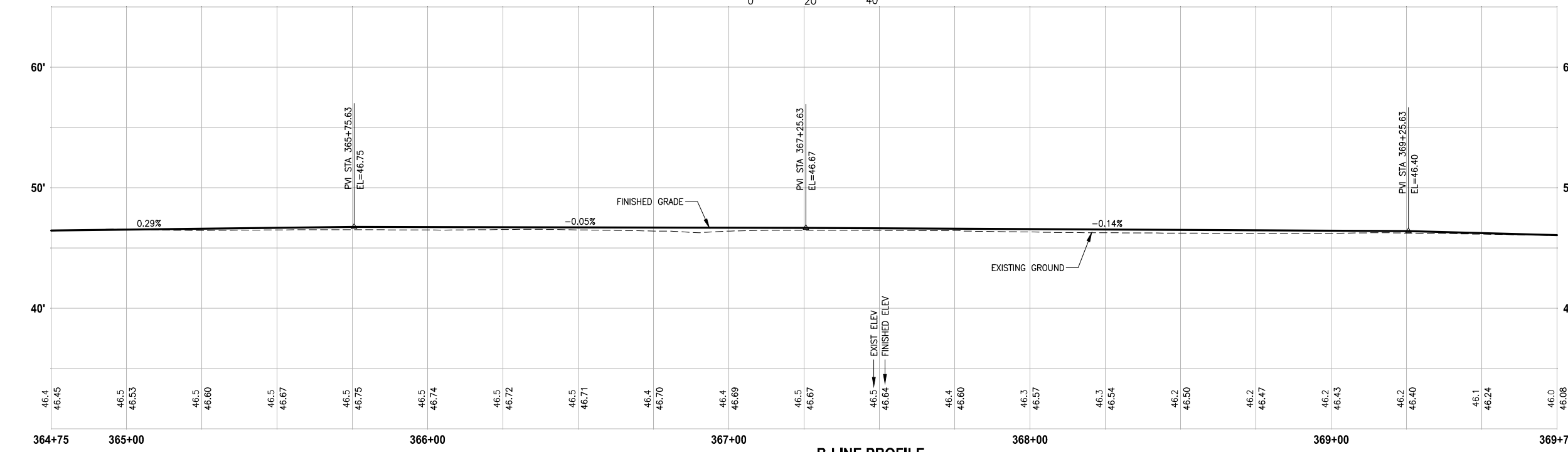
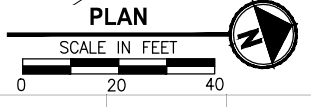
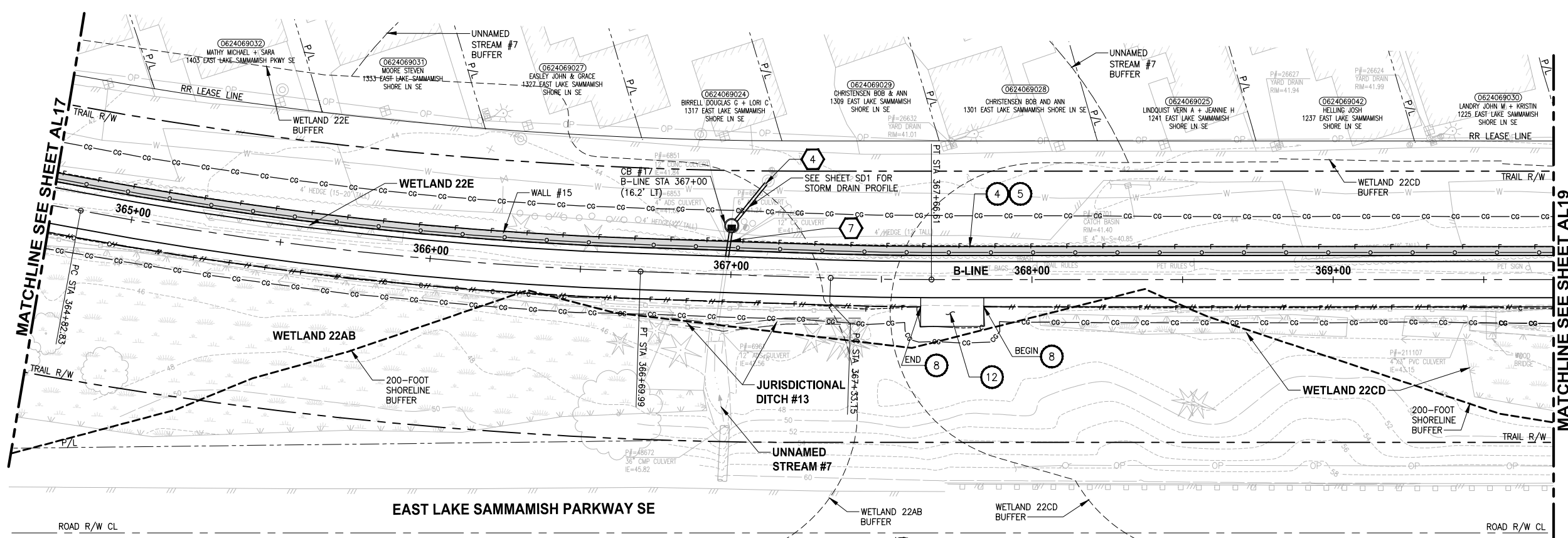
**Parametrix**  
 ENGINEERING · PLANNING · ENVIRONMENTAL SCIENCES  
 719 2ND AVENUE, SUITE 200 | SEATTLE, WA 98104  
 P 206.394.3700  
 WWW.PARAMETRIX.COM

PROJECT NAME  
**EAST LAKE SAMMAMISH  
 MASTER PLAN TRAIL  
 SOUTH SAMMAMISH SEGMENT B**  
 SAMMAMISH, WA

**PLAN AND PROFILE**  
 SHEET NO.  
 49 OF 135  
**AL17**



PATH: U:\PSO\Projects\Clients\1521-KingCo\1521-075-ELST\995\Drawings\CADD\Phase 19\T03\_Civil\DWG\ LAYOUT: AL18 PLOTTED BY: purgaban DATE: Wednesday, October 12, 2016 9:01:40 PM



**B-LINE PROFILE**

HORIZ: 1"=20'  
VERT: 1"=5'

**CIVIL CONSTRUCTION NOTES:**

- 1 RESTORE AND INSTALL STAIR. TYPE TO BE DETERMINED.
- 2 RECONSTRUCT PEDESTRIAN BRIDGE.
- 3 INSTALL PRECAST REINF CONC SPLIT BOX CULVERT. SEE FP SHEETS FOR DETAILS.
- 4 INSTALL STRUCTURAL EARTH WALL. SEE WALL DETAILS ON SHEET X. SEE WALL PROFILES ON WP SHEETS.
- 5 INSTALL COATED CHAIN LINK FENCE TYPE 6. FOR GROUND POST INSTALLATION SEE APPENDIX B IN THE SPECIFICATIONS. SEE SHEET X FOR MOUNTING ON TOP OF WALL.
- 6 NEW DRIVEWAY.
- 7 INSTALL WOOD GUARDRAIL, SEE DETAILS ON SHEET XX.
- 8 INSTALL SPLIT RAIL FENCE, SEE DETAILS ON SHEET XX.
- 9 INSTALL GRAVITY BLOCK WALL. SEE WALL DETAILS ON SHEET WD1. SEE WALL PROFILES ON WP SHEETS.
- 10 DRIVEWAY REMOVAL. SEE MP SHEETS FOR PLANTING PLAN.
- 11 INSTALL PATTERNED CONCRETE DRIVEWAY. SEE DETAILS ON SHEET XX.
- 12 INSTALL TYPE 1 REST STOP. SEE DETAILS ON SHEET XX.
- 13 INSTALL TYPE 2 REST STOP. SEE DETAILS ON SHEET XX.
- 14 INSTALL SOLDIER PILE WALL.
- 15 INSTALL GRAVITY BLOCK WALL.
- 16 INSTALL WING WALL. SEE FP SHEETS.
- 17 INSTALL EXTRUDED CURB PER WSDOT STD PLAN F-10.42-00.
- 18 REST STOP PULL-OUT.
- 19 STAIRS WILL BE ELIMINATED DURING CONSTRUCTION.
- 20 BRIDGES WILL BE REMOVED TO R/W LINE DURING CONSTRUCTION.
- 21 INSTALL ROCK WALL.

**STORMWATER CONSTRUCTION NOTES:**

- 1 INFILTRATION TRENCH, SEE DETAIL 4 ON SHEET DD1.
- 2 UNDERDRAIN TRENCH, SEE DETAIL 5 ON SHEET DD1.
- 3 ROCK PAD, SEE DETAIL 2 ON SHEET DD1 AND WP SHEETS.
- 4 CONNECTION TO DRAINAGE STRUCTURE AND CLEANING EXISTING DRAINAGE STRUCTURE.
- 5 INSTALL UNDERDRAIN TRENCH CLEANOUT, SEE DETAIL 6 ON SHEET DD1.
- 6 INSTALL RECTANGULAR SLIP RESISTANT SOLID METAL COVER PER WSDOT STD DETAIL B-30.20-02.
- 7 CONCRETE HEADWALL, SEE DETAIL 1 ON SHEET DD1.
- 8 BASIC DISPERSION, SEE SHEET CS3.
- 9 QUARRY SPALL OUTFALL PROTECTION. SEE DETAIL 3 ON SHEET DD1.
- 10 ADJUST CATCH BASIN.

**LEGEND:**

- RETAINING WALL
- SOLDIER PILE WALL
- WOOD GUARDRAIL
- DISPERSION AREA
- DRIVEWAY REMOVAL

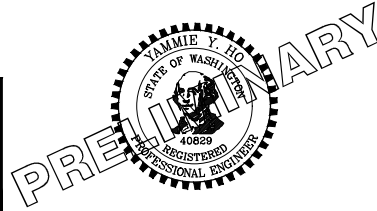
CITY OF SAMMAMISH APPROVAL	
City Engineer _____	Date _____
Community Development _____	Date _____

**60 % REVIEW SUBMITTAL**  
NOT FOR CONSTRUCTION

REVISIONS	DATE	BY	DESIGNED
			M. TSUN
			B. PURGANAN
			P. JOHANNESSEN
			Y. HO

**ONE INCH AT FULL SCALE, IF NOT, SCALE ACCORDINGLY**

FILE NAME: BL1521075P19T03AL-02  
JOB No.: 554-1521-075 P19 T03  
DATE: SEPTEMBER 2016



**Parametrix**  
ENGINEERING · PLANNING · ENVIRONMENTAL SCIENCES

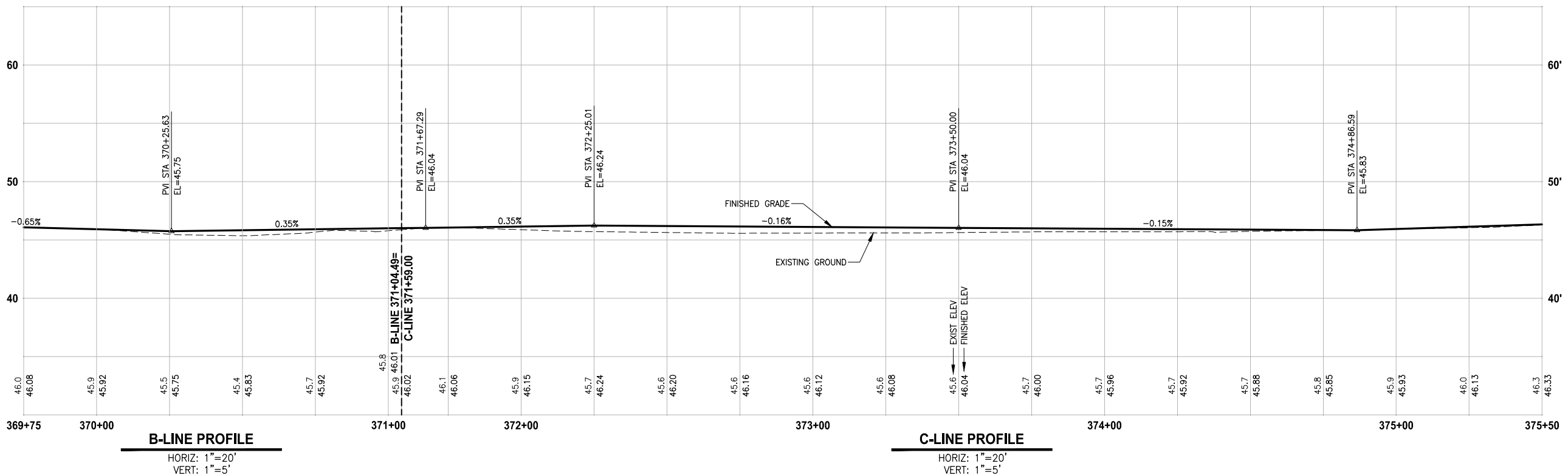
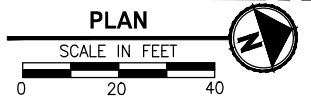
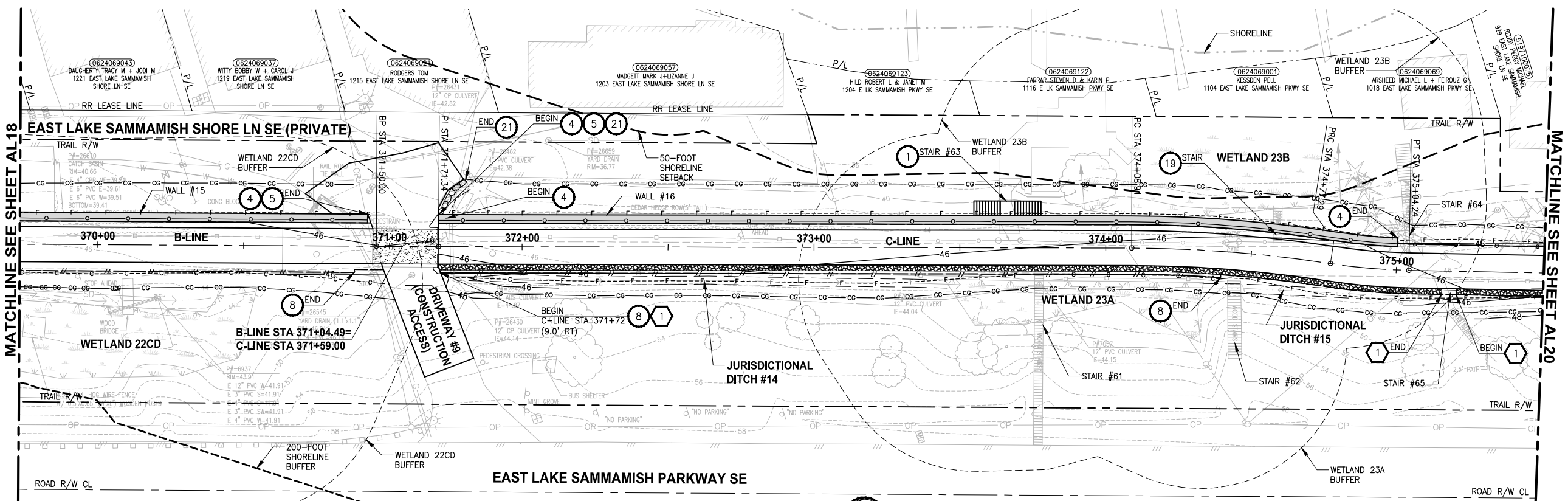
719 2ND AVENUE, SUITE 200 | SEATTLE, WA 98104  
P 206.394.3700  
WWW.PARAMETRIX.COM

PROJECT NAME  
**EAST LAKE SAMMAMISH MASTER PLAN TRAIL SOUTH SAMMAMISH SEGMENT B**  
SAMMAMISH, WA

**PLAN AND PROFILE**

SHEET NO.  
50 OF 135  
**AL18**

PATH: U:\PSO\Projects\Clients\554-1521-075-ELST\995\Sub\CADD\Phase 19\T03\_Civil\DWG\ PLOTTED BY: purgabul DATE: Wednesday, October 12, 2016 9:07:18 PM LAYOUT: AL19



- CIVIL CONSTRUCTION NOTES:**
- 1 RESTORE AND INSTALL STAIR. TYPE TO BE DETERMINED.
  - 2 RECONSTRUCT PEDESTRIAN BRIDGE.
  - 3 INSTALL PRECAST REINF CONC SPLIT BOX CULVERT. SEE FP SHEETS FOR DETAILS.
  - 4 INSTALL STRUCTURAL EARTH WALL. SEE WALL DETAILS ON SHEET X. SEE WALL PROFILES ON WP SHEETS.
  - 5 INSTALL COATED CHAIN LINK FENCE TYPE 6. FOR GROUND POST INSTALLATION SEE APPENDIX B IN THE SPECIFICATIONS. SEE SHEET X FOR MOUNTING ON TOP OF WALL.
  - 6 NEW DRIVEWAY.
  - 7 INSTALL WOOD GUARDRAIL, SEE DETAILS ON SHEET XX.
  - 8 INSTALL SPLIT RAIL FENCE, SEE DETAILS ON SHEET XX.
  - 9 INSTALL GRAVITY BLOCK WALL. SEE WALL DETAILS ON SHEET WD1. SEE WALL PROFILES ON WP SHEETS.
  - 10 DRIVEWAY REMOVAL. SEE MP SHEETS FOR PLANTING PLAN.
  - 11 INSTALL PATTERNED CONCRETE DRIVEWAY. SEE DETAILS ON SHEET XX.
  - 12 INSTALL TYPE 1 REST STOP. SEE DETAILS ON SHEET XX.
  - 13 INSTALL TYPE 2 REST STOP. SEE DETAILS ON SHEET XX.
  - 14 INSTALL SOLDIER PILE WALL.
  - 15 INSTALL GRAVITY BLOCK WALL.
  - 16 INSTALL WING WALL. SEE FP SHEETS.
  - 17 INSTALL EXTRUDED CURB PER WSDOT STD PLAN F-10.42-00.
  - 18 REST STOP PULL-OUT.
  - 19 STAIRS WILL BE ELIMINATED DURING CONSTRUCTION.
  - 20 BRIDGES WILL BE REMOVED TO R/W LINE DURING CONSTRUCTION.
  - 21 INSTALL ROCK WALL.

- STORMWATER CONSTRUCTION NOTES:**
- 1 INFILTRATION TRENCH, SEE DETAIL 4 ON SHEET DD1.
  - 2 UNDERDRAIN TRENCH, SEE DETAIL 5 ON SHEET DD1.
  - 3 ROCK PAD, SEE DETAIL 2 ON SHEET DD1 AND WP SHEETS.
  - 4 CONNECTION TO DRAINAGE STRUCTURE AND CLEANING EXISTING DRAINAGE STRUCTURE.
  - 5 INSTALL UNDERDRAIN TRENCH CLEANOUT, SEE DETAIL 6 ON SHEET DD1.
  - 6 INSTALL RECTANGULAR SLIP RESISTANT SOLID METAL COVER PER WSDOT STD DETAIL B-30.20-02.
  - 7 CONCRETE HEADWALL, SEE DETAIL 1 ON SHEET DD1.
  - 8 BASIC DISPERSION, SEE SHEET CS3.
  - 9 QUARRY SPALL OUTFALL PROTECTION. SEE DETAIL 3 ON SHEET DD1.
  - 10 ADJUST CATCH BASIN.

- LEGEND:**
- RETAINING WALL
  - SOLDIER PILE WALL
  - WOOD GUARDRAIL
  - DISPERSION AREA
  - DRIVEWAY REMOVAL

**CITY OF SAMMAMISH APPROVAL**

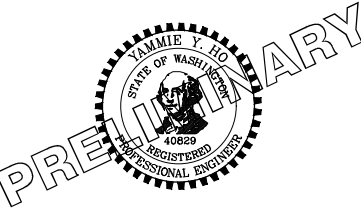
City Engineer _____	Date _____
Community Development _____	Date _____

**60 % REVIEW SUBMITTAL  
NOT FOR CONSTRUCTION**

REVISIONS	DATE	BY	DESIGNED
			M. TSUN
			B. PURGANAN
			P. JOHANNESSEN
			Y. HO

**ONE INCH AT FULL SCALE.  
IF NOT, SCALE ACCORDINGLY**

FILE NAME: BL1521075P19T03AL-03  
JOB No: 554-1521-075 P19 T03  
DATE: SEPTEMBER 2016



**Parametrix**  
ENGINEERING · PLANNING · ENVIRONMENTAL SCIENCES

719 2ND AVENUE, SUITE 200 | SEATTLE, WA 98104  
P 206.394.3700  
WWW.PARAMETRIX.COM

PROJECT NAME  
**EAST LAKE SAMMAMISH  
MASTER PLAN TRAIL  
SOUTH SAMMAMISH SEGMENT B**  
SAMMAMISH, WA

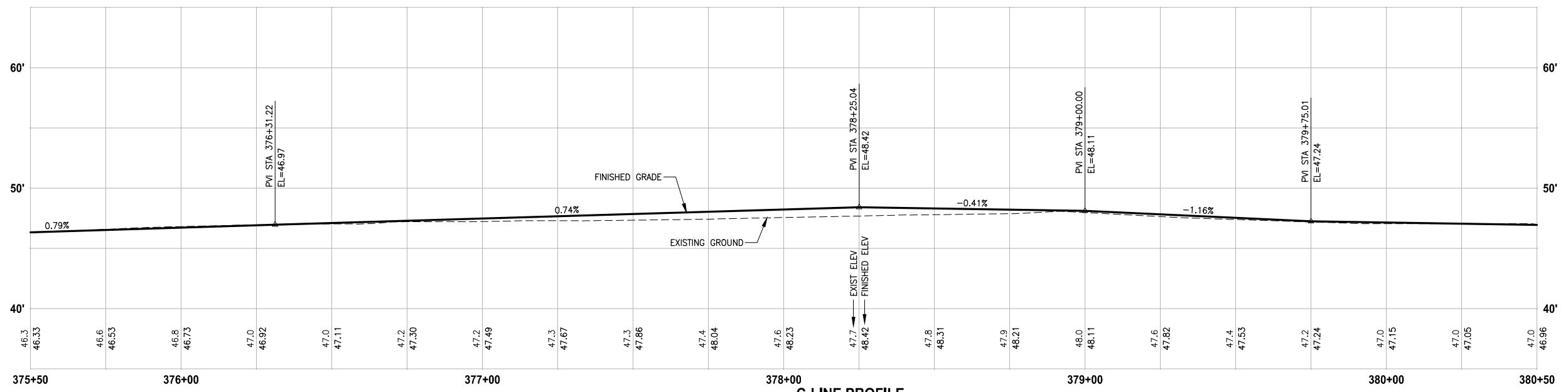
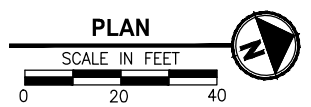
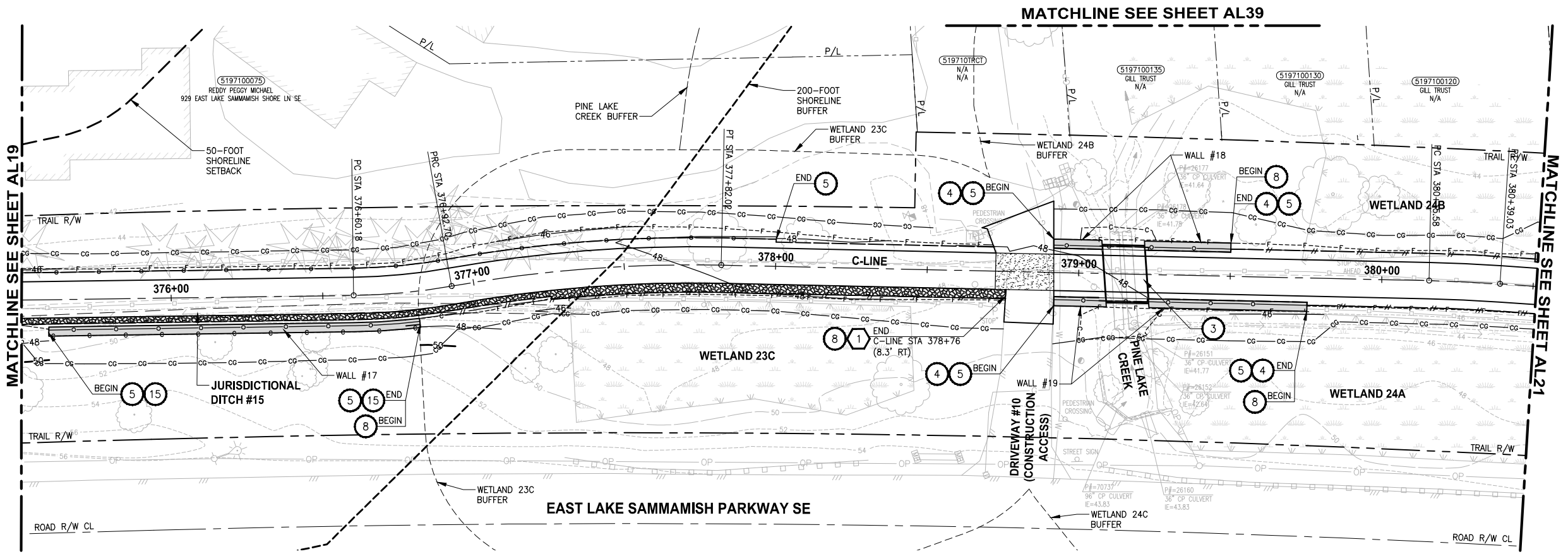
**PLAN AND PROFILE**

SHEET NO.  
51 OF 135

**AL19**

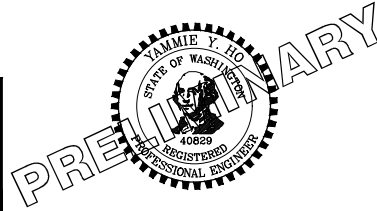


PATH: U:\PSO\Projects\Clients\1521-075-ELST\995\CA\ADD\Phase 19\T03\_Civil\Draw\ PLOTTED BY: purgabut DATE: Wednesday, October 12, 2016 9:07:51 PM LAYOUT: AL20



REVISIONS	DATE	BY	DESIGNED
			M. TSUN
			B. PURGANAN
			P. JOHANNESSEN
			Y. HO

ONE INCH AT FULL SCALE, IF NOT, SCALE ACCORDINGLY  
 FILE NAME: BL1521075P19T03AL-03  
 JOB No.: 554-1521-075 P19 T03  
 DATE: SEPTEMBER 2016



**Parametrix**  
 ENGINEERING · PLANNING · ENVIRONMENTAL SCIENCES  
 719 2ND AVENUE, SUITE 200 | SEATTLE, WA 98104  
 P 206.394.3700  
 WWW.PARAMETRIX.COM

PROJECT NAME  
**EAST LAKE SAMMAMISH MASTER PLAN TRAIL SOUTH SAMMAMISH SEGMENT B**  
 SAMMAMISH, WA

**PLAN AND PROFILE**

SHEET NO. 52 OF 135  
**AL20**

- CIVIL CONSTRUCTION NOTES:**
- RESTORE AND INSTALL STAIR. TYPE TO BE DETERMINED.
  - RECONSTRUCT PEDESTRIAN BRIDGE.
  - INSTALL PRECAST REINF CONC SPLIT BOX CULVERT. SEE FP SHEETS FOR DETAILS.
  - INSTALL STRUCTURAL EARTH WALL. SEE WALL DETAILS ON SHEET X. SEE WALL PROFILES ON WP SHEETS.
  - INSTALL COATED CHAIN LINK FENCE TYPE 6. FOR GROUND POST INSTALLATION SEE APPENDIX B IN THE SPECIFICATIONS. SEE SHEET X FOR MOUNTING ON TOP OF WALL.
  - NEW DRIVEWAY.
  - INSTALL WOOD GUARDRAIL, SEE DETAILS ON SHEET XX.
  - INSTALL SPLIT RAIL FENCE, SEE DETAILS ON SHEET XX.
  - INSTALL GRAVITY BLOCK WALL. SEE WALL DETAILS ON SHEET WD1. SEE WALL PROFILES ON WP SHEETS.
  - DRIVEWAY REMOVAL. SEE MP SHEETS FOR PLANTING PLAN.
  - INSTALL PATTERNED CONCRETE DRIVEWAY. SEE DETAILS ON SHEET XX.
  - INSTALL TYPE 1 REST STOP. SEE DETAILS ON SHEET XX.
  - INSTALL TYPE 2 REST STOP. SEE DETAILS ON SHEET XX.
  - INSTALL SOLDIER PILE WALL.
  - INSTALL GRAVITY BLOCK WALL.
  - INSTALL WING WALL, SEE FP SHEETS.
  - INSTALL EXTRUDED CURB PER WSDOT STD PLAN F-10.42-00.
  - REST STOP PULL-OUT.
  - STAIRS WILL BE ELIMINATED DURING CONSTRUCTION.
  - BRIDGES WILL BE REMOVED TO R/W LINE DURING CONSTRUCTION.
  - INSTALL ROCK WALL.

- STORMWATER CONSTRUCTION NOTES:**
- INFILTRATION TRENCH, SEE DETAIL 4 ON SHEET DD1.
  - UNDERDRAIN TRENCH, SEE DETAIL 5 ON SHEET DD1.
  - ROCK PAD, SEE DETAIL 2 ON SHEET DD1 AND WP SHEETS.
  - CONNECTION TO DRAINAGE STRUCTURE AND CLEANING EXISTING DRAINAGE STRUCTURE.
  - INSTALL UNDERDRAIN TRENCH CLEANOUT, SEE DETAIL 6 ON SHEET DD1.
  - INSTALL RECTANGULAR SLIP RESISTANT SOLID METAL COVER PER WSDOT STD DETAIL B-30.20-02.
  - CONCRETE HEADWALL, SEE DETAIL 1 ON SHEET DD1.
  - BASIC DISPERSION, SEE SHEET CS3.
  - QUARRY SPALL OUTFALL PROTECTION. SEE DETAIL 3 ON SHEET DD1.
  - ADJUST CATCH BASIN.

**LEGEND:**

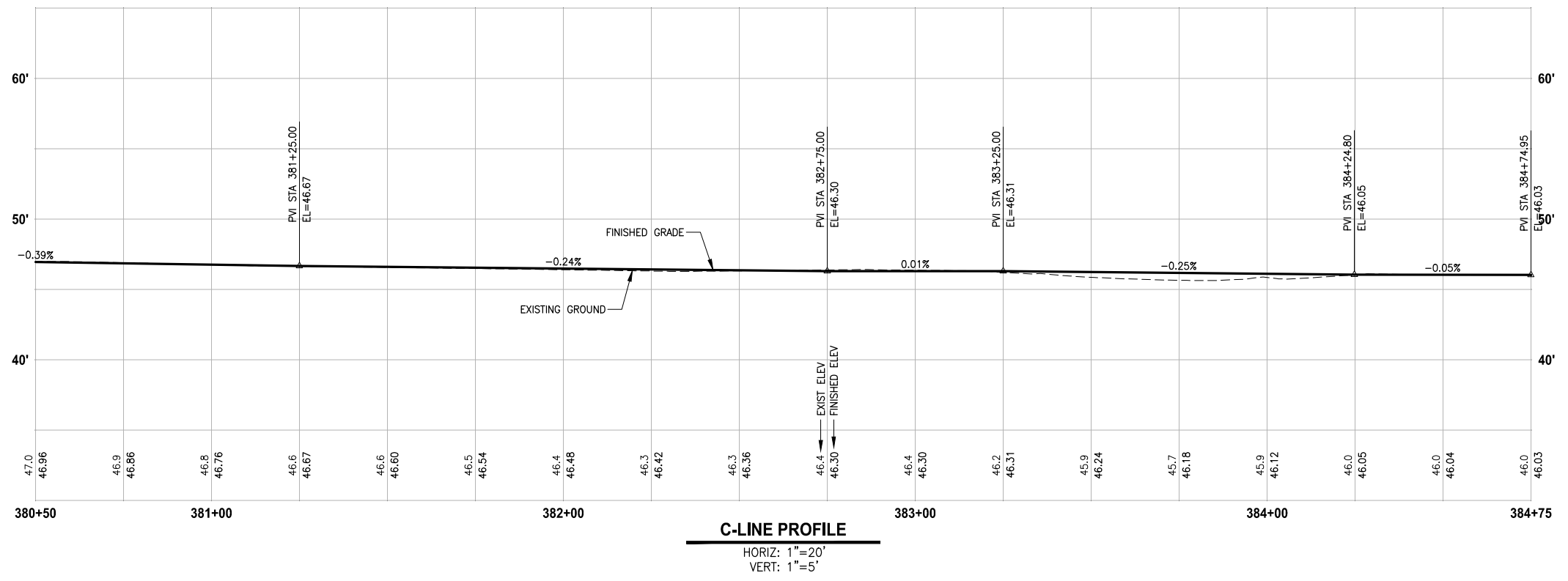
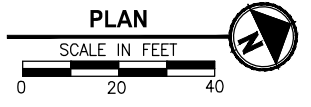
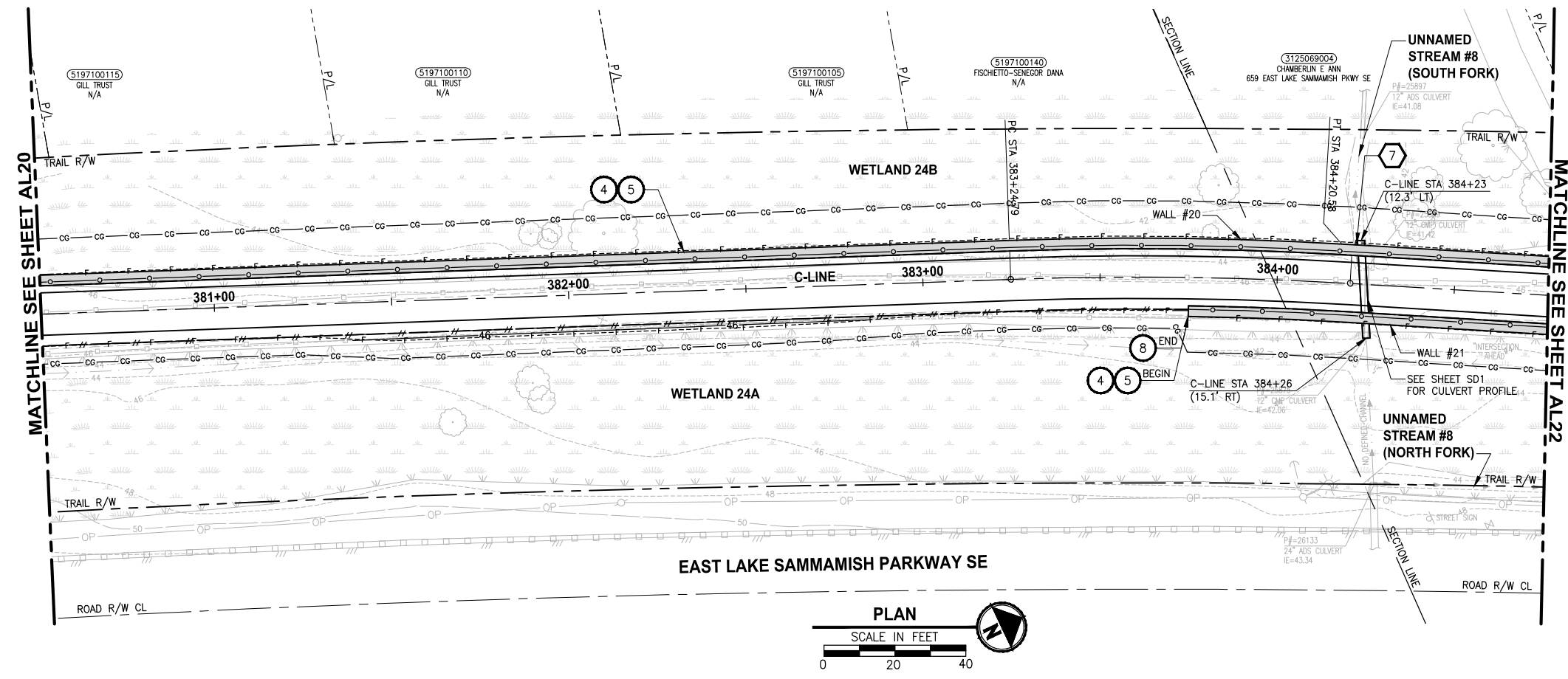
- RETAINING WALL
- SOLDIER PILE WALL
- WOOD GUARDRAIL
- DISPERSION AREA
- DRIVEWAY REMOVAL

CITY OF SAMMAMISH APPROVAL

City Engineer _____	Date _____
Community Development _____	Date _____

**60% REVIEW SUBMITTAL**  
 NOT FOR CONSTRUCTION

LAYOUT: AL21  
 PATH: U:\PSO\Projects\Clients\1521-KingCo\554-1521-075-ELST\995vcs\CADD\Phase 19\T03\_Civil\DWG\  
 PLOTTED BY: purgabul DATE: Wednesday, October 12, 2016 9:08:24 PM



- CIVIL CONSTRUCTION NOTES:**
- 1 RESTORE AND INSTALL STAIR. TYPE TO BE DETERMINED.
  - 2 RECONSTRUCT PEDESTRIAN BRIDGE.
  - 3 INSTALL PRECAST REINF CONC SPLIT BOX CULVERT. SEE FP SHEETS FOR DETAILS.
  - 4 INSTALL STRUCTURAL EARTH WALL. SEE WALL DETAILS ON SHEET X. SEE WALL PROFILES ON WP SHEETS.
  - 5 INSTALL COATED CHAIN LINK FENCE TYPE 6. FOR GROUND POST INSTALLATION SEE APPENDIX B IN THE SPECIFICATIONS. SEE SHEET X FOR MOUNTING ON TOP OF WALL.
  - 6 NEW DRIVEWAY.
  - 7 INSTALL WOOD GUARDRAIL, SEE DETAILS ON SHEET XX.
  - 8 INSTALL SPLIT RAIL FENCE, SEE DETAILS ON SHEET XX.
  - 9 INSTALL GRAVITY BLOCK WALL. SEE WALL DETAILS ON SHEET WD1. SEE WALL PROFILES ON WP SHEETS.
  - 10 DRIVEWAY REMOVAL. SEE MP SHEETS FOR PLANTING PLAN.
  - 11 INSTALL PATTERNED CONCRETE DRIVEWAY. SEE DETAILS ON SHEET XX.
  - 12 INSTALL TYPE 1 REST STOP. SEE DETAILS ON SHEET XX.
  - 13 INSTALL TYPE 2 REST STOP. SEE DETAILS ON SHEET XX.
  - 14 INSTALL SOLDIER PILE WALL.
  - 15 INSTALL GRAVITY BLOCK WALL.
  - 16 INSTALL WING WALL, SEE FP SHEETS.
  - 17 INSTALL EXTRUDED CURB PER WSDOT STD PLAN F-10.42-00.
  - 18 REST STOP PULL-OUT.
  - 19 STAIRS WILL BE ELIMINATED DURING CONSTRUCTION.
  - 20 BRIDGES WILL BE REMOVED TO R/W LINE DURING CONSTRUCTION.
  - 21 INSTALL ROCK WALL.

- STORMWATER CONSTRUCTION NOTES:**
- 1 INFILTRATION TRENCH, SEE DETAIL 4 ON SHEET DD1.
  - 2 UNDERDRAIN TRENCH, SEE DETAIL 5 ON SHEET DD1.
  - 3 ROCK PAD, SEE DETAIL 2 ON SHEET DD1 AND WP SHEETS.
  - 4 CONNECTION TO DRAINAGE STRUCTURE AND CLEANING EXISTING DRAINAGE STRUCTURE.
  - 5 INSTALL UNDERDRAIN TRENCH CLEANOUT, SEE DETAIL 6 ON SHEET DD1.
  - 6 INSTALL RECTANGULAR SLIP RESISTANT SOLID METAL COVER PER WSDOT STD DETAIL B-30.20-02.
  - 7 CONCRETE HEADWALL, SEE DETAIL 1 ON SHEET DD1.
  - 8 BASIC DISPERSION, SEE SHEET CS3.
  - 9 QUARRY SPALL OUTFALL PROTECTION. SEE DETAIL 3 ON SHEET DD1.
  - 10 ADJUST CATCH BASIN.

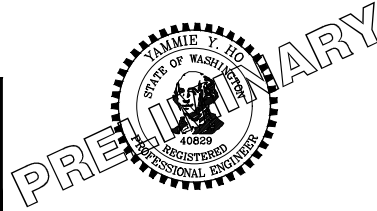
- LEGEND:**
- RETAINING WALL
  - SOLDIER PILE WALL
  - WOOD GUARDRAIL
  - DISPERSION AREA
  - DRIVEWAY REMOVAL

CITY OF SAMMAMISH APPROVAL	
City Engineer _____	Date _____
Community Development _____	Date _____

**60 % REVIEW SUBMITTAL  
NOT FOR CONSTRUCTION**

REVISIONS	DATE	BY	DESIGNED
			M. TSUN
			B. PURGANAN
			P. JOHANNESSEN
			Y. HO

**ONE INCH AT FULL SCALE,  
IF NOT, SCALE ACCORDINGLY**  
 FILE NAME: BL1521075P19T03AL-03  
 JOB No: 554-1521-075 P19 T03  
 DATE: SEPTEMBER 2016



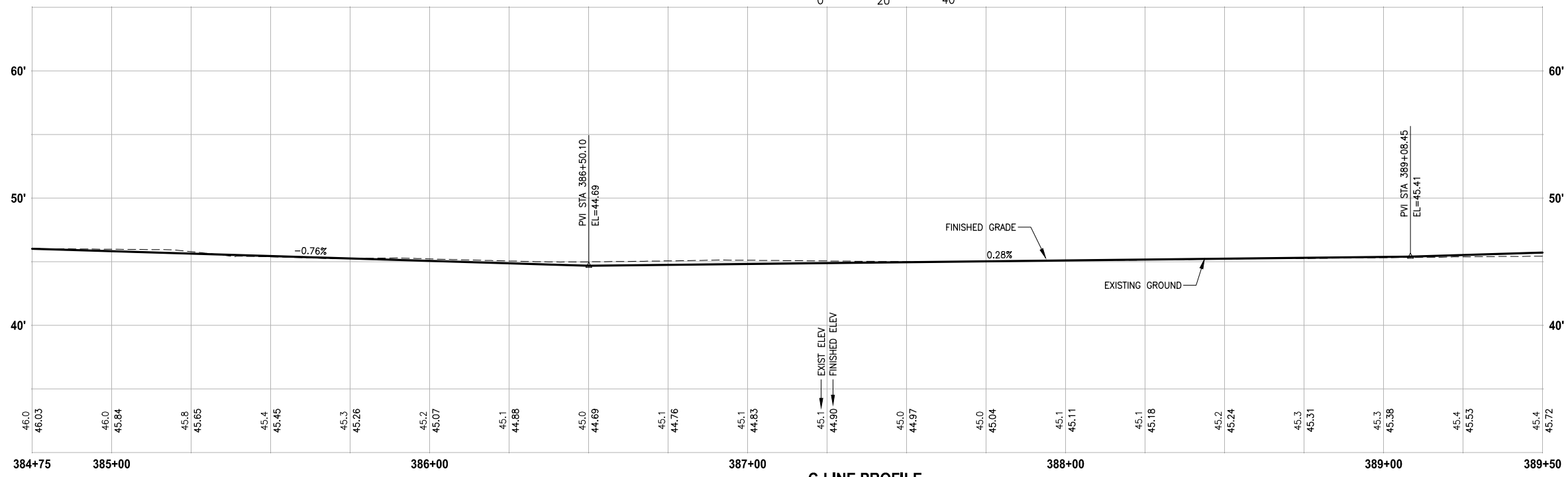
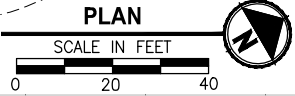
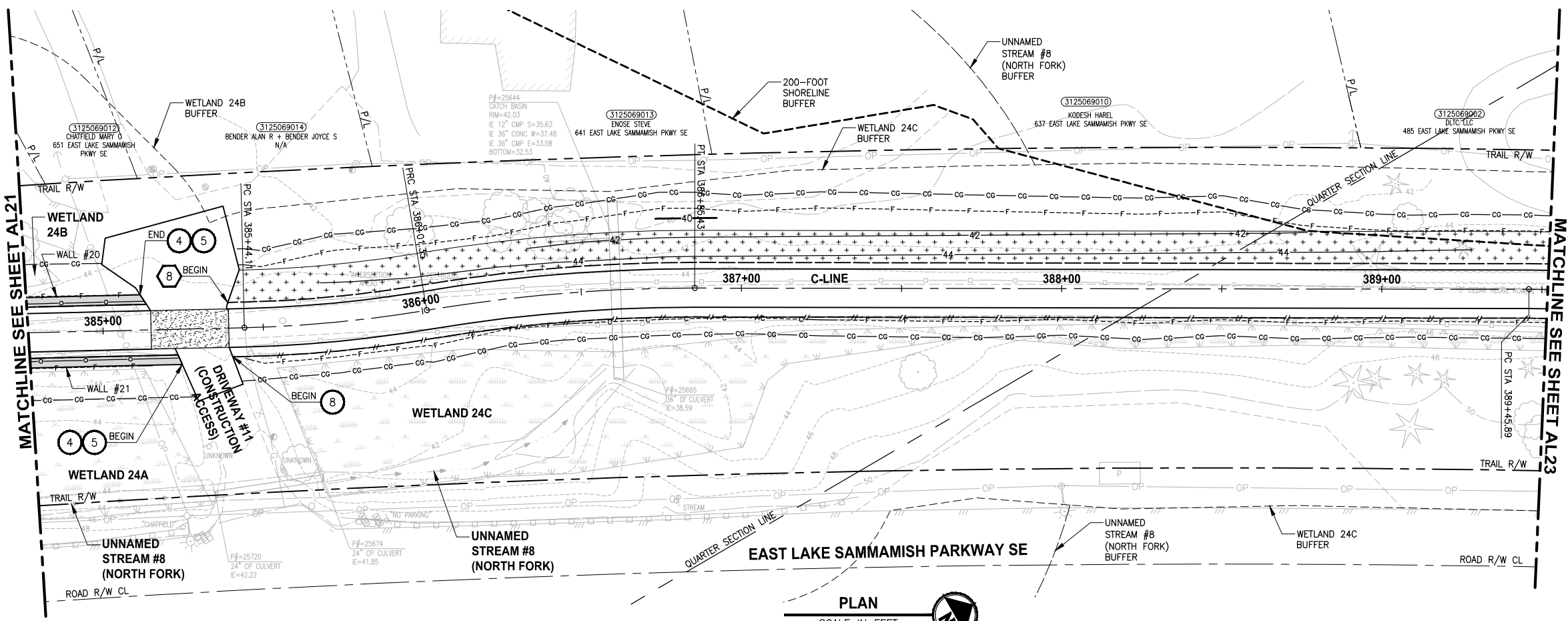
**Parametrix**  
 ENGINEERING · PLANNING · ENVIRONMENTAL SCIENCES  
 719 2ND AVENUE, SUITE 200 | SEATTLE, WA 98104  
 P 206.394.3700  
 WWW.PARAMETRIX.COM

PROJECT NAME  
**EAST LAKE SAMMAMISH  
MASTER PLAN TRAIL  
SOUTH SAMMAMISH SEGMENT B**  
 SAMMAMISH, WA

**PLAN AND PROFILE**

SHEET NO.  
 53 OF 135  
**AL21**

PATH: U:\PSO\Projects\Clients\1521-KingCo\554-1521-075-ELST\995sca\CaADD\Phase 19\103\_Civil\Draw\ PLOTTED BY: purgabut DATE: Wednesday, October 12, 2016 9:06:55 PM LAYOUT: AL22



**C-LINE PROFILE**  
HORIZ: 1"=20'  
VERT: 1"=5'

- CIVIL CONSTRUCTION NOTES:**
- 1 RESTORE AND INSTALL STAIR. TYPE TO BE DETERMINED.
  - 2 RECONSTRUCT PEDESTRIAN BRIDGE.
  - 3 INSTALL PRECAST REINF CONC SPLIT BOX CULVERT. SEE FP SHEETS FOR DETAILS.
  - 4 INSTALL STRUCTURAL EARTH WALL. SEE WALL DETAILS ON SHEET X. SEE WALL PROFILES ON WP SHEETS.
  - 5 INSTALL COATED CHAIN LINK FENCE TYPE 6. FOR GROUND POST INSTALLATION SEE APPENDIX B IN THE SPECIFICATIONS. SEE SHEET X FOR MOUNTING ON TOP OF WALL.
  - 6 NEW DRIVEWAY.
  - 7 INSTALL WOOD GUARDRAIL, SEE DETAILS ON SHEET XX.
  - 8 INSTALL SPLIT RAIL FENCE, SEE DETAILS ON SHEET XX.
  - 9 INSTALL GRAVITY BLOCK WALL. SEE WALL DETAILS ON SHEET WD1. SEE WALL PROFILES ON WP SHEETS.
  - 10 DRIVEWAY REMOVAL. SEE MP SHEETS FOR PLANTING PLAN.
  - 11 INSTALL PATTERNED CONCRETE DRIVEWAY. SEE DETAILS ON SHEET XX.
  - 12 INSTALL TYPE 1 REST STOP. SEE DETAILS ON SHEET XX.
  - 13 INSTALL TYPE 2 REST STOP. SEE DETAILS ON SHEET XX.
  - 14 INSTALL SOLDIER PILE WALL.
  - 15 INSTALL GRAVITY BLOCK WALL.
  - 16 INSTALL WING WALL, SEE FP SHEETS.
  - 17 INSTALL EXTRUDED CURB PER WSDOT STD PLAN F-10.42-00.
  - 18 REST STOP PULL-OUT.
  - 19 STAIRS WILL BE ELIMINATED DURING CONSTRUCTION.
  - 20 BRIDGES WILL BE REMOVED TO R/W LINE DURING CONSTRUCTION.
  - 21 INSTALL ROCK WALL.

- STORMWATER CONSTRUCTION NOTES:**
- 1 INFILTRATION TRENCH, SEE DETAIL 4 ON SHEET DD1.
  - 2 UNDERDRAIN TRENCH, SEE DETAIL 5 ON SHEET DD1.
  - 3 ROCK PAD, SEE DETAIL 2 ON SHEET DD1 AND WP SHEETS.
  - 4 CONNECTION TO DRAINAGE STRUCTURE AND CLEANING EXISTING DRAINAGE STRUCTURE.
  - 5 INSTALL UNDERDRAIN TRENCH CLEANOUT, SEE DETAIL 6 ON SHEET DD1.
  - 6 INSTALL RECTANGULAR SLIP RESISTANT SOLID METAL COVER PER WSDOT STD DETAIL B-30.20-02.
  - 7 CONCRETE HEADWALL, SEE DETAIL 1 ON SHEET DD1.
  - 8 BASIC DISPERSION, SEE SHEET CS3.
  - 9 QUARRY SPALL OUTFALL PROTECTION. SEE DETAIL 3 ON SHEET DD1.
  - 10 ADJUST CATCH BASIN.

- LEGEND:**
- RETAINING WALL
  - SOLDIER PILE WALL
  - WOOD GUARDRAIL
  - DISPERSION AREA
  - DRIVEWAY REMOVAL

**CITY OF SAMMAMISH APPROVAL**

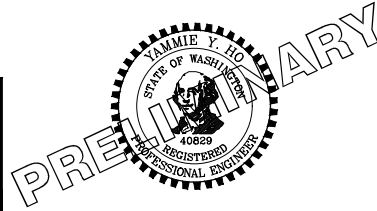
City Engineer _____	Date _____
Community Development _____	Date _____

**60% REVIEW SUBMITTAL**  
NOT FOR CONSTRUCTION

REVISIONS	DATE	BY	DESIGNED
			M. TSUN
			B. PURGANAN
			P. JOHANNESSEN
			Y. HO

**ONE INCH AT FULL SCALE, IF NOT, SCALE ACCORDINGLY**

FILE NAME: BL1521075P19T03AL-03  
JOB No: 554-1521-075 P19 T03  
DATE: SEPTEMBER 2016



**Parametrix**  
ENGINEERING · PLANNING · ENVIRONMENTAL SCIENCES

719 2ND AVENUE, SUITE 200 | SEATTLE, WA 98104  
P 206.394.3700  
WWW.PARAMETRIX.COM

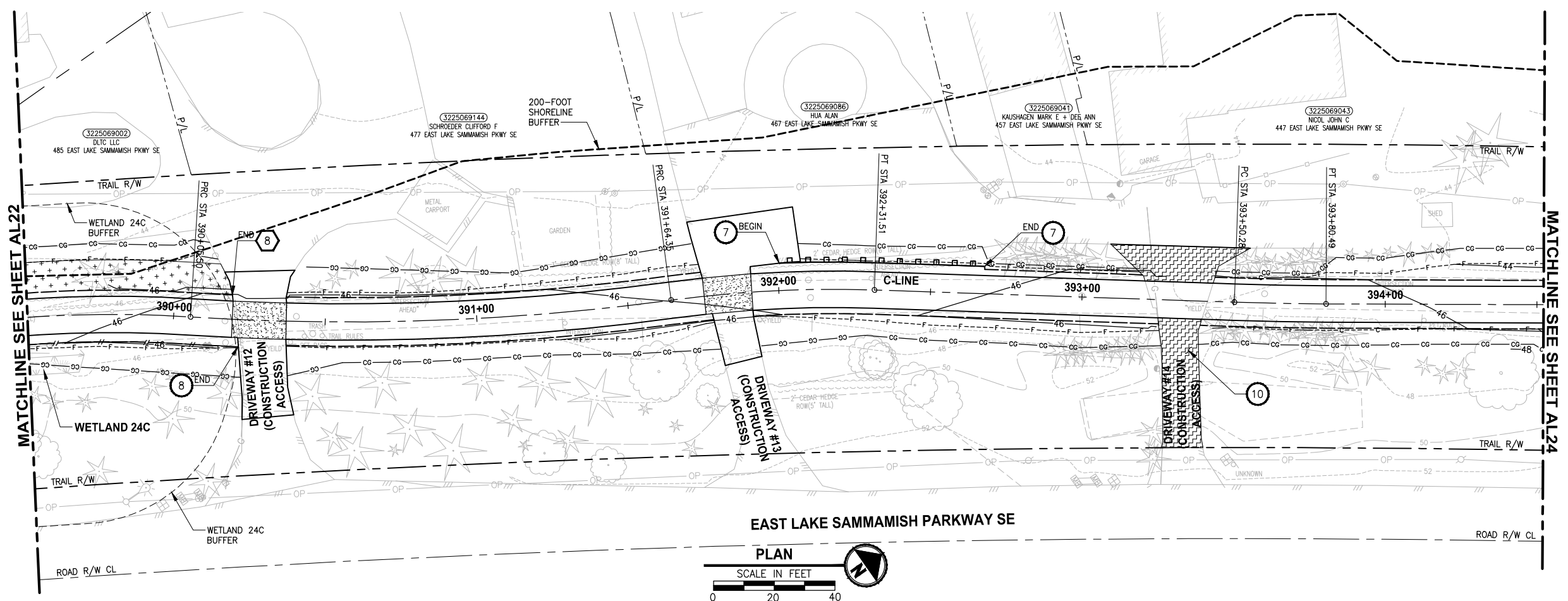
PROJECT NAME  
**EAST LAKE SAMMAMISH MASTER PLAN TRAIL SOUTH SAMMAMISH SEGMENT B**  
SAMMAMISH, WA

**PLAN AND PROFILE**

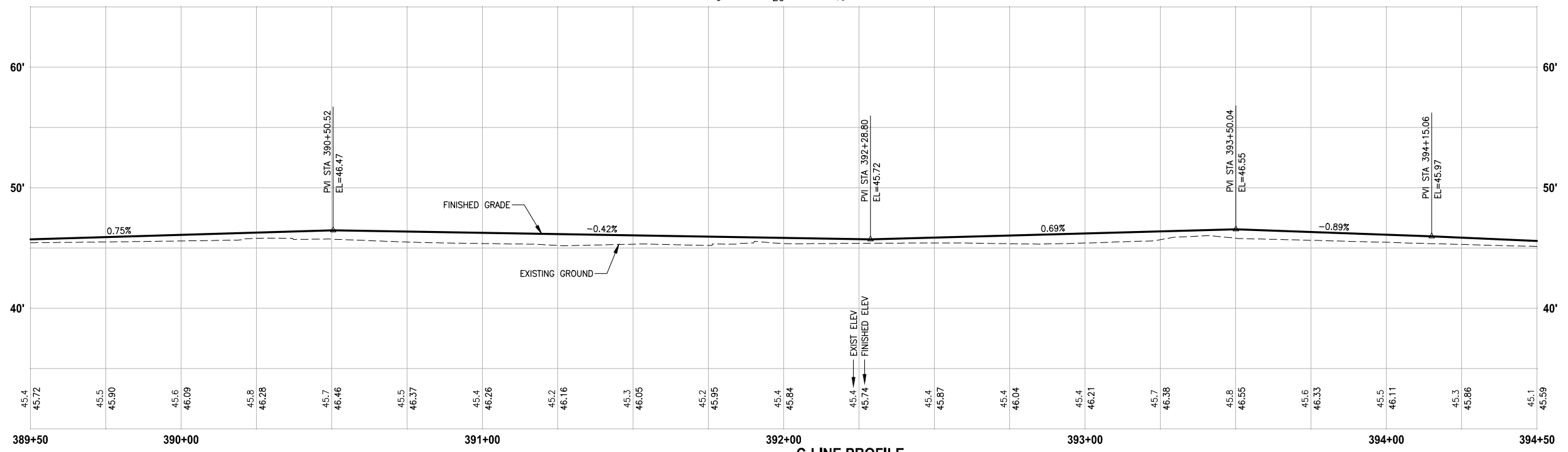
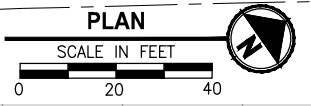
SHEET NO.  
54 OF 135  
**AL22**



LAYOUT: AL23  
 PATH: U:\PSO\Projects\Clients\1521-075-ELST\995003\CaDD\Phase 19\103\_Civil\Draw\ PLOTTED BY: purgabub DATE: Wednesday, October 12, 2016 9:09:22 PM



**EAST LAKE SAMMAMISH PARKWAY SE**



**C-LINE PROFILE**

HORIZ: 1"=20'  
VERT: 1"=5'

**CIVIL CONSTRUCTION NOTES:**

- 1 RESTORE AND INSTALL STAIR. TYPE TO BE DETERMINED.
- 2 RECONSTRUCT PEDESTRIAN BRIDGE.
- 3 INSTALL PRECAST REINF CONC SPLIT BOX CULVERT. SEE FP SHEETS FOR DETAILS.
- 4 INSTALL STRUCTURAL EARTH WALL. SEE WALL DETAILS ON SHEET X. SEE WALL PROFILES ON WP SHEETS.
- 5 INSTALL COATED CHAIN LINK FENCE TYPE 6. FOR GROUND POST INSTALLATION SEE APPENDIX B IN THE SPECIFICATIONS. SEE SHEET X FOR MOUNTING ON TOP OF WALL.
- 6 NEW DRIVEWAY.
- 7 INSTALL WOOD GUARDRAIL, SEE DETAILS ON SHEET XX.
- 8 INSTALL SPLIT RAIL FENCE, SEE DETAILS ON SHEET XX.
- 9 INSTALL GRAVITY BLOCK WALL. SEE WALL DETAILS ON SHEET WD1. SEE WALL PROFILES ON WP SHEETS.
- 10 DRIVEWAY REMOVAL. SEE MP SHEETS FOR PLANTING PLAN.
- 11 INSTALL PATTERNED CONCRETE DRIVEWAY. SEE DETAILS ON SHEET XX.
- 12 INSTALL TYPE 1 REST STOP. SEE DETAILS ON SHEET XX.
- 13 INSTALL TYPE 2 REST STOP. SEE DETAILS ON SHEET XX.
- 14 INSTALL SOLDIER PILE WALL.
- 15 INSTALL GRAVITY BLOCK WALL.
- 16 INSTALL WING WALL, SEE FP SHEETS.
- 17 INSTALL EXTRUDED CURB PER WSDOT STD PLAN F-10.42-00.
- 18 REST STOP PULL-OUT.
- 19 STAIRS WILL BE ELIMINATED DURING CONSTRUCTION.
- 20 BRIDGES WILL BE REMOVED TO R/W LINE DURING CONSTRUCTION.
- 21 INSTALL ROCK WALL.

**STORMWATER CONSTRUCTION NOTES:**

- 1 INFILTRATION TRENCH, SEE DETAIL 4 ON SHEET DD1.
- 2 UNDERDRAIN TRENCH, SEE DETAIL 5 ON SHEET DD1.
- 3 ROCK PAD, SEE DETAIL 2 ON SHEET DD1 AND WP SHEETS.
- 4 CONNECTION TO DRAINAGE STRUCTURE AND CLEANING EXISTING DRAINAGE STRUCTURE.
- 5 INSTALL UNDERDRAIN TRENCH CLEANOUT, SEE DETAIL 6 ON SHEET DD1.
- 6 INSTALL RECTANGULAR SLIP RESISTANT SOLID METAL COVER PER WSDOT STD DETAIL B-30.20-02.
- 7 CONCRETE HEADWALL, SEE DETAIL 1 ON SHEET DD1.
- 8 BASIC DISPERSION, SEE SHEET CS3.
- 9 QUARRY SPALL OUTFALL PROTECTION. SEE DETAIL 3 ON SHEET DD1.
- 10 ADJUST CATCH BASIN.

**LEGEND:**

- RETAINING WALL
- SOLDIER PILE WALL
- WOOD GUARDRAIL
- DISPERSION AREA
- DRIVEWAY REMOVAL

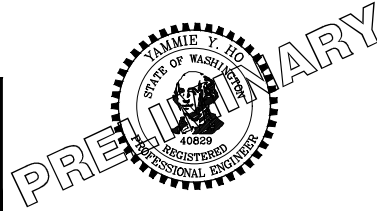
CITY OF SAMMAMISH APPROVAL	
City Engineer _____	Date _____
Community Development _____	Date _____

**60 % REVIEW SUBMITTAL  
NOT FOR CONSTRUCTION**

REVISIONS	DATE	BY	DESIGNED
			M. TSUN
			B. PURGANAN
			P. JOHANNESSEN
			Y. HO

ONE INCH AT FULL SCALE.  
IF NOT, SCALE ACCORDINGLY

FILE NAME: BL1521075P19T03AL-03  
JOB No.: 554-1521-075 P19 T03  
DATE: SEPTEMBER 2016



**Parametrix**  
ENGINEERING · PLANNING · ENVIRONMENTAL SCIENCES

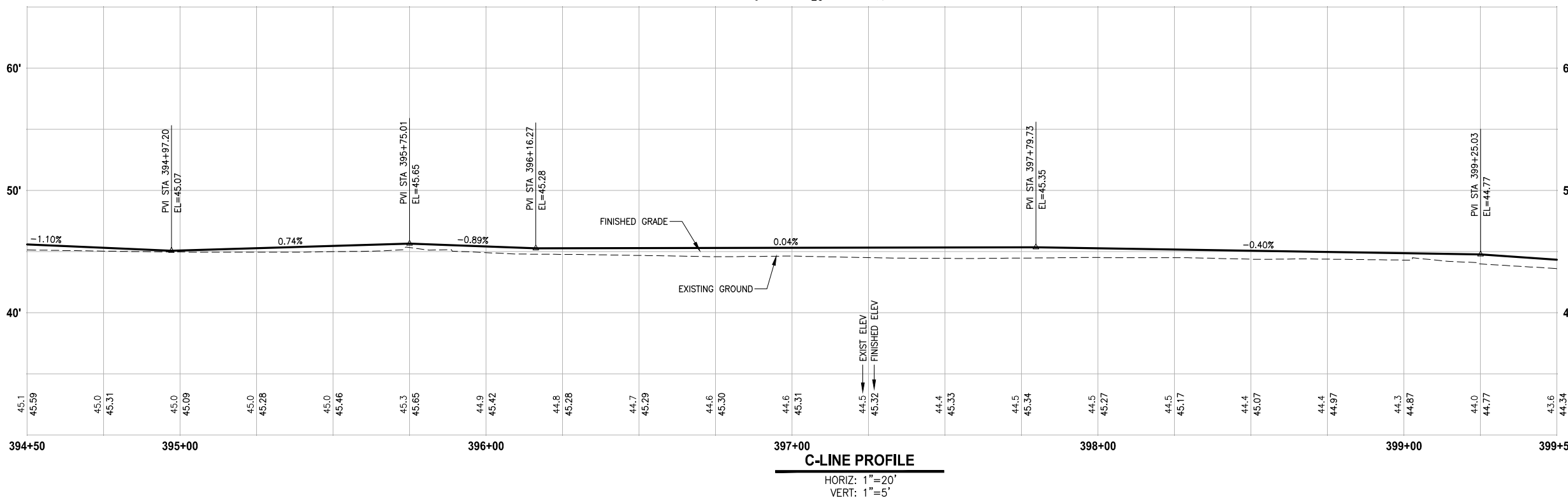
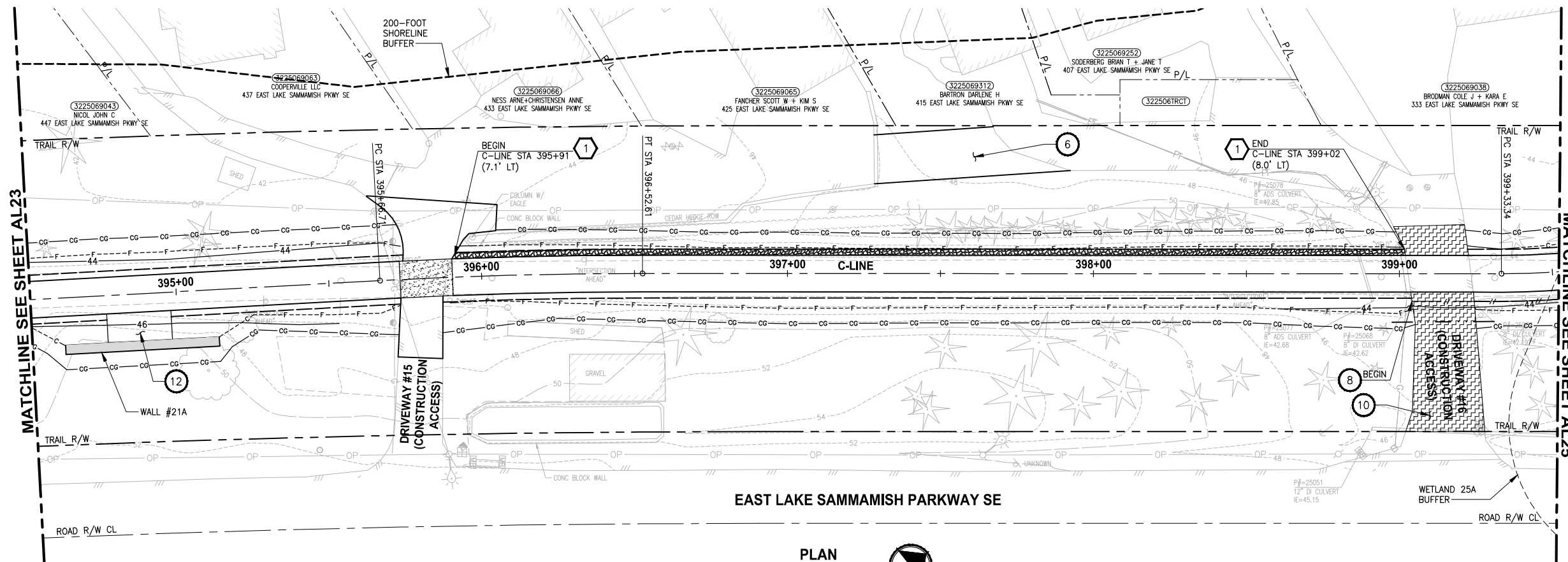
719 2ND AVENUE, SUITE 200 | SEATTLE, WA 98104  
P 206.394.3700  
WWW.PARAMETRIX.COM

PROJECT NAME  
**EAST LAKE SAMMAMISH  
MASTER PLAN TRAIL  
SOUTH SAMMAMISH SEGMENT B**  
SAMMAMISH, WA

**PLAN AND PROFILE**

SHEET NO.  
55 OF 135  
**AL23**

LAYOUT: AL24  
 PATH: U:\PSO\Projects\Clients\1521-KingCo\554-1521-075-ELST\995sca\CaDD\Phase 19\103\_Civil\Draw\ PLOTTED BY: purgabut DATE: Wednesday, October 12, 2016 9:09:55 PM



**CIVIL CONSTRUCTION NOTES:**

- 1 RESTORE AND INSTALL STAIR. TYPE TO BE DETERMINED.
- 2 RECONSTRUCT PEDESTRIAN BRIDGE.
- 3 INSTALL PRECAST REINF CONC SPLIT BOX CULVERT. SEE FP SHEETS FOR DETAILS.
- 4 INSTALL STRUCTURAL EARTH WALL. SEE WALL DETAILS ON SHEET X. SEE WALL PROFILES ON WP SHEETS.
- 5 INSTALL COATED CHAIN LINK FENCE TYPE 6. FOR GROUND POST INSTALLATION SEE APPENDIX B IN THE SPECIFICATIONS. SEE SHEET X FOR MOUNTING ON TOP OF WALL.
- 6 NEW DRIVEWAY.
- 7 INSTALL WOOD GUARDRAIL, SEE DETAILS ON SHEET XX.
- 8 INSTALL SPLIT RAIL FENCE, SEE DETAILS ON SHEET XX.
- 9 INSTALL GRAVITY BLOCK WALL. SEE WALL DETAILS ON SHEET WD1. SEE WALL PROFILES ON WP SHEETS.
- 10 DRIVEWAY REMOVAL. SEE MP SHEETS FOR PLANTING PLAN.
- 11 INSTALL PATTERNED CONCRETE DRIVEWAY. SEE DETAILS ON SHEET XX.
- 12 INSTALL TYPE 1 REST STOP. SEE DETAILS ON SHEET XX.
- 13 INSTALL TYPE 2 REST STOP. SEE DETAILS ON SHEET XX.
- 14 INSTALL SOLDIER PILE WALL.
- 15 INSTALL GRAVITY BLOCK WALL.
- 16 INSTALL WING WALL, SEE FP SHEETS.
- 17 INSTALL EXTRUDED CURB PER WSDOT STD PLAN F-10.42-00.
- 18 REST STOP PULL-OUT.
- 19 STAIRS WILL BE ELIMINATED DURING CONSTRUCTION.
- 20 BRIDGES WILL BE REMOVED TO R/W LINE DURING CONSTRUCTION.
- 21 INSTALL ROCK WALL.

**STORMWATER CONSTRUCTION NOTES:**

- 1 INFILTRATION TRENCH, SEE DETAIL 4 ON SHEET DD1.
- 2 UNDERDRAIN TRENCH, SEE DETAIL 5 ON SHEET DD1.
- 3 ROCK PAD, SEE DETAIL 2 ON SHEET DD1 AND WP SHEETS.
- 4 CONNECTION TO DRAINAGE STRUCTURE AND CLEANING EXISTING DRAINAGE STRUCTURE.
- 5 INSTALL UNDERDRAIN TRENCH CLEANOUT, SEE DETAIL 6 ON SHEET DD1.
- 6 INSTALL RECTANGULAR SLIP RESISTANT SOLID METAL COVER PER WSDOT STD DETAIL B-30.20-02.
- 7 CONCRETE HEADWALL, SEE DETAIL 1 ON SHEET DD1.
- 8 BASIC DISPERSION, SEE SHEET CS3.
- 9 QUARRY SPALL OUTFALL PROTECTION. SEE DETAIL 3 ON SHEET DD1.
- 10 ADJUST CATCH BASIN.

**LEGEND:**

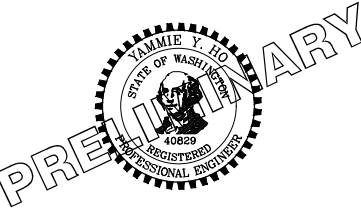
- RETAINING WALL
- SOLDIER PILE WALL
- WOOD GUARDRAIL
- DISPERSION AREA
- DRIVEWAY REMOVAL

CITY OF SAMMAMISH APPROVAL	
City Engineer _____	Date _____
Community Development _____	Date _____

**60 % REVIEW SUBMITTAL  
NOT FOR CONSTRUCTION**

REVISIONS	DATE	BY	DESIGNED
			M. TSUN
			B. PURGANAN
			P. JOHANNESSEN
			Y. HO

**ONE INCH AT FULL SCALE,  
IF NOT, SCALE ACCORDINGLY**  
 FILE NAME: BL1521075P19T03AL-03  
 JOB No.: 554-1521-075 P19 T03  
 DATE: SEPTEMBER 2016

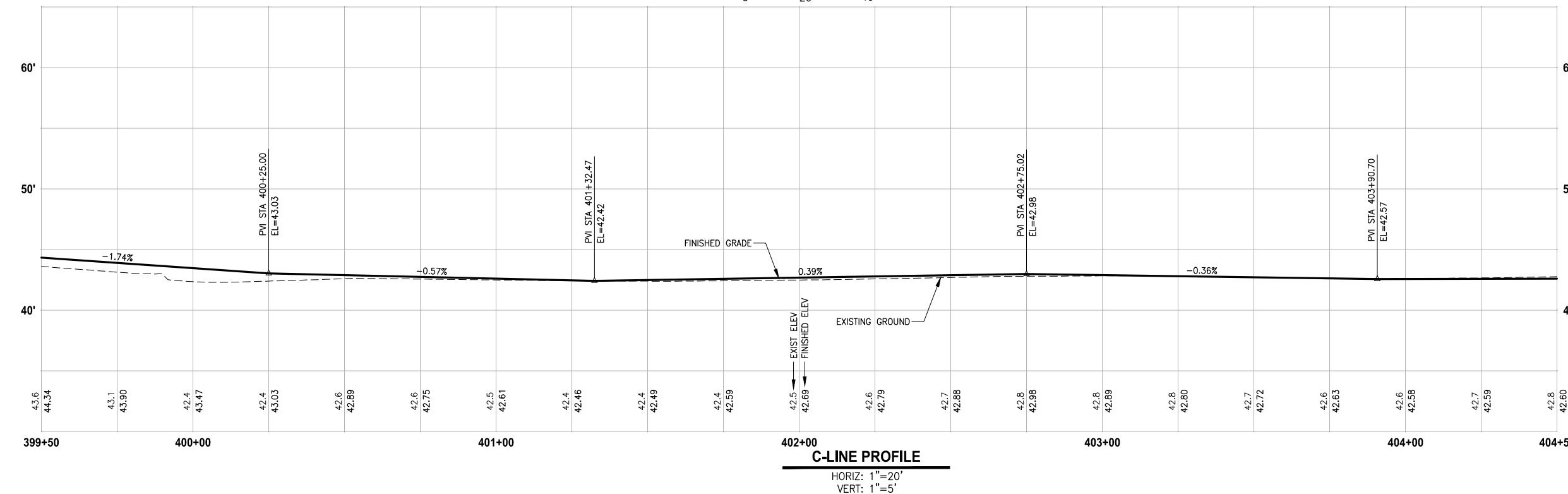
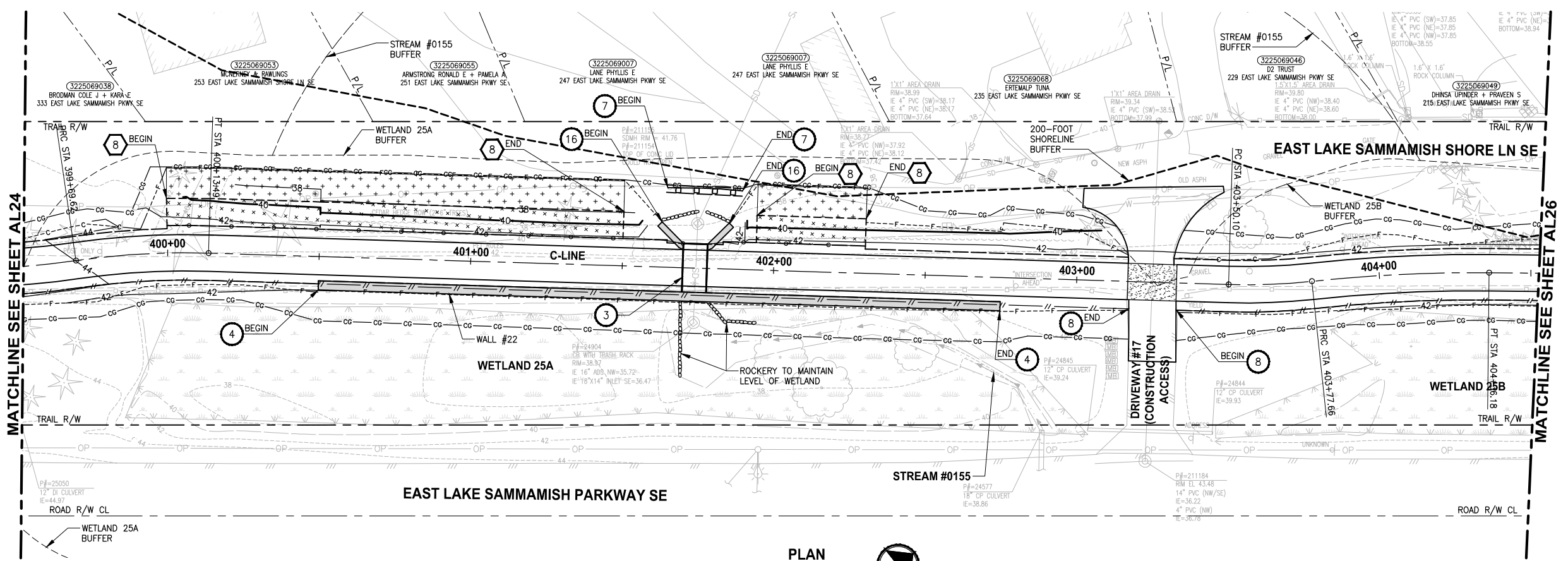


**Parametrix**  
 ENGINEERING · PLANNING · ENVIRONMENTAL SCIENCES  
 719 2ND AVENUE, SUITE 200 | SEATTLE, WA 98104  
 P 206.394.3700  
 WWW.PARAMETRIX.COM

PROJECT NAME  
**EAST LAKE SAMMAMISH  
MASTER PLAN TRAIL  
SOUTH SAMMAMISH SEGMENT B**  
 SAMMAMISH, WA

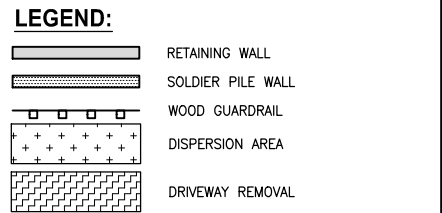
**PLAN AND PROFILE**  
 SHEET NO.  
56 OF 135  
**AL24**

LAYOUT: AL25  
 PATH: U:\FSO\Projects\Clients\1521-075-ELST\99503\CaDD\Phase 19\T03\_Civil\Draw\ PLOTTED BY: purgabut DATE: Wednesday, October 12, 2016 9:10:22 PM



- CIVIL CONSTRUCTION NOTES:**
- RESTORE AND INSTALL STAIR. TYPE TO BE DETERMINED.
  - RECONSTRUCT PEDESTRIAN BRIDGE.
  - INSTALL PRECAST REINF CONC SPLIT BOX CULVERT. SEE FP SHEETS FOR DETAILS.
  - INSTALL STRUCTURAL EARTH WALL. SEE WALL DETAILS ON SHEET X. SEE WALL PROFILES ON WP SHEETS.
  - INSTALL COATED CHAIN LINK FENCE TYPE 6. FOR GROUND POST INSTALLATION SEE APPENDIX B IN THE SPECIFICATIONS. SEE SHEET X FOR MOUNTING ON TOP OF WALL.
  - NEW DRIVEWAY.
  - INSTALL WOOD GUARDRAIL, SEE DETAILS ON SHEET XX.
  - INSTALL SPLIT RAIL FENCE, SEE DETAILS ON SHEET XX.
  - INSTALL GRAVITY BLOCK WALL. SEE WALL DETAILS ON SHEET WD1. SEE WALL PROFILES ON WP SHEETS.
  - DRIVEWAY REMOVAL. SEE MP SHEETS FOR PLANTING PLAN.
  - INSTALL PATTERNED CONCRETE DRIVEWAY. SEE DETAILS ON SHEET XX.
  - INSTALL TYPE 1 REST STOP. SEE DETAILS ON SHEET XX.
  - INSTALL TYPE 2 REST STOP. SEE DETAILS ON SHEET XX.
  - INSTALL SOLDIER PILE WALL.
  - INSTALL GRAVITY BLOCK WALL.
  - INSTALL WING WALL, SEE FP SHEETS.
  - INSTALL EXTRUDED CURB PER WSDOT STD PLAN F-10.42-00.
  - REST STOP PULL-OUT.
  - STAIRS WILL BE ELIMINATED DURING CONSTRUCTION.
  - BRIDGES WILL BE REMOVED TO R/W LINE DURING CONSTRUCTION.
  - INSTALL ROCK WALL.

- STORMWATER CONSTRUCTION NOTES:**
- INFILTRATION TRENCH, SEE DETAIL 4 ON SHEET DD1.
  - UNDERDRAIN TRENCH, SEE DETAIL 5 ON SHEET DD1.
  - ROCK PAD, SEE DETAIL 2 ON SHEET DD1 AND WP SHEETS.
  - CONNECTION TO DRAINAGE STRUCTURE AND CLEANING EXISTING DRAINAGE STRUCTURE.
  - INSTALL UNDERDRAIN TRENCH CLEANOUT, SEE DETAIL 6 ON SHEET DD1.
  - INSTALL RECTANGULAR SLIP RESISTANT SOLID METAL COVER PER WSDOT STD DETAIL B-30.20-02.
  - CONCRETE HEADWALL, SEE DETAIL 1 ON SHEET DD1.
  - BASIC DISPERSION, SEE SHEET CS3.
  - QUARRY SPALL OUTFALL PROTECTION. SEE DETAIL 3 ON SHEET DD1.
  - ADJUST CATCH BASIN.



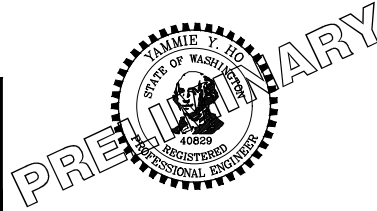
**CITY OF SAMMAMISH APPROVAL**

City Engineer	Date
Community Development	Date

**60% REVIEW SUBMITTAL**  
NOT FOR CONSTRUCTION

REVISIONS	DATE	BY	DESIGNED
			M. TSUN
			B. PURGANAN
			P. JOHANNESSEN
			Y. HO

**ONE INCH AT FULL SCALE, IF NOT, SCALE ACCORDINGLY**  
 FILE NAME: BL1521075P19T03AL-03  
 JOB No: 554-1521-075 P19 T03  
 DATE: SEPTEMBER 2016



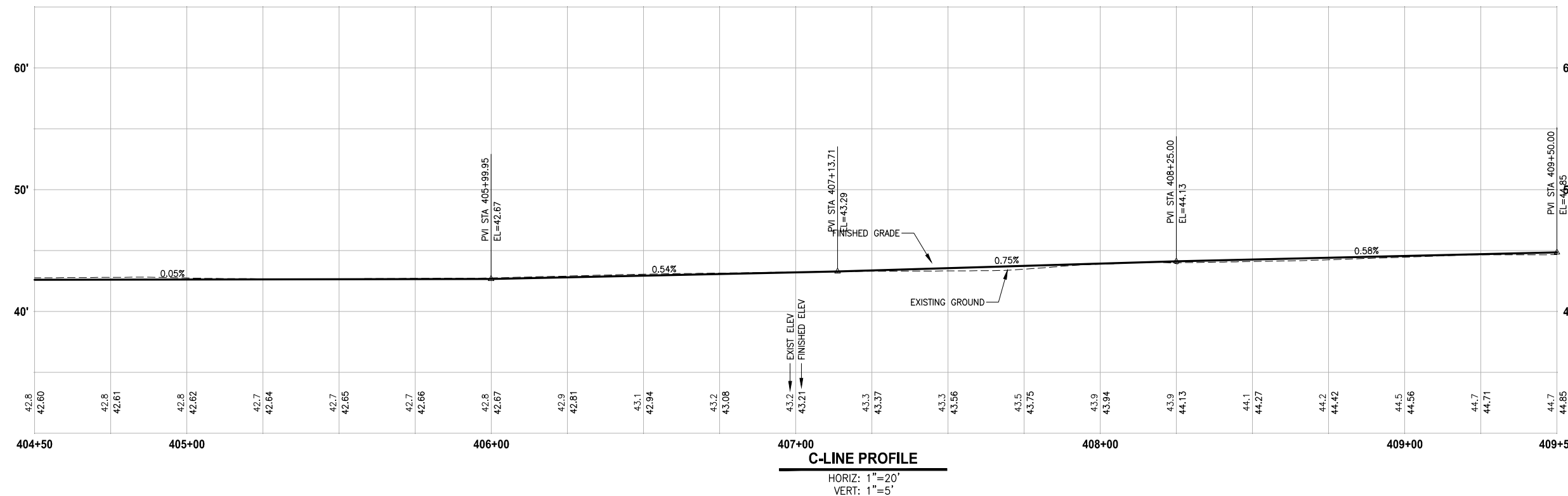
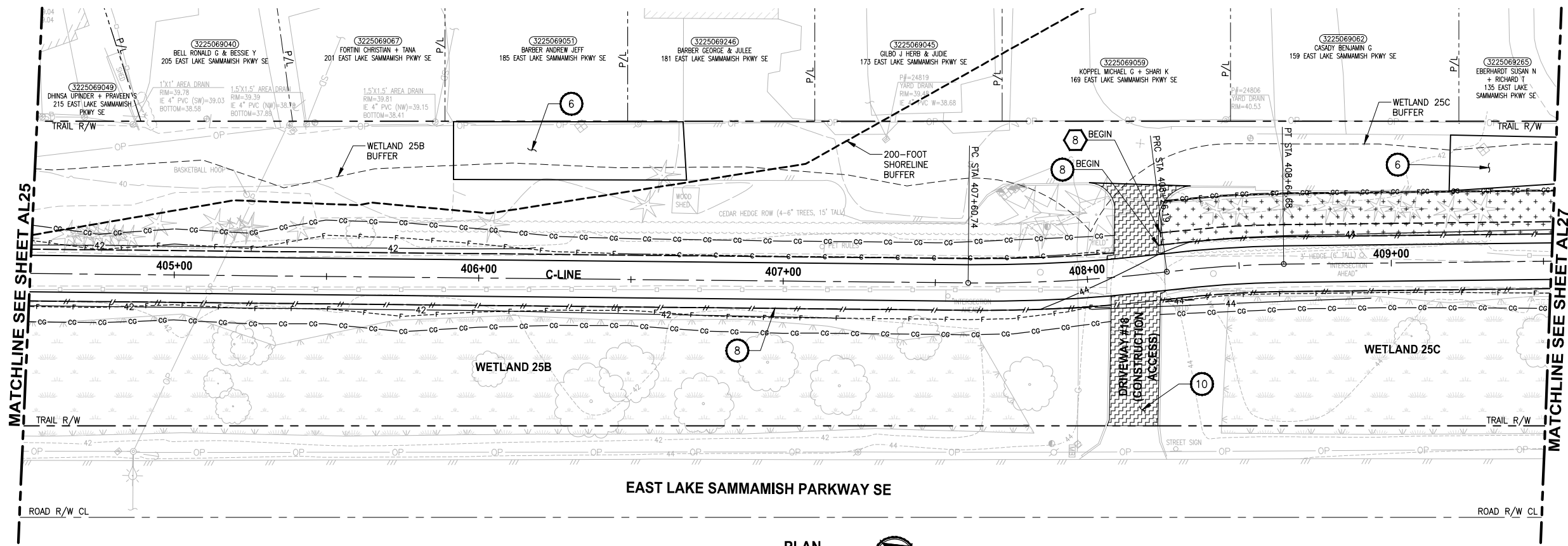
**Parametrix**  
 ENGINEERING · PLANNING · ENVIRONMENTAL SCIENCES  
 719 2ND AVENUE, SUITE 200 | SEATTLE, WA 98104  
 P 206.394.3700  
 WWW.PARAMETRIX.COM

PROJECT NAME  
**EAST LAKE SAMMAMISH MASTER PLAN TRAIL SOUTH SAMMAMISH SEGMENT B**  
 SAMMAMISH, WA

**PLAN AND PROFILE**  
 SHEET NO. 57 OF 135  
**AL25**



LAYOUT: AL26  
 PATH: U:\PSO\Projects\Clients\1521-KingCo\554-1521-075-ELST\995sca\CaDD\Phase 19\T03\_Civil\Draw\ PLOTTED BY: purgaban DATE: Wednesday, October 12, 2016 9:10:55 PM



- CIVIL CONSTRUCTION NOTES:**
- 1 RESTORE AND INSTALL STAIR. TYPE TO BE DETERMINED.
  - 2 RECONSTRUCT PEDESTRIAN BRIDGE.
  - 3 INSTALL PRECAST REINF CONC SPLIT BOX CULVERT. SEE FP SHEETS FOR DETAILS.
  - 4 INSTALL STRUCTURAL EARTH WALL. SEE WALL DETAILS ON SHEET X. SEE WALL PROFILES ON WP SHEETS.
  - 5 INSTALL COATED CHAIN LINK FENCE TYPE 6. FOR GROUND POST INSTALLATION SEE APPENDIX B IN THE SPECIFICATIONS. SEE SHEET X FOR MOUNTING ON TOP OF WALL.
  - 6 NEW DRIVEWAY.
  - 7 INSTALL WOOD GUARDRAIL, SEE DETAILS ON SHEET XX.
  - 8 INSTALL SPLIT RAIL FENCE, SEE DETAILS ON SHEET XX.
  - 9 INSTALL GRAVITY BLOCK WALL. SEE WALL DETAILS ON SHEET WD1. SEE WALL PROFILES ON WP SHEETS.
  - 10 DRIVEWAY REMOVAL. SEE MP SHEETS FOR PLANTING PLAN.
  - 11 INSTALL PATTERNED CONCRETE DRIVEWAY. SEE DETAILS ON SHEET XX.
  - 12 INSTALL TYPE 1 REST STOP. SEE DETAILS ON SHEET XX.
  - 13 INSTALL TYPE 2 REST STOP. SEE DETAILS ON SHEET XX.
  - 14 INSTALL SOLDIER PILE WALL.
  - 15 INSTALL GRAVITY BLOCK WALL.
  - 16 INSTALL WING WALL. SEE FP SHEETS.
  - 17 INSTALL EXTRUDED CURB PER WSDOT STD PLAN F-10.42-00.
  - 18 REST STOP PULL-OUT.
  - 19 STAIRS WILL BE ELIMINATED DURING CONSTRUCTION.
  - 20 BRIDGES WILL BE REMOVED TO R/W LINE DURING CONSTRUCTION.
  - 21 INSTALL ROCK WALL.

- STORMWATER CONSTRUCTION NOTES:**
- 1 INFILTRATION TRENCH, SEE DETAIL 4 ON SHEET DD1.
  - 2 UNDERDRAIN TRENCH, SEE DETAIL 5 ON SHEET DD1.
  - 3 ROCK PAD, SEE DETAIL 2 ON SHEET DD1 AND WP SHEETS.
  - 4 CONNECTION TO DRAINAGE STRUCTURE AND CLEANING EXISTING DRAINAGE STRUCTURE.
  - 5 INSTALL UNDERDRAIN TRENCH CLEANOUT, SEE DETAIL 6 ON SHEET DD1.
  - 6 INSTALL RECTANGULAR SLIP RESISTANT SOLID METAL COVER PER WSDOT STD DETAIL B-30.20-02.
  - 7 CONCRETE HEADWALL, SEE DETAIL 1 ON SHEET DD1.
  - 8 BASIC DISPERSION, SEE SHEET CS3.
  - 9 QUARRY SPALL OUTFALL PROTECTION. SEE DETAIL 3 ON SHEET DD1.
  - 10 ADJUST CATCH BASIN.

- LEGEND:**
- RETAINING WALL
  - SOLDIER PILE WALL
  - WOOD GUARDRAIL
  - DISPERSION AREA
  - DRIVEWAY REMOVAL

**CITY OF SAMMAMISH APPROVAL**

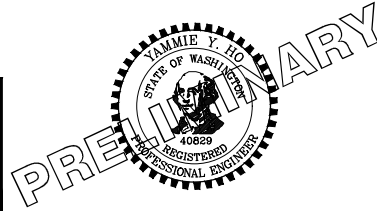
City Engineer _____	Date _____
Community Development _____	Date _____

**60% REVIEW SUBMITTAL**  
NOT FOR CONSTRUCTION

REVISIONS	DATE	BY	DESIGNED
			M. TSUN
			B. PURGANAN
			P. JOHANNESSEN
			Y. HO

**ONE INCH AT FULL SCALE, IF NOT, SCALE ACCORDINGLY**

FILE NAME: BL1521075P19T03AL-03  
 JOB No.: 554-1521-075 P19 T03  
 DATE: SEPTEMBER 2016



**Parametrix**  
ENGINEERING · PLANNING · ENVIRONMENTAL SCIENCES

719 2ND AVENUE, SUITE 200 | SEATTLE, WA 98104  
 P 206.394.3700  
 WWW.PARAMETRIX.COM

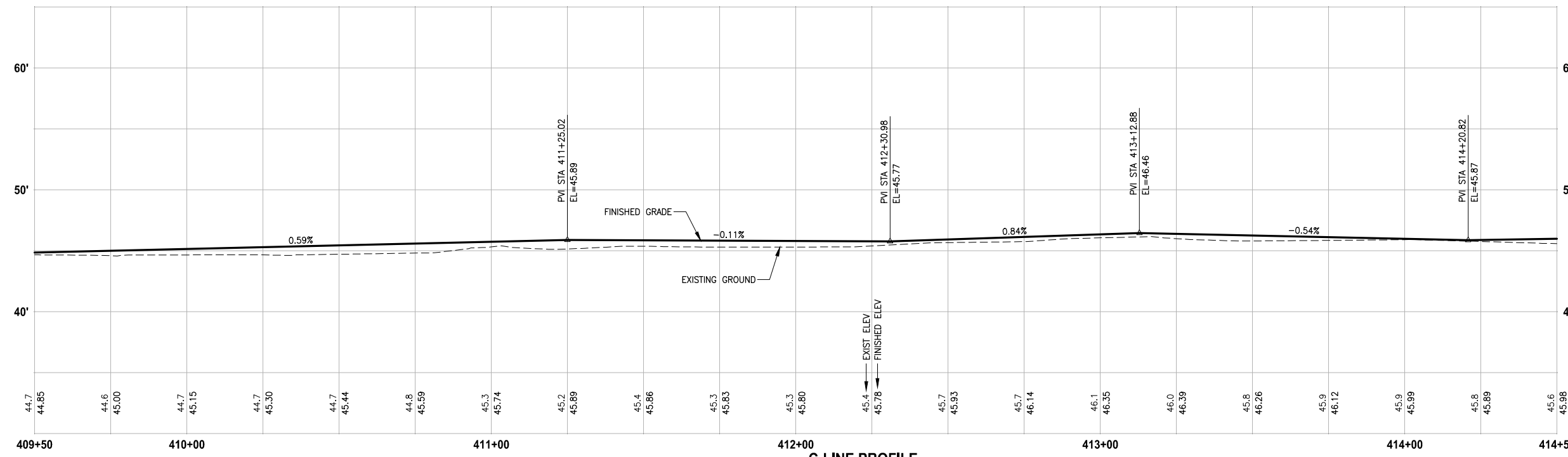
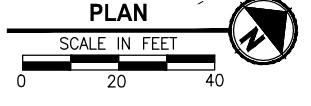
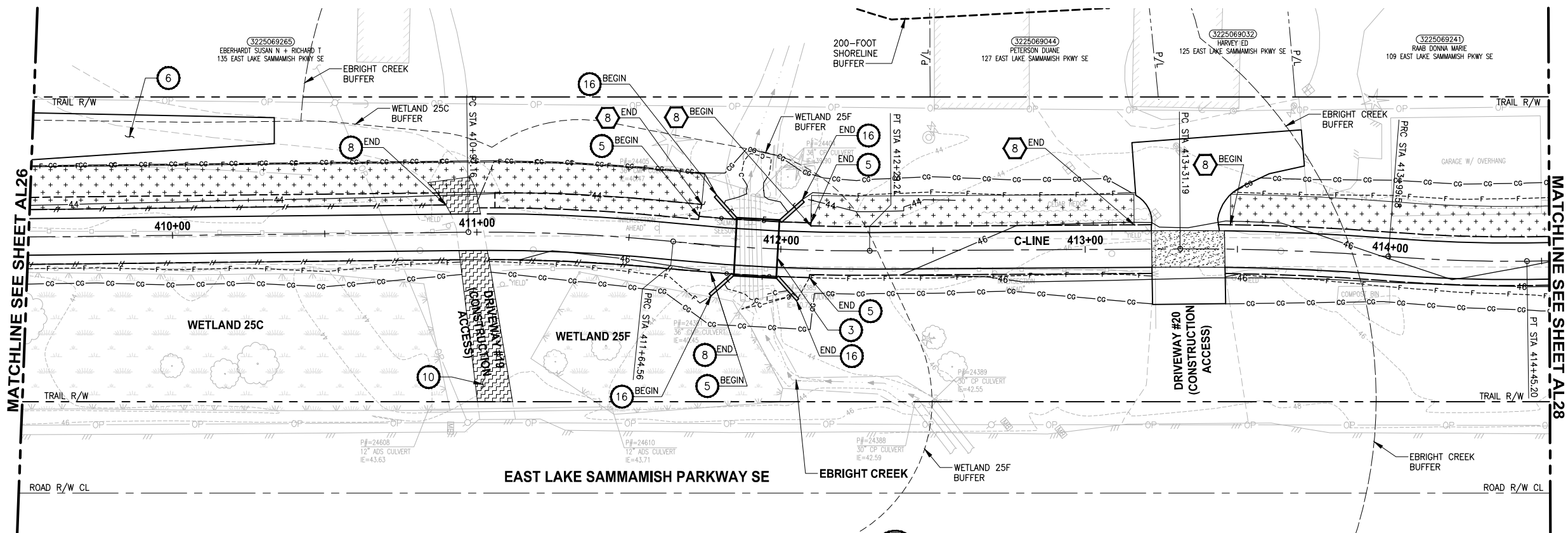
PROJECT NAME  
**EAST LAKE SAMMAMISH MASTER PLAN TRAIL SOUTH SAMMAMISH SEGMENT B**  
 SAMMAMISH, WA

**PLAN AND PROFILE**

SHEET NO.  
58 OF 135

**AL26**

PATH: U:\PSO\Projects\Clients\1521-KingCo\554-1521-075-ELST\995sca\CaDD\Phase 19\T03\_Civil\Draw\ PLOTTED BY: purgabut DATE: Wednesday, October 12, 2016 9:11:24 PM LAYOUT: AL27



**C-LINE PROFILE**  
 HORIZ: 1"=20'  
 VERT: 1"=5'

- CIVIL CONSTRUCTION NOTES:**
- 1 RESTORE AND INSTALL STAIR. TYPE TO BE DETERMINED.
  - 2 RECONSTRUCT PEDESTRIAN BRIDGE.
  - 3 INSTALL PRECAST REINF CONC SPLIT BOX CULVERT. SEE FP SHEETS FOR DETAILS.
  - 4 INSTALL STRUCTURAL EARTH WALL. SEE WALL DETAILS ON SHEET X. SEE WALL PROFILES ON WP SHEETS.
  - 5 INSTALL COATED CHAIN LINK FENCE TYPE 6. FOR GROUND POST INSTALLATION SEE APPENDIX B IN THE SPECIFICATIONS. SEE SHEET X FOR MOUNTING ON TOP OF WALL.
  - 6 NEW DRIVEWAY.
  - 7 INSTALL WOOD GUARDRAIL, SEE DETAILS ON SHEET XX.
  - 8 INSTALL SPLIT RAIL FENCE, SEE DETAILS ON SHEET XX.
  - 9 INSTALL GRAVITY BLOCK WALL. SEE WALL DETAILS ON SHEET WD1. SEE WALL PROFILES ON WP SHEETS.
  - 10 DRIVEWAY REMOVAL. SEE MP SHEETS FOR PLANTING PLAN.
  - 11 INSTALL PATTERNED CONCRETE DRIVEWAY. SEE DETAILS ON SHEET XX.
  - 12 INSTALL TYPE 1 REST STOP. SEE DETAILS ON SHEET XX.
  - 13 INSTALL TYPE 2 REST STOP. SEE DETAILS ON SHEET XX.
  - 14 INSTALL SOLDIER PILE WALL.
  - 15 INSTALL GRAVITY BLOCK WALL.
  - 16 INSTALL WING WALL, SEE FP SHEETS.
  - 17 INSTALL EXTRUDED CURB PER WSDOT STD PLAN F-10.42-00.
  - 18 REST STOP PULL-OUT.
  - 19 STAIRS WILL BE ELIMINATED DURING CONSTRUCTION.
  - 20 BRIDGES WILL BE REMOVED TO R/W LINE DURING CONSTRUCTION.
  - 21 INSTALL ROCK WALL.

- STORMWATER CONSTRUCTION NOTES:**
- 1 INFILTRATION TRENCH, SEE DETAIL 4 ON SHEET DD1.
  - 2 UNDERDRAIN TRENCH, SEE DETAIL 5 ON SHEET DD1.
  - 3 ROCK PAD, SEE DETAIL 2 ON SHEET DD1 AND WP SHEETS.
  - 4 CONNECTION TO DRAINAGE STRUCTURE AND CLEANING EXISTING DRAINAGE STRUCTURE.
  - 5 INSTALL UNDERDRAIN TRENCH CLEANOUT, SEE DETAIL 6 ON SHEET DD1.
  - 6 INSTALL RECTANGULAR SLIP RESISTANT SOLID METAL COVER PER WSDOT STD DETAIL B-30.20-02.
  - 7 CONCRETE HEADWALL, SEE DETAIL 1 ON SHEET DD1.
  - 8 BASIC DISPERSION, SEE SHEET CS3.
  - 9 QUARRY SPALL OUTFALL PROTECTION. SEE DETAIL 3 ON SHEET DD1.
  - 10 ADJUST CATCH BASIN.

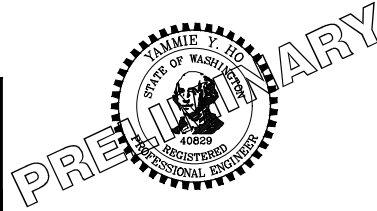
- LEGEND:**
- RETAINING WALL
  - SOLDIER PILE WALL
  - WOOD GUARDRAIL
  - DISPERSION AREA
  - DRIVEWAY REMOVAL

CITY OF SAMMAMISH APPROVAL	
City Engineer _____	Date _____
Community Development _____	Date _____

**60% REVIEW SUBMITTAL**  
 NOT FOR CONSTRUCTION

REVISIONS	DATE	BY	DESIGNED
			M. TSUN
			B. PURGANAN
			P. JOHANNESSEN
			Y. HO

**ONE INCH AT FULL SCALE, IF NOT, SCALE ACCORDINGLY**  
 FILE NAME: BL1521075P19T03AL-03  
 JOB No: 554-1521-075 P19 T03  
 DATE: SEPTEMBER 2016



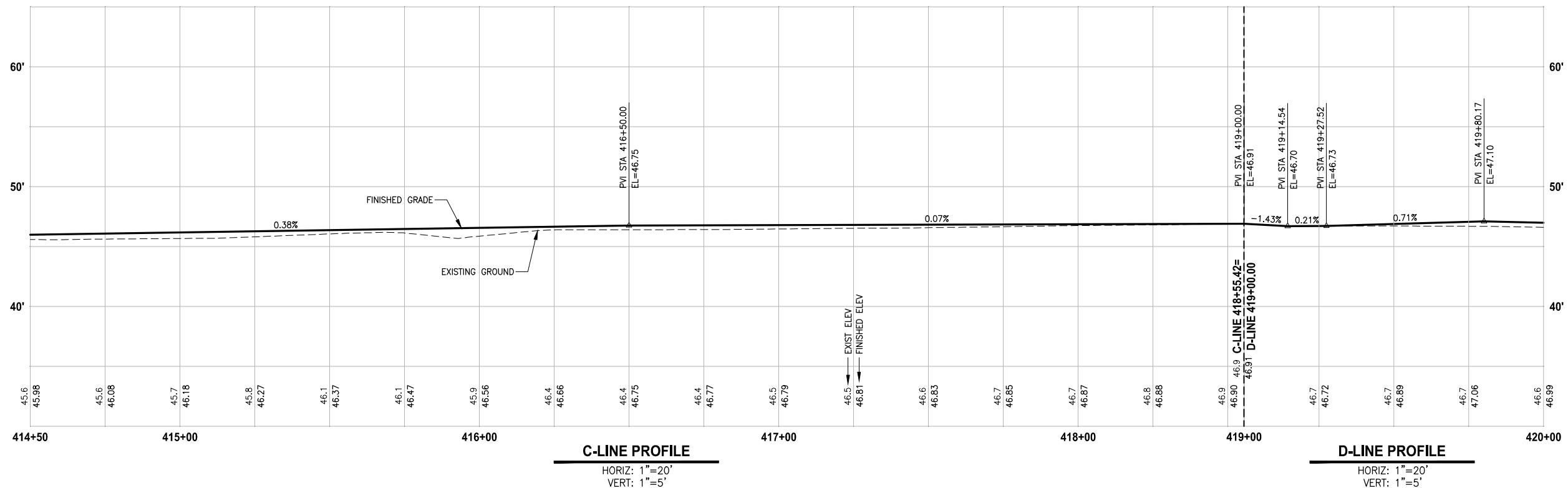
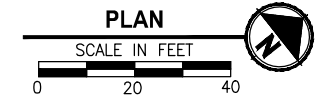
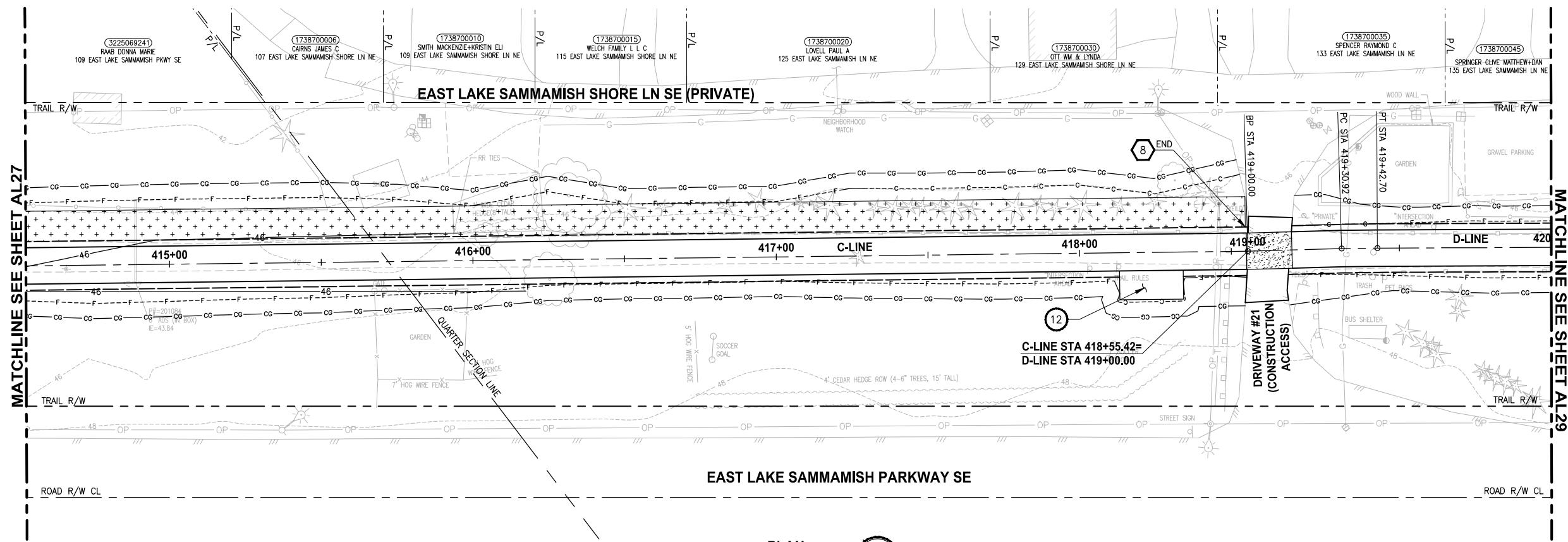
**Parametrix**  
 ENGINEERING · PLANNING · ENVIRONMENTAL SCIENCES  
 719 2ND AVENUE, SUITE 200 | SEATTLE, WA 98104  
 P 206.394.3700  
 WWW.PARAMETRIX.COM

PROJECT NAME  
**EAST LAKE SAMMAMISH MASTER PLAN TRAIL SOUTH SAMMAMISH SEGMENT B**  
 SAMMAMISH, WA

**PLAN AND PROFILE**

SHEET NO.  
 59 OF 135  
**AL27**

LAYOUT: AL28  
 PATH: U:\PSO\Projects\Clients\1521-1521-075-ELST\995sca\CaDD\Phase 19\103\_Civil\Draw\ PLOTTED BY: purgabut DATE: Wednesday, October 12, 2016 9:11:55 PM



- CIVIL CONSTRUCTION NOTES:**
- 1 RESTORE AND INSTALL STAIR. TYPE TO BE DETERMINED.
  - 2 RECONSTRUCT PEDESTRIAN BRIDGE.
  - 3 INSTALL PRECAST REINF CONC SPLIT BOX CULVERT. SEE FP SHEETS FOR DETAILS.
  - 4 INSTALL STRUCTURAL EARTH WALL. SEE WALL DETAILS ON SHEET X. SEE WALL PROFILES ON WP SHEETS.
  - 5 INSTALL COATED CHAIN LINK FENCE TYPE 6. FOR GROUND POST INSTALLATION SEE APPENDIX B IN THE SPECIFICATIONS. SEE SHEET X FOR MOUNTING ON TOP OF WALL.
  - 6 NEW DRIVEWAY.
  - 7 INSTALL WOOD GUARDRAIL, SEE DETAILS ON SHEET XX.
  - 8 INSTALL SPLIT RAIL FENCE, SEE DETAILS ON SHEET XX.
  - 9 INSTALL GRAVITY BLOCK WALL. SEE WALL DETAILS ON SHEET WD1. SEE WALL PROFILES ON WP SHEETS.
  - 10 DRIVEWAY REMOVAL. SEE MP SHEETS FOR PLANTING PLAN.
  - 11 INSTALL PATTERNED CONCRETE DRIVEWAY. SEE DETAILS ON SHEET XX.
  - 12 INSTALL TYPE 1 REST STOP. SEE DETAILS ON SHEET XX.
  - 13 INSTALL TYPE 2 REST STOP. SEE DETAILS ON SHEET XX.
  - 14 INSTALL SOLDIER PILE WALL.
  - 15 INSTALL GRAVITY BLOCK WALL.
  - 16 INSTALL WING WALL, SEE FP SHEETS.
  - 17 INSTALL EXTRUDED CURB PER WSDOT STD PLAN F-10.42-00.
  - 18 REST STOP PULL-OUT.
  - 19 STAIRS WILL BE ELIMINATED DURING CONSTRUCTION.
  - 20 BRIDGES WILL BE REMOVED TO R/W LINE DURING CONSTRUCTION.
  - 21 INSTALL ROCK WALL.

- STORMWATER CONSTRUCTION NOTES:**
- 1 INFILTRATION TRENCH, SEE DETAIL 4 ON SHEET DD1.
  - 2 UNDERDRAIN TRENCH, SEE DETAIL 5 ON SHEET DD1.
  - 3 ROCK PAD, SEE DETAIL 2 ON SHEET DD1 AND WP SHEETS.
  - 4 CONNECTION TO DRAINAGE STRUCTURE AND CLEANING EXISTING DRAINAGE STRUCTURE.
  - 5 INSTALL UNDERDRAIN TRENCH CLEANOUT, SEE DETAIL 6 ON SHEET DD1.
  - 6 INSTALL RECTANGULAR SLIP RESISTANT SOLID METAL COVER PER WSDOT STD DETAIL B-30.20-02.
  - 7 CONCRETE HEADWALL, SEE DETAIL 1 ON SHEET DD1.
  - 8 BASIC DISPERSION, SEE SHEET CS3.
  - 9 QUARRY SPALL OUTFALL PROTECTION. SEE DETAIL 3 ON SHEET DD1.
  - 10 ADJUST CATCH BASIN.

- LEGEND:**
- RETAINING WALL
  - SOLDIER PILE WALL
  - WOOD GUARDRAIL
  - DISPERSION AREA
  - DRIVEWAY REMOVAL

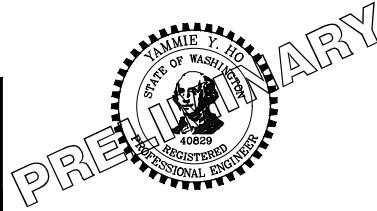
CITY OF SAMMAMISH APPROVAL	
City Engineer _____	Date _____
Community Development _____	Date _____

**60 % REVIEW SUBMITTAL  
NOT FOR CONSTRUCTION**

REVISIONS	DATE	BY	DESIGNED
			M. TSUN
			B. PURGANAN
			P. JOHANNESSEN
			Y. HO

ONE INCH AT FULL SCALE.  
IF NOT, SCALE ACCORDINGLY

FILE NAME: BL1521075P19T03AL-03  
 JOB No.: 554-1521-075 P19 T03  
 DATE: SEPTEMBER 2016



**Parametrix**  
 ENGINEERING · PLANNING · ENVIRONMENTAL SCIENCES

719 2ND AVENUE, SUITE 200 | SEATTLE, WA 98104  
 P 206.394.3700  
 WWW.PARAMETRIX.COM

PROJECT NAME  
**EAST LAKE SAMMAMISH  
 MASTER PLAN TRAIL  
 SOUTH SAMMAMISH SEGMENT B**  
 SAMMAMISH, WA

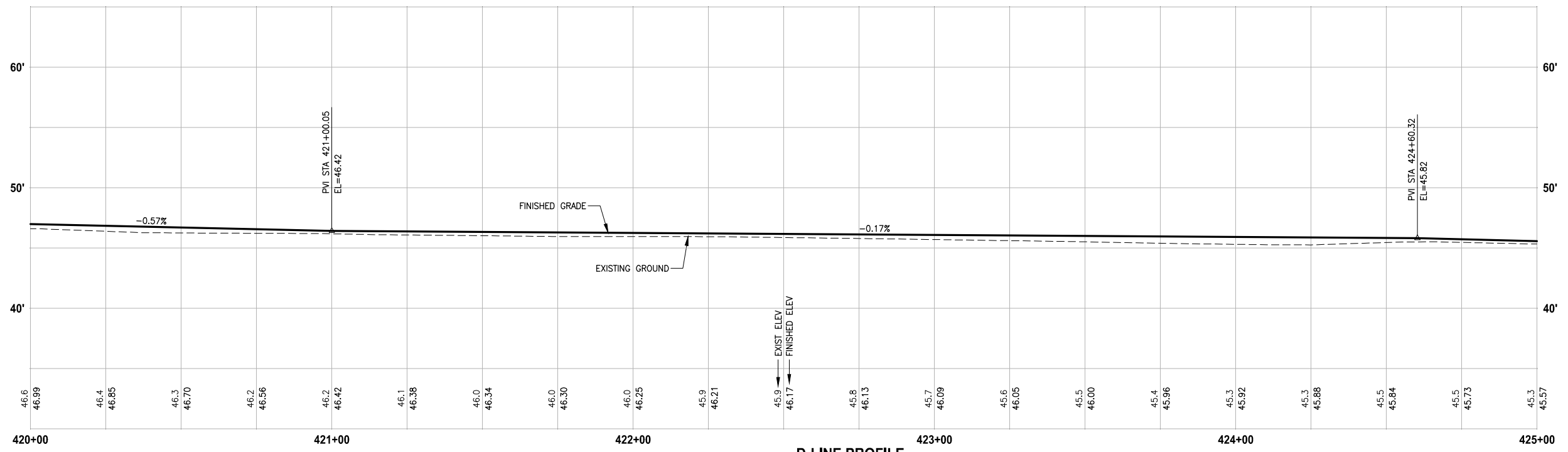
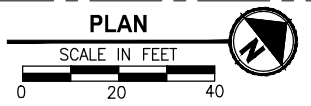
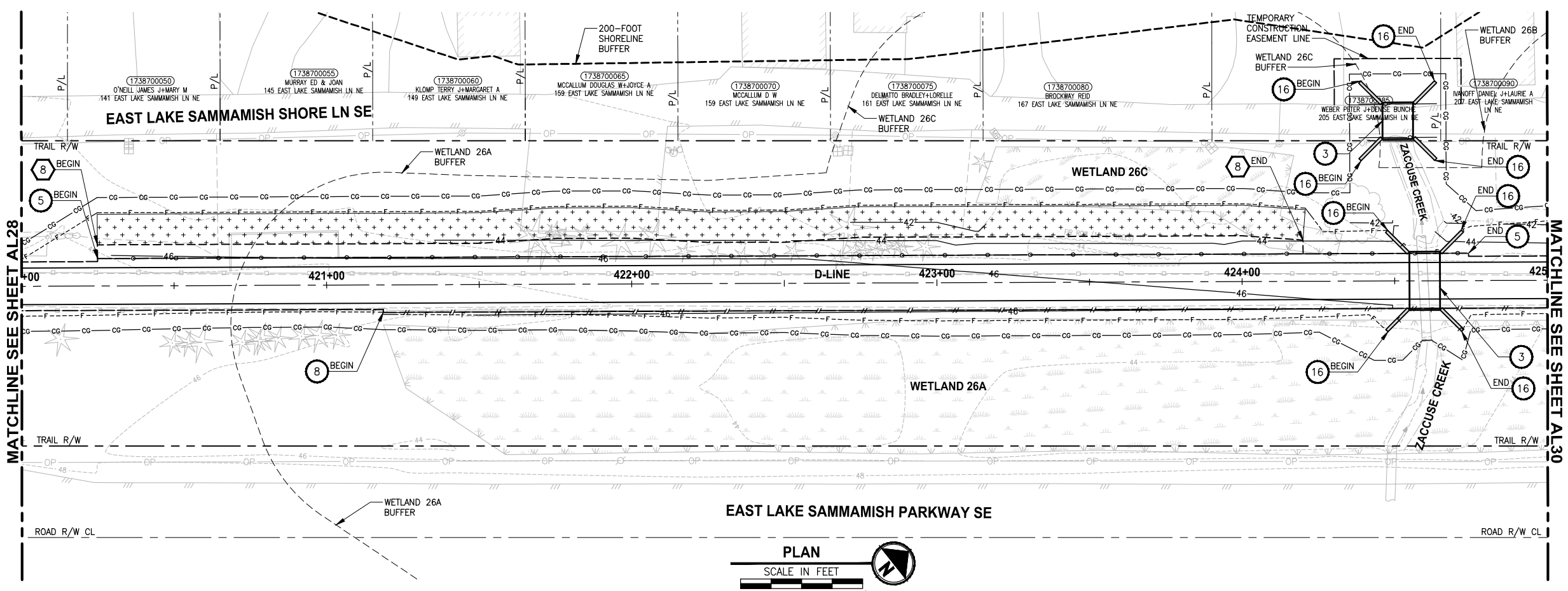
**PLAN AND PROFILE**

SHEET NO.  
60 OF 135

**AL28**



LAYOUT: AL29  
 PATH: U:\PSO\Projects\Clients\1521-KingCo\554-1521-075-ELST\995sca\CaDD\Phase 19\103\_Civil\Draw\ PLOTTED BY: purgaban DATE: Wednesday, October 12, 2016 9:15:55 PM



**D-LINE PROFILE**

HORIZ: 1"=20'  
VERT: 1"=5'

**CIVIL CONSTRUCTION NOTES:**

- 1 RESTORE AND INSTALL STAIR. TYPE TO BE DETERMINED.
- 2 RECONSTRUCT PEDESTRIAN BRIDGE.
- 3 INSTALL PRECAST REINF CONC SPLIT BOX CULVERT. SEE FP SHEETS FOR DETAILS.
- 4 INSTALL STRUCTURAL EARTH WALL. SEE WALL DETAILS ON SHEET X. SEE WALL PROFILES ON WP SHEETS.
- 5 INSTALL COATED CHAIN LINK FENCE TYPE 6. FOR GROUND POST INSTALLATION SEE APPENDIX B IN THE SPECIFICATIONS. SEE SHEET X FOR MOUNTING ON TOP OF WALL.
- 6 NEW DRIVEWAY.
- 7 INSTALL WOOD GUARDRAIL, SEE DETAILS ON SHEET XX.
- 8 INSTALL SPLIT RAIL FENCE, SEE DETAILS ON SHEET XX.
- 9 INSTALL GRAVITY BLOCK WALL. SEE WALL DETAILS ON SHEET WD1. SEE WALL PROFILES ON WP SHEETS.
- 10 DRIVEWAY REMOVAL. SEE MP SHEETS FOR PLANTING PLAN.
- 11 INSTALL PATTERNED CONCRETE DRIVEWAY. SEE DETAILS ON SHEET XX.
- 12 INSTALL TYPE 1 REST STOP. SEE DETAILS ON SHEET XX.
- 13 INSTALL TYPE 2 REST STOP. SEE DETAILS ON SHEET XX.
- 14 INSTALL SOLDIER PILE WALL.
- 15 INSTALL GRAVITY BLOCK WALL.
- 16 INSTALL WING WALL, SEE FP SHEETS.
- 17 INSTALL EXTRUDED CURB PER WSDOT STD PLAN F-10.42-00.
- 18 REST STOP PULL-OUT.
- 19 STAIRS WILL BE ELIMINATED DURING CONSTRUCTION.
- 20 BRIDGES WILL BE REMOVED TO R/W LINE DURING CONSTRUCTION.
- 21 INSTALL ROCK WALL.

**STORMWATER CONSTRUCTION NOTES:**

- 1 INFILTRATION TRENCH, SEE DETAIL 4 ON SHEET DD1.
- 2 UNDERDRAIN TRENCH, SEE DETAIL 5 ON SHEET DD1.
- 3 ROCK PAD, SEE DETAIL 2 ON SHEET DD1 AND WP SHEETS.
- 4 CONNECTION TO DRAINAGE STRUCTURE AND CLEANING EXISTING DRAINAGE STRUCTURE.
- 5 INSTALL UNDERDRAIN TRENCH CLEANOUT, SEE DETAIL 6 ON SHEET DD1.
- 6 INSTALL RECTANGULAR SLIP RESISTANT SOLID METAL COVER PER WSDOT STD DETAIL B-30.20-02.
- 7 CONCRETE HEADWALL, SEE DETAIL 1 ON SHEET DD1.
- 8 BASIC DISPERSION, SEE SHEET CS3.
- 9 QUARRY SPALL OUTFALL PROTECTION. SEE DETAIL 3 ON SHEET DD1.
- 10 ADJUST CATCH BASIN.

**LEGEND:**

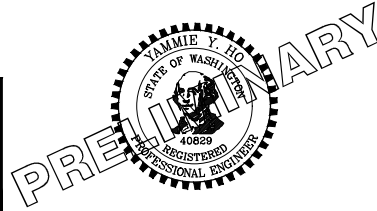
- RETAINING WALL
- SOLDIER PILE WALL
- WOOD GUARDRAIL
- DISPERSION AREA
- DRIVEWAY REMOVAL

CITY OF SAMMAMISH APPROVAL	
City Engineer _____	Date _____
Community Development _____	Date _____

**60 % REVIEW SUBMITTAL  
NOT FOR CONSTRUCTION**

REVISIONS	DATE	BY	DESIGNED
			M. TSUN
			B. PURGANAN
			P. JOHANNESSEN
			Y. HO

**ONE INCH AT FULL SCALE, IF NOT, SCALE ACCORDINGLY**  
 FILE NAME: BL1521075P19T03AL-04  
 JOB No.: 554-1521-075 P19 T03  
 DATE: SEPTEMBER 2016



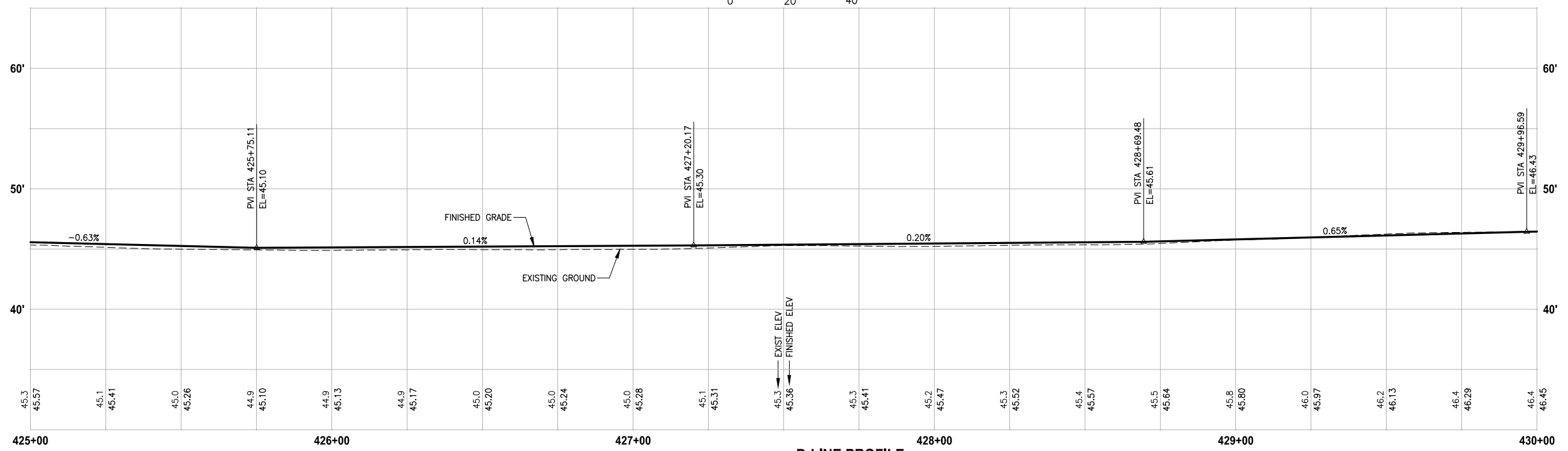
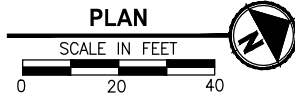
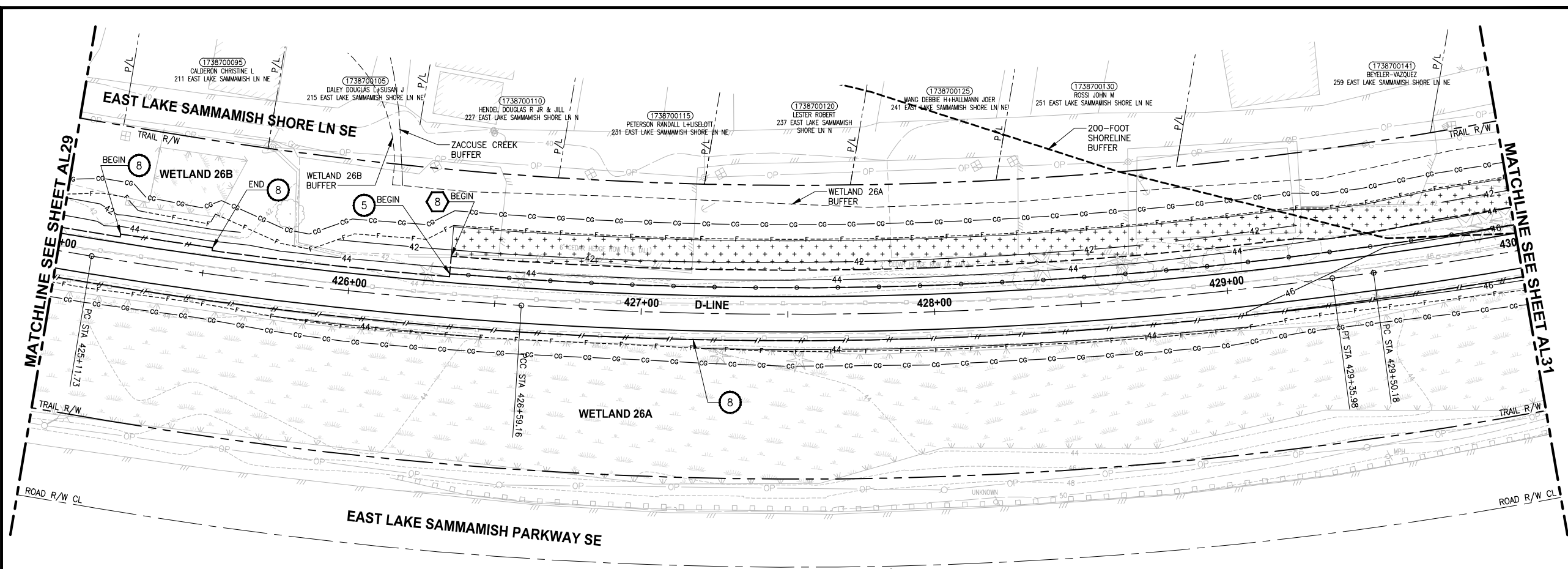
**Parametrix**  
 ENGINEERING · PLANNING · ENVIRONMENTAL SCIENCES  
 719 2ND AVENUE, SUITE 200 | SEATTLE, WA 98104  
 P 206.394.3700  
 WWW.PARAMETRIX.COM

PROJECT NAME  
**EAST LAKE SAMMAMISH  
 MASTER PLAN TRAIL  
 SOUTH SAMMAMISH SEGMENT B**  
 SAMMAMISH, WA

**PLAN AND PROFILE**

SHEET NO.  
 61 OF 135  
**AL29**

LAYOUT: AL30    PATH: U:\PSO\Projects\Clients\1521-KingCo\554-1521-075-ELST\995sca\CaDD\Phase 19\T03\_Civil\Draw\    PLOTTED BY: purgabut    DATE: Wednesday, October 12, 2016 9:16:21 PM



**D-LINE PROFILE**  
 HORIZ: 1"=20'  
 VERT: 1"=5'

- CIVIL CONSTRUCTION NOTES:**
- 1 RESTORE AND INSTALL STAIR. TYPE TO BE DETERMINED.
  - 2 RECONSTRUCT PEDESTRIAN BRIDGE.
  - 3 INSTALL PRECAST REINF CONC SPLIT BOX CULVERT. SEE FP SHEETS FOR DETAILS.
  - 4 INSTALL STRUCTURAL EARTH WALL. SEE WALL DETAILS ON SHEET X. SEE WALL PROFILES ON WP SHEETS.
  - 5 INSTALL COATED CHAIN LINK FENCE TYPE 6. FOR GROUND POST INSTALLATION SEE APPENDIX B IN THE SPECIFICATIONS. SEE SHEET X FOR MOUNTING ON TOP OF WALL.
  - 6 NEW DRIVEWAY.
  - 7 INSTALL WOOD GUARDRAIL, SEE DETAILS ON SHEET XX.
  - 8 INSTALL SPLIT RAIL FENCE, SEE DETAILS ON SHEET XX.
  - 9 INSTALL GRAVITY BLOCK WALL. SEE WALL DETAILS ON SHEET WD1. SEE WALL PROFILES ON WP SHEETS.
  - 10 DRIVEWAY REMOVAL. SEE MP SHEETS FOR PLANTING PLAN.
  - 11 INSTALL PATTERNED CONCRETE DRIVEWAY. SEE DETAILS ON SHEET XX.
  - 12 INSTALL TYPE 1 REST STOP. SEE DETAILS ON SHEET XX.
  - 13 INSTALL TYPE 2 REST STOP. SEE DETAILS ON SHEET XX.
  - 14 INSTALL SOLDIER PILE WALL.
  - 15 INSTALL GRAVITY BLOCK WALL.
  - 16 INSTALL WING WALL. SEE FP SHEETS.
  - 17 INSTALL EXTRUDED CURB PER WSDOT STD PLAN F-10.42-00.
  - 18 REST STOP PULL-OUT.
  - 19 STAIRS WILL BE ELIMINATED DURING CONSTRUCTION.
  - 20 BRIDGES WILL BE REMOVED TO R/W LINE DURING CONSTRUCTION.
  - 21 INSTALL ROCK WALL.

- STORMWATER CONSTRUCTION NOTES:**
- 1 INFILTRATION TRENCH, SEE DETAIL 4 ON SHEET DD1.
  - 2 UNDERDRAIN TRENCH, SEE DETAIL 5 ON SHEET DD1.
  - 3 ROCK PAD, SEE DETAIL 2 ON SHEET DD1 AND WP SHEETS.
  - 4 CONNECTION TO DRAINAGE STRUCTURE AND CLEANING EXISTING DRAINAGE STRUCTURE.
  - 5 INSTALL UNDERDRAIN TRENCH CLEANOUT, SEE DETAIL 6 ON SHEET DD1.
  - 6 INSTALL RECTANGULAR SLIP RESISTANT SOLID METAL COVER PER WSDOT STD DETAIL B-30.20-02.
  - 7 CONCRETE HEADWALL, SEE DETAIL 1 ON SHEET DD1.
  - 8 BASIC DISPERSION, SEE SHEET CS3.
  - 9 QUARRY SPALL OUTFALL PROTECTION. SEE DETAIL 3 ON SHEET DD1.
  - 10 ADJUST CATCH BASIN.

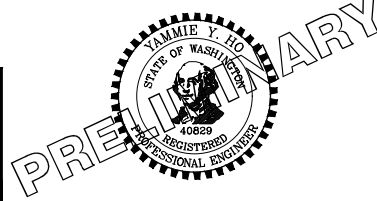
- LEGEND:**
- RETAINING WALL
  - SOLDIER PILE WALL
  - WOOD GUARDRAIL
  - DISPERSION AREA
  - DRIVEWAY REMOVAL

CITY OF SAMMAMISH APPROVAL	
City Engineer _____	Date _____
Community Development _____	Date _____

**60 % REVIEW SUBMITTAL**  
 NOT FOR CONSTRUCTION

REVISIONS	DATE	BY	DESIGNED
			M. TSUN
			B. PURGANAN
			P. JOHANNESSEN
			Y. HO

ONE INCH AT FULL SCALE.  
 IF NOT, SCALE ACCORDINGLY.  
 FILE NAME: BL1521075P19T03AL-04  
 JOB No: 554-1521-075 P19 T03  
 DATE: SEPTEMBER 2016



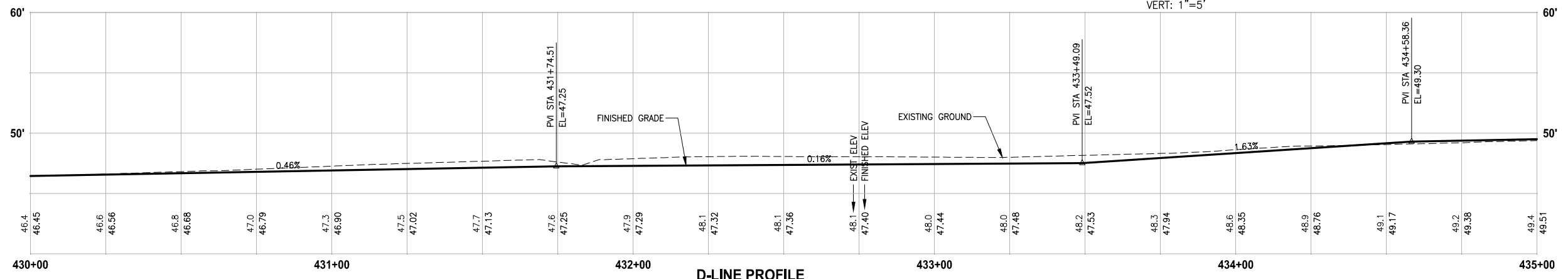
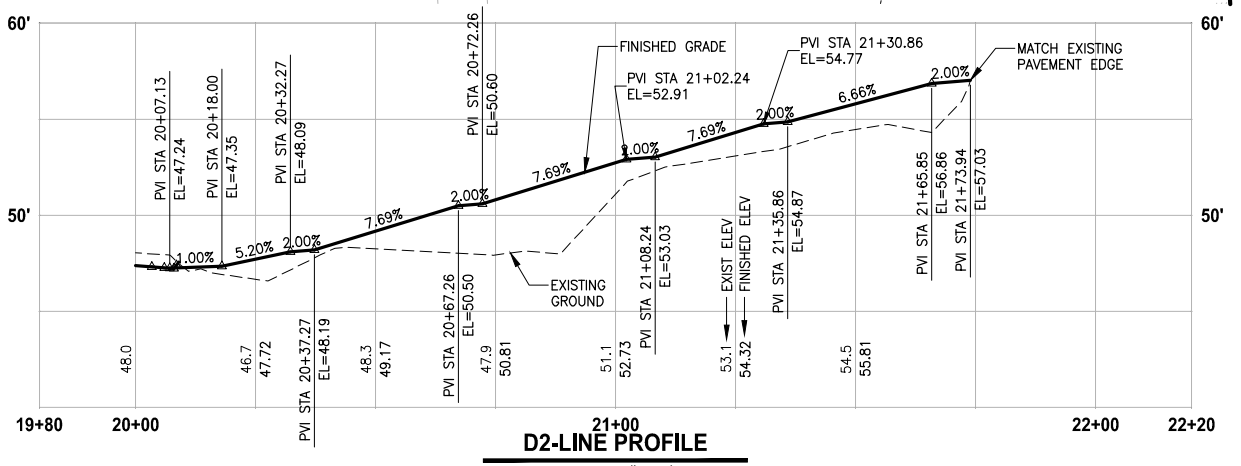
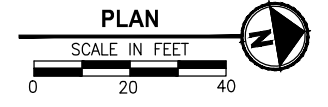
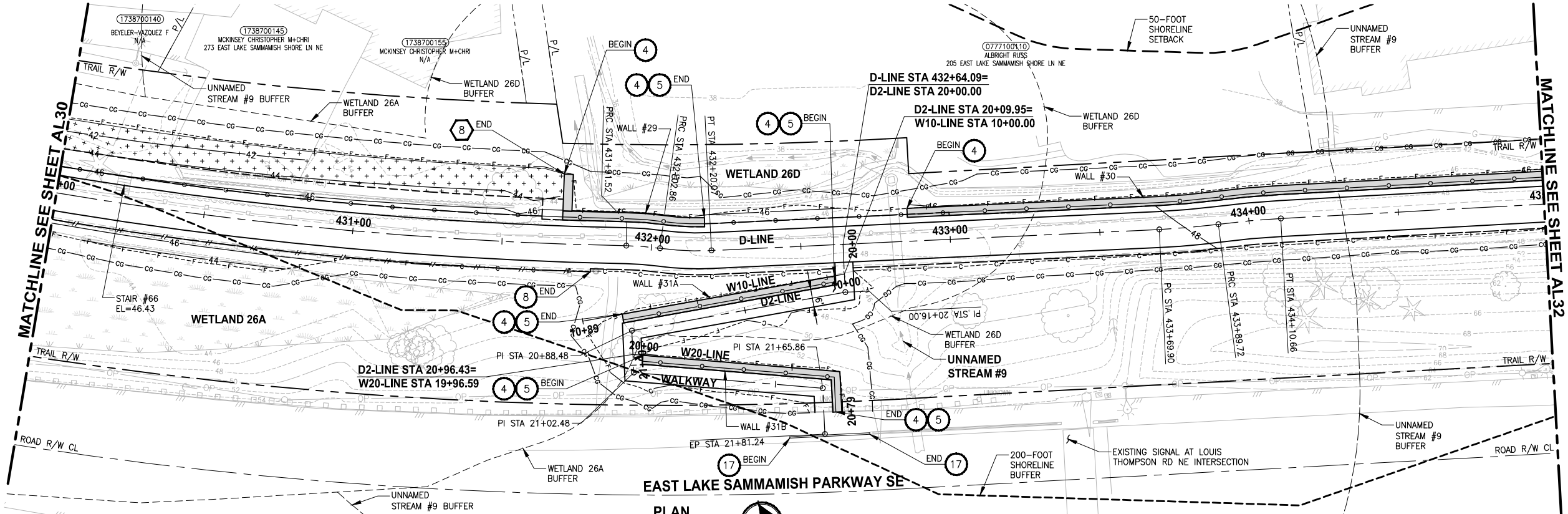
**Parametrix**  
 ENGINEERING · PLANNING · ENVIRONMENTAL SCIENCES  
 719 2ND AVENUE, SUITE 200 | SEATTLE, WA 98104  
 P 206.394.3700  
 WWW.PARAMETRIX.COM

PROJECT NAME  
**EAST LAKE SAMMAMISH  
 MASTER PLAN TRAIL  
 SOUTH SAMMAMISH SEGMENT B**  
 SAMMAMISH, WA

**PLAN AND PROFILE**  
 SHEET NO.  
 62 OF 135  
**AL30**

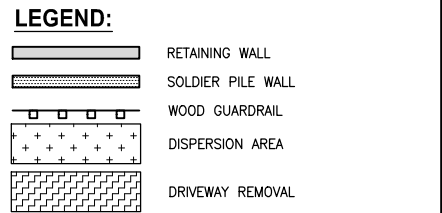


LAYOUT: AL31  
 PATH: U:\PSO\Projects\Clients\1521-KingCo\1554-1521-075-ELST\995\cadd\Phase 19\T03\_Civil\DWG\ PLOTTED BY: purgabul DATE: Wednesday, October 12, 2016 9:16:54 PM



- CIVIL CONSTRUCTION NOTES:**
- 1 RESTORE AND INSTALL STAIR. TYPE TO BE DETERMINED.
  - 2 RECONSTRUCT PEDESTRIAN BRIDGE.
  - 3 INSTALL PRECAST REINF CONC SPLIT BOX CULVERT. SEE FP SHEETS FOR DETAILS.
  - 4 INSTALL STRUCTURAL EARTH WALL. SEE WALL DETAILS ON SHEET X. SEE WALL PROFILES ON WP SHEETS.
  - 5 INSTALL COATED CHAIN LINK FENCE TYPE 6. FOR GROUND POST INSTALLATION SEE APPENDIX B IN THE SPECIFICATIONS. SEE SHEET X FOR MOUNTING ON TOP OF WALL.
  - 6 NEW DRIVEWAY.
  - 7 INSTALL WOOD GUARDRAIL, SEE DETAILS ON SHEET XX.
  - 8 INSTALL SPLIT RAIL FENCE, SEE DETAILS ON SHEET XX.
  - 9 INSTALL GRAVITY BLOCK WALL. SEE WALL DETAILS ON SHEET WD1. SEE WALL PROFILES ON WP SHEETS.
  - 10 DRIVEWAY REMOVAL. SEE MP SHEETS FOR PLANTING PLAN.
  - 11 INSTALL PATTERNED CONCRETE DRIVEWAY. SEE DETAILS ON SHEET XX.
  - 12 INSTALL TYPE 1 REST STOP. SEE DETAILS ON SHEET XX.
  - 13 INSTALL TYPE 2 REST STOP. SEE DETAILS ON SHEET XX.
  - 14 INSTALL SOLDIER PILE WALL.
  - 15 INSTALL GRAVITY BLOCK WALL.
  - 16 INSTALL WING WALL, SEE FP SHEETS.
  - 17 INSTALL EXTRUDED CURB PER WSDOT STD PLAN F-10.42-00.
  - 18 REST STOP PULL-OUT.
  - 19 STAIRS WILL BE ELIMINATED DURING CONSTRUCTION.
  - 20 BRIDGES WILL BE REMOVED TO R/W LINE DURING CONSTRUCTION.
  - 21 INSTALL ROCK WALL.

- STORMWATER CONSTRUCTION NOTES:**
- 1 INFILTRATION TRENCH, SEE DETAIL 4 ON SHEET DD1.
  - 2 UNDERDRAIN TRENCH, SEE DETAIL 5 ON SHEET DD1.
  - 3 ROCK PAD, SEE DETAIL 2 ON SHEET DD1 AND WP SHEETS.
  - 4 CONNECTION TO DRAINAGE STRUCTURE AND CLEANING EXISTING DRAINAGE STRUCTURE.
  - 5 INSTALL UNDERDRAIN TRENCH CLEANOUT, SEE DETAIL 6 ON SHEET DD1.
  - 6 INSTALL RECTANGULAR SLIP RESISTANT SOLID METAL COVER PER WSDOT STD DETAIL B-30.20-02.
  - 7 CONCRETE HEADWALL, SEE DETAIL 1 ON SHEET DD1.
  - 8 BASIC DISPERSION, SEE SHEET CS3.
  - 9 QUARRY SPALL OUTFALL PROTECTION. SEE DETAIL 3 ON SHEET DD1.
  - 10 ADJUST CATCH BASIN.



**CITY OF SAMMAMISH APPROVAL**

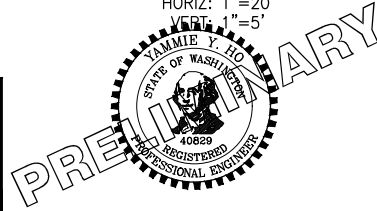
City Engineer _____	Date _____
Community Development _____	Date _____

**60 % REVIEW SUBMITTAL  
NOT FOR CONSTRUCTION**

REVISIONS	DATE	BY	DESIGNED
			M. TSUN
			B. PURGANAN
			P. JOHANNESSEN
			Y. HO

**ONE INCH AT FULL SCALE, IF NOT, SCALE ACCORDINGLY**

FILE NAME: BL1521075P19T03AL-04  
 JOB No.: 554-1521-075 P19 T03  
 DATE: SEPTEMBER 2016



**Parametrix**  
 ENGINEERING · PLANNING · ENVIRONMENTAL SCIENCES

719 2ND AVENUE, SUITE 200 | SEATTLE, WA 98104  
 P 206.394.3700  
 WWW.PARAMETRIX.COM

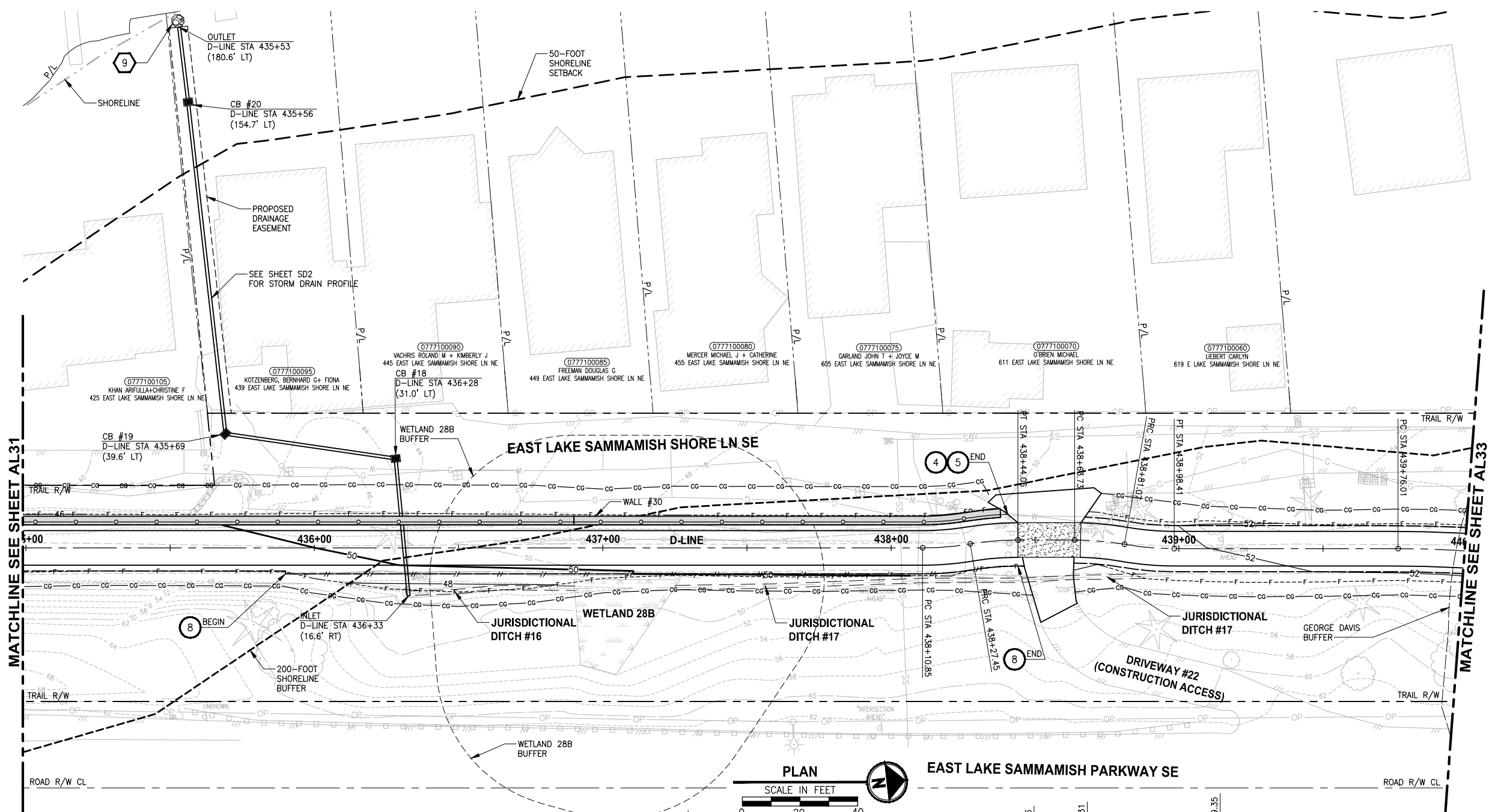
PROJECT NAME  
**EAST LAKE SAMMAMISH  
 MASTER PLAN TRAIL  
 SOUTH SAMMAMISH SEGMENT B**  
 SAMMAMISH, WA

**PLAN AND PROFILE**

SHEET NO.  
 63 OF 135  
**AL31**

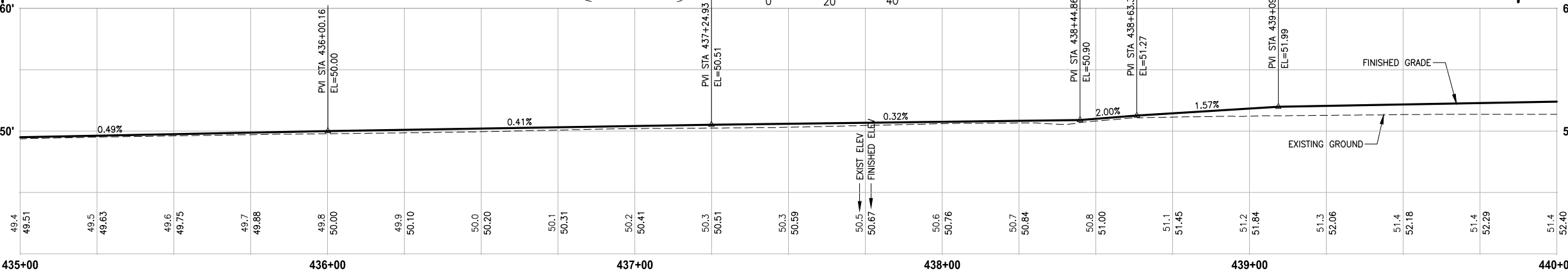


LAYOUT: AL32  
 PATH: U:\PSO\Projects\Clients\1521-075-ELST\995sca\CaDD\Phase 19\103\_Civil\Draw\ PLOTTED BY: purgaban DATE: Wednesday, October 12, 2016 9:17:22 PM



MATCHLINE SEE SHEET AL31

MATCHLINE SEE SHEET AL33



- CIVIL CONSTRUCTION NOTES:**
- RESTORE AND INSTALL STAIR. TYPE TO BE DETERMINED.
  - RECONSTRUCT PEDESTRIAN BRIDGE.
  - INSTALL PRECAST REINF CONC SPLIT BOX CULVERT. SEE FP SHEETS FOR DETAILS.
  - INSTALL STRUCTURAL EARTH WALL. SEE WALL DETAILS ON SHEET X. SEE WALL PROFILES ON WP SHEETS.
  - INSTALL COATED CHAIN LINK FENCE TYPE 6. FOR GROUND POST INSTALLATION SEE APPENDIX B IN THE SPECIFICATIONS. SEE SHEET X FOR MOUNTING ON TOP OF WALL.
  - NEW DRIVEWAY.
  - INSTALL WOOD GUARDRAIL, SEE DETAILS ON SHEET XX.
  - INSTALL SPLIT RAIL FENCE, SEE DETAILS ON SHEET XX.
  - INSTALL GRAVITY BLOCK WALL. SEE WALL DETAILS ON SHEET WD1. SEE WALL PROFILES ON WP SHEETS.
  - DRIVEWAY REMOVAL. SEE MP SHEETS FOR PLANTING PLAN.
  - INSTALL PATTERNED CONCRETE DRIVEWAY. SEE DETAILS ON SHEET XX.
  - INSTALL TYPE 1 REST STOP. SEE DETAILS ON SHEET XX.
  - INSTALL TYPE 2 REST STOP. SEE DETAILS ON SHEET XX.
  - INSTALL SOLDIER PILE WALL.
  - INSTALL GRAVITY BLOCK WALL.
  - INSTALL WING WALL, SEE FP SHEETS.
  - INSTALL EXTRUDED CURB PER WSDOT STD PLAN F-10.42-00.
  - REST STOP PULL-OUT.
  - STAIRS WILL BE ELIMINATED DURING CONSTRUCTION.
  - BRIDGES WILL BE REMOVED TO R/W LINE DURING CONSTRUCTION.
  - INSTALL ROCK WALL.

- STORMWATER CONSTRUCTION NOTES:**
- INFILTRATION TRENCH, SEE DETAIL 4 ON SHEET DD1.
  - UNDERDRAIN TRENCH, SEE DETAIL 5 ON SHEET DD1.
  - ROCK PAD, SEE DETAIL 2 ON SHEET DD1 AND WP SHEETS.
  - CONNECTION TO DRAINAGE STRUCTURE AND CLEANING EXISTING DRAINAGE STRUCTURE.
  - INSTALL UNDERDRAIN TRENCH CLEANOUT, SEE DETAIL 6 ON SHEET DD1.
  - INSTALL RECTANGULAR SLIP RESISTANT SOLID METAL COVER PER WSDOT STD DETAIL B-30.20-02.
  - CONCRETE HEADWALL, SEE DETAIL 1 ON SHEET DD1.
  - BASIC DISPERSION, SEE SHEET CS3.
  - QUARRY SPALL OUTFALL PROTECTION. SEE DETAIL 3 ON SHEET DD1.
  - ADJUST CATCH BASIN.

**LEGEND:**

- RETAINING WALL
- SOLDIER PILE WALL
- WOOD GUARDRAIL
- DISPERSION AREA
- DRIVEWAY REMOVAL

**CITY OF SAMMAMISH APPROVAL**

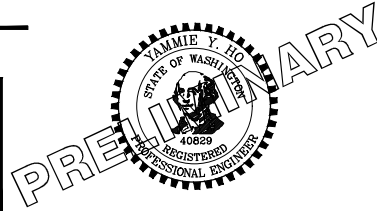
City Engineer _____	Date _____
Community Development _____	Date _____

**60% REVIEW SUBMITTAL**  
NOT FOR CONSTRUCTION

REVISIONS	DATE	BY	DESIGNED
			M. TSUN
			B. PURGANAN
			P. JOHANNESSEN
			Y. HO

**ONE INCH AT FULL SCALE, IF NOT, SCALE ACCORDINGLY**

FILE NAME: BL1521075P19T03AL-04  
 JOB No: 554-1521-075 P19 T03  
 DATE: SEPTEMBER 2016



**Parametrix**  
ENGINEERING · PLANNING · ENVIRONMENTAL SCIENCES

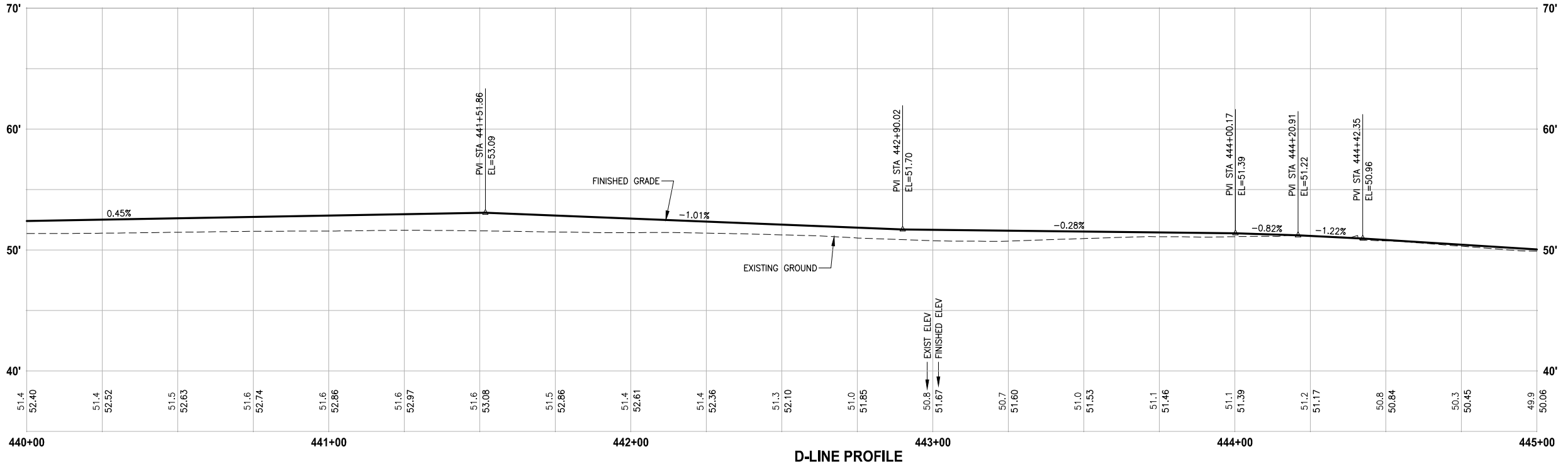
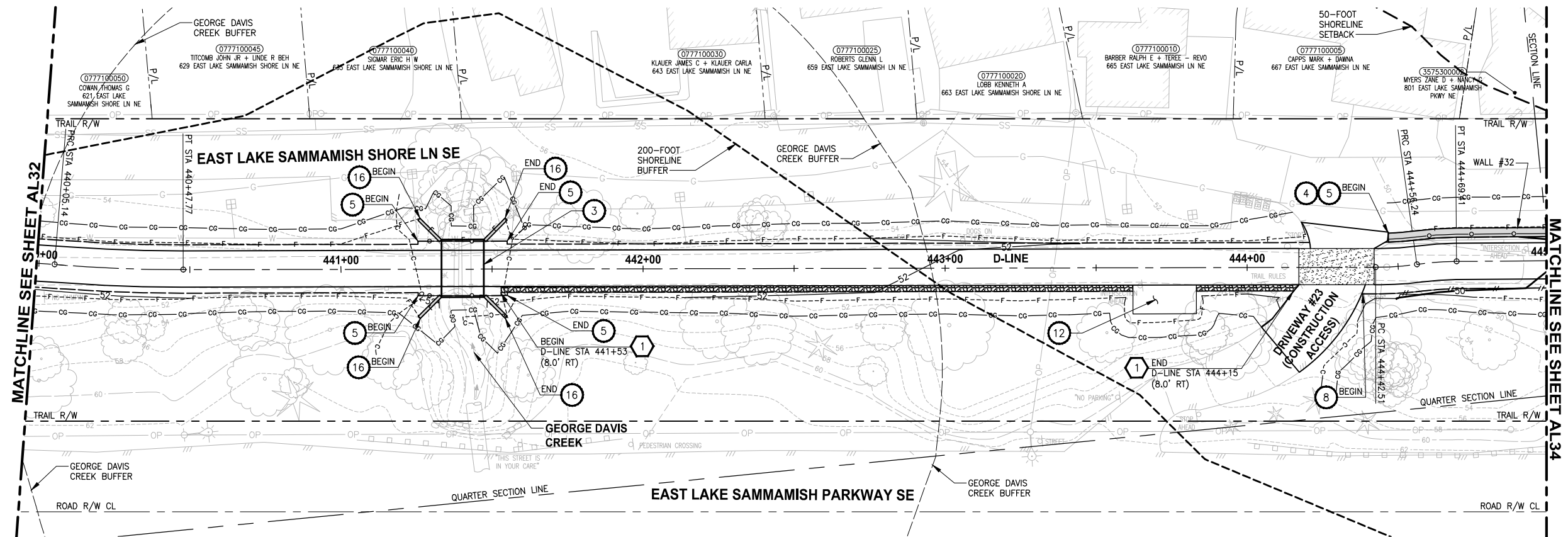
719 2ND AVENUE, SUITE 200 | SEATTLE, WA 98104  
 P 206.394.3700  
 WWW.PARAMETRIX.COM

PROJECT NAME  
**EAST LAKE SAMMAMISH MASTER PLAN TRAIL SOUTH SAMMAMISH SEGMENT B**  
 SAMMAMISH, WA

**PLAN AND PROFILE**

SHEET NO.  
64 OF 135  
**AL32**

PATH: U:\PSO\Projects\Clients\1521-075-ELST\995sca\CaDD\Phase 19\T03\_Civil\Draw\ PLOTTED BY: purgabut DATE: Wednesday, October 12, 2016 9:17:51 PM LAYOUT: AL33



**D-LINE PROFILE**

HORIZ: 1"=20'  
VERT: 1"=5'

**CIVIL CONSTRUCTION NOTES:**

- 1 RESTORE AND INSTALL STAIR. TYPE TO BE DETERMINED.
- 2 RECONSTRUCT PEDESTRIAN BRIDGE.
- 3 INSTALL PRECAST REINF CONC SPLIT BOX CULVERT. SEE FP SHEETS FOR DETAILS.
- 4 INSTALL STRUCTURAL EARTH WALL. SEE WALL DETAILS ON SHEET X. SEE WALL PROFILES ON WP SHEETS.
- 5 INSTALL COATED CHAIN LINK FENCE TYPE 6. FOR GROUND POST INSTALLATION SEE APPENDIX B IN THE SPECIFICATIONS. SEE SHEET X FOR MOUNTING ON TOP OF WALL.
- 6 NEW DRIVEWAY.
- 7 INSTALL WOOD GUARDRAIL, SEE DETAILS ON SHEET XX.
- 8 INSTALL SPLIT RAIL FENCE, SEE DETAILS ON SHEET XX.
- 9 INSTALL GRAVITY BLOCK WALL. SEE WALL DETAILS ON SHEET WD1. SEE WALL PROFILES ON WP SHEETS.
- 10 DRIVEWAY REMOVAL. SEE MP SHEETS FOR PLANTING PLAN.
- 11 INSTALL PATTERNED CONCRETE DRIVEWAY. SEE DETAILS ON SHEET XX.
- 12 INSTALL TYPE 1 REST STOP. SEE DETAILS ON SHEET XX.
- 13 INSTALL TYPE 2 REST STOP. SEE DETAILS ON SHEET XX.
- 14 INSTALL SOLDIER PILE WALL.
- 15 INSTALL GRAVITY BLOCK WALL.
- 16 INSTALL WING WALL, SEE FP SHEETS.
- 17 INSTALL EXTRUDED CURB PER WSDOT STD PLAN F-10.42-00.
- 18 REST STOP PULL-OUT.
- 19 STAIRS WILL BE ELIMINATED DURING CONSTRUCTION.
- 20 BRIDGES WILL BE REMOVED TO R/W LINE DURING CONSTRUCTION.
- 21 INSTALL ROCK WALL.

**STORMWATER CONSTRUCTION NOTES:**

- 1 INFILTRATION TRENCH, SEE DETAIL 4 ON SHEET DD1.
- 2 UNDERDRAIN TRENCH, SEE DETAIL 5 ON SHEET DD1.
- 3 ROCK PAD, SEE DETAIL 2 ON SHEET DD1 AND WP SHEETS.
- 4 CONNECTION TO DRAINAGE STRUCTURE AND CLEANING EXISTING DRAINAGE STRUCTURE.
- 5 INSTALL UNDERDRAIN TRENCH CLEANOUT, SEE DETAIL 6 ON SHEET DD1.
- 6 INSTALL RECTANGULAR SLIP RESISTANT SOLID METAL COVER PER WSDOT STD DETAIL B-30.20-02.
- 7 CONCRETE HEADWALL, SEE DETAIL 1 ON SHEET DD1.
- 8 BASIC DISPERSION, SEE SHEET CS3.
- 9 QUARRY SPALL OUTFALL PROTECTION. SEE DETAIL 3 ON SHEET DD1.
- 10 ADJUST CATCH BASIN.

**LEGEND:**

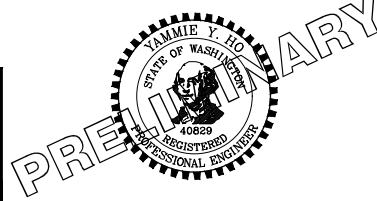
- RETAINING WALL
- SOLDIER PILE WALL
- WOOD GUARDRAIL
- DISPERSION AREA
- DRIVEWAY REMOVAL

CITY OF SAMMAMISH APPROVAL	
City Engineer _____	Date _____
Community Development _____	Date _____

**60% REVIEW SUBMITTAL**  
NOT FOR CONSTRUCTION

REVISIONS	DATE	BY	DESIGNED
			M. TSUN
			B. PURGANAN
			P. JOHANNESSEN
			Y. HO

ONE INCH AT FULL SCALE, IF NOT, SCALE ACCORDINGLY  
FILE NAME: BL1521075P19T03AL-04  
JOB No: 554-1521-075 P19 T03  
DATE: SEPTEMBER 2016



**Parametrix**  
ENGINEERING · PLANNING · ENVIRONMENTAL SCIENCES  
719 2ND AVENUE, SUITE 200 | SEATTLE, WA 98104  
P 206.394.3700  
WWW.PARAMETRIX.COM

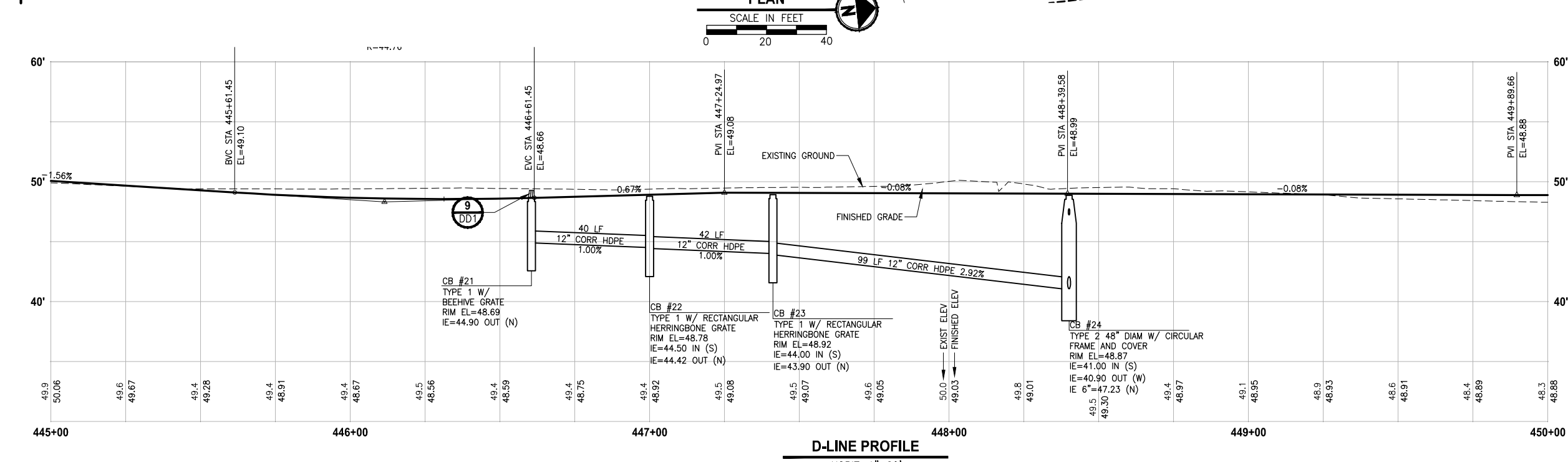
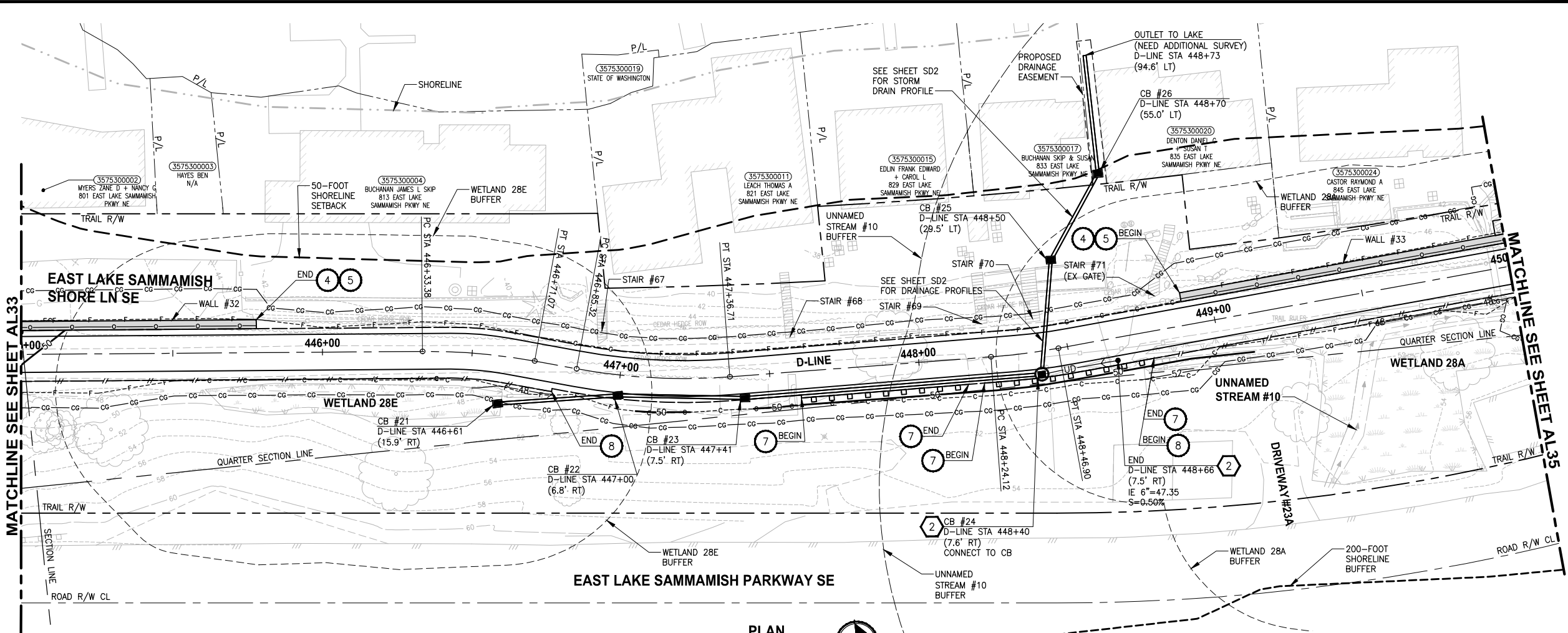
PROJECT NAME  
**EAST LAKE SAMMAMISH MASTER PLAN TRAIL SOUTH SAMMAMISH SEGMENT B**  
SAMMAMISH, WA

**PLAN AND PROFILE**

SHEET NO.  
65 OF 135  
**AL33**



LAYOUT: AL34  
 PATH: U:\PSO\Projects\Clients\1521-1521-075-ELST\99503\CaDD\Phase 19\T03\_Civil\Draw\ PLOTTED BY: purgabut DATE: Wednesday, October 12, 2016 9:18:20 PM



- CIVIL CONSTRUCTION NOTES:**
- RESTORE AND INSTALL STAIR. TYPE TO BE DETERMINED.
  - RECONSTRUCT PEDESTRIAN BRIDGE.
  - INSTALL PRECAST REINF CONC SPLIT BOX CULVERT. SEE FP SHEETS FOR DETAILS.
  - INSTALL STRUCTURAL EARTH WALL. SEE WALL DETAILS ON SHEET X. SEE WALL PROFILES ON WP SHEETS.
  - INSTALL COATED CHAIN LINK FENCE TYPE 6. FOR GROUND POST INSTALLATION SEE APPENDIX B IN THE SPECIFICATIONS. SEE SHEET X FOR MOUNTING ON TOP OF WALL.
  - NEW DRIVEWAY.
  - INSTALL WOOD GUARDRAIL, SEE DETAILS ON SHEET XX.
  - INSTALL SPLIT RAIL FENCE, SEE DETAILS ON SHEET XX.
  - INSTALL GRAVITY BLOCK WALL. SEE WALL DETAILS ON SHEET WD1. SEE WALL PROFILES ON WP SHEETS.
  - DRIVEWAY REMOVAL. SEE MP SHEETS FOR PLANTING PLAN.
  - INSTALL PATTERNED CONCRETE DRIVEWAY. SEE DETAILS ON SHEET XX.
  - INSTALL TYPE 1 REST STOP. SEE DETAILS ON SHEET XX.
  - INSTALL TYPE 2 REST STOP. SEE DETAILS ON SHEET XX.
  - INSTALL SOLDIER PILE WALL.
  - INSTALL GRAVITY BLOCK WALL.
  - INSTALL EXTRUDED CURB PER WSDOT STD PLAN F-10.42-00.
  - REST STOP PULL-OUT.
  - STAIRS WILL BE ELIMINATED DURING CONSTRUCTION.
  - BRIDGES WILL BE REMOVED TO R/W LINE DURING CONSTRUCTION.
  - INSTALL ROCK WALL.

- STORMWATER CONSTRUCTION NOTES:**
- INFILTRATION TRENCH, SEE DETAIL 4 ON SHEET DD1.
  - UNDERDRAIN TRENCH, SEE DETAIL 5 ON SHEET DD1.
  - ROCK PAD, SEE DETAIL 2 ON SHEET DD1 AND WP SHEETS.
  - CONNECTION TO DRAINAGE STRUCTURE AND CLEANING EXISTING DRAINAGE STRUCTURE.
  - INSTALL UNDERDRAIN TRENCH CLEANOUT, SEE DETAIL 6 ON SHEET DD1.
  - INSTALL RECTANGULAR SLIP RESISTANT SOLID METAL COVER PER WSDOT STD DETAIL B-30.20-02.
  - CONCRETE HEADWALL, SEE DETAIL 1 ON SHEET DD1.
  - BASIC DISPERSION, SEE SHEET CS3.
  - QUARRY SPALL OUTFALL PROTECTION. SEE DETAIL 3 ON SHEET DD1.
  - ADJUST CATCH BASIN.

- LEGEND:**
- RETAINING WALL
  - SOLDIER PILE WALL
  - WOOD GUARDRAIL
  - DISPERSION AREA
  - DRIVEWAY REMOVAL

**CITY OF SAMMAMISH APPROVAL**

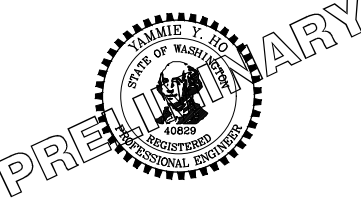
City Engineer _____	Date _____
Community Development _____	Date _____

**60 % REVIEW SUBMITTAL**  
NOT FOR CONSTRUCTION

REVISIONS	DATE	BY	DESIGNED
			M. TSUN
			B. PURGANAN
			P. JOHANNESSEN
			Y. HO

**ONE INCH AT FULL SCALE, IF NOT, SCALE ACCORDINGLY**

FILE NAME: BL1521075P19T03AL-04  
 JOB No: 554-1521-075 P19 T03  
 DATE: SEPTEMBER 2016



**Parametrix**  
ENGINEERING · PLANNING · ENVIRONMENTAL SCIENCES

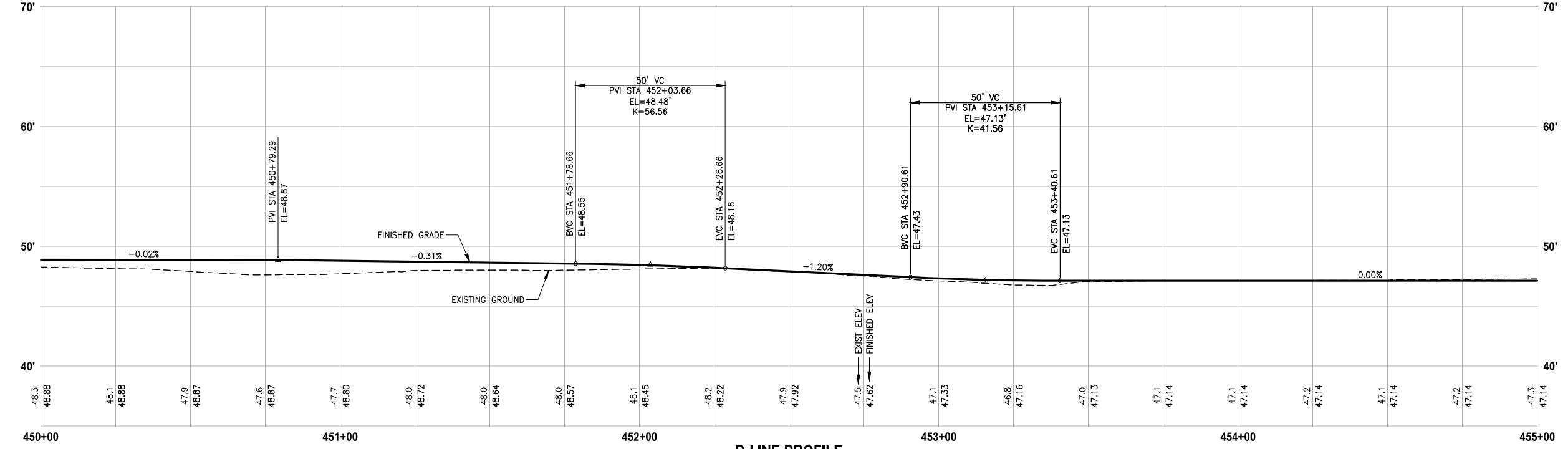
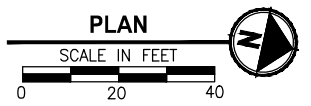
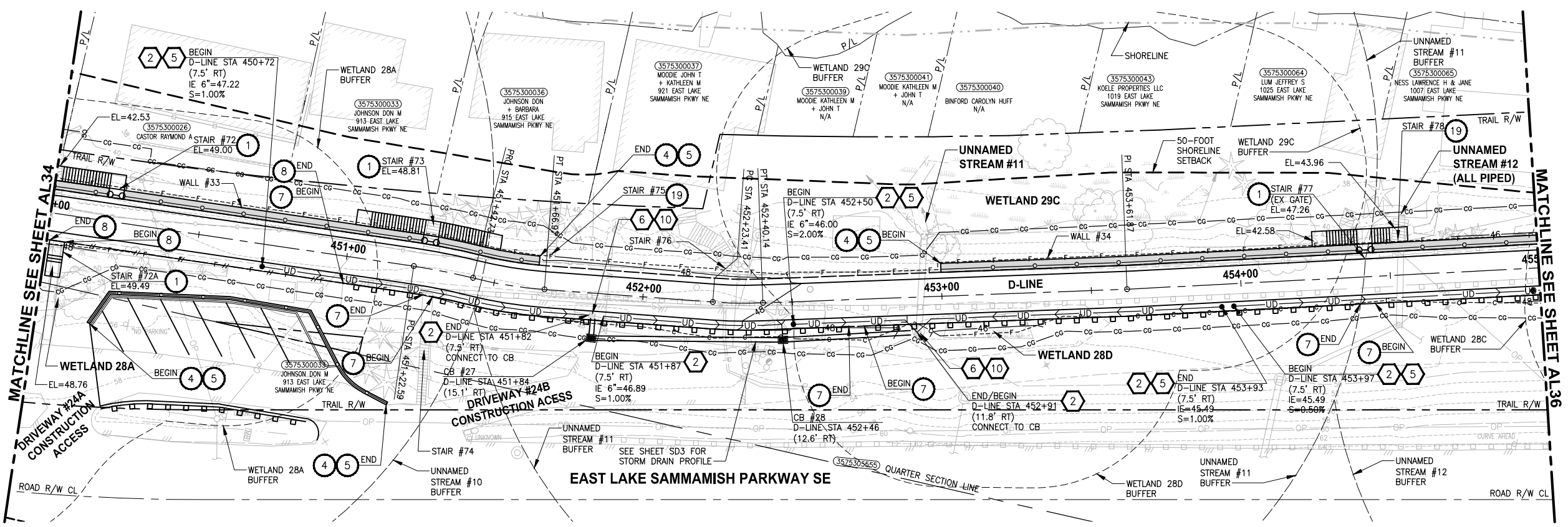
719 2ND AVENUE, SUITE 200 | SEATTLE, WA 98104  
 P 206.394.3700  
 WWW.PARAMETRIX.COM

PROJECT NAME  
**EAST LAKE SAMMAMISH MASTER PLAN TRAIL SOUTH SAMMAMISH SEGMENT B**  
 SAMMAMISH, WA

**PLAN AND PROFILE**

SHEET NO. 66 OF 135  
**AL34**

LAYOUT: AL35  
 PATH: U:\PSO\Projects\Clients\1521-KingCo\554-1521-075-ELST\995\CA\ADD\Phase 19\T03\_Civil\Draw\ PLOTTED BY: purgaban DATE: Wednesday, October 12, 2016 9:18:45 PM



**D-LINE PROFILE**  
 HORIZ: 1"=20'  
 VERT: 1"=5'

- CIVIL CONSTRUCTION NOTES:**
- RESTORE AND INSTALL STAIR. TYPE TO BE DETERMINED.
  - RECONSTRUCT PEDESTRIAN BRIDGE.
  - INSTALL PRECAST REINF CONC SPLIT BOX CULVERT. SEE FP SHEETS FOR DETAILS.
  - INSTALL STRUCTURAL EARTH WALL. SEE WALL DETAILS ON SHEET X. SEE WALL PROFILES ON WP SHEETS.
  - INSTALL COATED CHAIN LINK FENCE TYPE 6. FOR GROUND POST INSTALLATION SEE APPENDIX B IN THE SPECIFICATIONS. SEE SHEET X FOR MOUNTING ON TOP OF WALL.
  - NEW DRIVEWAY.
  - INSTALL WOOD GUARDRAIL, SEE DETAILS ON SHEET XX.
  - INSTALL SPLIT RAIL FENCE, SEE DETAILS ON SHEET XX.
  - INSTALL GRAVITY BLOCK WALL. SEE WALL DETAILS ON SHEET WD1. SEE WALL PROFILES ON WP SHEETS.
  - DRIVEWAY REMOVAL. SEE MP SHEETS FOR PLANTING PLAN.
  - INSTALL PATTERNED CONCRETE DRIVEWAY. SEE DETAILS ON SHEET XX.
  - INSTALL TYPE 1 REST STOP. SEE DETAILS ON SHEET XX.
  - INSTALL TYPE 2 REST STOP. SEE DETAILS ON SHEET XX.
  - INSTALL SOLDIER PILE WALL.
  - INSTALL GRAVITY BLOCK WALL.
  - INSTALL WING WALL. SEE FP SHEETS.
  - INSTALL EXTRUDED CURB PER WSDOT STD PLAN F-10.42-00.
  - REST STOP PULL-OUT.
  - STAIRS WILL BE ELIMINATED DURING CONSTRUCTION.
  - BRIDGES WILL BE REMOVED TO R/W LINE DURING CONSTRUCTION.
  - INSTALL ROCK WALL.

- STORMWATER CONSTRUCTION NOTES:**
- INFILTRATION TRENCH, SEE DETAIL 4 ON SHEET DD1.
  - UNDERDRAIN TRENCH, SEE DETAIL 5 ON SHEET DD1.
  - ROCK PAD, SEE DETAIL 2 ON SHEET DD1 AND WP SHEETS.
  - CONNECTION TO DRAINAGE STRUCTURE AND CLEANING EXISTING DRAINAGE STRUCTURE.
  - INSTALL UNDERDRAIN TRENCH CLEANOUT, SEE DETAIL 6 ON SHEET DD1.
  - INSTALL RECTANGULAR SLIP RESISTANT SOLID METAL COVER PER WSDOT STD DETAIL B-30.20-02.
  - CONCRETE HEADWALL, SEE DETAIL 1 ON SHEET DD1.
  - BASIC DISPERSION, SEE SHEET CS3.
  - QUARRY SPALL OUTFALL PROTECTION. SEE DETAIL 3 ON SHEET DD1.
  - ADJUST CATCH BASIN.

- LEGEND:**
- RETAINING WALL
  - SOLDIER PILE WALL
  - WOOD GUARDRAIL
  - DISPERSION AREA
  - DRIVEWAY REMOVAL

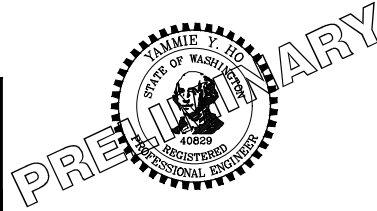
CITY OF SAMMAMISH APPROVAL	
City Engineer _____	Date _____
Community Development _____	Date _____

**60% REVIEW SUBMITTAL**  
 NOT FOR CONSTRUCTION

REVISIONS	DATE	BY	DESIGNED
			M. TSUN
			B. PURGANAN
			P. JOHANNESSEN
			Y. HO

**ONE INCH AT FULL SCALE, IF NOT, SCALE ACCORDINGLY**

FILE NAME: BL1521075P19T03AL-04  
 JOB No.: 554-1521-075 P19 T03  
 DATE: SEPTEMBER 2016



**Parametrix**  
 ENGINEERING · PLANNING · ENVIRONMENTAL SCIENCES

719 2ND AVENUE, SUITE 200 | SEATTLE, WA 98104  
 P 206.394.3700  
 WWW.PARAMETRIX.COM

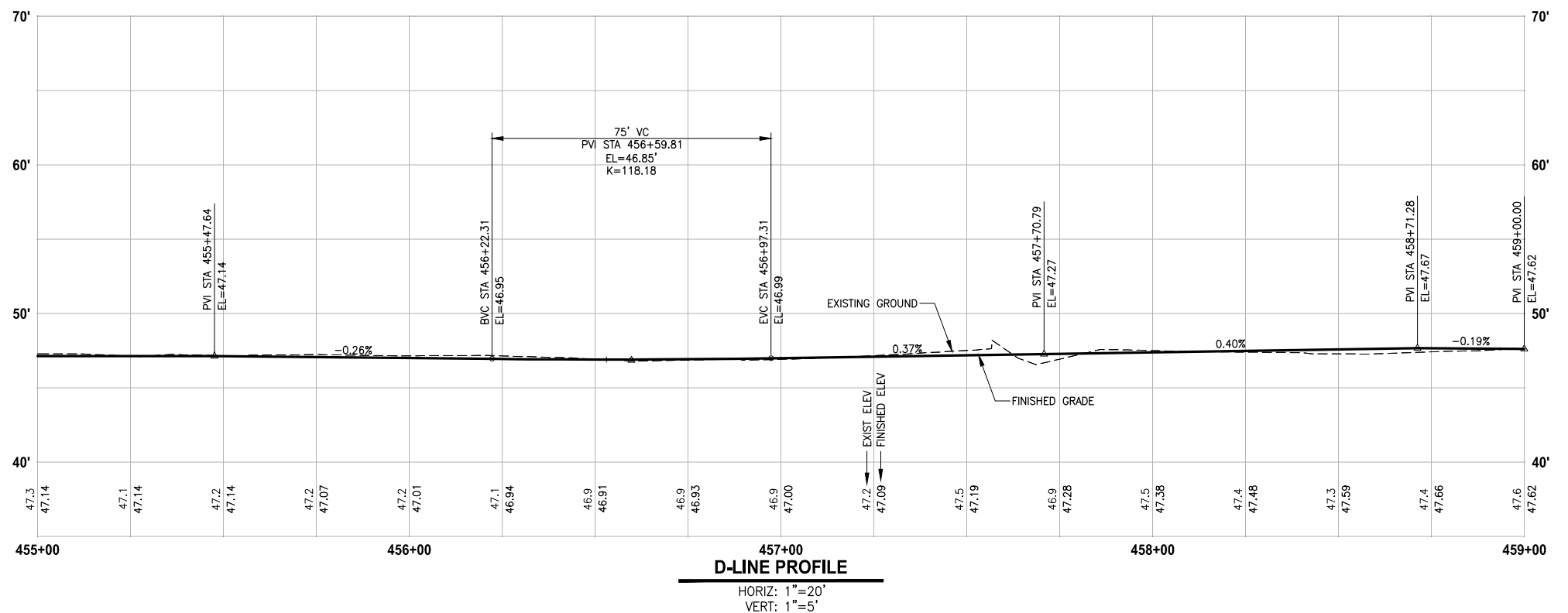
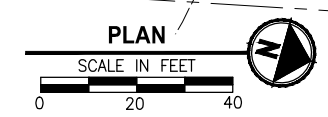
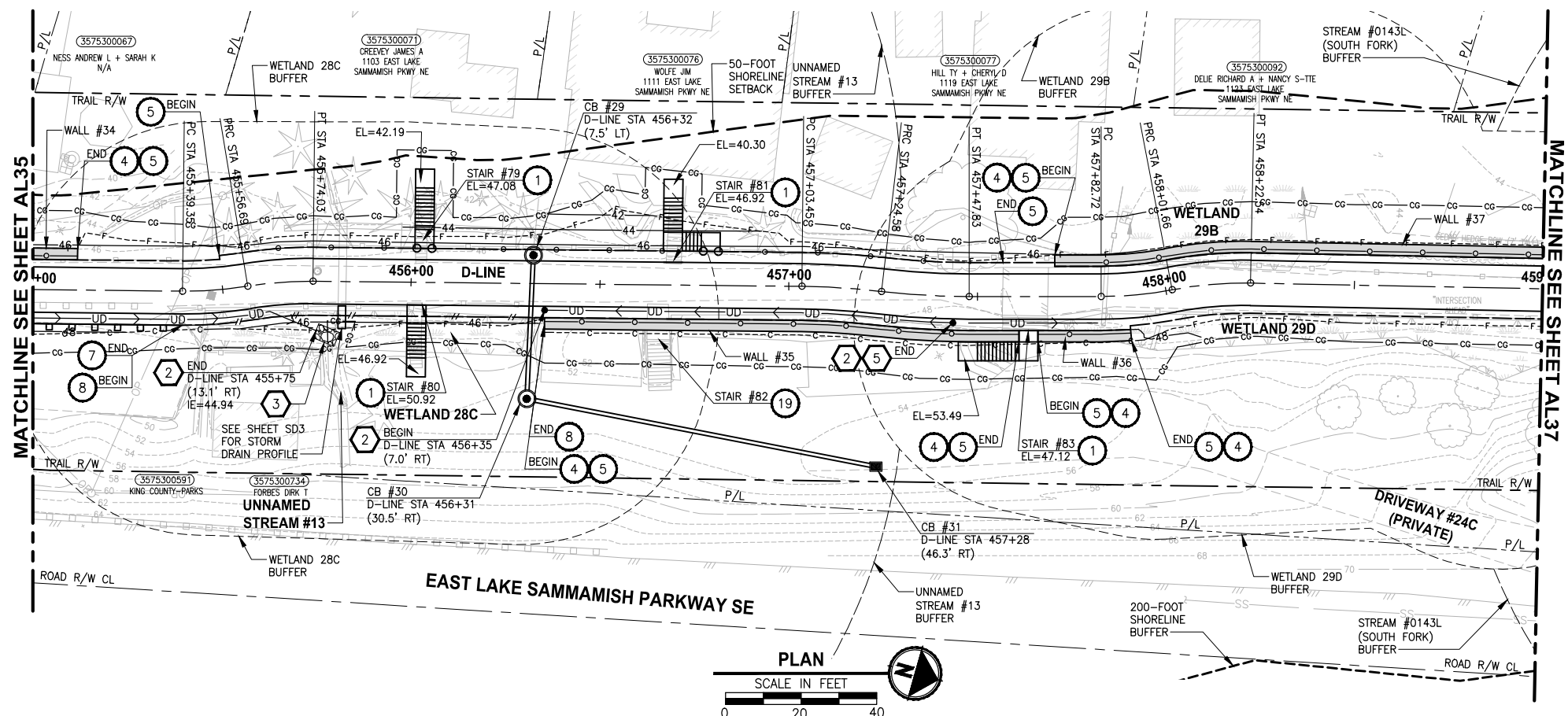
PROJECT NAME  
**EAST LAKE SAMMAMISH MASTER PLAN TRAIL SOUTH SAMMAMISH SEGMENT B**  
 SAMMAMISH, WA

**PLAN AND PROFILE**

SHEET NO. 67 OF 135  
**AL35**

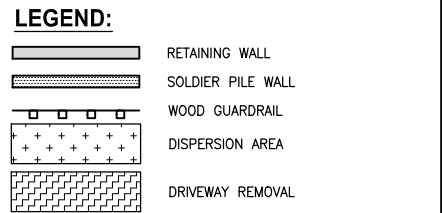


LAYOUT: AL36  
 PATH: U:\PSO\Projects\Clients\1521-KingCo\554-1521-075-ELST\995sca\CADD\Phase 19\T03\_Civil\Draw\ PLOTTED BY: purgabut DATE: Wednesday, October 12, 2016 9:19:17 PM



- CIVIL CONSTRUCTION NOTES:**
- 1 RESTORE AND INSTALL STAIR. TYPE TO BE DETERMINED.
  - 2 RECONSTRUCT PEDESTRIAN BRIDGE.
  - 3 INSTALL PRECAST REINF CONC SPLIT BOX CULVERT. SEE FP SHEETS FOR DETAILS.
  - 4 INSTALL STRUCTURAL EARTH WALL. SEE WALL DETAILS ON SHEET X. SEE WALL PROFILES ON WP SHEETS.
  - 5 INSTALL COATED CHAIN LINK FENCE TYPE 6. FOR GROUND POST INSTALLATION SEE APPENDIX B IN THE SPECIFICATIONS. SEE SHEET X FOR MOUNTING ON TOP OF WALL.
  - 6 NEW DRIVEWAY.
  - 7 INSTALL WOOD GUARDRAIL, SEE DETAILS ON SHEET XX.
  - 8 INSTALL SPLIT RAIL FENCE, SEE DETAILS ON SHEET XX.
  - 9 INSTALL GRAVITY BLOCK WALL. SEE WALL DETAILS ON SHEET WD1. SEE WALL PROFILES ON WP SHEETS.
  - 10 DRIVEWAY REMOVAL. SEE MP SHEETS FOR PLANTING PLAN.
  - 11 INSTALL PATTERNED CONCRETE DRIVEWAY. SEE DETAILS ON SHEET XX.
  - 12 INSTALL TYPE 1 REST STOP. SEE DETAILS ON SHEET XX.
  - 13 INSTALL TYPE 2 REST STOP. SEE DETAILS ON SHEET XX.
  - 14 INSTALL SOLDIER PILE WALL.
  - 15 INSTALL GRAVITY BLOCK WALL.
  - 16 INSTALL WING WALL. SEE FP SHEETS.
  - 17 INSTALL EXTRUDED CURB PER WSDOT STD PLAN F-10.42-00.
  - 18 REST STOP PULL-OUT.
  - 19 STAIRS WILL BE ELIMINATED DURING CONSTRUCTION.
  - 20 BRIDGES WILL BE REMOVED TO R/W LINE DURING CONSTRUCTION.
  - 21 INSTALL ROCK WALL.

- STORMWATER CONSTRUCTION NOTES:**
- 1 INFILTRATION TRENCH, SEE DETAIL 4 ON SHEET DD1.
  - 2 UNDERDRAIN TRENCH, SEE DETAIL 5 ON SHEET DD1.
  - 3 ROCK PAD, SEE DETAIL 2 ON SHEET DD1 AND WP SHEETS.
  - 4 CONNECTION TO DRAINAGE STRUCTURE AND CLEANING EXISTING DRAINAGE STRUCTURE.
  - 5 INSTALL UNDERDRAIN TRENCH CLEANOUT, SEE DETAIL 6 ON SHEET DD1.
  - 6 INSTALL RECTANGULAR SLIP RESISTANT SOLID METAL COVER PER WSDOT STD DETAIL B-30.20-02.
  - 7 CONCRETE HEADWALL, SEE DETAIL 1 ON SHEET DD1.
  - 8 BASIC DISPERSION, SEE SHEET CS3.
  - 9 QUARRY SPALL OUTFALL PROTECTION. SEE DETAIL 3 ON SHEET DD1.
  - 10 ADJUST CATCH BASIN.



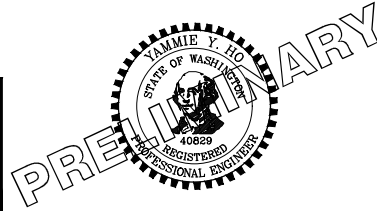
CITY OF SAMMAMISH APPROVAL	
City Engineer _____	Date _____
Community Development _____	Date _____

**60% REVIEW SUBMITTAL**  
NOT FOR CONSTRUCTION

REVISIONS	DATE	BY	DESIGNED
			M. TSUN
			B. PURGANAN
			P. JOHANNESSEN
			Y. HO

ONE INCH AT FULL SCALE.  
IF NOT, SCALE ACCORDINGLY

FILE NAME: BL1521075P19T03AL-04  
JOB No.: 554-1521-075 P19 T03  
DATE: SEPTEMBER 2016



**Parametrix**  
ENGINEERING · PLANNING · ENVIRONMENTAL SCIENCES

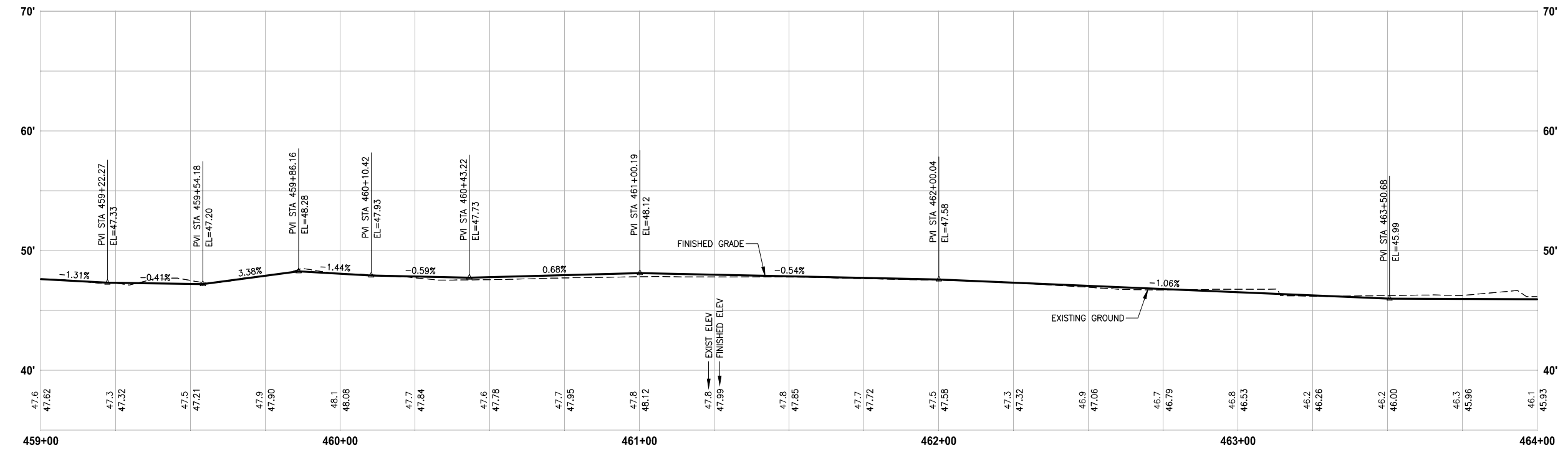
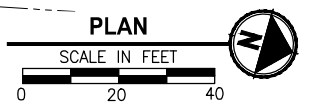
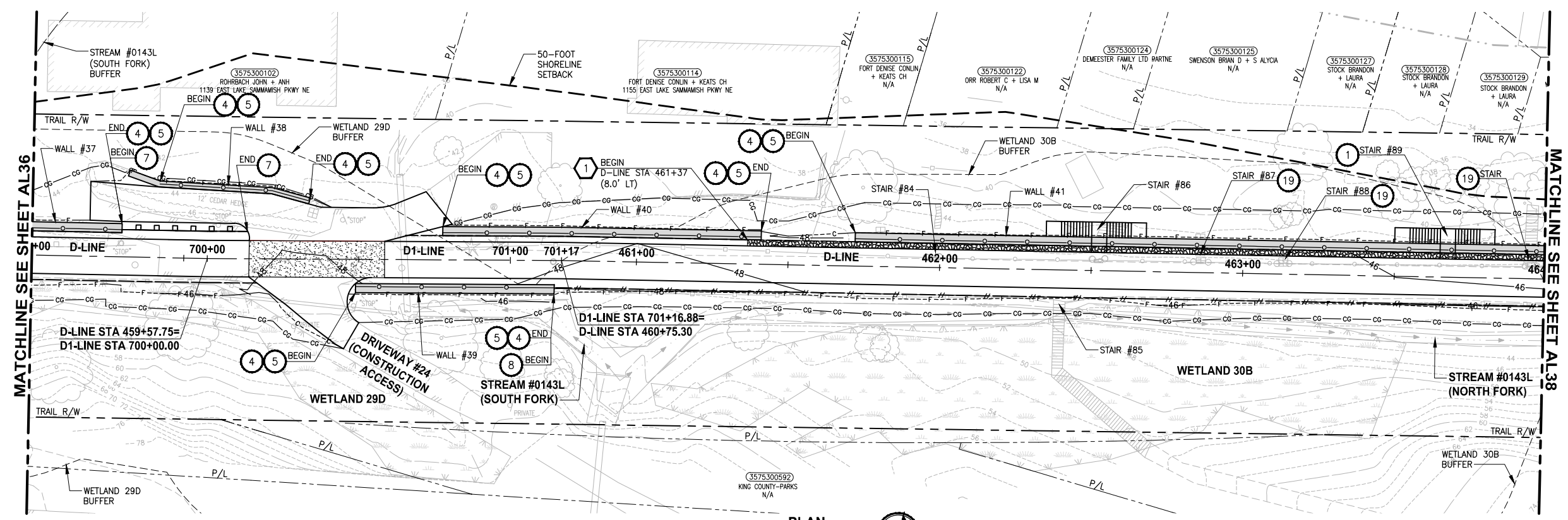
719 2ND AVENUE, SUITE 200 | SEATTLE, WA 98104  
P 206.394.3700  
WWW.PARAMETRIX.COM

PROJECT NAME  
**EAST LAKE SAMMAMISH  
MASTER PLAN TRAIL  
SOUTH SAMMAMISH SEGMENT B**  
SAMMAMISH, WA

**PLAN AND PROFILE**

SHEET NO.  
68 OF 135  
**AL36**

PATH: U:\PSO\Projects\Clients\1521-075-ELST\995\CA\ADD\Phase 19\T03\_Civil\Draw\ PLOTTED BY: purgaban DATE: Wednesday, October 12, 2016 9:19:47 PM LAYOUT: AL37

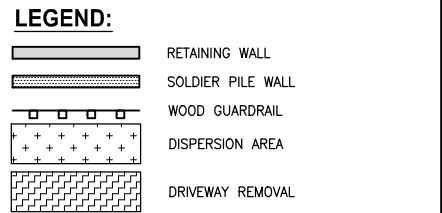


**D-LINE PROFILE**

HORIZ: 1"=20'  
VERT: 1"=5'

- CIVIL CONSTRUCTION NOTES:**
- 1 RESTORE AND INSTALL STAIR. TYPE TO BE DETERMINED.
  - 2 RECONSTRUCT PEDESTRIAN BRIDGE.
  - 3 INSTALL PRECAST REINF CONC SPLIT BOX CULVERT. SEE FP SHEETS FOR DETAILS.
  - 4 INSTALL STRUCTURAL EARTH WALL. SEE WALL DETAILS ON SHEET X. SEE WALL PROFILES ON WP SHEETS.
  - 5 INSTALL COATED CHAIN LINK FENCE TYPE 6. FOR GROUND POST INSTALLATION SEE APPENDIX B IN THE SPECIFICATIONS. SEE SHEET X FOR MOUNTING ON TOP OF WALL.
  - 6 NEW DRIVEWAY.
  - 7 INSTALL WOOD GUARDRAIL, SEE DETAILS ON SHEET XX.
  - 8 INSTALL SPLIT RAIL FENCE, SEE DETAILS ON SHEET XX.
  - 9 INSTALL GRAVITY BLOCK WALL. SEE WALL DETAILS ON SHEET WD1. SEE WALL PROFILES ON WP SHEETS.
  - 10 DRIVEWAY REMOVAL. SEE MP SHEETS FOR PLANTING PLAN.
  - 11 INSTALL PATTERNED CONCRETE DRIVEWAY. SEE DETAILS ON SHEET XX.
  - 12 INSTALL TYPE 1 REST STOP. SEE DETAILS ON SHEET XX.
  - 13 INSTALL TYPE 2 REST STOP. SEE DETAILS ON SHEET XX.
  - 14 INSTALL SOLDIER PILE WALL.
  - 15 INSTALL GRAVITY BLOCK WALL.
  - 16 INSTALL WING WALL. SEE FP SHEETS.
  - 17 INSTALL EXTRUDED CURB PER WSDOT STD PLAN F-10.42-00.
  - 18 REST STOP PULL-OUT.
  - 19 STAIRS WILL BE ELIMINATED DURING CONSTRUCTION.
  - 20 BRIDGES WILL BE REMOVED TO R/W LINE DURING CONSTRUCTION.
  - 21 INSTALL ROCK WALL.

- STORMWATER CONSTRUCTION NOTES:**
- 1 INFILTRATION TRENCH, SEE DETAIL 4 ON SHEET DD1.
  - 2 UNDERDRAIN TRENCH, SEE DETAIL 5 ON SHEET DD1.
  - 3 ROCK PAD, SEE DETAIL 2 ON SHEET DD1 AND WP SHEETS.
  - 4 CONNECTION TO DRAINAGE STRUCTURE AND CLEANING EXISTING DRAINAGE STRUCTURE.
  - 5 INSTALL UNDERDRAIN TRENCH CLEANOUT, SEE DETAIL 6 ON SHEET DD1.
  - 6 INSTALL RECTANGULAR SLIP RESISTANT SOLID METAL COVER PER WSDOT STD DETAIL B-30.20-02.
  - 7 CONCRETE HEADWALL, SEE DETAIL 1 ON SHEET DD1.
  - 8 BASIC DISPERSION, SEE SHEET CS3.
  - 9 QUARRY SPALL OUTFALL PROTECTION. SEE DETAIL 3 ON SHEET DD1.
  - 10 ADJUST CATCH BASIN.



**CITY OF SAMMAMISH APPROVAL**

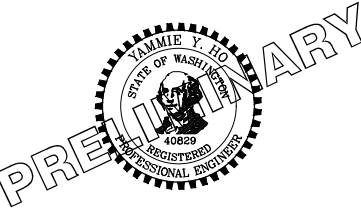
City Engineer _____	Date _____
Community Development _____	Date _____

**60 % REVIEW SUBMITTAL  
NOT FOR CONSTRUCTION**

REVISIONS	DATE	BY	DESIGNED
			M. TSUN
			B. PURGANAN
			P. JOHANNESSEN
			Y. HO

**ONE INCH AT FULL SCALE,  
IF NOT, SCALE ACCORDINGLY**

FILE NAME: BL1521075P19T03AL-04  
JOB No: 554-1521-075 P19 T03  
DATE: SEPTEMBER 2016



**Parametrix**  
ENGINEERING · PLANNING · ENVIRONMENTAL SCIENCES

719 2ND AVENUE, SUITE 200 | SEATTLE, WA 98104  
P 206.394.3700  
WWW.PARAMETRIX.COM

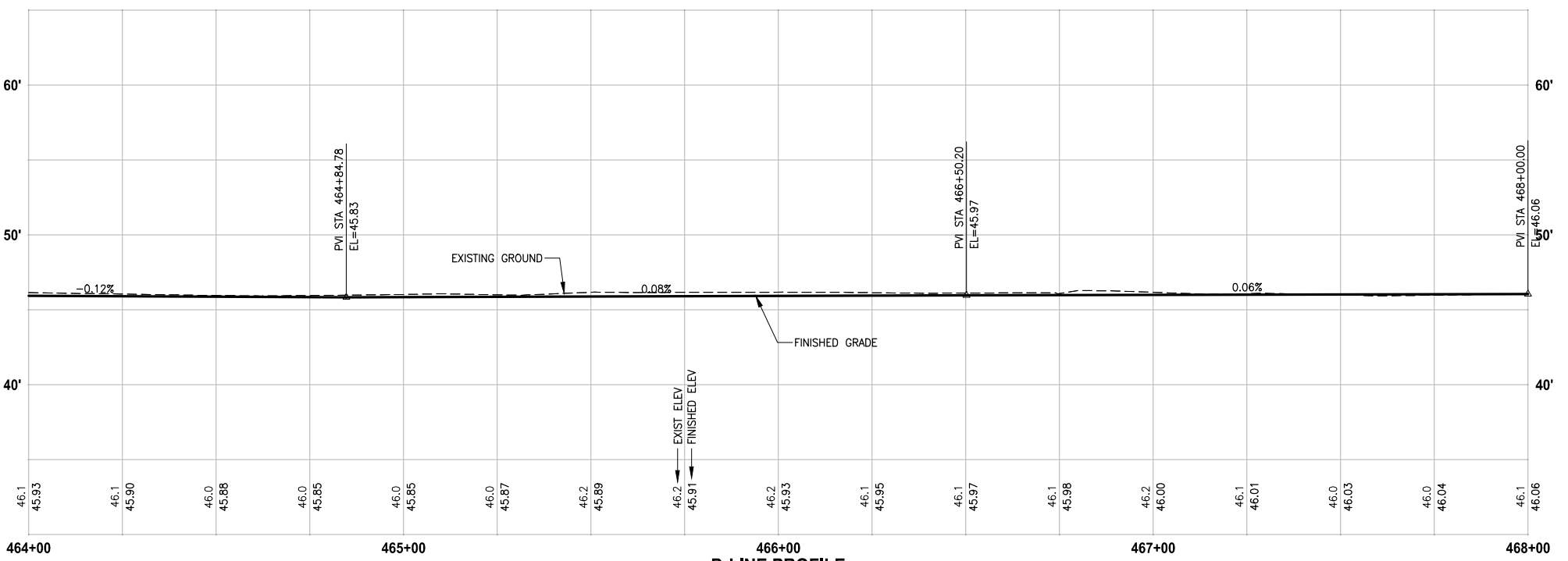
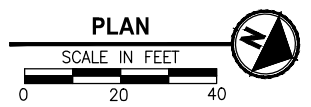
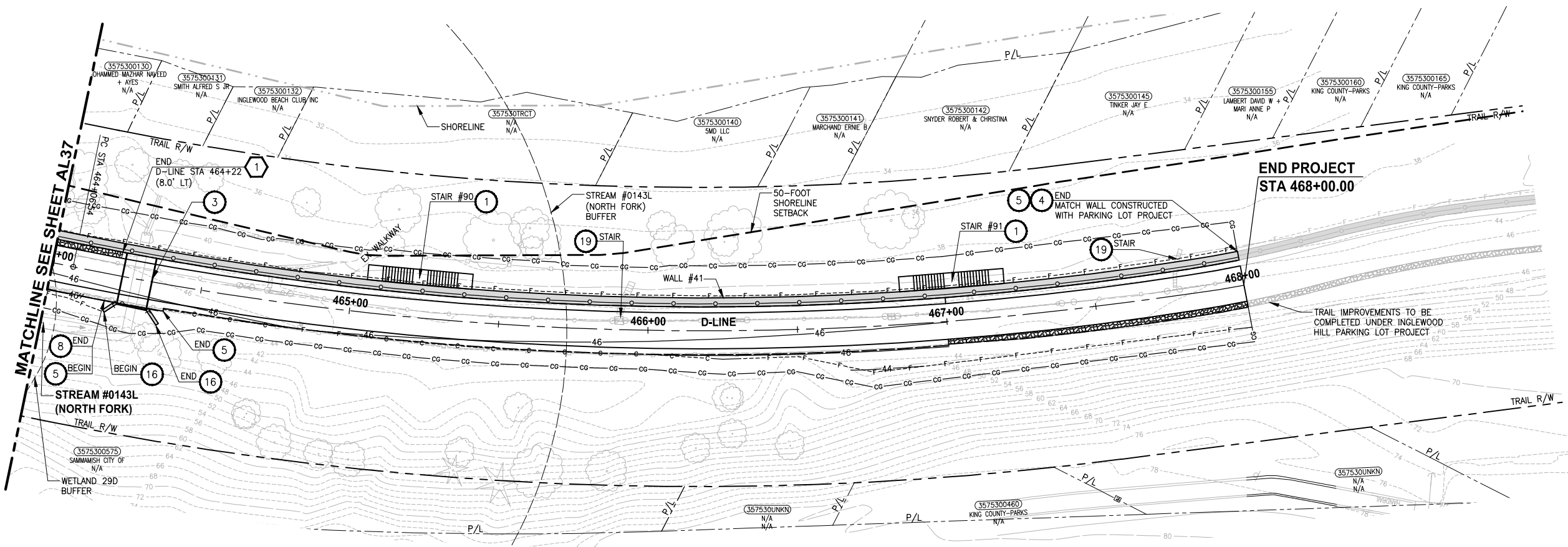
PROJECT NAME  
**EAST LAKE SAMMAMISH  
MASTER PLAN TRAIL  
SOUTH SAMMAMISH SEGMENT B**  
SAMMAMISH, WA

**PLAN AND PROFILE**

SHEET NO.  
69 OF 135  
**AL37**



LAYOUT: AL38    PATH: U:\PSO\Projects\Clients\1521-075-ELST\995\ca\ADD\Phase 19\103\_Civil\Draw\    PLOTTED BY: purgabut    DATE: Wednesday, October 12, 2016 9:20:16 PM



**D-LINE PROFILE**  
 HORIZ: 1"=20'  
 VERT: 1"=5'

**CIVIL CONSTRUCTION NOTES:**

- 1 RESTORE AND INSTALL STAIR. TYPE TO BE DETERMINED.
- 2 RECONSTRUCT PEDESTRIAN BRIDGE.
- 3 INSTALL PRECAST REINF CONC SPLIT BOX CULVERT. SEE FP SHEETS FOR DETAILS.
- 4 INSTALL STRUCTURAL EARTH WALL. SEE WALL DETAILS ON SHEET X. SEE WALL PROFILES ON WP SHEETS.
- 5 INSTALL COATED CHAIN LINK FENCE TYPE 6. FOR GROUND POST INSTALLATION SEE APPENDIX B IN THE SPECIFICATIONS. SEE SHEET X FOR MOUNTING ON TOP OF WALL.
- 6 NEW DRIVEWAY.
- 7 INSTALL WOOD GUARDRAIL, SEE DETAILS ON SHEET XX.
- 8 INSTALL SPLIT RAIL FENCE, SEE DETAILS ON SHEET XX.
- 9 INSTALL GRAVITY BLOCK WALL. SEE WALL DETAILS ON SHEET WD1. SEE WALL PROFILES ON WP SHEETS.
- 10 DRIVEWAY REMOVAL. SEE MP SHEETS FOR PLANTING PLAN.
- 11 INSTALL PATTERNED CONCRETE DRIVEWAY. SEE DETAILS ON SHEET XX.
- 12 INSTALL TYPE 1 REST STOP. SEE DETAILS ON SHEET XX.
- 13 INSTALL TYPE 2 REST STOP. SEE DETAILS ON SHEET XX.
- 14 INSTALL SOLDIER PILE WALL.
- 15 INSTALL GRAVITY BLOCK WALL.
- 16 INSTALL WING WALL, SEE FP SHEETS.
- 17 INSTALL EXTRUDED CURB PER WSDOT STD PLAN F-10.42-00.
- 18 REST STOP PULL-OUT.
- 19 STAIRS WILL BE ELIMINATED DURING CONSTRUCTION.
- 20 BRIDGES WILL BE REMOVED TO R/W LINE DURING CONSTRUCTION.
- 21 INSTALL ROCK WALL.

**STORMWATER CONSTRUCTION NOTES:**

- 1 INFILTRATION TRENCH, SEE DETAIL 4 ON SHEET DD1.
- 2 UNDERDRAIN TRENCH, SEE DETAIL 5 ON SHEET DD1.
- 3 ROCK PAD, SEE DETAIL 2 ON SHEET DD1 AND WP SHEETS.
- 4 CONNECTION TO DRAINAGE STRUCTURE AND CLEANING EXISTING DRAINAGE STRUCTURE.
- 5 INSTALL UNDERDRAIN TRENCH CLEANOUT, SEE DETAIL 6 ON SHEET DD1.
- 6 INSTALL RECTANGULAR SLIP RESISTANT SOLID METAL COVER PER WSDOT STD DETAIL B-30.20-02.
- 7 CONCRETE HEADWALL, SEE DETAIL 1 ON SHEET DD1.
- 8 BASIC DISPERSION, SEE SHEET CS3.
- 9 QUARRY SPALL OUTFALL PROTECTION. SEE DETAIL 3 ON SHEET DD1.
- 10 ADJUST CATCH BASIN.

**LEGEND:**

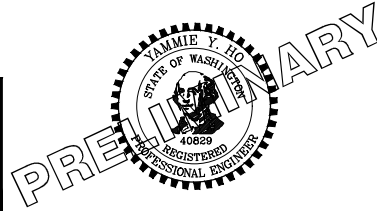
- RETAINING WALL
- SOLDIER PILE WALL
- WOOD GUARDRAIL
- DISPERSION AREA
- DRIVEWAY REMOVAL

CITY OF SAMMAMISH APPROVAL	
City Engineer _____	Date _____
Community Development _____	Date _____

**60 % REVIEW SUBMITTAL**  
 NOT FOR CONSTRUCTION

REVISIONS	DATE	BY	DESIGNED
			M. TSUN
			B. PURGANAN
			P. JOHANNESSEN
			Y. HO

ONE INCH AT FULL SCALE.  
 IF NOT, SCALE ACCORDINGLY.  
 FILE NAME: BL1521075P19T03AL-04  
 JOB No: 554-1521-075 P19 T03  
 DATE: SEPTEMBER 2016



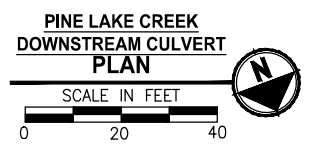
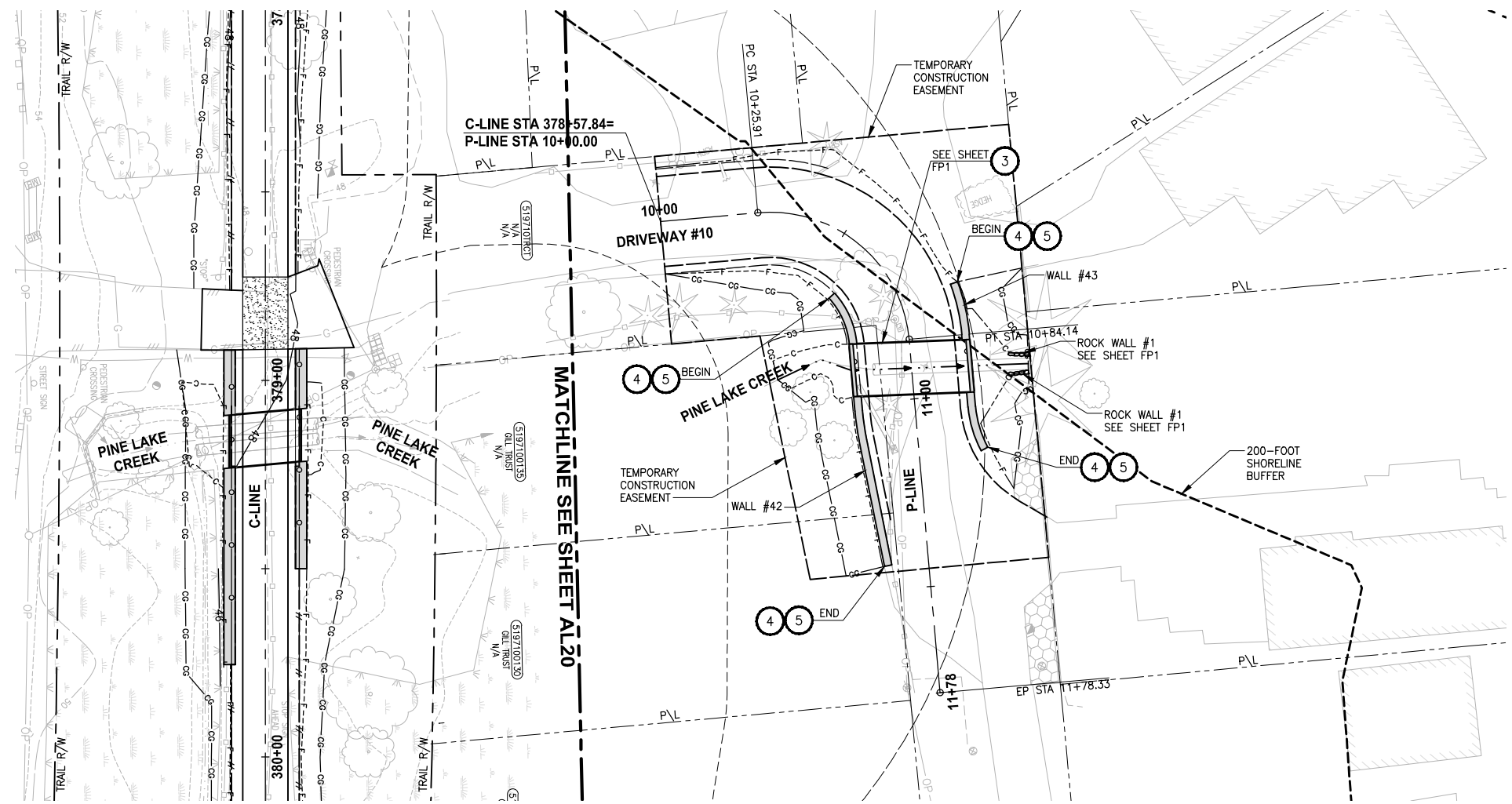
**Parametrix**  
 ENGINEERING · PLANNING · ENVIRONMENTAL SCIENCES  
 719 2ND AVENUE, SUITE 200 | SEATTLE, WA 98104  
 P 206.394.3700  
 WWW.PARAMETRIX.COM

PROJECT NAME  
**EAST LAKE SAMMAMISH  
 MASTER PLAN TRAIL  
 SOUTH SAMMAMISH SEGMENT B**  
 SAMMAMISH, WA

**PLAN AND PROFILE**

SHEET NO.  
 70 OF 135  
**AL38**

LAYOUT: AL39 PATH: U:\FS0\Projects\Clients\1521-KingCo\554-1521-075-ELST\995sca\CaDD\Phase 19\T03\_Civil\Draw\ PLOTTED BY: purgabut DATE: Wednesday, October 12, 2016 9:20:43 PM



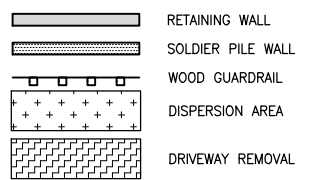
**CIVIL CONSTRUCTION NOTES:**

- 1 RESTORE AND INSTALL STAIR. TYPE TO BE DETERMINED.
- 2 RECONSTRUCT PEDESTRIAN BRIDGE.
- 3 INSTALL PRECAST REINF CONC SPLIT BOX CULVERT. SEE FP SHEETS FOR DETAILS.
- 4 INSTALL STRUCTURAL EARTH WALL. SEE WALL DETAILS ON SHEET X. SEE WALL PROFILES ON WP SHEETS.
- 5 INSTALL COATED CHAIN LINK FENCE TYPE 6. FOR GROUND POST INSTALLATION SEE APPENDIX B IN THE SPECIFICATIONS. SEE SHEET X FOR MOUNTING ON TOP OF WALL.
- 6 NEW DRIVEWAY.
- 7 INSTALL WOOD GUARDRAIL, SEE DETAILS ON SHEET XX.
- 8 INSTALL SPLIT RAIL FENCE, SEE DETAILS ON SHEET XX.
- 9 INSTALL GRAVITY BLOCK WALL. SEE WALL DETAILS ON SHEET WD1. SEE WALL PROFILES ON WP SHEETS.
- 10 DRIVEWAY REMOVAL. SEE MP SHEETS FOR PLANTING PLAN.
- 11 INSTALL PATTERNED CONCRETE DRIVEWAY. SEE DETAILS ON SHEET XX.
- 12 INSTALL TYPE 1 REST STOP. SEE DETAILS ON SHEET XX.
- 13 INSTALL TYPE 2 REST STOP. SEE DETAILS ON SHEET XX.
- 14 INSTALL SOLDIER PILE WALL.
- 15 INSTALL GRAVITY BLOCK WALL.
- 16 INSTALL WING WALL, SEE FP SHEETS.
- 17 INSTALL EXTRUDED CURB PER WSDOT STD PLAN F-10.42-00.
- 18 REST STOP PULL-OUT.
- 19 STAIRS WILL BE ELIMINATED DURING CONSTRUCTION.
- 20 BRIDGES WILL BE REMOVED TO R/W LINE DURING CONSTRUCTION.
- 21 INSTALL ROCK WALL.

**STORMWATER CONSTRUCTION NOTES:**

- 1 INFILTRATION TRENCH, SEE DETAIL 4 ON SHEET DD1.
- 2 UNDERDRAIN TRENCH, SEE DETAIL 5 ON SHEET DD1.
- 3 ROCK PAD, SEE DETAIL 2 ON SHEET DD1 AND WP SHEETS.
- 4 CONNECTION TO DRAINAGE STRUCTURE AND CLEANING EXISTING DRAINAGE STRUCTURE.
- 5 INSTALL UNDERDRAIN TRENCH CLEANOUT, SEE DETAIL 6 ON SHEET DD1.
- 6 INSTALL RECTANGULAR SLIP RESISTANT SOLID METAL COVER PER WSDOT STD DETAIL B-30.20-02.
- 7 CONCRETE HEADWALL, SEE DETAIL 1 ON SHEET DD1.
- 8 BASIC DISPERSION, SEE SHEET CS3.
- 9 QUARRY SPALL OUTFALL PROTECTION. SEE DETAIL 3 ON SHEET DD1.
- 10 ADJUST CATCH BASIN.

**LEGEND:**

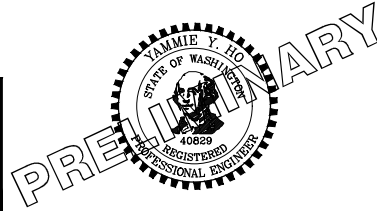


CITY OF SAMMAMISH APPROVAL	
City Engineer _____	Date _____
Community Development _____	Date _____

**60 % REVIEW SUBMITTAL  
NOT FOR CONSTRUCTION**

REVISIONS	DATE	BY	DESIGNED
			M. TSUN
			B. PURGANAN
			P. JOHANNESSEN
			Y. HO

ONE INCH AT FULL SCALE, IF NOT, SCALE ACCORDINGLY  
 FILE NAME: BL1521075P19T03AL-04  
 JOB No.: 554-1521-075 P19 T03  
 DATE: SEPTEMBER 2016



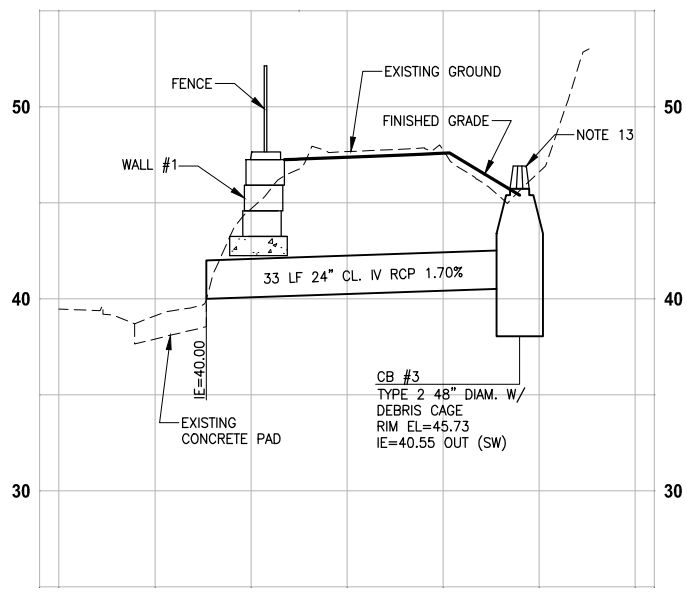
**Parametrix**  
 ENGINEERING · PLANNING · ENVIRONMENTAL SCIENCES  
 719 2ND AVENUE, SUITE 200 | SEATTLE, WA 98104  
 P 206.394.3700  
 WWW.PARAMETRIX.COM

PROJECT NAME  
**EAST LAKE SAMMAMISH  
 MASTER PLAN TRAIL  
 SOUTH SAMMAMISH SEGMENT B**  
 SAMMAMISH, WA

**PLAN AND PROFILE**

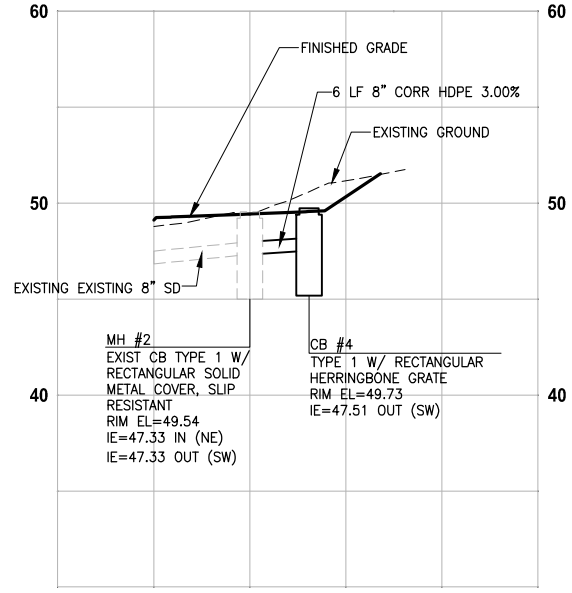
SHEET NO.  
71 OF 135  
  
**AL39**

PATH: U:\P50\Projects\Clients\1521-KingCo\554-1521-075-ELST\985\CA00\Phase 19\103\_Civil\DWG\ LAYOUT: SD1  
 PLOTTED BY: purgaban DATE: Wednesday, October 12, 2016 9:23:32 PM



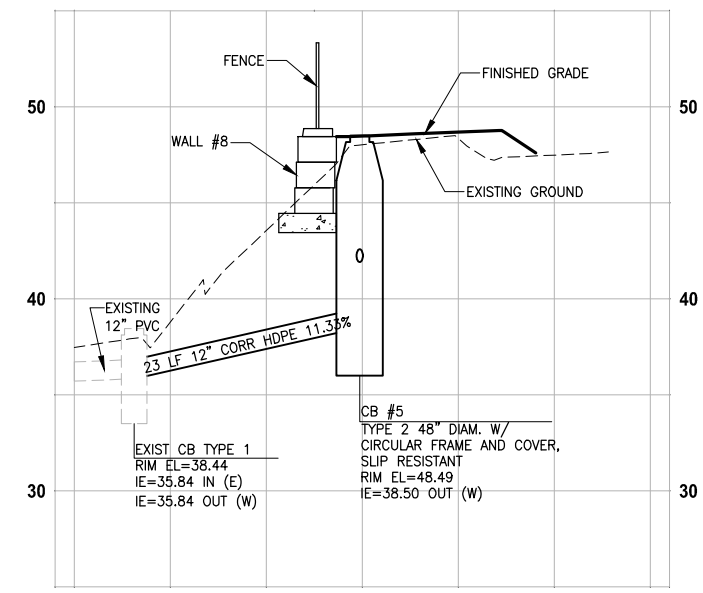
**PROFILE - STA 290+30**

HORIZ: 1"=10'  
VERT: 1"=5'



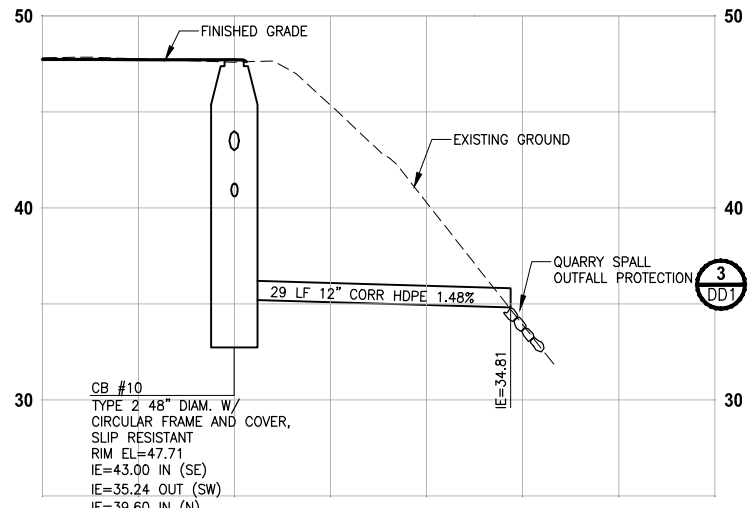
**PROFILE - STA 298+83**

HORIZ: 1"=10'  
VERT: 1"=5'



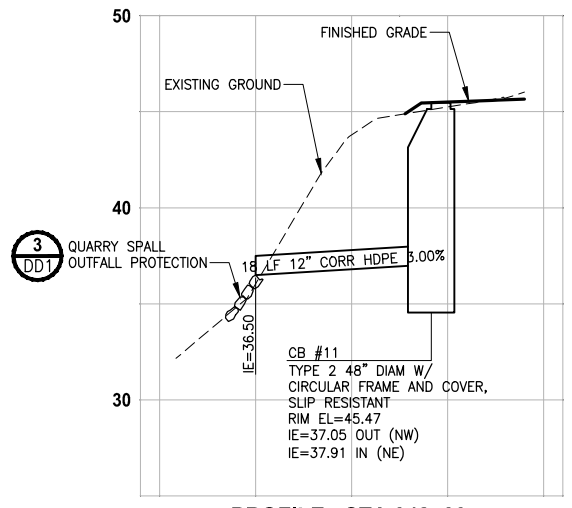
**PROFILE - STA 314+47**

HORIZ: 1"=10'  
VERT: 1"=5'



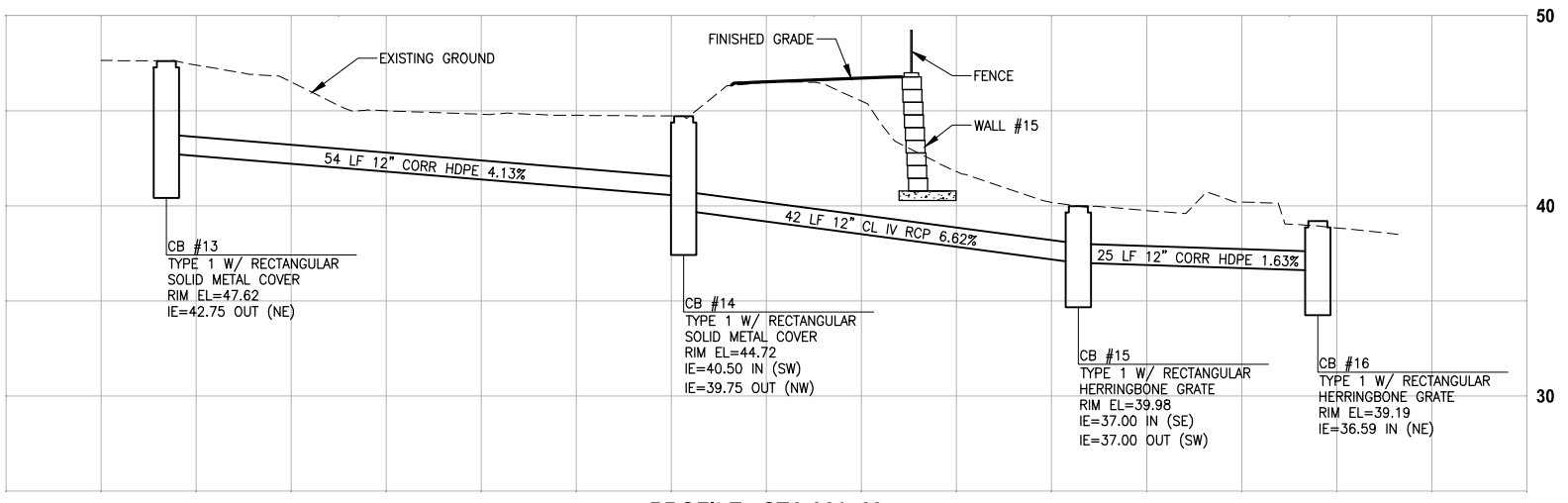
**PROFILE - STA 328+65**

HORIZ: 1"=10'  
VERT: 1"=5'



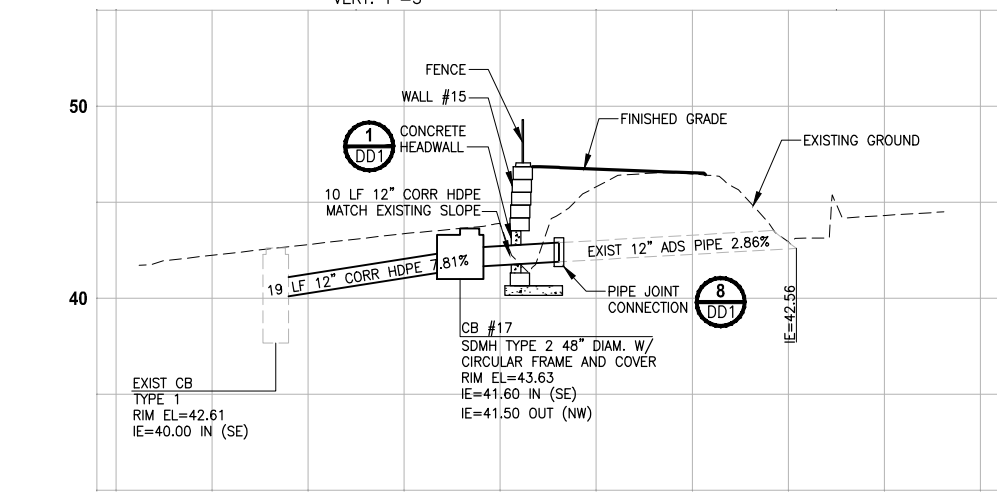
**PROFILE - STA 342+00**

HORIZ: 1"=10'  
VERT: 1"=5'



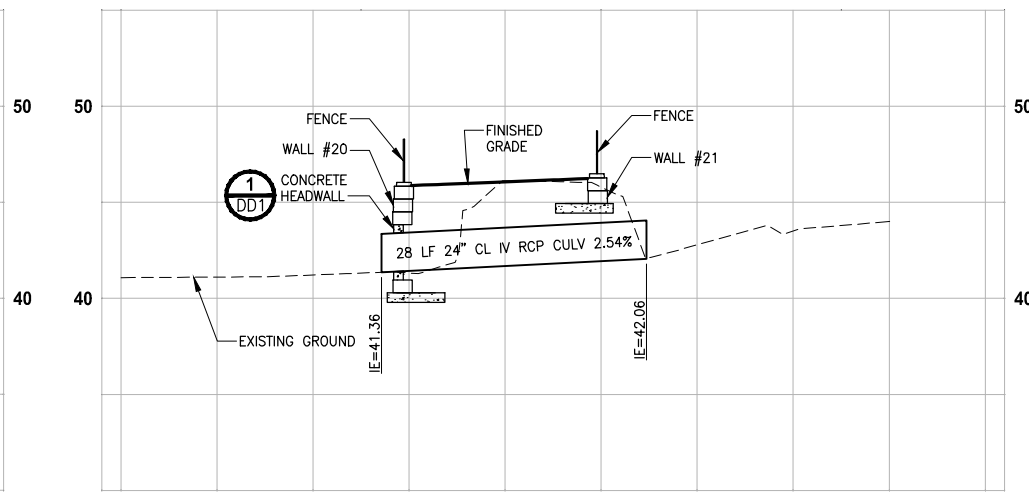
**PROFILE - STA 361+60**

HORIZ: 1"=10'  
VERT: 1"=5'



**PROFILE - STA 367+00**

HORIZ: 1"=10'  
VERT: 1"=5'



**PROFILE - STA 384+25**

HORIZ: 1"=10'  
VERT: 1"=5'

**GENERAL NOTES:**

- CULVERTS SHALL HAVE BEVELED END SECTIONS PER 2007 KCRS FIG. 7-001.
- STRUCTURE OFFSETS ARE MEASURED TO CENTER OF GRATE.
- CATCH BASIN TYPE 1 SHALL BE PER 2007 KCRS FIG. 7-003.
- CATCH BASIN TYPE 2 SHALL BE PER 2007 KCRS FIG. 7-005 AND FIG. 7-006.
- CIRCULAR FRAME (RING) AND COVER SHALL BE PER 2007 KCRS FIG. 7-022, AND FIG. 7-023.
- RECTANGULAR SOLID METAL COVER SHALL BE PER 2007 KCRS FIG. 7-014 AND FIG. 7-015.
- CL IV RCP = CLASS IV REINFORCED CONCRETE STORM SEWER PIPE.
- CORR HDPE = CORRUGATED HIGH DENSITY POLYETHYLENE STORM SEWER PIPE.
- RECTANGULAR HERRINGBONE GRATES SHALL BE PER 2007 KCRS FIG. 7-013.
- MH TYPE 3 SHALL BE PER 2007 KCRS FIG. 7-009.
- CIRCULAR GRATE SHALL BE PER WSDOT STANDARD PLAN B-30.80-00.
- CONCRETE COLLAR SHALL BE PER WSDOT STANDARD PLAN B-60.20-00.
- DEBRIS CAGE SHALL BE PER 2007 KCRS FIG. 7-028.

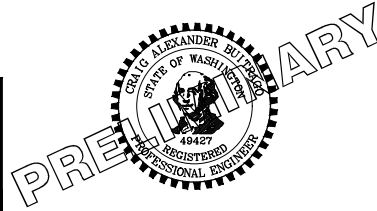
CITY OF SAMMAMISH APPROVAL	
City Engineer _____	Date _____
Community Development _____	Date _____

**60 % REVIEW SUBMITTAL**  
NOT FOR CONSTRUCTION

REVISIONS	DATE	BY	DESIGNED
			C. BUITRAGO
			B. PURGANAN
			P. JOHANNESSEN
			Y. HO

**ONE INCH AT FULL SCALE, IF NOT, SCALE ACCORDINGLY**

FILE NAME: BL1521075P19T03SD-01  
 JOB No: 554-1521-075 P19 T03  
 DATE: SEPTEMBER 2016



**Parametrix**  
 ENGINEERING · PLANNING · ENVIRONMENTAL SCIENCES

719 2ND AVENUE, SUITE 200 | SEATTLE, WA 98104  
 P 206.394.3700  
 WWW.PARAMETRIX.COM

PROJECT NAME  
**EAST LAKE SAMMAMISH MASTER PLAN TRAIL SOUTH SAMMAMISH SEGMENT B**  
 SAMMAMISH, WA

**STORM DRAINAGE PROFILES AND SECTIONS**

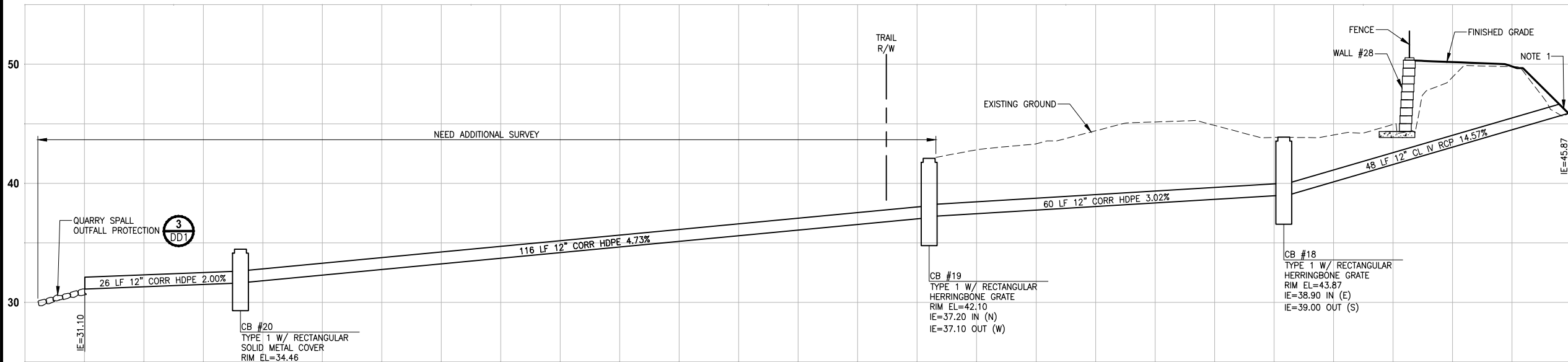
SHEET NO.  
72 OF 135

**SD1**

PATH: U:\PSO\Projects\Clients\1521-KingCo\554-1521-075-ELST\99Sves\CADD\Phase 19\T03\_Civil\Drawg\ PLOTTED BY: purganbut DATE: Wednesday, October 12, 2016 9:23:49 PM LAYOUT: SD2

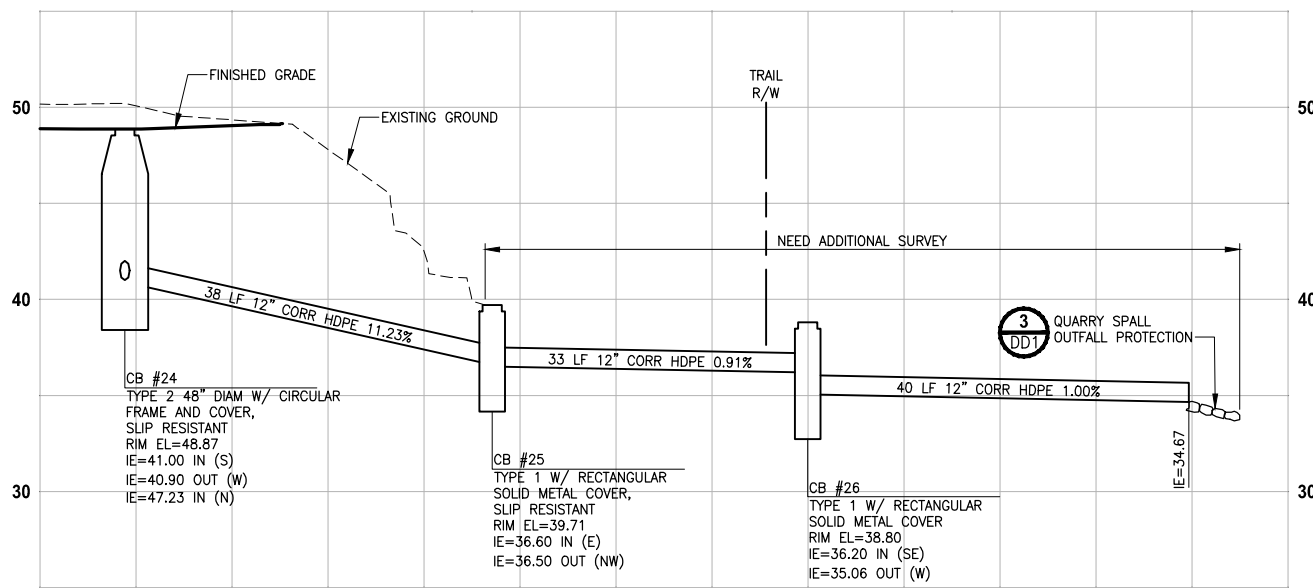
**GENERAL NOTES:**

- CULVERTS SHALL HAVE BEVELED END SECTIONS PER 2007 KCRS FIG. 7-001.
- STRUCTURE OFFSETS ARE MEASURED TO CENTER OF GRATE.
- CATCH BASIN TYPE 1 SHALL BE PER 2007 KCRS FIG. 7-003.
- CATCH BASIN TYPE 2 SHALL BE PER 2007 KCRS FIG. 7-005 AND FIG. 7-006.
- CIRCULAR FRAME (RING) AND COVER SHALL BE PER 2007 KCRS FIG. 7-022, AND FIG. 7-023.
- RECTANGULAR SOLID METAL COVER SHALL BE PER 2007 KCRS FIG. 7-014 AND FIG. 7-015.
- CL IV RCP = CLASS IV REINFORCED CONCRETE STORM SEWER PIPE.
- CORR HDPE = CORRUGATED HIGH DENSITY POLYETHYLENE STORM SEWER PIPE.
- RECTANGULAR HERRINGBONE GRATES SHALL BE PER 2007 KCRS FIG. 7-013.
- MH TYPE 3 SHALL BE PER 2007 KCRS FIG. 7-009.
- CIRCULAR GRATE SHALL BE PER WSDOT STANDARD PLAN B-30.80-00.
- CONCRETE COLLAR SHALL BE PER WSDOT STANDARD PLAN B-60.20-00.
- DEBRIS CAGE SHALL BE PER 2007 KCRS FIG. 7-028.



**PROFILE - STA 436+30**

HORIZ: 1"=10'  
VERT: 1"=5'



**PROFILE - STA 448+40**

HORIZ: 1"=10'  
VERT: 1"=5'

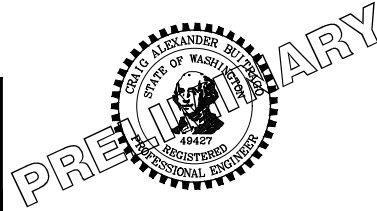
CITY OF SAMMAMISH APPROVAL	
City Engineer _____	Date _____
Community Development _____	Date _____

**60 % REVIEW SUBMITTAL**  
NOT FOR CONSTRUCTION

REVISIONS	DATE	BY	DESIGNED
			C. BUITRAGO
			B. PURGANAN
			P. JOHANNESSEN
			Y. HO

ONE INCH AT FULL SCALE, IF NOT, SCALE ACCORDINGLY

FILE NAME: BL1521075P19T03SD-01  
JOB No: 554-1521-075 P19 T03  
DATE: SEPTEMBER 2016



**Parametrix**  
ENGINEERING · PLANNING · ENVIRONMENTAL SCIENCES

719 2ND AVENUE, SUITE 200 | SEATTLE, WA 98104  
P 206.394.3700  
WWW.PARAMETRIX.COM

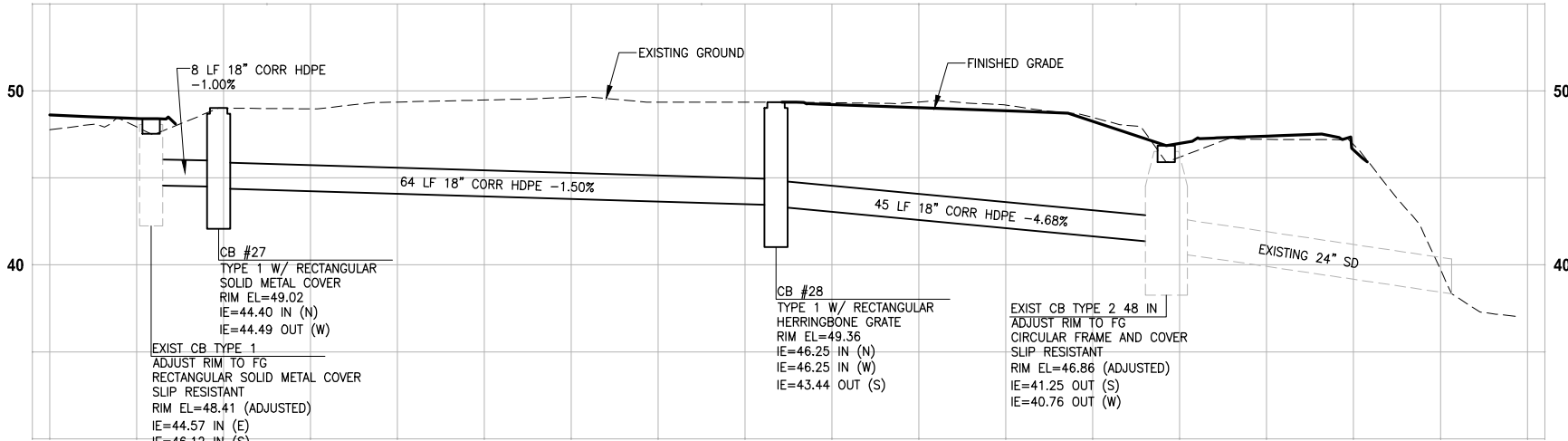
PROJECT NAME  
**EAST LAKE SAMMAMISH MASTER PLAN TRAIL SOUTH SAMMAMISH SEGMENT B**  
SAMMAMISH, WA

**STORM DRAINAGE PROFILES AND SECTIONS**

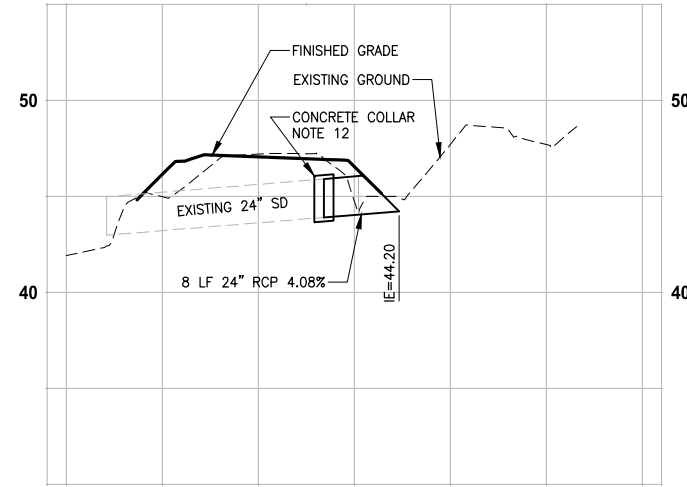
SHEET NO.  
73 OF 135  
**SD2**



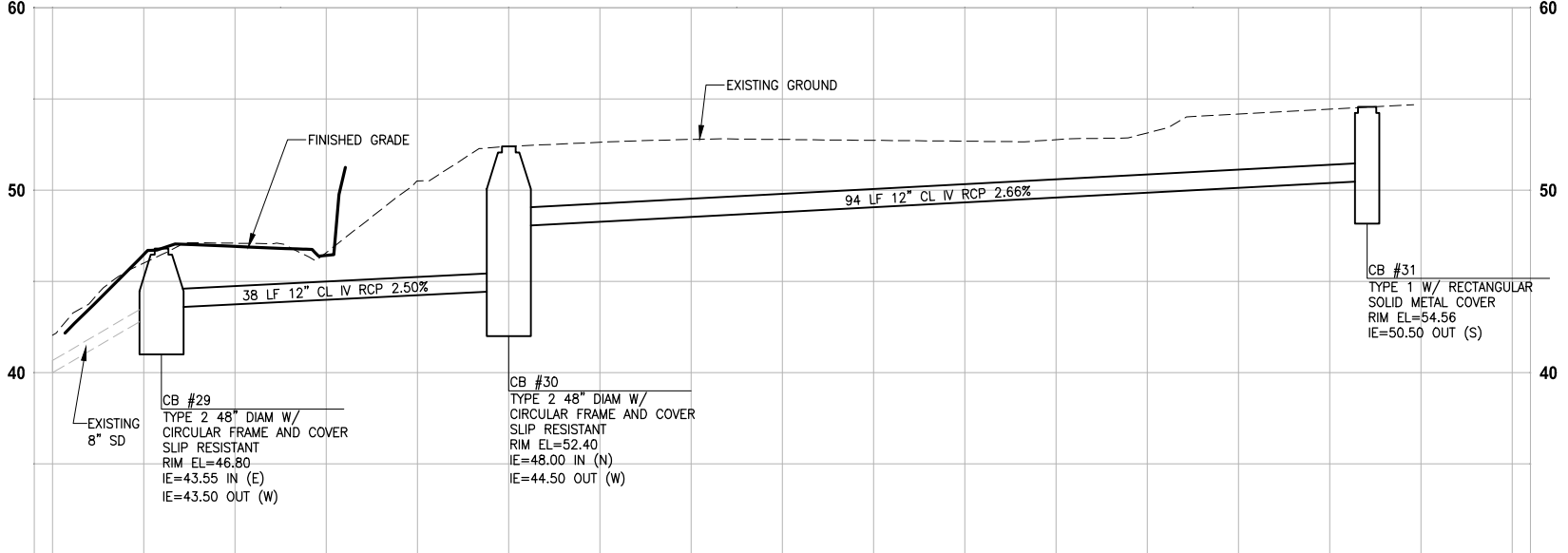
LAYOUT: SD3  
 PATH: U:\PSO\Projects\Clients\1521-KingCo\554-1521-075-ELST\99Sves\CADD\Phase 19\T03\_Civil\Draw\ PLOTTED BY: purganub DATE: Wednesday, October 12, 2016 9:24:05 PM



**PROFILE - STA 452+80**  
 HORIZ: 1"=10'  
 VERT: 1"=5'



**PROFILE - STA 455+75**  
 HORIZ: 1"=10'  
 VERT: 1"=5'



**PROFILE - STA 456+25**  
 HORIZ: 1"=10'  
 VERT: 1"=5'

**GENERAL NOTES:**

1. CULVERTS SHALL HAVE BEVELED END SECTIONS PER 2007 KCRS FIG. 7-001.
2. STRUCTURE OFFSETS ARE MEASURED TO CENTER OF GRATE.
3. CATCH BASIN TYPE 1 SHALL BE PER 2007 KCRS FIG. 7-003.
4. CATCH BASIN TYPE 2 SHALL BE PER 2007 KCRS FIG. 7-005 AND FIG. 7-006.
5. CIRCULAR FRAME (RING) AND COVER SHALL BE PER 2007 KCRS FIG. 7-022, AND FIG. 7-023.
6. RECTANGULAR SOLID METAL COVER SHALL BE PER 2007 KCRS FIG. 7-014 AND FIG. 7-015.
7. CL IV RCP = CLASS IV REINFORCED CONCRETE STORM SEWER PIPE.
8. CORR HDPE = CORRUGATED HIGH DENSITY POLYETHYLENE STORM SEWER PIPE.
9. RECTANGULAR HERRINGBONE GRATES SHALL BE PER 2007 KCRS FIG. 7-013.
10. MH TYPE 3 SHALL BE PER 2007 KCRS FIG. 7-009.
11. CIRCULAR GRATE SHALL BE PER WSDOT STANDARD PLAN B-30.80-00.
12. CONCRETE COLLAR SHALL BE PER WSDOT STANDARD PLAN B-60.20-00.
13. DEBRIS CAGE SHALL BE PER 2007 KCRS FIG. 7-028.

CITY OF SAMMAMISH APPROVAL	
City Engineer _____	Date _____
Community Development _____	Date _____

**60 % REVIEW SUBMITTAL**  
 NOT FOR CONSTRUCTION

REVISIONS	DATE	BY	DESIGNED
			C. BUITRAGO
			B. PURGANAN
			P. JOHANNESSEN
			Y. HO

**ONE INCH AT FULL SCALE, IF NOT, SCALE ACCORDINGLY**  
 FILE NAME: BL1521075P19T03SD-01  
 JOB No.: 554-1521-075 P19 T03  
 DATE: SEPTEMBER 2016



**Parametrix**  
 ENGINEERING · PLANNING · ENVIRONMENTAL SCIENCES  
 719 2ND AVENUE, SUITE 200 | SEATTLE, WA 98104  
 P 206.394.3700  
 WWW.PARAMETRIX.COM

PROJECT NAME  
**EAST LAKE SAMMAMISH MASTER PLAN TRAIL SOUTH SAMMAMISH SEGMENT B**  
 SAMMAMISH, WA

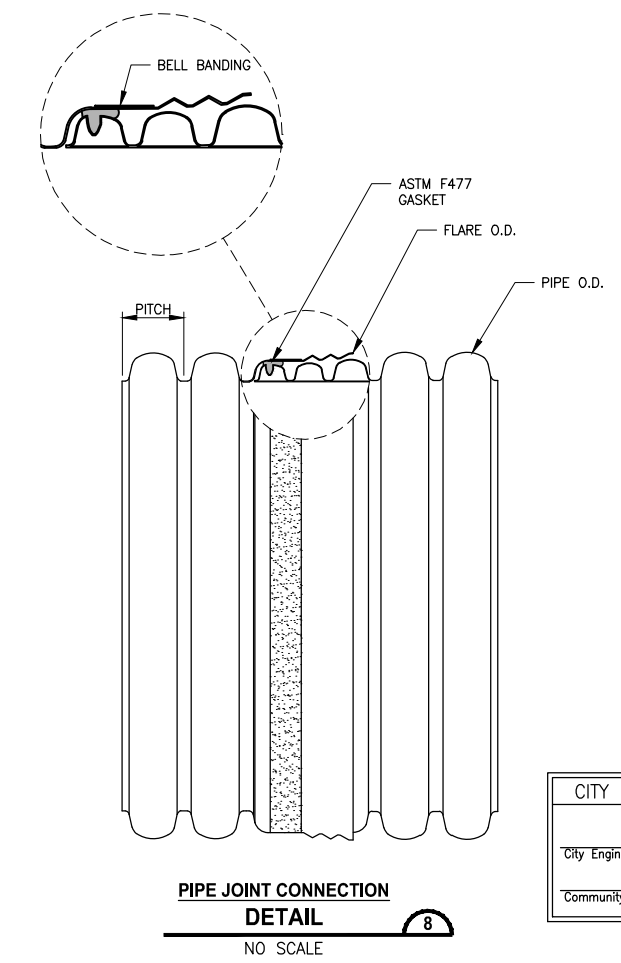
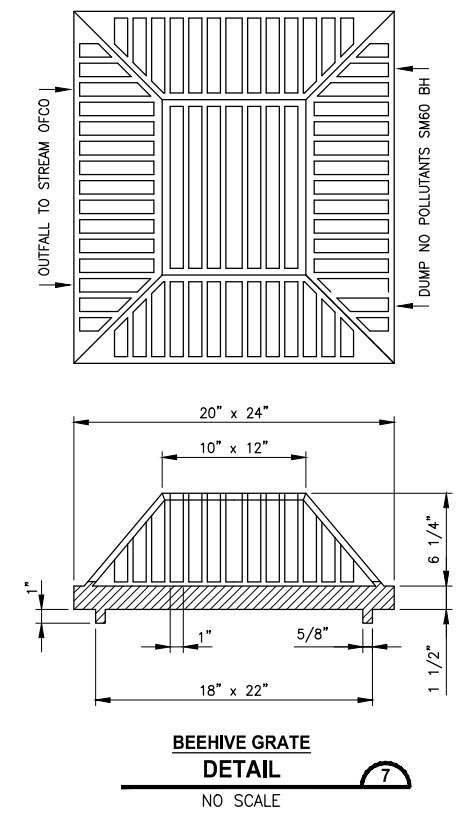
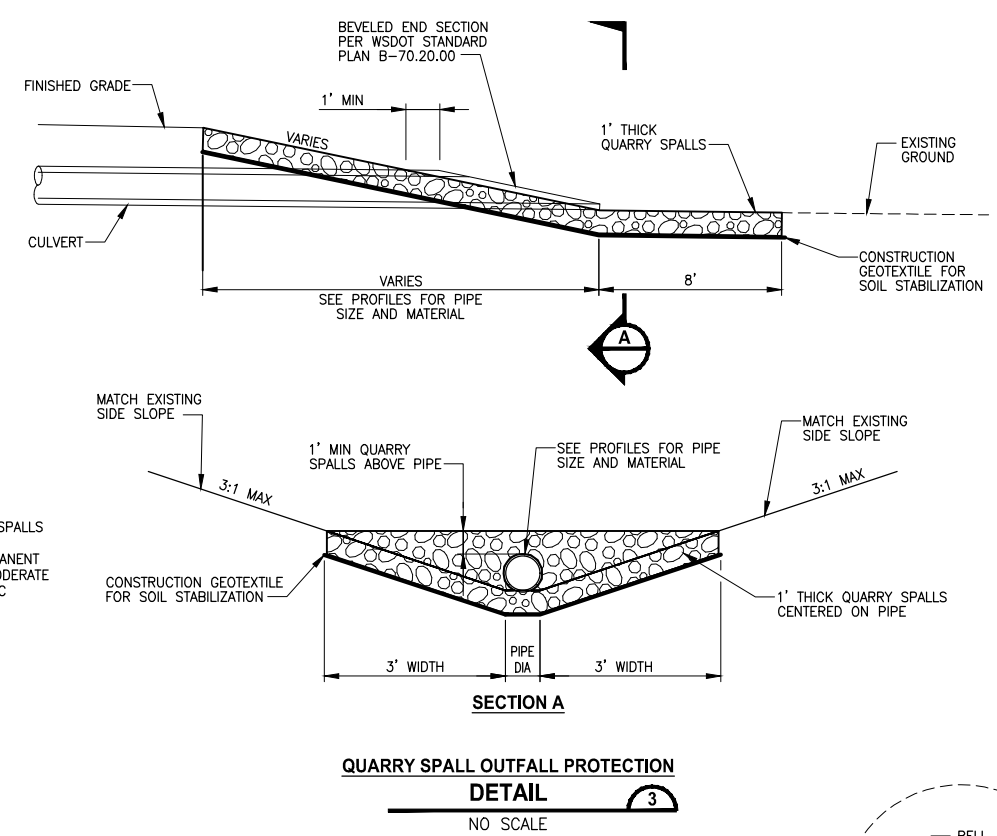
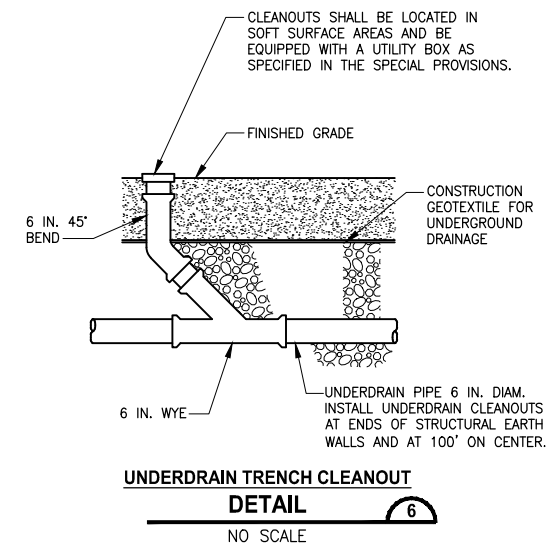
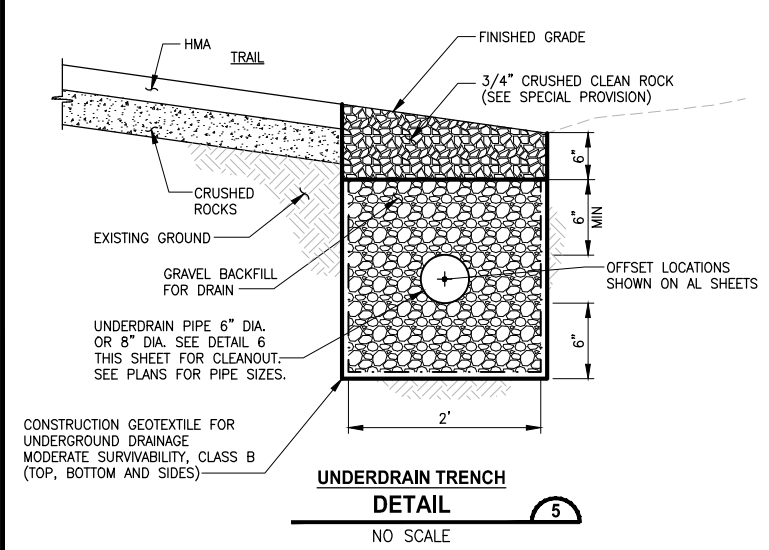
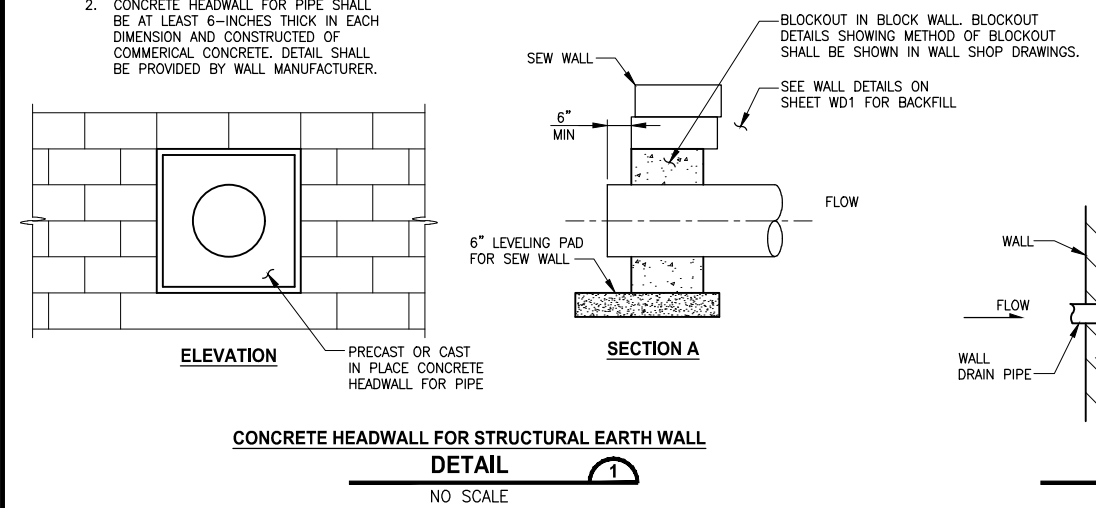
**STORM DRAINAGE PROFILES AND SECTIONS**

SHEET NO.  
 74 OF 135  
**SD3**

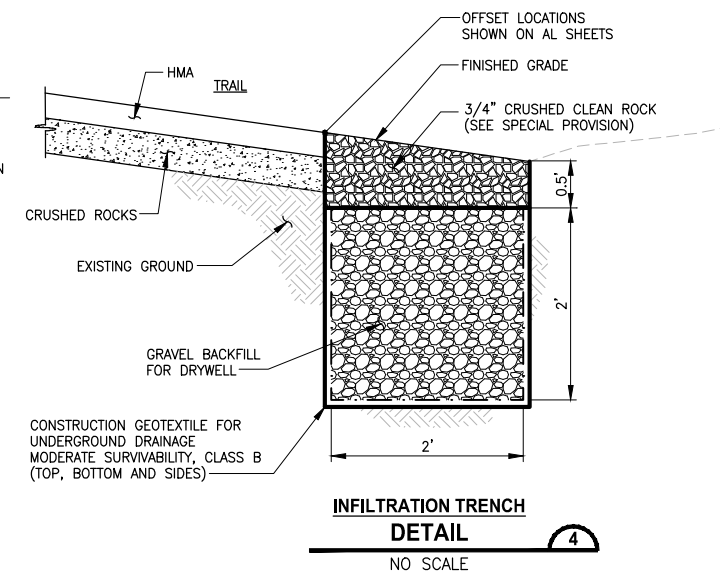


PATH: U:\P50\Projects\Clients\1521-KingCo\554-1521-075-ELST\985\CA00\Phase 19\T03 CIV\DWG\ PLOTTED BY: purgaban DATE: Wednesday, October 12, 2016 9:26:45 PM LAYOUT: DD1

**NOTES:**  
 1. FOR SEW WALLS SEE SHEET WD1.  
 2. CONCRETE HEADWALL FOR PIPE SHALL BE AT LEAST 6-INCHES THICK IN EACH DIMENSION AND CONSTRUCTED OF COMMERCIAL CONCRETE. DETAIL SHALL BE PROVIDED BY WALL MANUFACTURER.



**GENERAL NOTE:**  
 1. PROTECT INFILTRATION TRENCHES AND UNDERDRAIN TRENCHES FROM SEDIMENTATION DURING CONSTRUCTION.



CITY OF SAMMAMISH APPROVAL	
City Engineer _____	Date _____
Community Development _____	Date _____

**60% REVIEW SUBMITTAL**  
 NOT FOR CONSTRUCTION

REVISIONS	DATE	BY	DESIGNED
			C. BUITRAGO
			B. PURGANAN
			P. JOHANNESSEN
			Y. HO

ONE INCH AT FULL SCALE, IF NOT, SCALE ACCORDINGLY  
 FILE NAME: BL1521075P19T03DD-01  
 JOB No. 554-1521-075 P19 T03  
 DATE: SEPTEMBER 2016



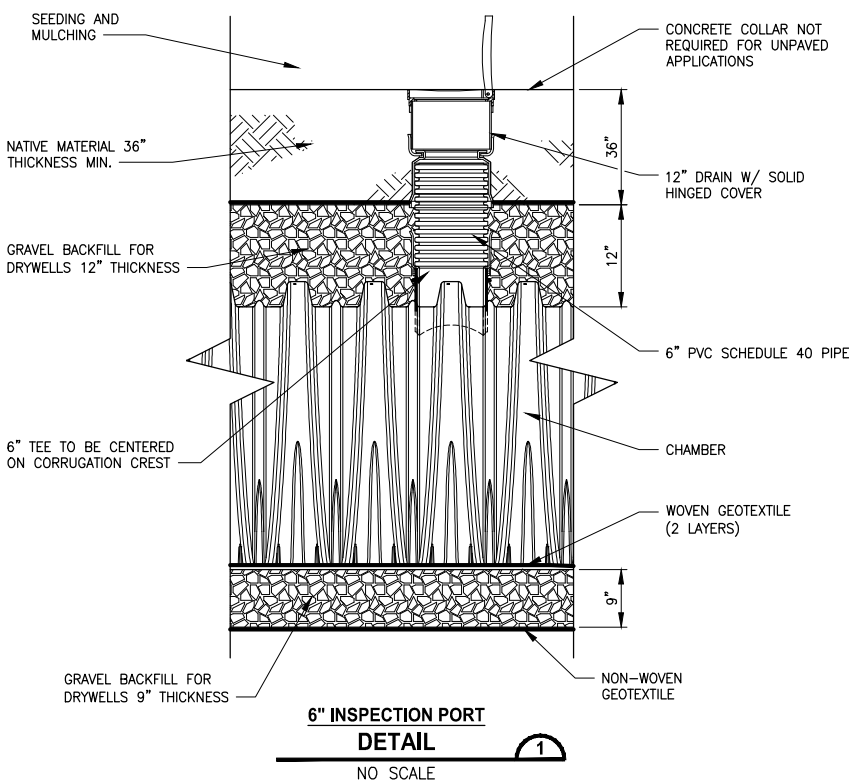
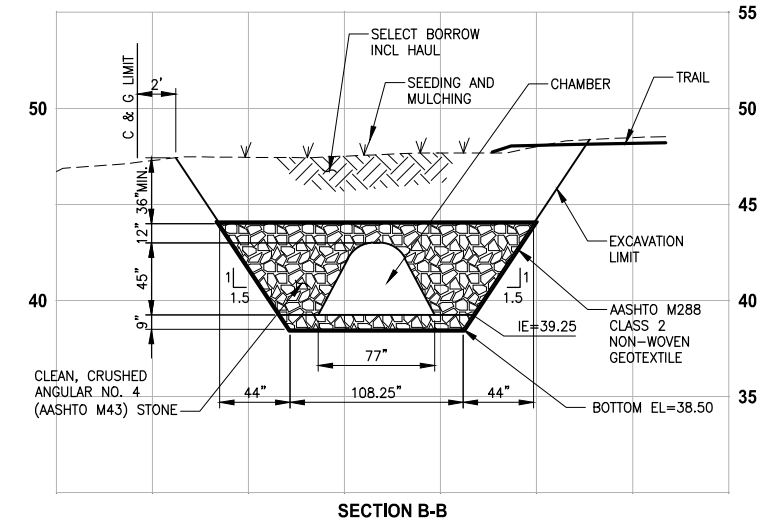
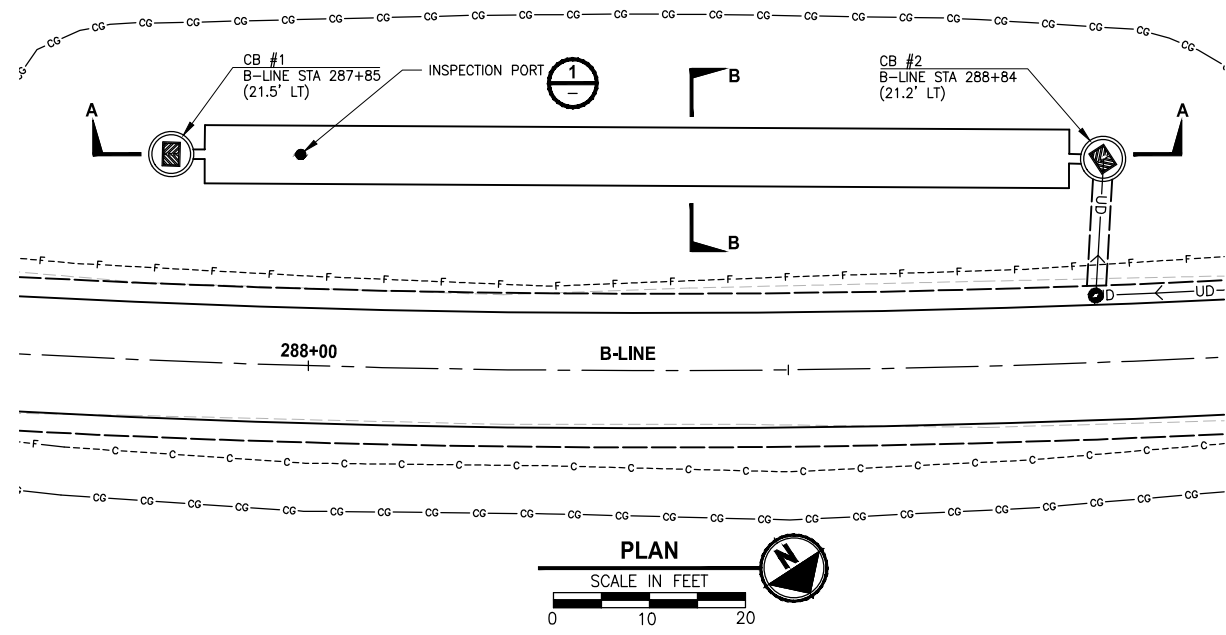
**Parametrix**  
 ENGINEERING · PLANNING · ENVIRONMENTAL SCIENCES  
 719 2ND AVENUE, SUITE 200 | SEATTLE, WA 98104  
 P 206.394.3700  
 WWW.PARAMETRIX.COM

PROJECT NAME  
**EAST LAKE SAMMAMISH MASTER PLAN TRAIL SOUTH SAMMAMISH SEGMENT B**  
 SAMMAMISH, WA

**DRAINAGE DETAILS**

SHEET NO. 75 OF 135  
**DD1**

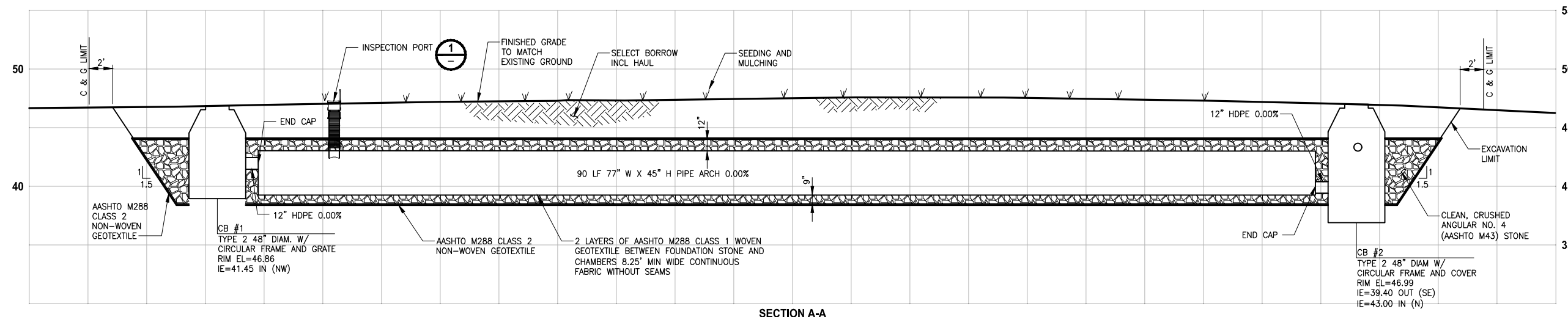
LAYOUT: DD2  
 PATH: U:\PSO\Projects\Clients\1521-KingCo\554-1521-075-ELST\99\Drawings\Phase 19\T03\_Civil\Draw\...  
 PLOTTED BY: purgaban DATE: Wednesday, October 12, 2016 9:27:06 PM



- STORMWATER CHAMBER SPECIFICATIONS:**
- CHAMBERS SHALL CONFORM TO REQUIREMENTS OF ASTM F2418 "STANDARD SPECIFICATION FOR POLYPROPYLENE (PP) CORRUGATED WALL STORMWATER COLLECTION CHAMBERS."
  - CHAMBERS SHALL BE DESIGNED IN ACCORDANCE WITH ASTM F2787 "STANDARD PRACTICE FOR STRUCTURAL DESIGN OF THERMOPLASTIC CORRUGATED WALL STORMWATER COLLECTION CHAMBERS."
  - CHAMBER SHALL PROVIDE CONTINUOUS, UNOBSTRUCTED INTERNAL SPACE WITH NO INTERNAL SUPPORT PANELS THAT WOULD IMPEDE FLOW OR LIMIT ACCESS FOR INSPECTION.
  - ONLY CHAMBERS THAT ARE APPROVED BY THE SITE DESIGN ENGINEER WILL BE ALLOWED. THE CHAMBER MANUFACTURER SHALL SUBMIT THE FOLLOWING UPON REQUEST TO THE SITE DESIGN ENGINEER FOR APPROVAL BEFORE DELIVERING CHAMBERS TO THE PROJECT SITE:
    - A STRUCTURAL EVALUATION SEALED BY A REGISTERED PROFESSIONAL ENGINEER THAT DEMONSTRATES THAT THE SAFETY FACTORS ARE GREATER THAN OR EQUAL TO 1.95 FOR DEAD LOAD AND 1.75 FOR LIVE LOAD, THE MINIMUM REQUIRED BY ASTM F2787 AND BY AASHTO FOR THERMOPLASTIC PIPE.
    - A STRUCTURAL EVALUATION SEALED BY A REGISTERED PROFESSIONAL ENGINEER THAT DEMONSTRATES THAT THE LOAD FACTORS SPECIFIED IN THE AASHTO LRFD BRIDGE DESIGN SPECIFICATIONS, SECTION 12.12, ARE MET. THE 50 YEAR CREEP MODULUS DATA SPECIFIED IN ASTM F2418 MUST BE USED AS PART OF THE AASHTO STRUCTURAL EVALUATION TO VERIFY LONG-TERM PERFORMANCE.
    - STRUCTURAL CROSS SECTION DETAIL ON WHICH THE STRUCTURAL EVALUATION IS BASED.
  - CHAMBERS AND END CAPS SHALL BE PRODUCED AT AN ISO 9001 CERTIFIED MANUFACTURING FACILITY.

- NOTES FOR CONSTRUCTION EQUIPMENT:**
- CHAMBERS SHALL BE INSTALLED IN ACCORDANCE WITH THE MANUFACTURER'S CONSTRUCTION GUIDE.
  - THE USE OF EQUIPMENT OVER CHAMBERS IS LIMITED:
    - NO EQUIPMENT IS ALLOWED ON BARE CHAMBERS.
    - NO RUBBER Tired LOADER, DUMP TRUCK, OR EXCAVATORS ARE ALLOWED UNTIL PROPER FILL DEPTHS ARE REACHED IN ACCORDANCE WITH THE MANUFACTURER'S CONSTRUCTION GUIDE.
    - WEIGHT LIMITS FOR CONSTRUCTION EQUIPMENT CAN BE FOUND IN THE MANUFACTURER'S CONSTRUCTION GUIDE.
  - FULL 36" (900 mm) OF STABILIZED COVER MATERIALS OVER THE CHAMBERS IS REQUIRED FOR DUMP TRUCK TRAVEL OR DUMPING.
  - USE OF A DOZER TO PUSH EMBEDMENT STONE AROUND THE CHAMBERS MAY CAUSE DAMAGE TO CHAMBERS AND IS NOT AN ACCEPTABLE BACKFILL METHOD. ANY CHAMBERS DAMAGED BY USING A "DUMP AND PUSH" METHOD MUST BE REPLACED AT THE FULL RESPONSIBILITY OF THE CONTRACTOR.

- BACKFILL AND COMPACTION NOTES:**
- FOR 9" CLEAN, CRUSHED, ANGULAR STONE BELOW CHAMBERS, PLATE COMPACT OR ROLL TO ACHIEVE 95% STANDARD PROCTOR DENSITY.
  - NO COMPACTION REQUIRED FOR GRAVEL BACKFILL FOR DRYWELLS PLACED AROUND AND 12-INCH DEPTH OVER CHAMBERS.
  - GRAVEL BACKFILL FOR DRYWELLS PLACED AROUND AND 12-INCH DEPTH OVER CHAMBERS MUST ALWAYS BE BROUGHT UP EVENLY WITH BACKFILL OF BED. MATERIAL MUST EXTEND HORIZONTALLY TO THE EXCAVATION WALL FOR EITHER STRAIGHT OR SLOPED EXCAVATED SIDEWALLS.
  - BEGIN COMPACTIONS AFTER 24" OF MATERIAL OVER THE CHAMBERS IS REACHED. COMPACT ADDITIONAL LAYERS IN 12" MAX LIFTS TO A MIN 95% PROCTOR DENSITY FOR WELL GRADED MATERIAL AND 95% RELATIVE DENSITY FOR PROCESSED AGGREGATE MATERIALS.

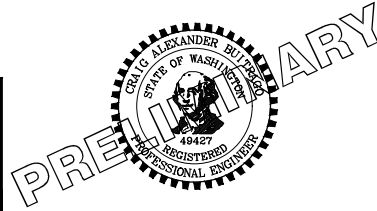


CITY OF SAMMAMISH APPROVAL	
City Engineer _____	Date _____
Community Development _____	Date _____

**60% REVIEW SUBMITTAL**  
NOT FOR CONSTRUCTION

REVISIONS	DATE	BY	DESIGNED
			C. BUITRAGO
			B. PURGANAN
			P. JOHANNESSEN
			Y. HO

ONE INCH AT FULL SCALE, IF NOT, SCALE ACCORDINGLY  
 FILE NAME: BL1521075P19T03DD-01  
 JOB No. 554-1521-075 P19 T03  
 DATE: SEPTEMBER 2016



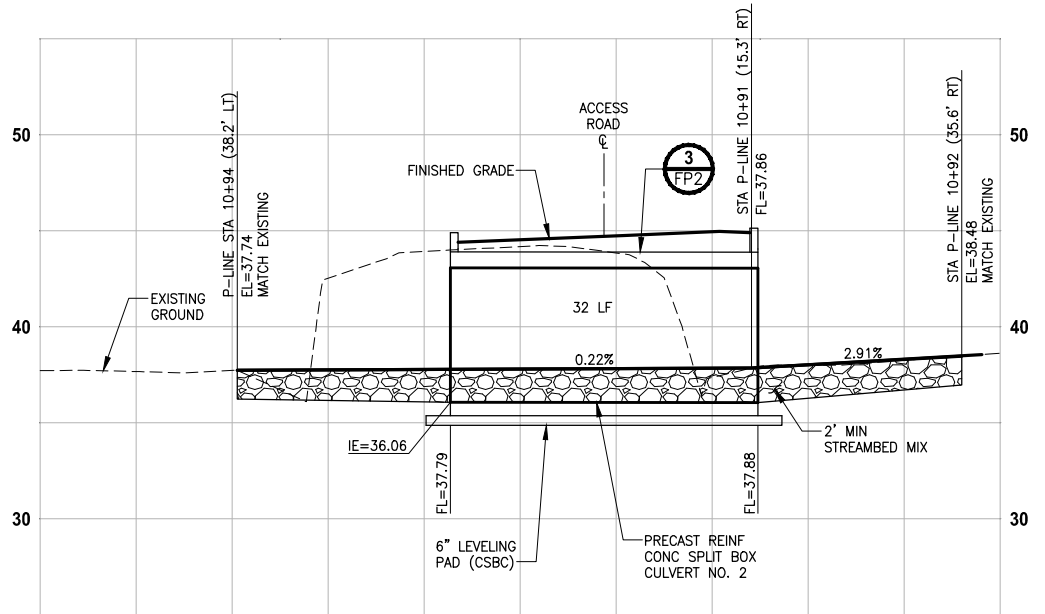
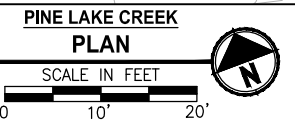
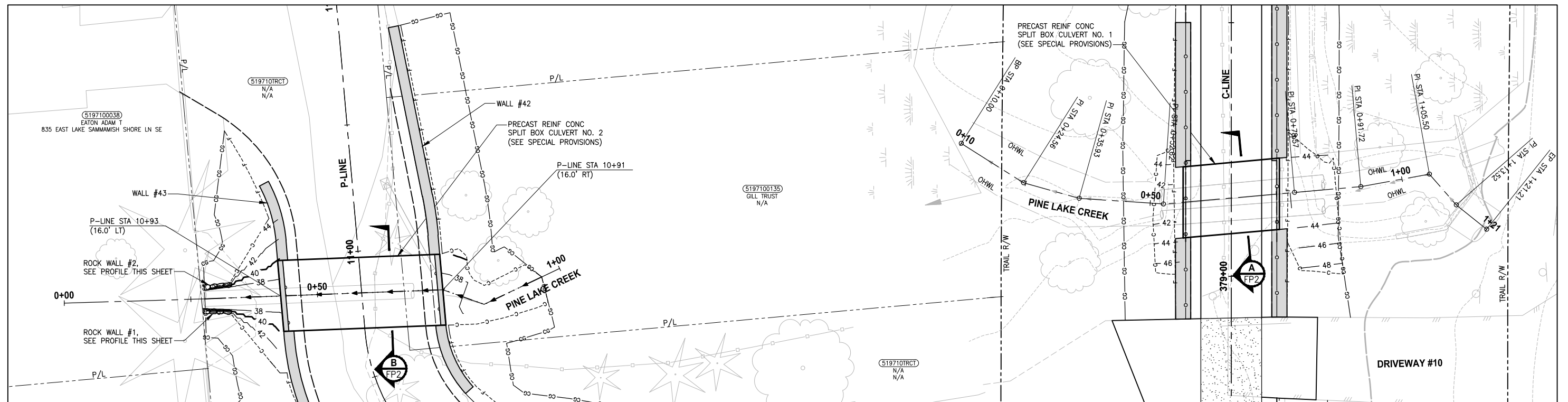
**Parametrix**  
 ENGINEERING · PLANNING · ENVIRONMENTAL SCIENCES  
 719 2ND AVENUE, SUITE 200 | SEATTLE, WA 98104  
 P 206.394.3700  
 WWW.PARAMETRIX.COM

PROJECT NAME  
**EAST LAKE SAMMAMISH MASTER PLAN TRAIL SOUTH SAMMAMISH SEGMENT B**  
 SAMMAMISH, WA

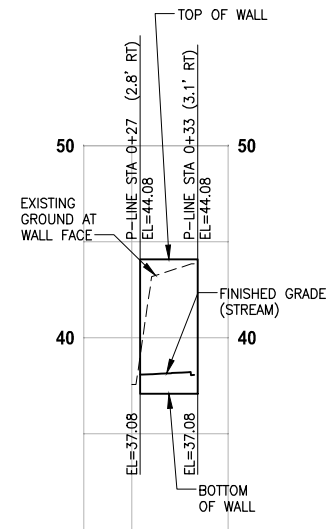
**DRAINAGE DETAILS**

SHEET NO.  
76 OF 135  
**DD2**

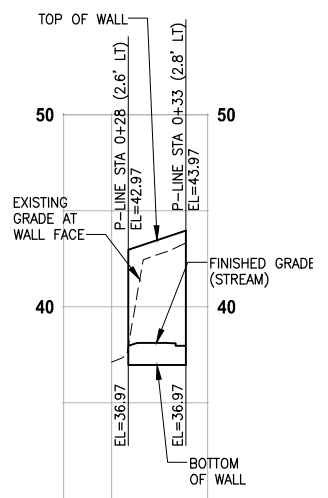
PATH: U:\PSO\Projects\Clients\1521-075-ELST\98\Drawings\19\103 CIV\DWG\ PLOTTED BY: purgaban DATE: Wednesday, October 12, 2016 9:30:21 PM LAYOUT: FP1



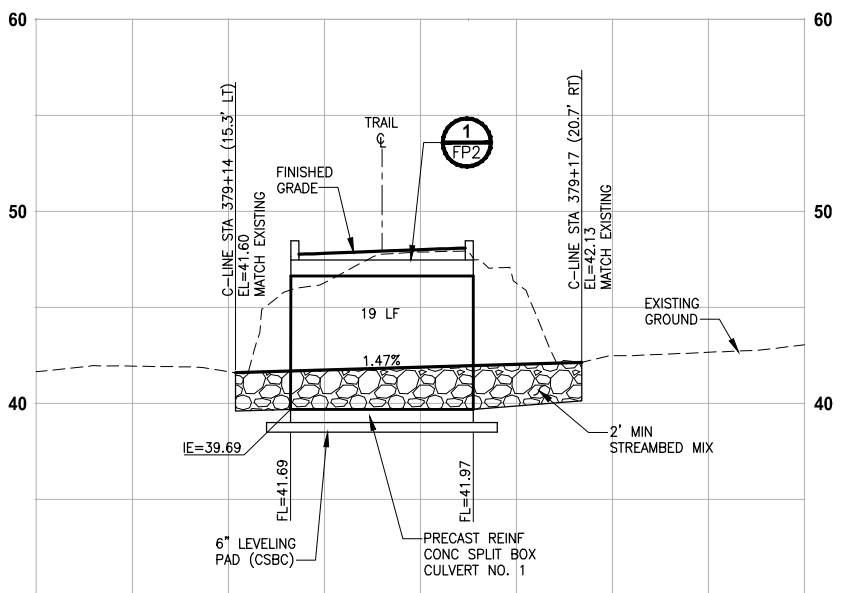
**PINE LAKE CREEK 2  
PROFILE P-LINE STA 0+61**  
HORIZ: 1"=10'  
VERT: 1"=5'



**ROCK WALL #1  
PROFILE**  
HORIZ: 1"=10'  
VERT: 1"=5'



**ROCK WALL #2  
PROFILE**  
HORIZ: 1"=10'  
VERT: 1"=5'



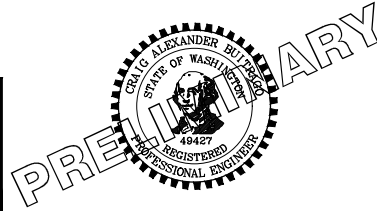
**PINE LAKE CREEK 1  
PROFILE C-LINE STA 379+15**  
HORIZ: 1"=10'  
VERT: 1"=5'

CITY OF SAMMAMISH APPROVAL	
City Engineer _____	Date _____
Community Development _____	Date _____

**60% REVIEW SUBMITTAL  
NOT FOR CONSTRUCTION**

REVISIONS	DATE	BY	DESIGNED
			C. BUITRAGO
			B. PURGANAN
			P. JOHANNESSEN
			Y. HO

ONE INCH AT FULL SCALE, IF NOT, SCALE ACCORDINGLY  
FILE NAME: BL1521075P19T03FP-01  
JOB No: 54-1521-075 P19 T03  
DATE: SEPTEMBER 2016



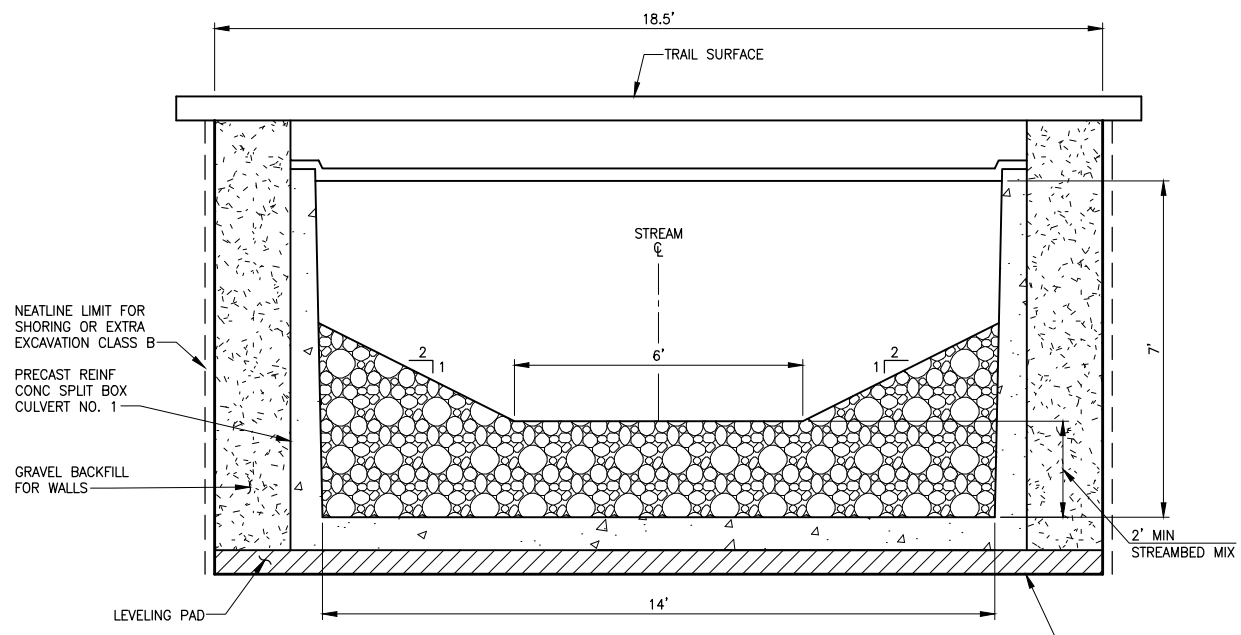
**Parametrix**  
ENGINEERING · PLANNING · ENVIRONMENTAL SCIENCES  
719 2ND AVENUE, SUITE 200 | SEATTLE, WA 98104  
P 206.394.3700  
WWW.PARAMETRIX.COM

PROJECT NAME  
**EAST LAKE SAMMAMISH  
MASTER PLAN TRAIL  
SOUTH SAMMAMISH SEGMENT B**  
SAMMAMISH, WA

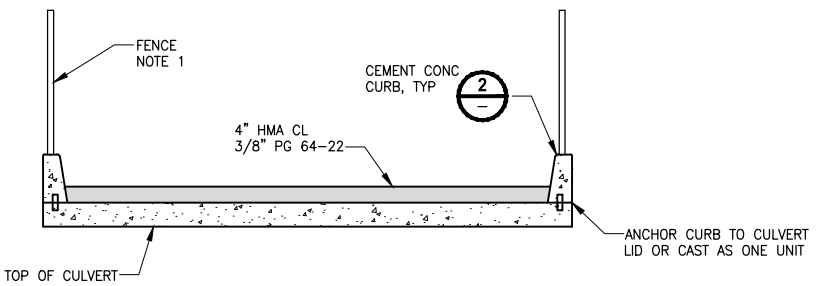
**FISH PASSAGE CULVERTS**

SHEET NO.  
77 OF 135  
**FP1**

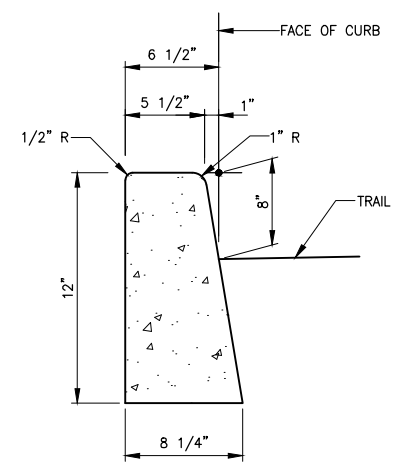
PATH: U:\P50\Projects\Clients\1521-KingCo\554-1521-075-ELST\98\Specs\CADD\Phase 19\T03\_Civil\DWG\ PLOTTED BY: purgabat DATE: Wednesday, October 12, 2016 9:30:45 PM LAYOUT: FP2



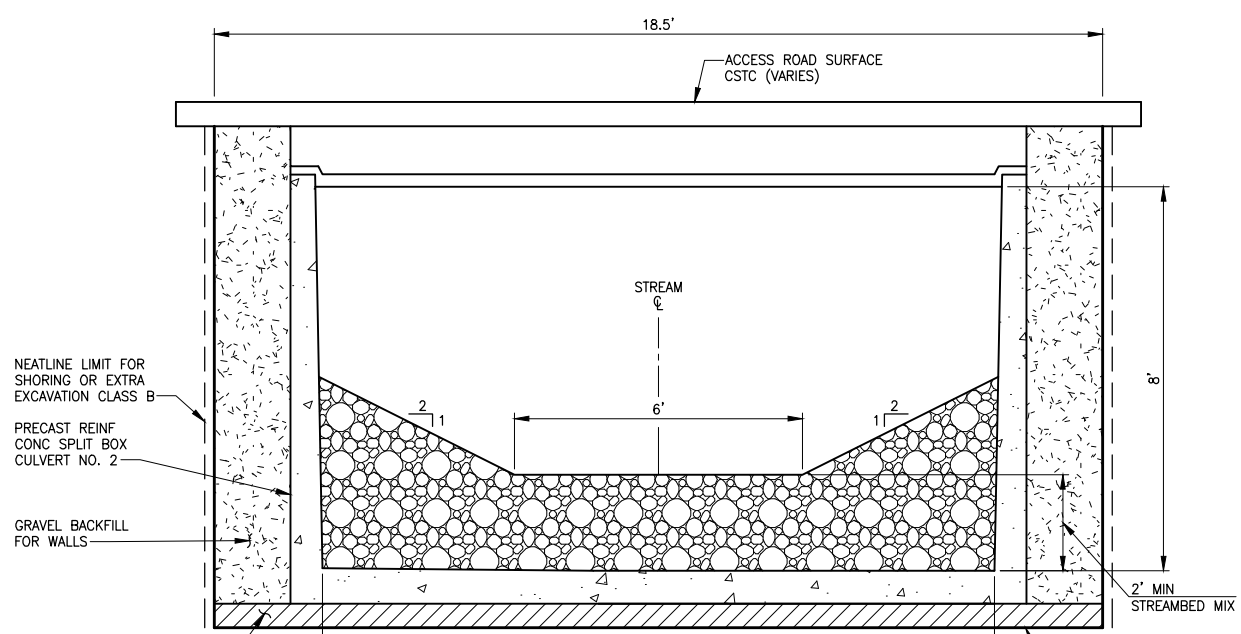
**PINE LAKE CREEK 1 (BOX CULVERT NO. 1)**  
**TYPICAL SECTION A**  
 NO SCALE



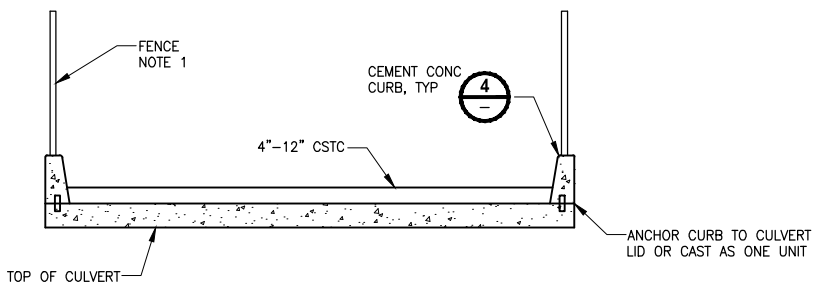
**CULVERT COVER DETAIL 1**  
 NO SCALE



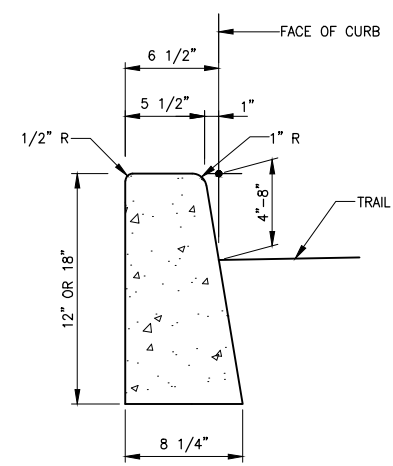
**CEMENT CONCRETE CURB DETAIL 2**  
 NO SCALE



**PINE LAKE CREEK 2 (BOX CULVERT NO. 2)**  
**TYPICAL SECTION B**  
 NO SCALE



**CULVERT COVER DETAIL 3**  
 NO SCALE



**CEMENT CONCRETE CURB DETAIL 4**  
 NO SCALE

- NOTES:**
- CONSTRUCTION ACTIVITY FOR CULVERTS SHALL NOT OCCUR UNTIL AFTER STRUCTURAL ENGINEERING APPROVAL IS OBTAINED.
  - BOX CULVERTS AND STREAM WORK BELOW ORDINARY HIGH WATER LINE SHALL ONLY OCCUR BETWEEN JUNE 16 AND SEPTEMBER 30 PER HPA APPROVAL CONDITIONS IN APPENDIX B OF THE SPECIAL PROVISIONS.

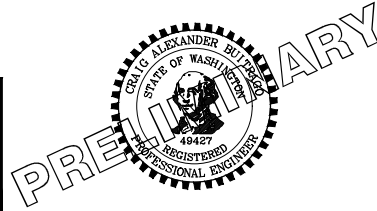
CITY OF SAMMAMISH APPROVAL	
City Engineer _____	Date _____
Community Development _____	Date _____

**60% REVIEW SUBMITTAL**  
 NOT FOR CONSTRUCTION

REVISIONS	DATE	BY	DESIGNED
			C. BUIRAGO
			B. PURGANAN
			P. JOHANNESSEN
			Y. HO

**ONE INCH AT FULL SCALE, IF NOT, SCALE ACCORDINGLY**

FILE NAME: BL1521075P19T03FP-01  
 JOB No.: 554-1521-075 P19 T03  
 DATE: SEPTEMBER 2016



**Parametrix**  
 ENGINEERING · PLANNING · ENVIRONMENTAL SCIENCES

719 2ND AVENUE, SUITE 200 | SEATTLE, WA 98104  
 P 206.394.3700  
 WWW.PARAMETRIX.COM

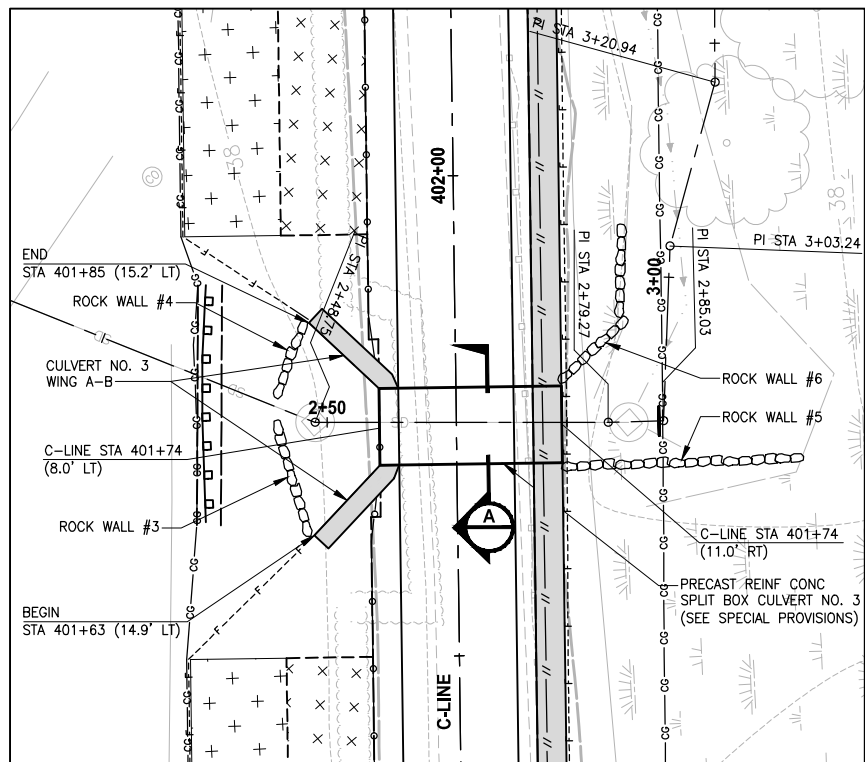
PROJECT NAME  
**EAST LAKE SAMMAMISH MASTER PLAN TRAIL SOUTH SAMMAMISH SEGMENT B**  
 SAMMAMISH, WA

**FISH PASSAGE CULVERTS**

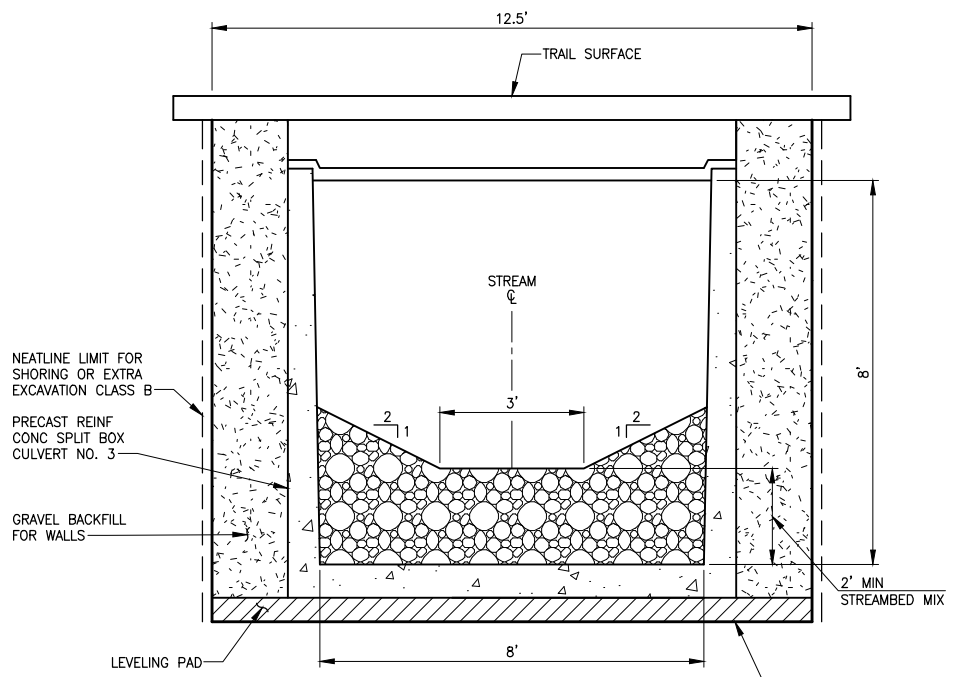
SHEET NO.  
 78 OF 135  
**FP2**



PATH: U:\P50\Projects\Clients\1521-075-ELST\99\Specs\CADD\Phase 19\T03\_Civil\Drawg\ PLOTTED BY: purganub DATE: Wednesday, October 12, 2016 9:31:25 PM LAYOUT: FP3

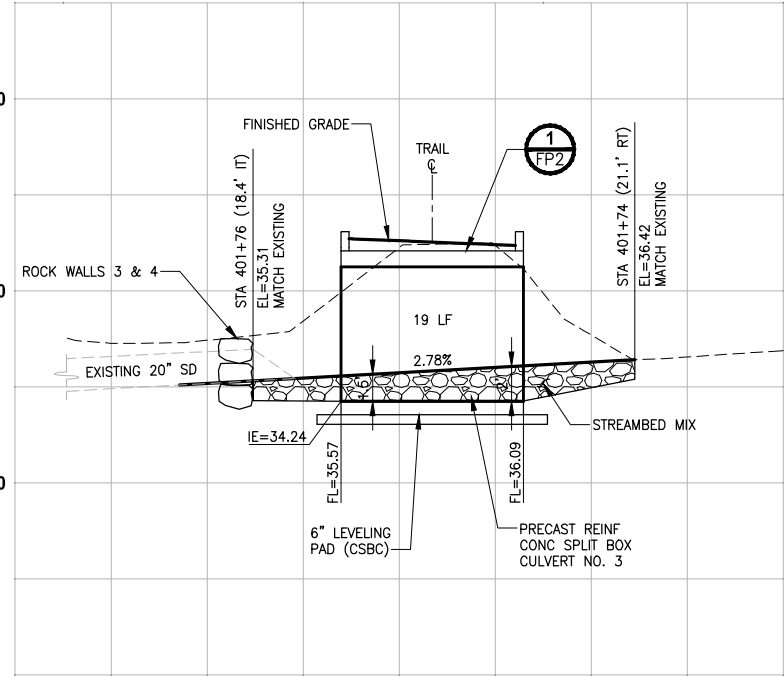


**STREAM #0155**  
**PLAN**  
 SCALE IN FEET  
 0 10' 20'

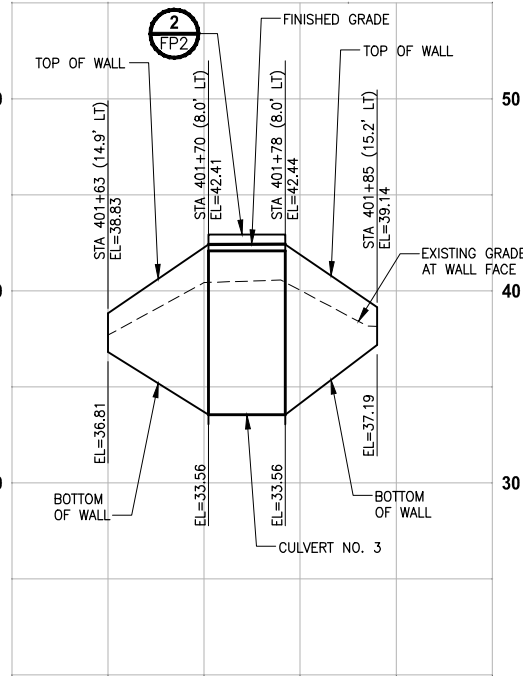


**STREAM #0155 (BOX CULVERT NO. 3)**  
**TYPICAL SECTION A**  
 NO SCALE

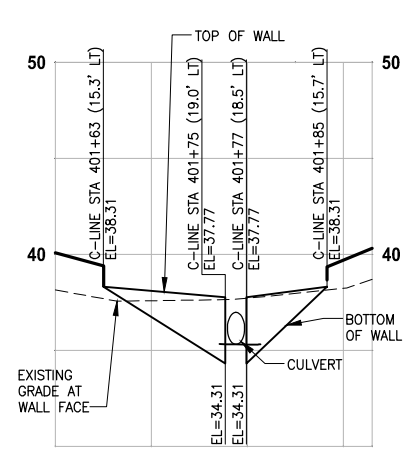
- NOTES:**
- CONSTRUCTION ACTIVITY FOR CULVERTS SHALL NOT OCCUR UNTIL AFTER STRUCTURAL ENGINEERING APPROVAL IS OBTAINED.
  - BOX CULVERTS AND STREAM WORK BELOW ORDINARY HIGH WATER LINE SHALL ONLY OCCUR BETWEEN JUNE 16 AND SEPTEMBER 30 PER HPA APPROVAL CONDITIONS IN APPENDIX B OF THE SPECIAL PROVISIONS.



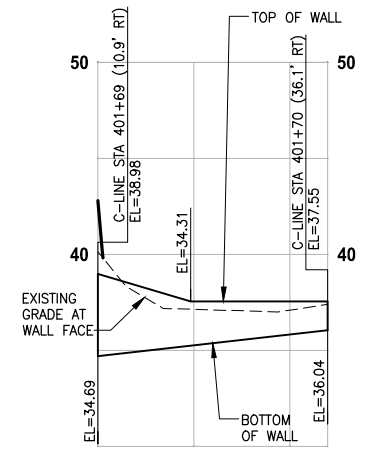
**STREAM #0155**  
**PROFILE B-LINE STA 401+75**  
 HORIZ: 1"=10'  
 VERT: 1"=5'



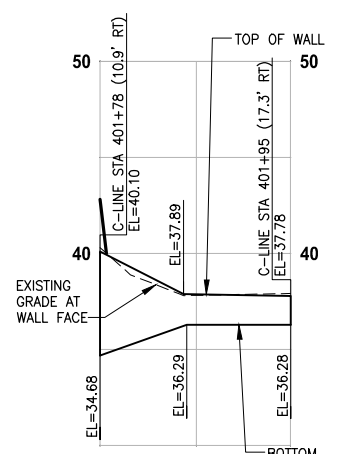
**STREAM #0155**  
**PROFILE CULVERT 3 WING AB**  
 HORIZ: 1"=10'  
 VERT: 1"=5'



**ROCK WALLS #3 & #4**  
**PROFILE**  
 HORIZ: 1"=10'  
 VERT: 1"=5'



**ROCK WALL #5**  
**PROFILE**  
 HORIZ: 1"=10'  
 VERT: 1"=5'



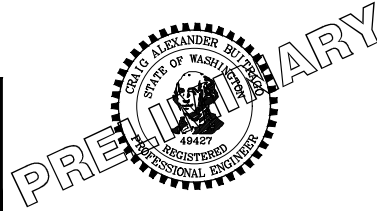
**ROCK WALL #6**  
**PROFILE**  
 HORIZ: 1"=10'  
 VERT: 1"=5'

CITY OF SAMMAMISH APPROVAL	
City Engineer _____	Date _____
Community Development _____	Date _____

**60% REVIEW SUBMITTAL**  
 NOT FOR CONSTRUCTION

REVISIONS	DATE	BY	DESIGNED
			C. BUITRAGO
			B. PURGANAN
			P. JOHANNESSEN
			Y. HO

ONE INCH AT FULL SCALE, IF NOT, SCALE ACCORDINGLY  
 FILE NAME: BL1521075P19T03FP-01  
 JOB No: 554-1521-075 P19 T03  
 DATE: SEPTEMBER 2016



**Parametrix**  
 ENGINEERING · PLANNING · ENVIRONMENTAL SCIENCES  
 719 2ND AVENUE, SUITE 200 | SEATTLE, WA 98104  
 P 206.394.3700  
 WWW.PARAMETRIX.COM

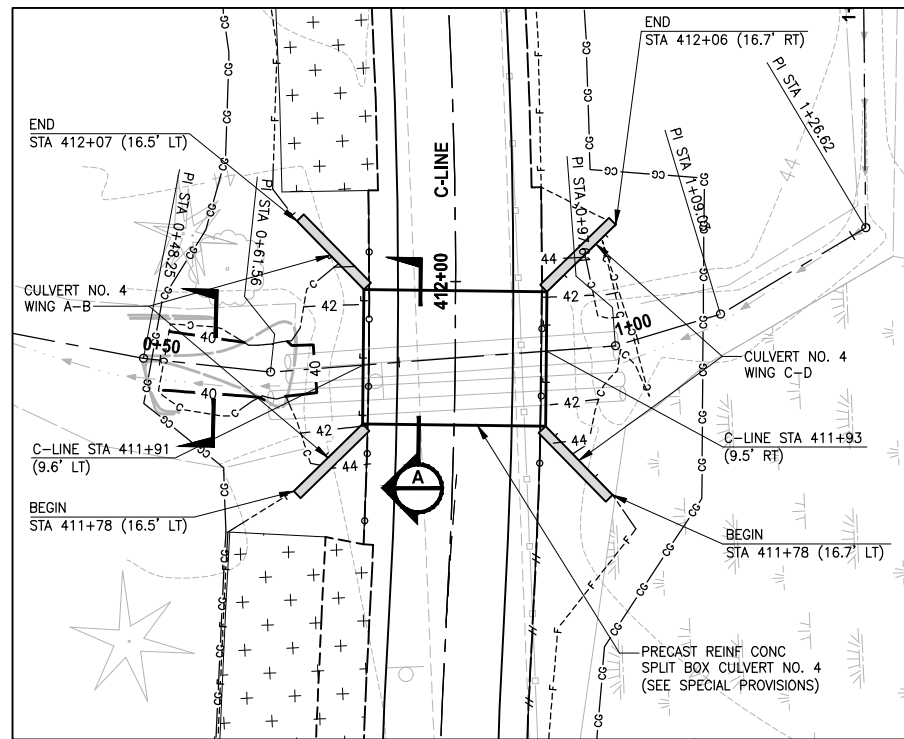
PROJECT NAME  
**EAST LAKE SAMMAMISH**  
**MASTER PLAN TRAIL**  
**SOUTH SAMMAMISH SEGMENT B**  
 SAMMAMISH, WA

**FISH PASSAGE CULVERTS**

SHEET NO.  
 79 OF 135  
**FP3**



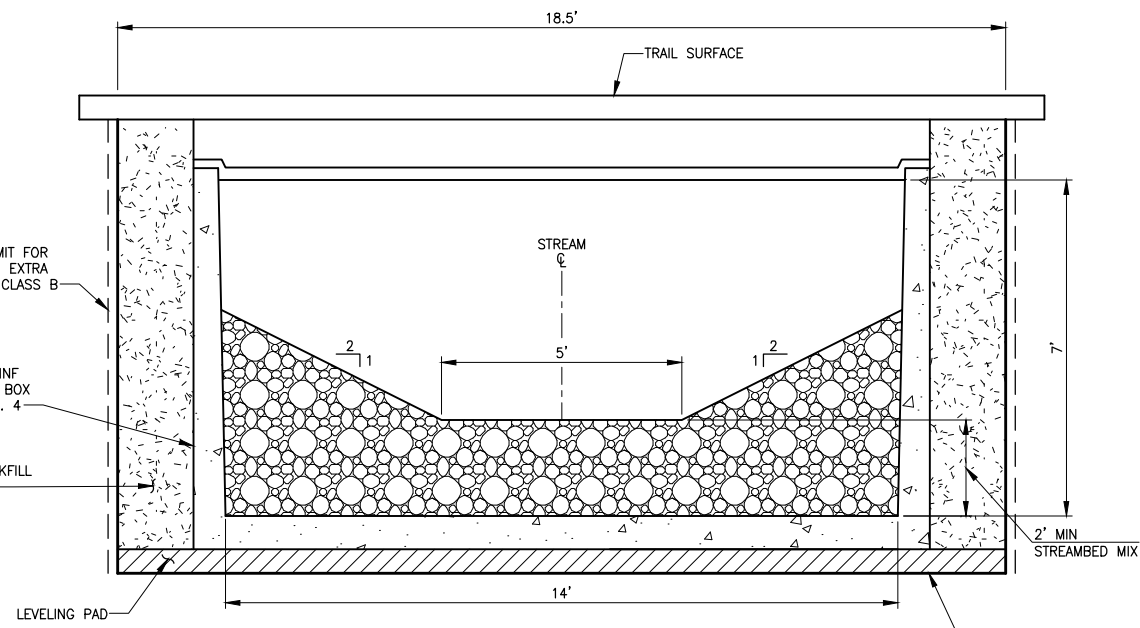
PATH: U:\P50\Projects\Clients\1521-075-ELST\99Secs\CADD\Phase 19\103\_Civil\Draw\ PLOTTED BY: purgabat DATE: Wednesday, October 12, 2016 9:31:56 PM LAYOUT: FP4



**EBRIGHT CREEK (BOX CULVERT NO. 4)**

**PLAN**

SCALE IN FEET  
0 10' 20'



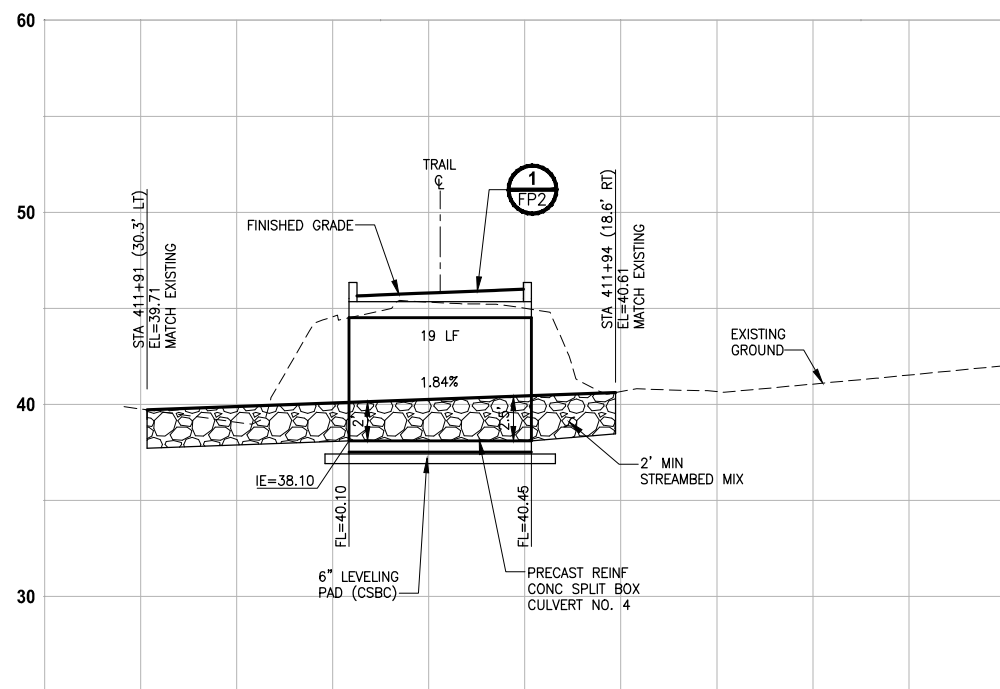
**EBRIGHT CREEK (BOX CULVERT NO. 4)**

**TYPICAL SECTION**

NO SCALE

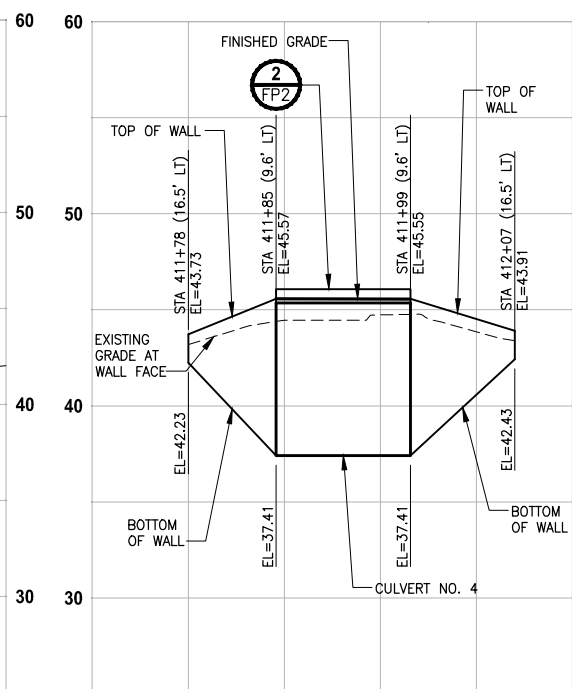
**NOTES:**

- CONSTRUCTION ACTIVITY FOR CULVERTS SHALL NOT OCCUR UNTIL AFTER STRUCTURAL ENGINEERING APPROVAL IS OBTAINED.
- BOX CULVERTS AND STREAM WORK BELOW ORDINARY HIGH WATER LINE SHALL ONLY OCCUR BETWEEN JUNE 15 AND SEPTEMBER 30 PER HPA APPROVAL CONDITIONS IN APPENDIX B OF THE SPECIAL PROVISIONS.



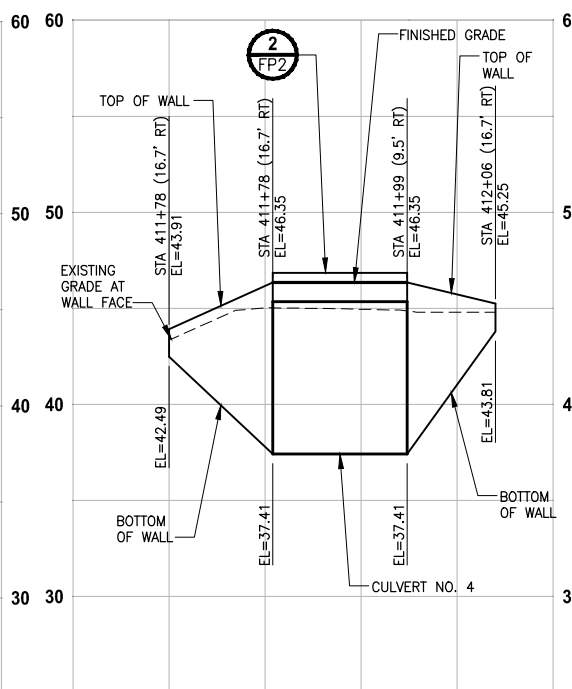
**EBRIGHT CREEK  
PROFILE C-LINE STA 411+90**

HORIZ: 1"=10'  
VERT: 1"=5'



**EBRIGHT CREEK  
PROFILE CULVERT 4 WING AB**

HORIZ: 1"=10'  
VERT: 1"=5'



**EBRIGHT CREEK  
PROFILE CULVERT 4 WING CD**

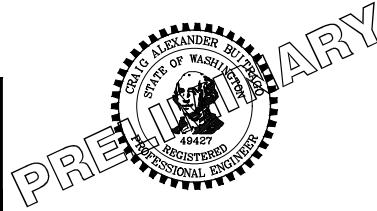
HORIZ: 1"=10'  
VERT: 1"=5'

CITY OF SAMMAMISH APPROVAL	
City Engineer _____	Date _____
Community Development _____	Date _____

**60% REVIEW SUBMITTAL  
NOT FOR CONSTRUCTION**

REVISIONS	DATE	BY	DESIGNED
			C. BUITRAGO
			B. PURGANAN
			P. JOHANNESSEN
			Y. HO

**ONE INCH AT FULL SCALE,  
IF NOT, SCALE ACCORDINGLY**  
 FILE NAME  
 BL1521075P19T03FP-01  
 JOB No.  
 54-1521-075 P19 T03  
 DATE  
 SEPTEMBER 2016



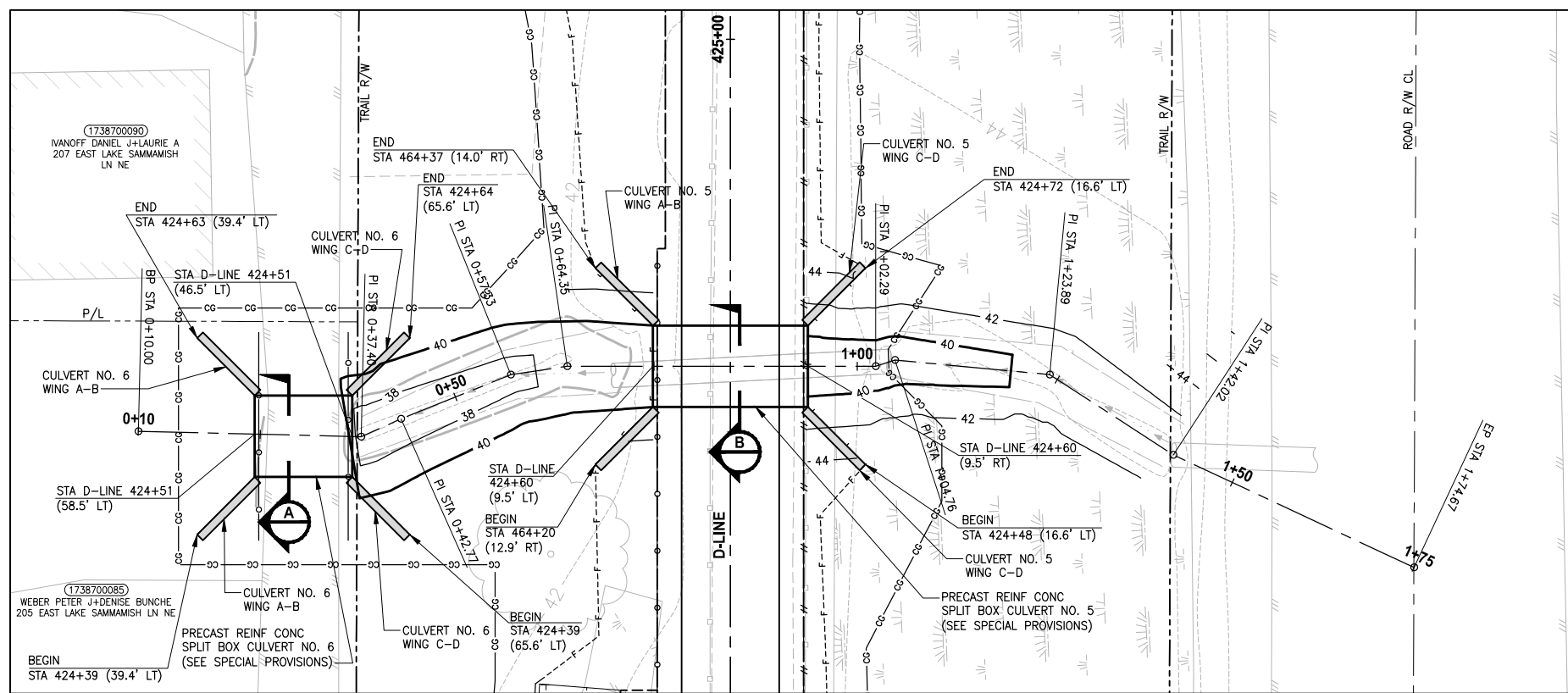
**Parametrix**  
 ENGINEERING · PLANNING · ENVIRONMENTAL SCIENCES  
 719 2ND AVENUE, SUITE 200 | SEATTLE, WA 98104  
 P 206.394.3700  
 WWW.PARAMETRIX.COM

PROJECT NAME  
**EAST LAKE SAMMAMISH  
MASTER PLAN TRAIL  
SOUTH SAMMAMISH SEGMENT B**  
 SAMMAMISH, WA

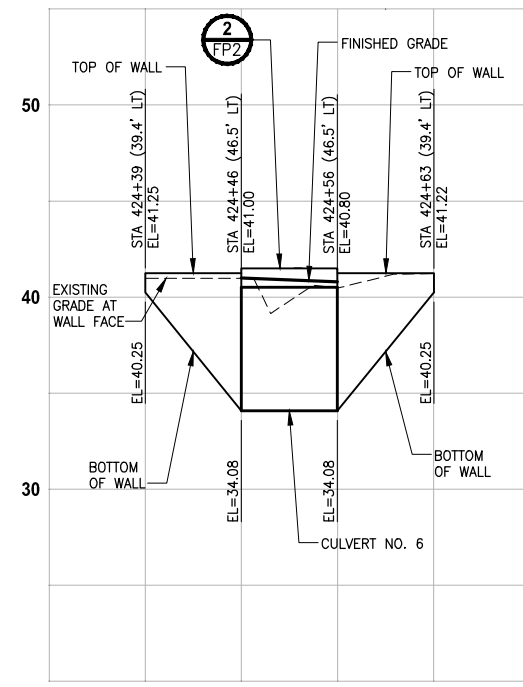
**FISH PASSAGE CULVERTS**

SHEET NO.  
 80 OF 135  
**FP4**

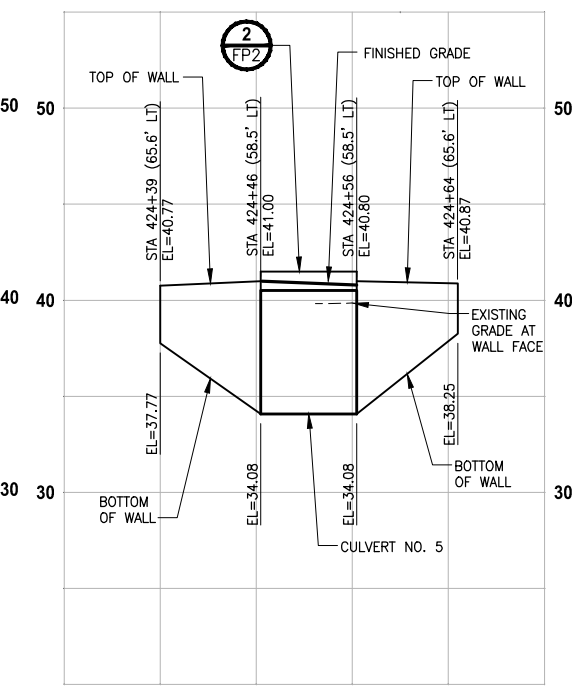
LAYOUT: FP5  
 PATH: U:\P50\Projects\Clients\1521-KingCo\554-1521-075-ELST\99\Drawings\Phase 19\T03\_Civil\Drawings\1738700090\1738700090.dwg  
 PLOTTED BY: purgabat DATE: Wednesday, October 12, 2016 9:32:28 PM



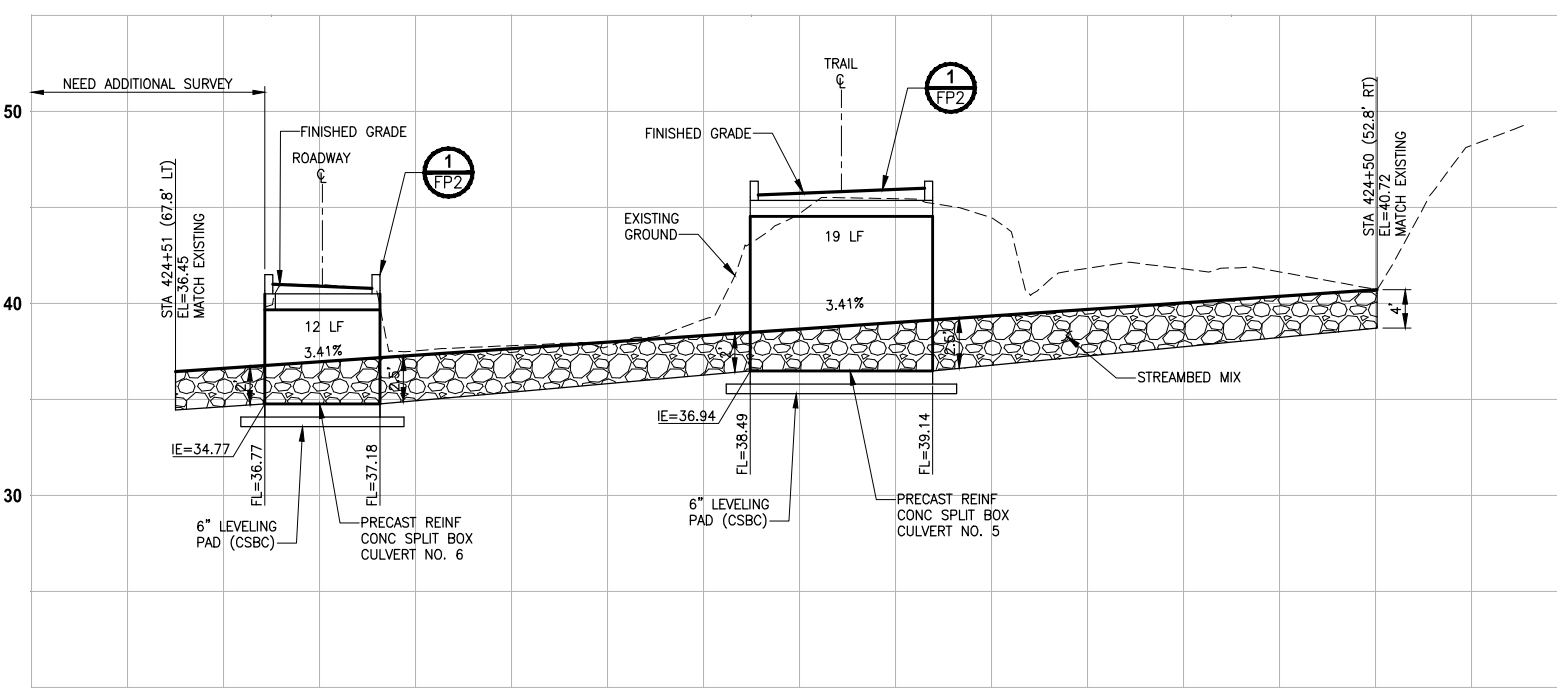
**ZACCUSE CREEK**  
**PLAN**  
 SCALE IN FEET  
 0 10' 20'



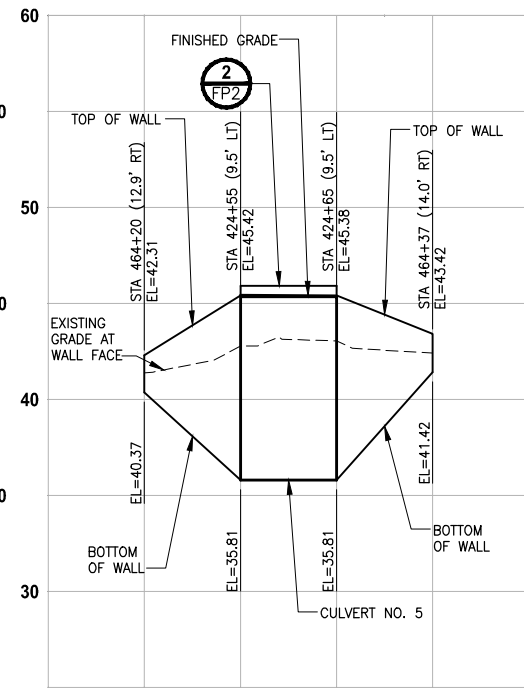
**ZACCUSE CREEK**  
**PROFILE CULVERT 6 WING AB**  
 HORIZ: 1"=10'  
 VERT: 1"=5'



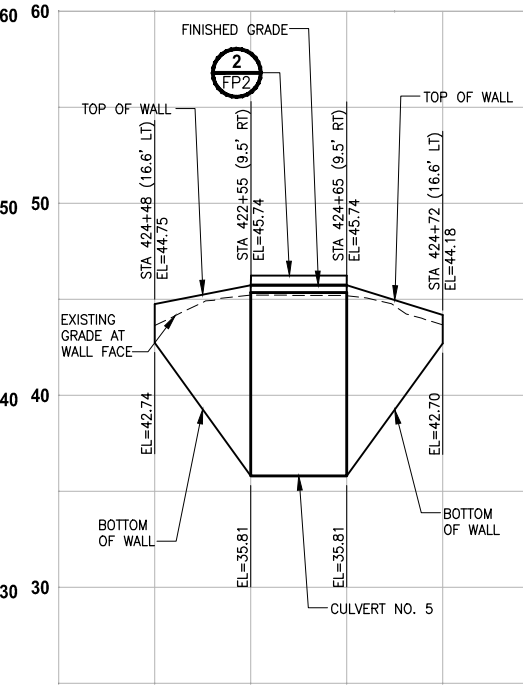
**ZACCUSE CREEK**  
**PROFILE CULVERT 6 WING CD**  
 HORIZ: 1"=10'  
 VERT: 1"=5'



**ZACCUSE CREEK**  
**PROFILE D-LINE STA 424+60**  
 HORIZ: 1"=10'  
 VERT: 1"=5'



**ZACCUSE CREEK**  
**PROFILE CULVERT 5 WING AB**  
 HORIZ: 1"=10'  
 VERT: 1"=5'



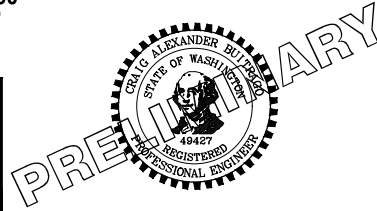
**ZACCUSE CREEK**  
**PROFILE CULVERT 5 WING CD**  
 HORIZ: 1"=10'  
 VERT: 1"=5'

CITY OF SAMMAMISH APPROVAL	
City Engineer _____	Date _____
Community Development _____	Date _____

**60 % REVIEW SUBMITTAL**  
**NOT FOR CONSTRUCTION**

REVISIONS	DATE	BY	DESIGNED
			C. BUITRAGO
			B. PURGANAN
			P. JOHANNESSEN
			Y. HO

ONE INCH AT FULL SCALE,  
 IF NOT, SCALE ACCORDINGLY  
 FILE NAME: BL1521075P19T03FP-01  
 JOB No.: 554-1521-075 P19 T03  
 DATE: SEPTEMBER 2016



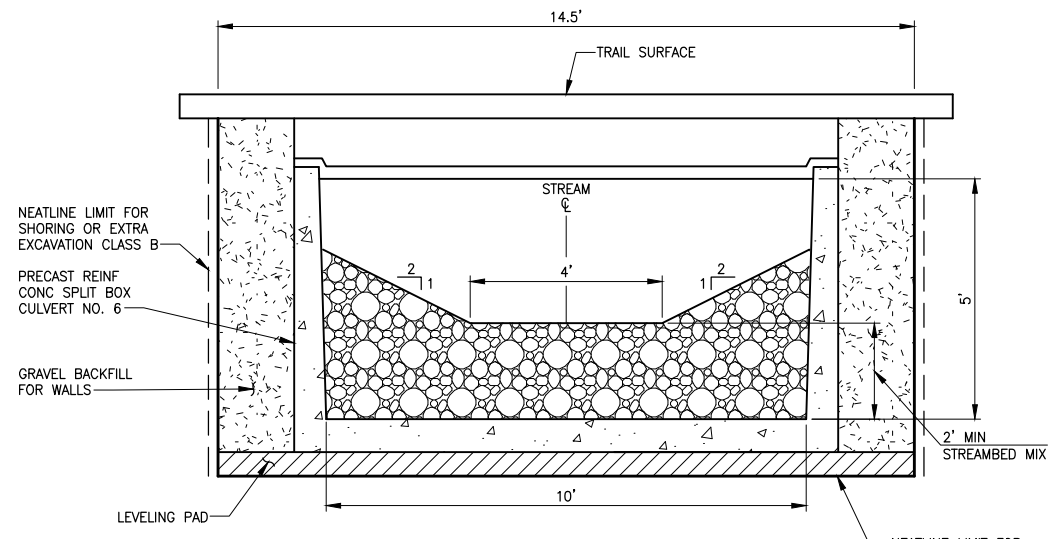
**Parametrix**  
 ENGINEERING · PLANNING · ENVIRONMENTAL SCIENCES  
 719 2ND AVENUE, SUITE 200 | SEATTLE, WA 98104  
 P 206.394.3700  
 WWW.PARAMETRIX.COM

PROJECT NAME  
**EAST LAKE SAMMAMISH**  
**MASTER PLAN TRAIL**  
**SOUTH SAMMAMISH SEGMENT B**  
 SAMMAMISH, WA

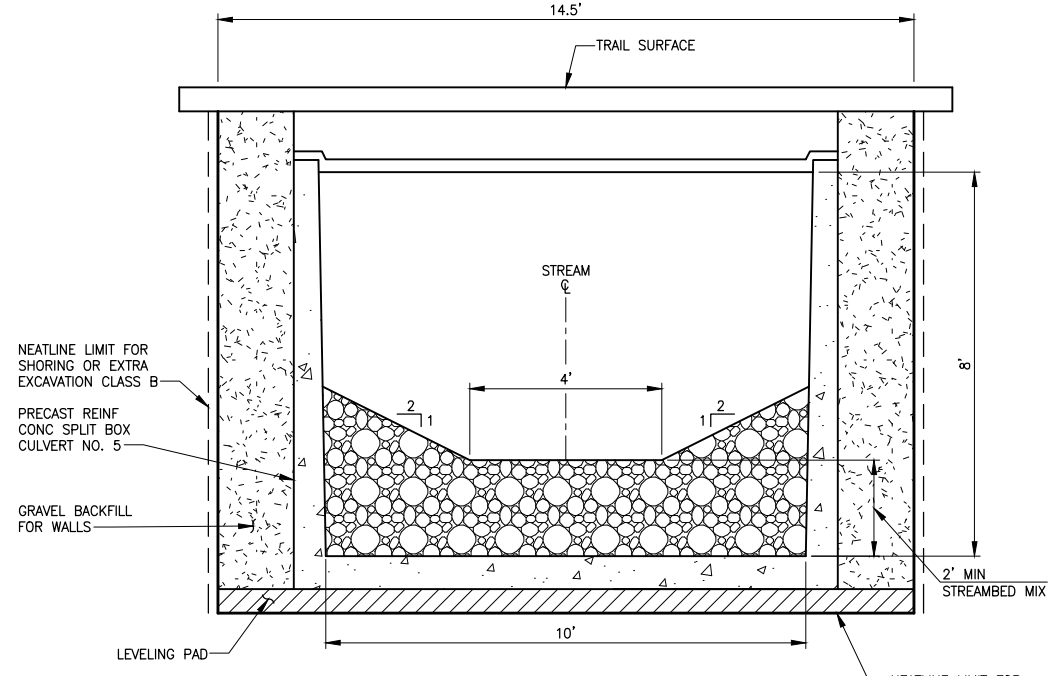
**FISH PASSAGE CULVERTS**

SHEET NO.  
 81 OF 135  
**FP5**

PATH: U:\P50\Projects\Clients\1521-KingCo\554-1521-075-ELST\99Sves\CADD\Phase 19\T03-Civil\DWG\ LAYOUT: FP6  
 PLOTTED BY: purgubut DATE: Wednesday, October 12, 2016 9:32:50 PM



**ZACCUSE CREEK 2 (BOX CULVERT NO. 6)**  
**TYPICAL SECTION A**  
 NO SCALE



**ZACCUSE CREEK 1 (BOX CULVERT NO. 5)**  
**TYPICAL SECTION B**  
 NO SCALE

**NOTES:**

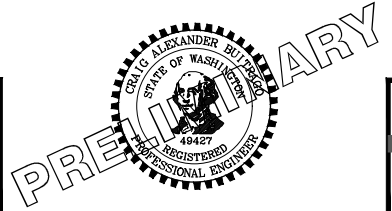
- CONSTRUCTION ACTIVITY FOR CULVERTS SHALL NOT OCCUR UNTIL AFTER STRUCTURAL ENGINEERING APPROVAL IS OBTAINED.
- BOX CULVERTS AND STREAM WORK BELOW ORDINARY HIGH WATER LINE SHALL ONLY OCCUR BETWEEN JUNE 16 AND SEPTEMBER 30 PER HPA APPROVAL CONDITIONS IN APPENDIX B OF THE SPECIAL PROVISIONS.

CITY OF SAMMAMISH APPROVAL	
City Engineer _____	Date _____
Community Development _____	Date _____

**60 % REVIEW SUBMITTAL**  
 NOT FOR CONSTRUCTION

REVISIONS	DATE	BY	DESIGNED
			C. BUITRAGO
			B. PURGANAN
			P. JOHANNESSEN
			Y. HO

**ONE INCH AT FULL SCALE.**  
**IF NOT, SCALE ACCORDINGLY**  
 FILE NAME: BL1521075P19T03FP-01  
 JOB No: 554-1521-075 P19 T03  
 DATE: SEPTEMBER 2016



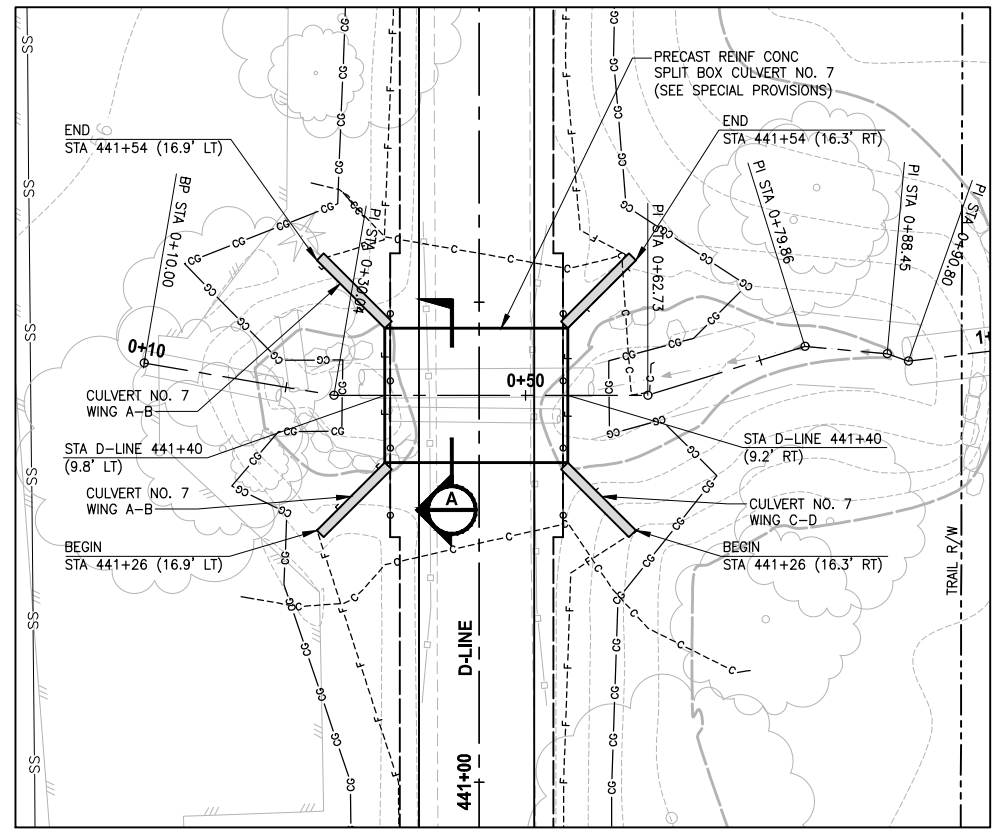
**Parametrix**  
 ENGINEERING · PLANNING · ENVIRONMENTAL SCIENCES  
 719 2ND AVENUE, SUITE 200 | SEATTLE, WA 98104  
 P 206.394.3700  
 WWW.PARAMETRIX.COM

PROJECT NAME  
**EAST LAKE SAMMAMISH**  
**MASTER PLAN TRAIL**  
**SOUTH SAMMAMISH SEGMENT B**  
 SAMMAMISH, WA

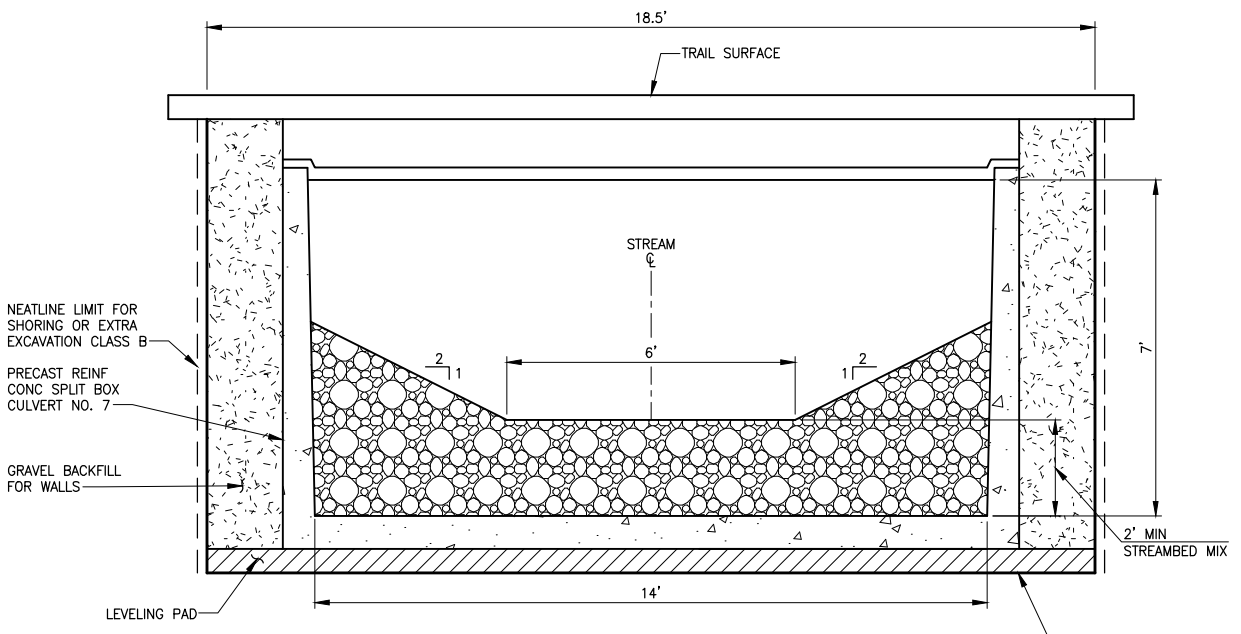
**FISH PASSAGE CULVERTS**

SHEET NO.  
 82 OF 135  
**FP6**

PATH: U:\P50\Projects\Clients\1521-KingCo\554-1521-075-ELST\99Specs\CADD\Phase 19\T03\_Civil\Draw\ PLOTTED BY: purgabat DATE: Wednesday, October 12, 2016 9:33:20 PM LAYOUT: FP7

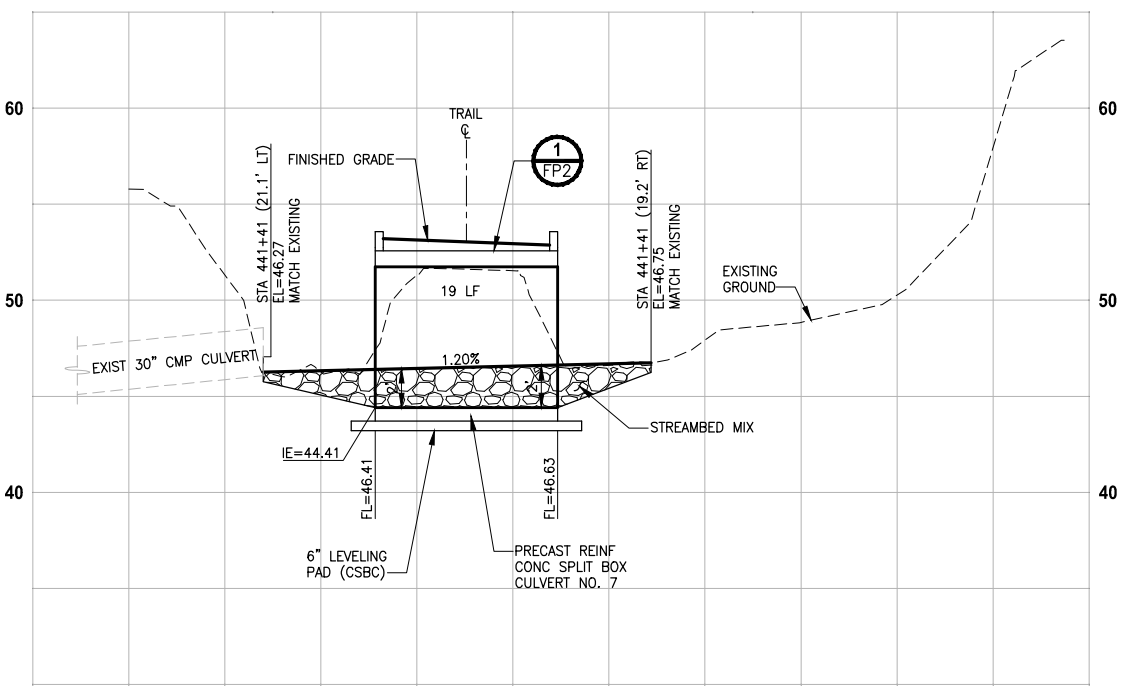


**GEORGE DAVIS CREEK**  
**PLAN**  
 SCALE IN FEET  
 0 10' 20'

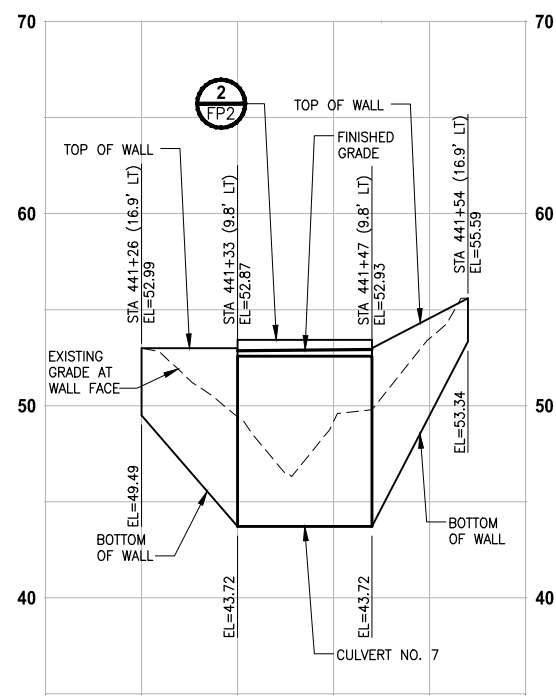


**GEORGE DAVIS CREEK**  
**TYPICAL SECTION**  
 NO SCALE

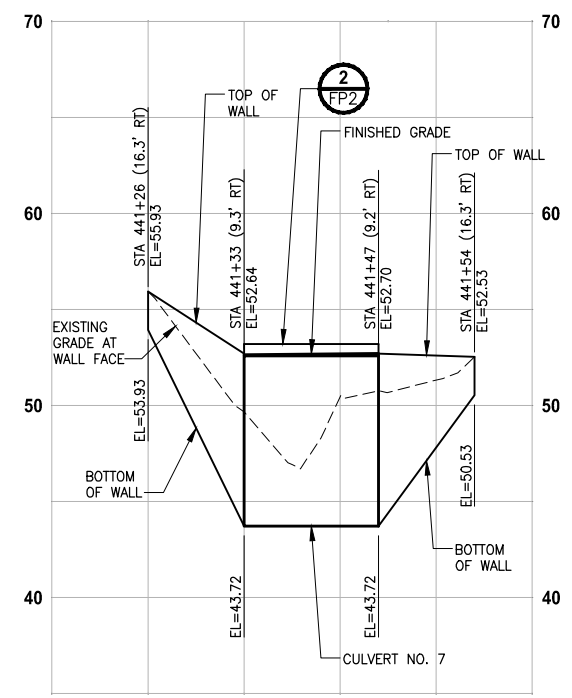
- NOTES:**
- CONSTRUCTION ACTIVITY FOR CULVERTS SHALL NOT OCCUR UNTIL AFTER STRUCTURAL ENGINEERING APPROVAL IS OBTAINED.
  - BOX CULVERTS AND STREAM WORK BELOW ORDINARY HIGH WATER LINE SHALL ONLY OCCUR BETWEEN JUNE 16 AND SEPTEMBER 30 PER HPA APPROVAL CONDITIONS IN APPENDIX B OF THE SPECIAL PROVISIONS.



**GEORGE DAVIS CREEK**  
**PROFILE D-LINE STA 441+40**  
 HORIZ: 1"=10'  
 VERT: 1"=5'



**GEORGE DAVIS CREEK**  
**PROFILE CULVERT 7 WING AB**  
 HORIZ: 1"=10'  
 VERT: 1"=5'



**GEORGE DAVIS CREEK**  
**PROFILE CULVERT 7 WING CD**  
 HORIZ: 1"=10'  
 VERT: 1"=5'

CITY OF SAMMAMISH APPROVAL	
City Engineer _____	Date _____
Community Development _____	Date _____

**60% REVIEW SUBMITTAL**  
 NOT FOR CONSTRUCTION

REVISIONS	DATE	BY	DESIGNED
			C. BUITRAGO
			B. PURGANAN
			P. JOHANNESSEN
			Y. HO

**ONE INCH AT FULL SCALE, IF NOT, SCALE ACCORDINGLY**  
 FILE NAME: BL1521075P19T03FP-01  
 JOB No.: 554-1521-075 P19 T03  
 DATE: SEPTEMBER 2016



**Parametrix**  
 ENGINEERING · PLANNING · ENVIRONMENTAL SCIENCES  
 719 2ND AVENUE, SUITE 200 | SEATTLE, WA 98104  
 P 206.394.3700  
 WWW.PARAMETRIX.COM

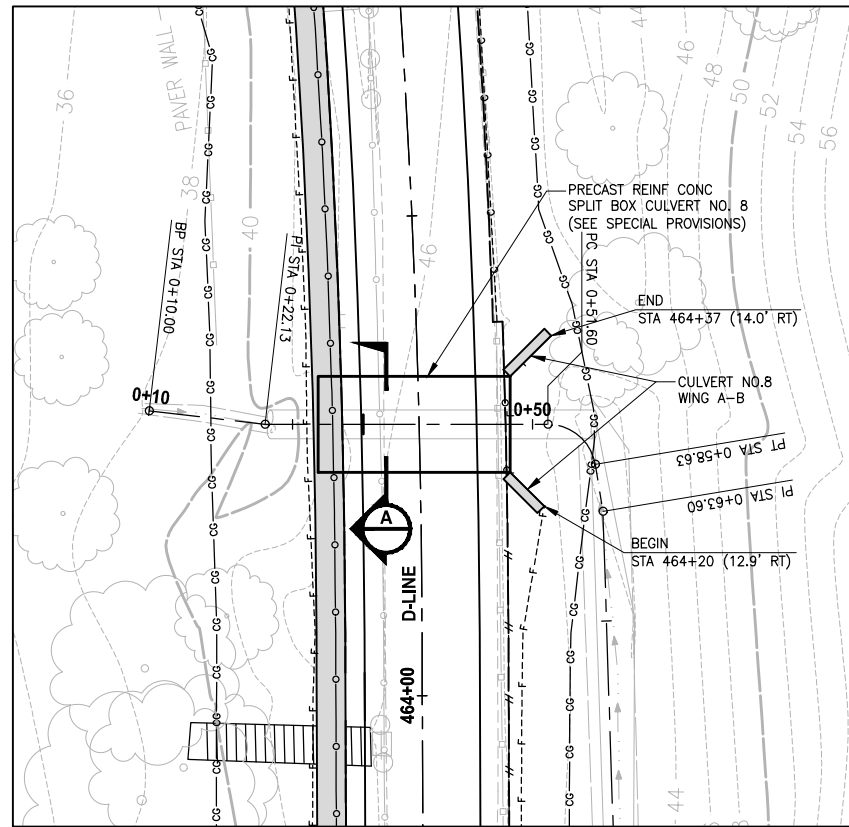
PROJECT NAME  
**EAST LAKE SAMMAMISH MASTER PLAN TRAIL SOUTH SAMMAMISH SEGMENT B**  
 SAMMAMISH, WA

**FISH PASSAGE CULVERTS**  
 FP7

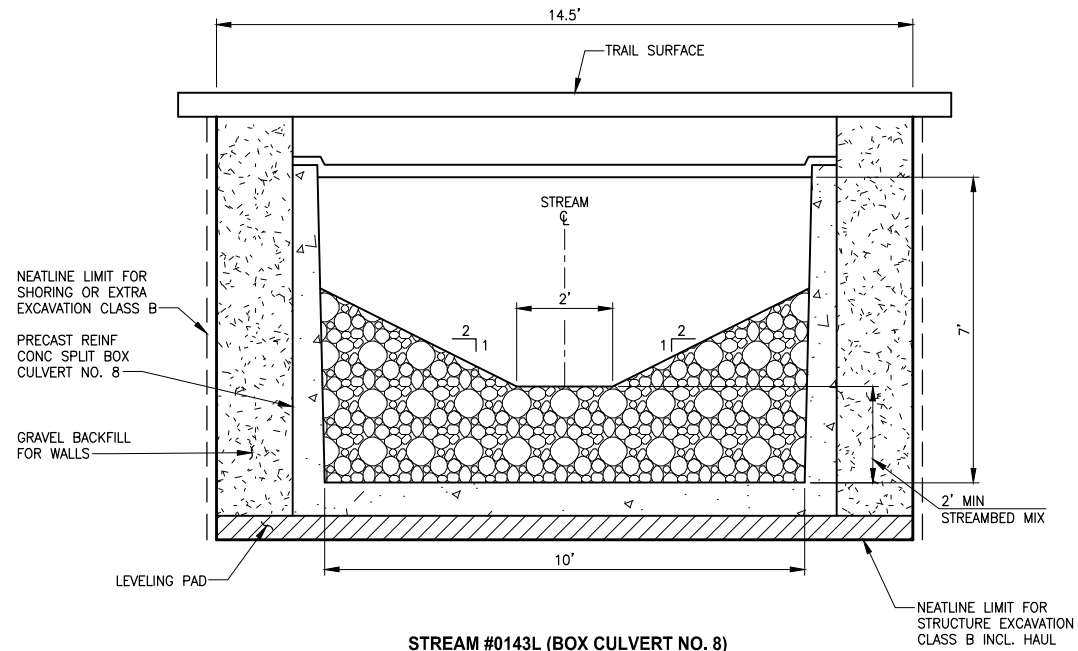
SHEET NO.  
 83 OF 135



PATH: U:\P50\Projects\Clients\1521-KingCo\554-1521-075-ELST\99Secs\CADD\Phase 19\T03\_Civil\Draw\ PLOTTED BY: purgabat DATE: Wednesday, October 12, 2016 9:33:51 PM LAYOUT: FP8



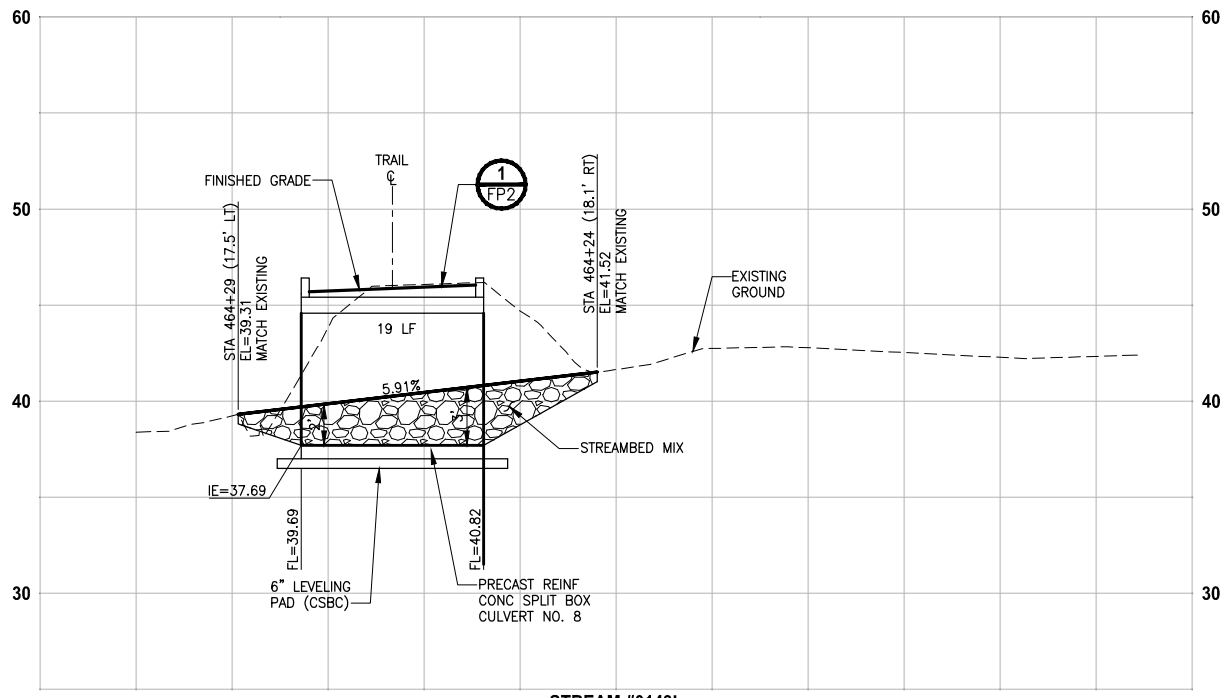
**STREAM #0143L**  
**PLAN**  
 SCALE IN FEET  
 0 10' 20'



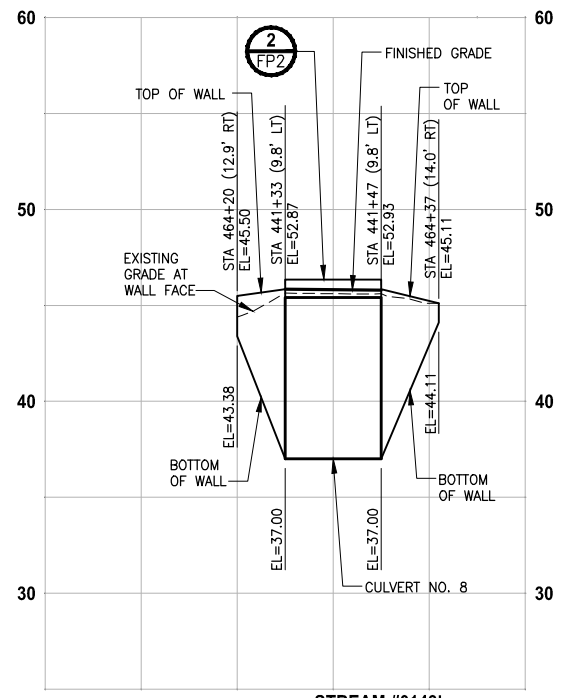
**STREAM #0143L (BOX CULVERT NO. 8)**  
**TYPICAL SECTION A**  
 NO SCALE

**NOTES:**

- CONSTRUCTION ACTIVITY FOR CULVERTS SHALL NOT OCCUR UNTIL AFTER STRUCTURAL ENGINEERING APPROVAL IS OBTAINED.
- BOX CULVERTS AND STREAM WORK BELOW ORDINARY HIGH WATER LINE SHALL ONLY OCCUR BETWEEN JUNE 16 AND SEPTEMBER 30 PER HPA APPROVAL CONDITIONS IN APPENDIX B OF THE SPECIAL PROVISIONS.



**STREAM #0143L**  
**PROFILE D-LINE STA 464+28**  
 HORIZ: 1"=10'  
 VERT: 1"=5'



**STREAM #0143L**  
**PROFILE CULVERT 8 WING AB**  
 HORIZ: 1"=10'  
 VERT: 1"=5'

CITY OF SAMMAMISH APPROVAL	
City Engineer _____	Date _____
Community Development _____	Date _____

**60% REVIEW SUBMITTAL**  
 NOT FOR CONSTRUCTION

REVISIONS	DATE	BY	DESIGNED
			C. BUI TRAGO
			B. PURGANAN
			P. JOHANNESSEN
			Y. HO

**ONE INCH AT FULL SCALE, IF NOT, SCALE ACCORDINGLY**  
 FILE NAME: BL1521075P19T03FP-01  
 JOB No.: 554-1521-075 P19 T03  
 DATE: SEPTEMBER 2016



**Parametrix**  
 ENGINEERING · PLANNING · ENVIRONMENTAL SCIENCES  
 719 2ND AVENUE, SUITE 200 | SEATTLE, WA 98104  
 P 206.394.3700  
 WWW.PARAMETRIX.COM

PROJECT NAME  
**EAST LAKE SAMMAMISH**  
**MASTER PLAN TRAIL**  
**SOUTH SAMMAMISH SEGMENT B**  
 SAMMAMISH, WA

**FISH PASSAGE CULVERTS**

SHEET NO.  
 84 OF 135  
**FP8**



DRAFT

## Appendix B

Offsite Analysis Descriptions, Drainage  
Problems and Complaints





Appendix B - Offsite Analysis Descriptions

Downstream Analysis

East Lake Sammamish Master Plan Trail, South Sammamish Segment B

Date: 4/16/2013, 4/25/2013, and 6/20/2014

TDA	Type of Outfall	Station	Description (Upstream)	Description (Downstream)	Owner	Comments
10	sheet flow (infiltration)	283+00 to 287+75	18" Pipe conveys roadway runoff under ELSP to the vegetated slope at the north east corner of SE 33rd Street intersection. There will not be any backwater effects created by the project in this TDA.	There was no flow path identified from the existing trail. It is expected that existing trail runoff infiltrates into the vegetated ground adjacent the trail, between the trail and East Lake Sammamish Shore Lane SE. Runoff that does not infiltrate into the ground sheet flows to the ditch located east of East lake Sammamish Shore Lane SE. The ditch has no culvert outlet, therefore, runoff is assumed to infiltrate.	Krosenkranius; Demers	Class B Well (Drinking Water) is located on Demers Property There are no wetlands in this area. No drainage or water quality problems were observed nor predicted. No drainage complaints have been documented in this area.
11	24" Storm drain	290+00	Watercourse is conveyed under ELSP in a 24" culvert, then flows in an open channel for approximately 10 feet before flowing to the 24" trail culvert near Station 290+00. There will not be any backwater effects created by the project in this TDA.	Runoff from the trail and offsite drainage area flow to the 24" trail culvert near Station 290+00. There is a 5 foot vertical drop at the outlet onto a concrete splash pad. Water flows into Type 2 Catch Basin with a Bird Cage Gate. From this drainage structure, runoff is conveyed in an enclosed drainage system to the lake at a location on private property.	Krosenkranius	The culvert needs to be replaced due to broken ends. The downstream property is a Tract parcel that does not have a building. There are no wetlands in this area. No drainage or water quality problems were observed nor predicted.
12	8" Storm drain	298+85	Runoff from Driveway #9 is collected in a rectangular grated catch basin, and is conveyed downstream. There will not be any backwater effects created by the project in this TDA.	Trail runoff is collected in a shallow ditch east of the trail and is conveyed toward Driveway #2. Culverts convey ditch runoff to the catch basin at the northeast corner of Driveway #2. An 8" diameter storm drain conveys collected runoff west to the lake via private drainage system.	Buck	There are no wetlands in this area. No drainage or water quality problems were observed nor predicted.
13	sheet flow	300+25 to 304+65	N/A	No distinct, existing drainage pathways. Runoff drains to adjacent landscaping vegetation.	multiple owners	No erosion or flooding noted.
14	sheet flow	304+65 to 308+25	A private enclosed drainage system conveys upstream runoff through trail corridor near Station 308+10 via an 18" storm drain, and discharges to the lake via a rock lined ditch on private property.	No distinct, existing drainage pathways. Runoff drains to adjacent landscaping vegetation.	multiple owners	No erosion or flooding noted.
15	sheet flow	308+25 to 309+25	N/A	No distinct, existing drainage pathways. Runoff drains to adjacent landscaping vegetation.	Miller	No erosion or flooding noted.
16	sheet flow	309+25 to 311+00	N/A	No distinct, existing drainage pathways. Runoff drains to adjacent landscaping vegetation.	multiple owners	No erosion or flooding noted.
17	sheet flow	311+00 to 312+90	N/A	No distinct, existing drainage pathways. Runoff drains to adjacent landscaping vegetation.	multiple owners	Property owner, Reinhardtsen (2805 East Lake Sammamish Parkway SE), near Station 311+50, noted that there is a storm drain pipe under the trail from the east portion of his property to the west portion. No erosion or flooding noted.

Appendix B - Offsite Analysis Descriptions

TDA	Type of Outfall	Station	Description (Upstream)	Decription (Downstream)	Owner	Comments
18	sheet flow	312+90 to 314+00	N/A	No distinct, existing drainage pathways. Runoff drains to adjacent landscaping vegetation.	Salemann	Property owner, Salemann (2721 E Lake Sammamish Parkway SE), commented that puddles form on the trail when it rains, and "a sheet of water does go onto my house." From the site walk there was no indication that trail runoff shoots onto the homes of the neighboring property. No erosion noted.
19	Unnamed Stream #4	316+20	From the east side of the trail, water flows northward through a 12" culvert that daylights into Wetland 15C. Water from the wetland is conveyed under the trail in an 18" culvert.	The culvert daylights on the west side of the trail into an open channel for a approximately 7 feet, then enters a 12" culvert for 18 feet, and finally daylights in an open channel that flows to Lake Sammamish.	Rundle	No erosion or flooding noted.
20	Unnamed Stream #5	316+95	A 12" CMP discharges water from a wall on the east side of the trail near station 323+00. The water flows south adjacent to the trail, crosses in an 8" culvert under SE 26th St. and continues south into Wetland 15C. Wetland 15C drains to a 24" culvert under the trail at station 316+70. There will not be any backwater effects created by the project in this TDA.	The culvert daylights on the west side of the trail into an open channel that flows to Lake Sammamish.	Rundle	No erosion or flooding noted.
21	unknown	327+00	Stormwater flows north along both sides of the trail. The west ditch crosses at station 324+50 in a 12" culvert. The water flows through a 12" culvert under a driveway at 325+60 and into another ditch that ends at Sta. 327+00 and drains into four stacked 6" PVC pipes. There will not be any backwater effects created by the project in this TDA.	The flow path from the stack of 6" PVC pipes is unknown because the downstream end of the pipes was not found. Downstream of the PVC pipes is the closed depression that makes up a property owners yard near station 328+50, and to the west is the Lake Sammamish shoreline.	multiple owners/Lake Sammamish	No erosion or flooding noted.
22	sheet flow	328+26 to 333+90	East of the trail is a series of depressed yards that do not appear to have drainageways to the lake. The depressions are approximately 8 to 10 feet below the trail elevation. There will not be any backwater effects created by the project in this TDA.	No distinct, existing drainage pathways. Runoff drains to adjacent landscaping vegetation and Lake Sammamish.	Lake Sammamish	No erosion or flooding noted.
23	sheet flow	333+90 to 338+00	N/A	No distinct, existing drainage pathways. Runoff drains to adjacent landscaping vegetation, over private lawns and to Lake Sammamish.	Chow; Haluptzok	No erosion or flooding noted.
24	sheet flow	338+00 to 342+00	N/A	No distinct, existing drainage pathways. Runoff drains to adjacent landscaping vegetation, over private lawns and to Lake Sammamish.	Bolles; Hess & Larson; Lake Sammamish	No erosion or flooding noted.

Appendix B - Offsite Analysis Descriptions

TDA	Type of Outfall	Station	Description (Upstream)	Description (Downstream)	Owner	Comments
25	sheet flow	342+00 to 347+50	N/A	No distinct, existing drainage pathways. Runoff drains to adjacent landscaping vegetation, over private lawns and to Lake Sammamish.	Lake Sammamish; Waggoner; Sun & Chen; Tan; Chamberlin	No erosion or flooding noted.
26	sheet flow	347+50 to 349+90	N/A	Runoff sheet flows toward Wetland 19B (private lawns) and to Lake Sammamish.	Apel; Peterson; Kilgore	No erosion or flooding noted.
27	8" Storm drain	350+45	N/A	Trail runoff is collected in a shallow ditch east of the trail and is conveyed toward a catch basin located near STA 350+50. An 8" diameter storm drain conveys collected runoff west and discharges toward the lake on private property.	Beluche	No erosion or flooding noted.
28	12" Storm drain	352+50	N/A	Trail runoff is collected in a shallow ditch east of the trail and is conveyed toward a catch basin located near STA 352+50. An 12" diameter storm drain conveys collected runoff west and discharges to Wetland 20B (on private property), which flows to the lake.	Pietromonaco; Rowe; Roberts	No erosion or flooding noted.
29	Unnamed Stream #6	356+90	The stream flows toward the trail from the Sammamish plateau east of the project area, beneath East Lake Sammamish Parkway in a culvert, through non-developed vegetated areas with moderate to steep slopes, and through another culvert beneath East Lake Sammamish Place SE before entering Wetland 21B in the project area. Wetland 21B flows to the 18" diameter culvert that conveys the channel beneath the trail.	The 18" diameter culvert daylights on the west side of the trail into an open channel that flows through Wetland 21A to Lake Sammamish.	Eden; McKulka; Rissberger; Glasenapp; Owens; Chee; Jacomet	No erosion or flooding noted.
30	sheet flow	359+75 to 361+15	N/A	Runoff sheet flows west over lawns (King County owned and private) and to Lake Sammamish.	Boitano; Sandstrom	
30A	4" Storm drain	361+35	Runoff from private properties east of trail flows to ditch that flows north through Wetland 22B to an 8" diameter culvert near Sta. 361+60. There is a catch basin structure in the ditch near Sta. 361+05 that is full of standing water, mud and a 12" diameter storm pipe from the north and south that are both plugged with mud. The south pipe is assumed to come from private property to the southeast. The pipe to the north flows to a mostly plugged pipe end near Sta. 361+20. Runoff continues north in the ditch through Wetland 22B to an 8" diameter culvert near Sta. 361+60 that flows west beneath the trail.	The 8" culvert enters a small, 1'x1' plastic box, yard drain structure west of the trail near Sta. 361+60. From this structure, a 4" drain pipe flows west and although the connections were difficult to determine in the field, the most logical connection is to the catch basin located in East Lake Sammamish Shore Lane SE near Sta. 361+35. This structure has many connections 4" drain pipes from all four directions. Therefore, it is assumed that this structure receives local yard drainage and trail runoff, and discharges west to Lake Sammamish through private property via the 4" drain pipe.	Sandstrom; Tsilas	Drainage complaints from property owner Tsilas regarding runoff from East Lake Sammamish Shore Lane and from the trail culvert overflowing catch basins located in the driveway and toward their home.



Appendix B - Offsite Analysis Descriptions

TDA	Type of Outfall	Station	Description (Upstream)	Description (Downstream)	Owner	Comments
31	18" Storm drain	364+25	Wetland 22AB east of the trail flows to the 18" diameter culvert located near Sta. 364+25.	The 18" diameter culvert flows west beneath the trail, East Lake Sammamish Shore Lane SE, and the home on private property at 1411 East Lake Sammamish Parkway SE. The culvert daylights at the west side of the trail into an open channel that flows through Wetland 21A to Lake Sammamish.	Fletcher	There are no documented drainage complaints regarding the culvert, but neighbors have expressed concern that runoff from East Lake Sammamish Shore Lane SE sometimes creates a nuisance. The project design does not propose to modify this access road, therefore, runoff problems related to roadway drainage collection are not considered as part of the project design.
32	Unnamed Stream #7	367+00	Runoff from the Sammamish Plateau flows west through a large wetland complex east of East Lake Sammamish Parkway, beneath the parkway through a 36" diameter culvert, and in an open channel for approximately 30 feet before reaching the inlet of the 12" diameter trail culvert.	The 12" diameter trail culvert daylights west of the trail near Sta. 367+00 in an open concrete box for less than 5 feet before entering another 12" diameter culvert that flows west, beneath East Lake Sammamish Shore Lane SE, before daylighting in a rock lined open channel between the houses on private properties at 1317 East Lake Sammamish Shore Lane SE and 1309 East Lake Sammamish Shore Lane SE. The exact trajectory of the pipe or if the pipe enters a drainage structure between the inlet, west of the trail, and the outlet on private property is unknown.	Moore; Easley; Birrell; Christensen	Reports of channel flooding were reported by home owner Christensen (1309 East Lake Sammamish Shore Lane SE) in March 2003. The complaints stated that the problem was due to the large culvert beneath the parkway allowing large volumes of water to the downstream properties. The City Staff commented that the problem was due to a partially plugged trail culvert that was jetted out as response to the complaint. Maintenance staff now keeps the culvert from being plugged, and there have been no complaints since.
33	12" Storm drain	370+25	Runoff east of trail flows through ditch located in Wetland 22 CD to a catch basin located near Sta. 370+25. This area has been modified by adjacent private property owners, so the existing ditch and catch basin are buried beneath drain rock. Runoff collected in the catch basin flows west beneath the trail via a 12" diameter storm pipe.	The 12" diameter storm pipe enters a catch basin located in East Lake Sammamish Shore Lane SE near trail Sta. 370+30. From this catch basin the storm system flows west via a 6" diameter pipe between private properties 1221 East Lake Sammamish Shore Lane SE and 1219 East Lake Sammamish Shore Lane SE, and discharges to Lake Sammamish.	Christensen; Lindquist; Helling; Landry; Daugherty; Witty	No erosion or flooding noted.
34	12" Storm drain	371+75	Runoff east of trail flows south through the ditch located in Wetlands 23A and 23C to a 12" diameter culvert located near Sta. 371+75.	The 12" diameter culvert daylights east to a landscaped slope that does not have a defined channel, but also shows no signs of erosion. Conveyed runoff flows over a short rockery onto East Lake Sammamish Shore Lane SE. Driveway runoff flows north along the center of the pavement to an area drain catch basin that has a 4" diameter drain pipe that conveys north to the property boundary at 1203 East Lake Sammamish Shore Lane SE before turning west and discharging to Lake Sammamish.	Rodgers; Madgett; Hild; Farrar; Kessden; Arsheed; Reddy	No erosion or flooding noted.

Appendix B - Offsite Analysis Descriptions

TDA	Type of Outfall	Station	Description (Upstream)	Description (Downstream)	Owner	Comments
35	Pine Lake Creek	378+80 to 382+00	Pine Lake Creek flows to the project site from Pine Lake on the Sammamish Plateau, beneath the parkway in a 96" diameter concrete culvert and a parallel 36" diameter concrete culvert before entering the project site. The ditch located east of the trail in Wetland 24A flows south to the stream near Sta. 379+10.	The stream flows beneath the trail in two parallel, 36" diameter concrete culverts, before daylighting to an open channel that flows for approximately 150 feet before entering one 36" diameter concrete culvert that conveys the stream beneath the private property access road. Downstream of this road, the culvert discharges to an open channel that is bordered on each side by large redwood trees. The stream continues as an open channel to Lake Sammamish.	Gill Trust	No erosion or flooding noted.
36	12" Culvert	384+25	Unnamed Stream #8 (South Fork) crosses under ELSP in a 24" culvert. From there the flow splits and becomes the north and south fork of Unnamed Stream #8. The south fork flows directly toward the trail.	Wetland crosses trail in 12" culvert. Daylights briefly before entering private downstream pipe. Neighbor says developments have increased flows. The open channel downstream of the trail has been regraded and the riparian area cleared and replanted. The stream shows no signs of scour.	Chamberlin	
37	36" Pipe	386+60	Same as TDA 36.	Wetland 24C and the north fork of Unnamed Stream #8 drain into a 36" pipe that connects to a Type 2 CB west of the trail, and travels across private property to Lake Sammamish. No known drainage problems.	Enose	
38	Sheet flow	N/A	No concentrated flow enters from upstream.	No concentrated discharge.	Shroeder	
39	Sheet flow	N/A	No concentrated flow enters from upstream.	No concentrated discharge.	Hua; Kaushagen	
40	Sheet flow	N/A	No concentrated flow enters from upstream.	No concentrated discharge.	various	
41	16" pipe	401+70	Stream #0155 crosses under ELSP in an 18" pipe and flows into an open channel that flows southward along the trail for approximately 100' before entering the birdcage structure in Wetland 25A.	Stream enters type 2 catch basin with a bird cage trash rack. Water is conveyed in a 16" pipe under the trail and flows through a second structure and then onto private property to the lake.	Lane	
42	4" pipe	402+60	No concentrated flow enters from upstream.	Runoff from the trail sheet flows westerly off of the trail into a vegetated area. Runoff continues to flow west until it runs into a driveway within the King County ROW. An area drain on the west side of the driveway collects runoff into a 4" pipe that drains across private property to the lake.	Ertemalp	
43	4" pipe	404+10	No concentrated flow enters from upstream.	Runoff from the trail sheet flows westerly off of the trail into a vegetated area. Runoff continues to flow west until it runs into ELS Shore Lane. An area drain collects runoff into a 4" pipe that drains across private property to the lake. The area drain is currently set above the gravel driveway elevation and does not collect water until it ponds high enough to overtop the drain.	Dhinsa	Drainage problem - ponding on Shore Lane.
44	4" pipe	405+40	No concentrated flow enters from upstream.	Runoff from trail sheet flows west and is intercepted by Shore Lane. Runoff from Shore Lane enters a yard drain and is conveyed to the lake via a 4" pipe. Capacity is adequate. The project will not increase the area draining to this outfall.	Bell	

Appendix B - Offsite Analysis Descriptions

TDA	Type of Outfall	Station	Description (Upstream)	Description (Downstream)	Owner	Comments
45	4" pipe	405+80	No concentrated flow enters from upstream.	Runoff from trail sheet flows west and is intercepted by Shore Lane. Runoff from Shore Lane enters a yard drain and is conveyed to the lake via a 4" pipe. Capacity is adequate. The project will not increase the area draining to this outfall.	Fortini	
46	4" pipe		No concentrated flow enters from upstream.	Runoff from the trail sheet flows westerly off of the trail into a vegetated area. Runoff continues to flow west until it runs into a driveway within the King County ROW. A yard drain on the west side of the driveway collects runoff into a 4" pipe that drains across private property to the lake.	Gilbo	
47	Ebright Creek (open channel)		Ebright Creek crosses ELSP in two 30" culverts. The creek flows approximately 70' in an open channel before entering two 36" pipes crossing the trail.	Ebright Creek open channel to lake.	Eberhardt	
48	Sheet flow		No concentrated flow enters from upstream.	Runoff from the trail sheet flows west into adjacent vegetation. There are no concentrated outfalls.	various	
49	Sheet flow		No concentrated flow enters from upstream.	Runoff from the trail sheet flows west into adjacent vegetation. There are no concentrated outfalls. ELS Shore Lane lies adjacent to the KC ROW. There is no stormwater collection system in the roadway. Runoff from the road sheet flows west into various properties.	various	
50	Zaccuse Creek (open channel)	424+55	Zaccuse Creek crosses under ELSP in a 36" culvert. The creek flow approximately 35 feet in an open channel before crossing under the trail in a 36" culvert. Downstream of the culvert, the stream flows in an open channel for 30 feet before crossing Shore Lane.	Zaccuse Creek crosses under ELS Shore Ln under a small box culvert , then daylights on private property downstream (City project).	Weber/Bunche	
51	Sheet flow	425+00	No concentrated flow enters from upstream.	Runoff from the trail sheet flows west from the trail into adjacent vegetation. There is a paved parking area within the ROW and Wetland 26B. Runoff that does not infiltrate appears to continue to flow west towards ELS Shore Lane, which is outside the ROW. There is no collection system on Shore Lane. There is a low area near station 425+00. Water appears to flow towards this area and then flows west into private properties to the lake.		
52	Sheet flow		No concentrated flow enters from upstream.	Runoff from the trail sheet flows west towards the lake. Runoff is mostly blocked by ELS Shore Lane. Runoff overtopping the roadway would continue towards the lake through various properties. There is no drainage collection system for Shore Lane.		

Appendix B - Offsite Analysis Descriptions

TDA	Type of Outfall	Station	Description (Upstream)	Description (Downstream)	Owner	Comments
53	Open channel	432+00	Runoff from the east side of ELSP crosses under the road in a 24" culvert. The waterway is in a riprap lined channel for approximately 35 feet before crossing under the trail in a 36" culvert. On the west side of the trail, water enters a manhole and drops down about 3 feet to the ground elevation.	Water exits the manhole and travels in an open channel to the lake.	Albright	
54	6" pipe	435+70	Upstream runoff enters this TDA from ELSP. Runoff crosses under ELSP in a 12" culvert that discharges into a ditch along the south side of Driveway #22. At the bottom of the driveway, the ditch turns south and runs along the trail to the 12" culvert crossing at Station 436+30. The downstream end of the culvert daylight into an asphalt parking area, where it enters an area drain a few feet away.	From there a 6" pipe conveys water south and then west down the driveway to 425 ELS LN. The pipe is blocked halfway down the driveway where a concrete boat ramp has been installed.		Drainage problem - Kotzenberg
55	30" pipe	441+40	George Davis Creek crosses under ELSP in a 60" culvert. On the east side of the parkway, there is a high flow bypass that carries floodwater to the north and then to the lake in a separate pipe. Normal flows enter a large manhole where the flows drop down before entering the culvert under ELSP. The creek flows in an open channel for 30 feet before crossing under the trail in two culverts (18" and 36").	Downstream of the trail the stream daylights for a few feet and then enters a 30" pipe that conveys the stream to the lake. The pipe passes underneath a driveway and a house before reaching the lake.		
56	6" pipe	446+60	No concentrated flow enters from upstream.	The trail mostly sheet flows towards the lake. There is a concrete pipe at the north end of Wetland 28E (Sta 446+60) that is directed north along the trail. A closed circuit camera was run through this pipe to determine where it goes. The concrete pipe ends approximately 10' north and a smaller 6" ADS pipe continues north. The camera could not proceed the full length of the pipe due to blockages; however the outfall was determined to be located in a terraced garden at house # 833 E. Lk. Sammamish Pkwy NE.	unknown	Pipe TV'd. Drainage flow path needs to be repaired. Proposed outfall through Buchanan property.
57	12" Pipe	450+00	Unnamed Stream #10 originates out of Wetland 28A. No channel was found upstream of ELSP.	Unnamed Stream #10 crosses under trail in a 24" Culvert. Continues in an open channel to the lake, except for a short culvert that crosses beneath a walkway.	Castor	
58	Unnamed Stream #11 (open channel)	453+00	Unnamed Stream #11 crosses under ELSP in a 24" pipe. No channel was found upstream of ELSP.	Unnamed Stream #11 crosses under the trail in a 24" pipe and daylights into Wetland 29C. The stream continues in an open channel to the lake.	Denton	
59	Unnamed Stream #12 (half pipe, 24")	454+50	Water enters the project area in a 24" pipe that crosses under ELSP.	Pipe system crosses trail and discharges into a 24" half pipe beneath the deck that drains to the lake.	Ness	
60	Unnamed Stream #13 (open channel)	455+80	Water enters the project area in a 30" pipe that crosses under ELSP.	The stream daylights for 20' before entering a 24" culvert beneath the trail. The stream daylights once again on the downstream side of the trail and is conveyed in an open channel to the lake.	Creevey	

Appendix B - Offsite Analysis Descriptions

TDA	Type of Outfall	Station	Description (Upstream)	Description (Downstream)	Owner	Comments
60A	8" pipe	456+40	Water enter the project area in a pipe that crosses under ELSP. The pipe travels beneath the gravel parking area east of the trail near Station 457+50. The pipe discharges toward the trail beneath a wall made of old concrete slabs stacked on each other, that holds up the parking area.	Property owner, Wolfe, described the existing drainage system as an 8-inch pipe being buried beneath the east trail ditch. The pipe flows south and turns 90 degrees, west beneath the trail near Station 456+30. The pipe flows beneath the trail and along the south property line of the home at 1111 East Lake Sammamish Parkway NE. The pipe discharges through a concrete bulkhead that serves as a partial foundation element to the home.	Wolfe, Hill	Drainage complaint of ponding water in Wetland 29D.
61	Stream #0143L (SF)(Open Channel)	460+25	Stream #0143L crosses under ELSP in a 24" pipe and diverges into two channels at the outfall of the pipe by a boulder tumble that dissipates energy from the culvert. The South Fork runs south along the trail in an open channel for 90' before crossing the trail in a 24" culvert.	The stream crosses under the trail and an adjacent driveway in a 24" culvert and then runs in an open channel on private property to the lake.	Rohbrach	
62	Stream #0143L (NF)(Open Channel)	464+30	The North Fork of Stream #0143L splits off and travels north along the trail in an open channel for 355' until it crosses under the trail in a 36" culvert.	The stream daylights on the west side of the trail and travels 80' in an open channel to the lake.	Gehring	
63						

Photos of downstream analysis:

\\parametrix.com\pmx\PSO\Projects\Clients\1521-KingCo\554-1521-075-ELST\Photos\Sammamish\Sammamish Drainage\Photos 2014-06-20



CITY OF SAMMAMISH DRAINAGE COMPLAINTS

ID	Date	Description	Assigned to:	Status	First Name	Last name	Email	Phone	Work phone	Cell	Address	State	Zip	City	Entered	Action	Days	Hrs	Type	Location	Neighborhood	crossx	crossy	repinc	Date closed	Date entered													
766	3/22/2002	notices a higher than normal volume of water in the drains and culverts draining onto his property. Wonders if drains should be somehow connected to Metro because he sees more erosion on his property. More noticeable on his neighbors property but is also affecting his.	Elafrance	CLOSED	William	Robins	mossadam	206-442-2650			2917 East Lake Samm Pkwy	Washington	98075	Sammamish	jsmith	3/23 Carter Reeve scheduling meeting with Mr. Williams to investigate problem.  5-14-02 Eric Adams: Conducted Site visit with resident. Took pictures and noted that some erosion had occurred over the last wet season. Resident pointed out that there appears to have been some modification made to the drainage on ELSP. I told the resident that I would contact the County to find when the modification was made and why.  7-11-02 ERL talked with Mr. Robins on the phone. Discussed what has been determined so far, and developed a plan for observing the problem. The plan includes waiting for the wet season to trace the upstream flows and determine whether or not they are being properly detained. CAR is on hold until the wet season.  3-09-04 ELF has been watching problem, and has not seen an increase in the flows in that area. Resident has not called back with water issues. Conclusion, this was a one time event that could be attributed to transitional upstream conditions. Case Closed			Drainage Problems																				
1542	1/31/2003	Ongoing problem with drainage runoff from Inglewood Hill Rd to E Lake Sammamish Parkway at the beach entrance owned by the Inglewood Plat Neighborhood. Runoff diverts off Parkway, across area where there is a chain length fence which is usually clogged up with leaves, which causes runoff to then divert down beach access, which is now eroding away, as is some of the hillside. This problem has been discussed with Dick Thiel and Carter Reeve previously. The problem is getting worse. Because of the runoff from the slope of Inglewood Hill Rd and the subsequent substandard drainage basin at the base of the hill on the Parkway, the water floods up and over the hillside. The City apparently dropped some gravel there last year to mitigate some of the erosion, but that was washed away by subsequent storms. The HOA then placed some more gravel and rocks, but that is eroding away as well.  He is asking that this be looked at once again and the City propose some nature of fix. He is also asking if the City would consider writing up something for his little HOA newsletter which he publishes in March (but the deadline is in February), which explains the City's response and whatever their plans are so that the members of the HOA can be communicated with and made to feel that the City is working with them on it.	dthiel	CLOSED	David	Willson		425-831-3520				Washington	Unknown	Sammamish	crupke	Colleen will discuss this further with Dick on Monday.  Eric, Glenn & I looked at this site this afternoon. We are going to modify the drainage from the Parkway so that it does not erode the trail down to the beach property, including installation of a french drain level spreader and rocking the eroded areas to stabilize them. A permanent solution would be to modify the drainage system on the Parkway itself, which would cost tens of thousands of dollars. We are not ruling out having to do this, but we want to try this local modification first.  We are in the process of selecting a consultant to prepare the Inglewood Subbasin Drainage Plan update, which will be complete in about a year. This study will detail the many drainage problems in the basin similar to this one, develop cost estimates, and prioritize them. Depending on how this quick fix works, we will develop a longer-term project. In the meantime, Glenn hopes to complete this work within 3-4 weeks.  I don't have an email address for Mr. Willson, could you call him or forward this information on to him? I hope it will be sufficient for him to write the article for his homeowners association newsletter.  Dick Thiel, PE., City Engineer City of Sammamish		1	Drainage Problems	Inglewood Hill RD & E Lake Sammamish Parkway NE	Inglewood Hill																		
1617	3/14/2003	Localized flooding	elafrance	CLOSED	Anne	Christansen		425.868.7178		206.356.92	1309 E. Lake Sam. Shore LN	Washington	98074	Sammamish	elafrance	ELF met with the resident onsite and assessed the problem. ELF called the County and informed them that a culvert needed jetting out. The County performed the work, and a follow up site visit confirmed that the culvert was not functioning and the flooding problem was relieved. Case Closed			Drainage Problems		Mint Grove																		
1625	3/18/2003	Citizen left voicemail message on Bradford Davis' phone, which was forwarded to Colleen:  Ann advised that her residence experienced severe flooding the day before yesterday following the heavy rains as a result of the huge culvert pipe that was installed under the Parkway following the earthquake. This culvert is directly behind her residence. This culvert directs water into the ditches that run along the proposed trail route on the lake. The ditches were insufficient for the water load that hit in the last heavy rains. As a result, the water flooded into her garage, her basement and main floor of her residence. They were ultimately able to redirect the water on that day, but she is requesting that someone come out and take a look at this problem and talk with her, as this cannot continue. She would like some remedy to be considered before this becomes a real big, on-going, nasty problem.	gakramoff	CLOSED	Ann	Christiansc		425-868-7178			1309 E LK Sammamish Sho	Washington	Unknown	Sammamish	crupke	Colleen forwarded copy of voice mail to John Cunningham for his information and left a message for Glenn on his voice mail requesting he contact Ann. Colleen will also forward a copy of this CAR to Eric, drainage engineer, for him to be aware in the event that Glenn needs to consult with him on the matter.  Completed.			Drainage Problems	1309 E LK Sammam	Mint Grove																		

CITY OF SAMMAMISH DRAINAGE COMPLAINTS

ID	Date	Description	Assigned to:	Status	First Name	Last name	Email	Phone	Work phone	Cell	Address	State	Zip	City	Entered	Action	Days	Hrs	Type	Location	Neighborhood	crossx	crossy	repinc	Date closed	Date entered			
1627	3/18/2003	Ms. Christens called and left a message about a flooding problem at her residence. She said that the new larger culvert that was installed under East Lake Sammamish Parkway during the earthquake repairs a couple of years ago is allowing larger volumes of storm runoff to come under ELSPKWay. This runoff is overwhelming the ditches and culverts along the trail and then it is running down into their yard, garage and house. It did this during the recent heavy rains. What can be done about this ?? ERIC -- would you please contact the Christens's and go out and take a look at this situation to see what we (or KC Parks with respect to the trail ditches and culverts) can do to eliminate this flooding problem ?? Thanx, John C.	elafrance	CLOSED	Ann	Christense		425.868.7178			1309 East Lake Sammamish	Washington	98075	Sammamish	jcunningham	This CAR is also listed as case 1617, see note for 1617, case closed			Drainage Problems		Mint Grove								
1681	4/7/2003	Concerned about the culvert near East Lake Sammamish Pk NE on the east side of 1103 E. Lake Sammamish Pkwy NE. Drainage concerns with the removal of the trees on the slope and the possible clogging because of the debris.	elafrance	CLOSED	E. James	Crely		(425) 868-7004			1103 E. Lake Samm Pkwy N	Washington	Unknown	Sammamish	rlitzau	ELF called and spoke with resident. Informed resident that the tree cutting was under code enforcement and that the debris will likely have to be removed as part of a restoration plan. ELF spoke with Evan and confirmed that the tree cutters had applied for a permit. ELF will work with Evan to ensure that debris will be removed. Case Closed			Drainage Problems										
1769	5/14/2003	Resident came in to notify the City of some filling that was taking place on her neighbor's property. Other neighboring properties also called in to report the filling, and their names are:  Betty Emmanuel 3447 ELSSL NE 868-6305 Nancy Way 3453 ELSSL NE 868-4759	elafrance	CLOSED	Hiedi	Bathum		425 836 8953			3445 E Lake Sam Sh Ln NE	Washington	98074	sammamish	elafrance	Conducted a site visit with Ronda Litzau, and took some pictures of the site. Searched our records for a building permit, but didn't find one. Called KC and made a records request for the original permit. ELF and Ronda have met onsite with an engineer that was hired to fix the drainage problem. Applicant will be coming in for a permit, case closed			Drainage Problems										
2041	9/26/2003	Manages a property at Monterey Condos. Catch basin at entry to condos is clogged.	gakramoff	CLOSED	Janna	Zaffarano		425-747-5900			3500 East Lake Samm Pkwy	Washington	Unknown	Sammamish	jsmith	10/10/03: Full of silt/water. Vactor (for sure) & Sodder (maybe) pipes.			Drainage Problems							10/30/03			
2089	10/21/2003	Citizen originally requesting to know what kind of allen wrench to get to pop the lid on his drainage basin. Colleen contacted Glenn who advised that a City crew member would come out and pop the lid for him. Citizen said he knows we're busy and this isn't an emergency, but his drainage basin needs cleaned out, is wondering if the City would do that as well. The drainage basin is behind his backyard at the above-listed address, drainage basin goes off of the hill behind his house.	gakramoff	CLOSED	John	Moses		425-369-0567			2133 E LK Sammamish PL SE	Washington	98075	Sammamish	crupke	Colleen left message on Glenn's cell phone asking if this is something we would clean out or if Colleen needs to re-contact this Citizen and advise him this is his responsibility.  Drain is working TT TLS			Drainage Problems		2133 E LK Sammamish PL SE						3/1/04		
2132	11/10/2003	Peggy Hughes, Charles sister-in-law phoned on behalf of Charles and herself to let us know that on East Lake Sammamish Pkwy North of NE 30th Ct there is a filled culvert so that water is being diverted onto the beach. You can see the culvert blockage a few yards south of the driveway at 3202 E Lk Samm Pkwy.  Peggy Hughes 425-868-0284 Charles Hughes 425-868-6147	gakramoff	CLOSED	Charles	Hughs		425-868-6147				Washington	Unknown	Sammamish	dlunde	Completed			Drainage Problems		3202 E Lk Samm Pkwy						5-5-04		
2250	1/5/2004	Email from Joe Wilson (KC) to Evanivi, Evan forwarded it on to Colleen and Delora as follows:  -----Original Message----- From: Wilson, Joe [mailto:Joe.Wilson@METROK.GOV] Sent: Monday, January 05, 2004 8:39 AM To: Evan Maxim Subject: FW: Present Drainage Problems  Evan - we received this notice prior to Christmas from one the trail consultants. Just to be sure that the city gets the info - I'm sending it to you so you can pass it on to the right person/people for consideration. We noticed a few drainage problems late last week, two affecting the parkway and one which may affect a residence.  1) Developing sinkhole in parkway shoulder: Sta 288+75 (725 feet north of SE 33rd Street). We observed a 2-foot deep, 2-foot diameter hole beneath the west guardrail, directly above the culvert. We checked it with a 3-foot long footing probe (1/2-inch diameter steel rod), which was pushed in easily to the full three feet. It appears likely that the parkway embankment fill is being washed out from	elafrance	CLOSED	Joe	Wilson	son@metro					Washington	Unknown		crupke	Delora directed the following:  Eric & Glenn - I need both of your attention to these drainage problems. Glenn - Please look at these areas and see what short term fixes need to be done to prevent further damage and to ensure public safety. Eric - I need you to look at these areas and determine what the long term solution might be and then we can discuss further. Thanks, Delora Kerber 9/29/05 Glenn's crew has addressed the sink hole north of SE 33rd.			Drainage Problems										

CITY OF SAMMAMISH DRAINAGE COMPLAINTS

ID	Date	Description	Assigned to:	Status	First Name	Last name	Email	Phone	Work phone	Cell	Address	State	Zip	City	Entered	Action	Days	Hrs	Type	Location	Neighborhood	crossx	crossy	repinc	Date closed	Date entered	
2315	1/29/2004	X 2005 SE 19th - Loree Estates flooding. X E Lk Samm Pkwy south of 212th there is a Landslide covering the roadway. X E Lk Samm Pkwy north lanes blocked at SE 24th X 2942 22nd PL SE across from Pine Lake - sediment into lake: Lauri at 425-391-3887 X 20014 Se 19th Street - Water over roadway, blocked retention drain area. Bob Hughes 425-392-9283 X Corner of 215th PL SE & SE 16th PL there is a culvert blocked.	dlunde	CLOSED	Citizens							Washington	Unknown	Sammamish	dlunde	4/12/05 Has been completed GA			Drainage Problems	Various						4/12/05	
2430	3/18/2004	Ms. Ferry spoke to Glenn A. with concerns that a culvert is plugged on E Lk Samm. Pkwy.	gakramoff	CLOSED	Denise	Ferry		(415) 456-6716			2690 E. Lk. Sammamish Pk	Washington	98074	Sammamish	lhachey	Glenn A. will respond to her call. Completed.			Drainage Problems	E. Lk. Samm. Pkwy NE							
2585	5/19/2004	Resident called and expressed a concern about some drainage coming off of the hillside.	elafrance	CLOSED	Renata	Bloom		206 234-7355			2626 ELSP NE	Washington	98074	Sammamish	elafrance	ELF scheduled a site visit to investigate the problem. The problem is a migrating stream. Work done to contain the flow would have to be a part of a stream restoration project. The stream is on private property. This was communicated to the resident. Case Closed			Drainage Problems								
2975	11/4/2004	Resident called and expressed some interest in the maintenance work that the County is performing on the ditches to the trail.	elafrance	CLOSED	Steve	Farrar					1116 ELSP SE	Washington	Unknown	Sammamish	elafrance	ELF Scheduled a site visit. ELF Conducted a site visit and met with Mr. Farrar. ELF confirmed that the work was done in accordance with the COS codes. ELF called Joe Wilson from KC and told him about the issues that Mr Farrar is having. Joe Wilson has retired from the County, and the new contact is Robert. ELF and Robert have been exchanging phone msgs. It appears that the County is willing to install a culvert to provide Mr Farrar ped access, but Mr Farrar may be unwilling to sign the permit because he feels that his rights for public access can't be denied. This is an issue between Mr Farrar and the County. Case Closed			Drainage Problems								
2977	11/4/2004	There is a culvert located on her property that goes under the road and dumps the water into Lk Samm. This is plugged up with gravel and the water that should be draining is actually flooding her driveway.	gakramoff	CLOSED	Lucille	Barnard		425-868-8847	425-883-2983		2642 E. Lk Samm Pkwy NE	Washington	98074	Sammamish	jlopez	Priority: Operational Timeline: ASAP Contact: 11/12/04 11 AM left message Clear Blackberry bushes from drain and determine blockage and removal Completed 11/16/04 Bob & Ryan			Drainage Problems							11/23/04	
3047	12/21/2004	Says that the drain is clogged in the ditch and is clogged pretty consistently. He's afraid that when it freezes it will create a hazard on the roadway.	elafrance	CLOSED	Anthony	Jacobs		425-466-0954			2910 E. Lk Samm Pkwy NE	Washington	98074	Sammamish	jlopez	Priority: Liability Timeline: ASAP Contact: Eric Lafrance Scope: Clean out ditch and culvert for flow assigned to KC 12/22/04 need permits 1/5/05 Cleaning completed 1/21/05 Completed project			Drainage Problems							1/21/05	
3788	1/30/2006	Plugged culvert at 264 East Lake Sammamish Parkway, 1 mile South of Thompson Hill Road, caller advising that his front yard at 264 ELSP is filling up and he believes it is due to a downstream plugged culvert.	gakramoff	CLOSED	Steve	Ferrar		425-260-4762			264 E LK Sammamish PKWY	Washington	Unknown	Sammamish	crupke	Colleen called Glenn with this information. CAR forwarded to Glenn Priority: Operational Timeline: ASAP Contact: Eric/Glenn talked with homeowner. Date Completed: 1/30/06 GA Scope: Cleared by King County Parks caused by trail construction. (Glenn has pictures)			Drainage Problems	264 E LK Sammamish Parkway						2/17/06	
4020	6/2/2006	Drainage problem. Water from the Parkway drains down his driveway when it rains. He is wondering if he can raise a storm sewer manhole on the parkway or something to divert the water away from his house. Wanted someone to come out and see him this afternoon for 20 minutes or so to take a look at the situation and give him some recommendation. He said he called the Water District and asked about raising the storm sewer manhole. They said they'd do it but they believed the City would shear it off when they did roadway improvements.	Elafrance	CLOSED	Mike	Rundell		425-466-3584			2701 E LK Sammamish PKW	Washington	98075	Sammamish	crupke	Colleen called Delora, Delora advised there is not staff available today to run out there and take a look at the situation. Request that Eric put Mr. Rundell on his list of people to get ahold of when time permits. Colleen called and left message for Mr. Rundell that she will give Eric the information and ask Eric to give Mr. Rundell a call and set up a time to come out and look at the problem. ERL conducted a site visit with Mr Rundle. The problem is an historic problem, and the City does not have the resources available to address this type of problem. Case Closed			Drainage Problems	2701 E LK Sammamish PKWY SE							
4451	12/27/2006	Citizen states they are frustrated that nothing has been done regarding the constant run-off of water at Thompson Hill Rd NE and E Lk Samm Pkwy NE. He states it is a result of City of Sammamish construction. He is very concerned that if there is a hard freeze, that intersection will become a skating rink. It was crazy-busy with Passports and calls, and I didn't get his name. But, he was very frutrated that nothing had been done on this.		CLOSED							Intersection E Lk Samm Pkw	Washington	98074		thudson			Drainage Problems	Thompson Hill Rd NE & E. Lk Samm Pkwy NE						2/27/09		
4507	1/8/2007	Mr. Dadvar visited CH today: There appears to be an excessive amount of water flow from a property along ELSP north of Louis Thompson Hill Rd. Even when it is not raining water is flowing down the hill side onto the Pkwy and pooling at the intersection of ELSP and LTHR. He would like someone to look into this problem. The 3rd property north of Louis Thompson is where the runoff seems to be occurring.	elafrance	CLOSED	Brian	Dadvar		206-650-6770			423 205th Ave NE	Washington	98074	Sammamish	lhachey	This is within the project limits of the Thompson Signal Project, so I am forwarding it on to the current project manager, Steven Chen --ELF(1-8-07) 1/8/07 Steven visited the site. This drainage issue is not project related for the Signal project. It appears that the water is running off from a private property that is north of the slide area. Steven forwarded this to Eric LaFrance for storm water investigation. --SWC.			Drainage Problems	ELSP @ Louis Thompson						2/20/07	

CITY OF SAMMAMISH DRAINAGE COMPLAINTS

ID	Date	Description	Assigned to:	Status	First Name	Last name	Email	Phone	Work phone	Cell	Address	State	Zip	City	Entered	Action	Days	Hrs	Type	Location	Neighborhood	crossx	crossy	repinc	Date closed	Date entered		
4774	3/12/2007	On line CAR received: Description: This morning I noticed a flood of water coming across our road (E. Lake Sammamish Place) and onto the lawn of the property next to the road (1929 E. Lake Sammamish Place). The water is being pumped or drained from a new house being constructed on the hill above (on E. Lake Sammamish Parkway). I don't know how serious this is, but it doesn't seem like "kosher" contractor practices are being followed. Location: The problem: 1929 E. Lake Sammamish Place The source: House on E. Lake Sammamish Parkway visible just east of 1929 E. Lake Sammamish Place	Scezar	CLOSED	Jody	Wood	wood@msn	425-391-4041			2200 190th Place SE	Washington	98075	Sammamish	tsmith	3/12/07 Eric states this is Comm. Dev. Teresa spoke with Lisa and she said to give it to Steve Belzak. She also checked the parcel above said address and it may be at 2001 E. Lk Sammamish Parkway SE. TLS			Drainage Problems							3/12/07		
5243	11/26/2007	Mrs. Castor reports that sometime over this weekend a motorist went in the ditch in front of her property and apparently covered up the culvert in doing so, and now the ditch is all backed up with water and needs repair. Would appreciate if someone would come out ASAP and take a look at it and repair.		CLOSED	Shari	Castor		425-868-1759			845 E Lk Sammamish Park	Washington	98074	Sammamish	crupke	Forwarding to Michelle and Charlie to schedule ASAP			Drainage Problems	845 E Lk Sammamish Parkway NE						1/30/09		
5259	12/3/2007	Citizen states that the culvert between the Parkway and the Sammamish trail near their house at 264 E Lk Sammamish Pkwy SE is filling up. There is run-off from it that is flowing into their yard.		CLOSED	Karin	Ferrari			Work 425-837-740		264 E Lk Sammamish Pkwy SE	Washington	98075		thudson				Drainage Problems						1/30/09			
5260	12/3/2007	Citizen states there is a drainage/runoff problem at the foot (west) of his property. He states there is a ditch/culvert between his property and the Sammamish Trail. He states the water level has never been this high. He states there is a foot bridge that crosses the culvert and that water is about to cover the bridge step. He stated that he thinks the problem is that the drain that is there is plugged. He called King County, but they directed him to us. It would seem that this area would fall under King County Parks. He would like someone to contact him as soon as possible to let him know status.		CLOSED	Tony	Chee		425-427-9806		06-854-121	1605 E Lk Sammamish PI SE	Washington	98075		thudson				Drainage Problems						1/30/09			
5398	2/7/2008	Description: The ditch along the roadway is filled in with debris such as leaves, sticks, dirt and garbage. When it rains the water runs over the road because the culvert is so filled in that there is nowhere for the water to go. Location: It is the culvert along Louis Thompson Road and 211th Place SE intersection at the entrance to Tamarack Development and across from Montage Housing Development.		CLOSED	Brenda	Heath	th@comca	425-868-6835			21206 NE 4th Street	Washington	98074	Sammamish	tsmith	1/7/08 Teresa notified citizen. TLS			Drainage Problems	Culvert		Thompson	211th Place SE				3/3/09	
5798	7/22/2008	Ditch needs to be cleaned out. Project was started but never finished. On ELSP south of SE 8th on the West side. Could you please call him once you have created a work order to let him know approximately when someone might come out to look at this.  I DON'T BELIEVE this is in front of his house. PLEASE CALL him for more info.	csimpson	CLOSED	Walter	Brewer		425-885-2283	425-868-3194		815 E Lk Sammamish Shore	Washington	98075	Sammamish	lhachey	7/24/08 Corrected name and phone numbers. Please call this citizen to get specific info. TLS			Drainage Problems	ELSP @ SE 8th								
5913	9/17/2008	Jon Simpson has a project at 2905 E Lk Sammamish Pkwy SE. He indicates there is a culvert with an 18" pipe that empties out on the west side of the Parkway, essentially in front of his project, that needs to be unclogged. He states that there are Catch Basins to be installed as part of the project (one of which is near this culvert outlet). He would like the culvert cleared out to ensure efficiency. If there are any questions, you can contact Mr. Simpson. Or, the contractor (Rob) can be reached at 425-753-0196.	Csimpson	CLOSED	Jon	Simpson		425-503-6796				Washington	98075	Sammamish	thudson				Drainage Problems	West side of ELSP SE - 2900 block						Sep 17 2008 11:37AM		
6235	1/8/2009	Needs Sandbags ASAP. Will pick up if needed.	Kendelman	CLOSED	George	Burwell		425-868-8312			1415 E Lk Sammamish Ln SE	Washington	98074	Sammamish	dlunde	Will & Tonya delivered sand bags.			Drainage Problems							1/8/2009 8:46AM	Jan 8 2009 8:46AM	
6236	1/8/2009	Citizen requesting Sand Bags. Would like them delivered as soon as possible. Site address is in the Mint Grove development at 1415 E Lk Sammamish Ln. SE.	Kendelman	CLOSED	Kay	Breuel		425-868-8312		206245-040	1415 E Lk Sammamish Ln. SE	Washington	98075	Sammamish	thudson				Drainage Problems		Mint Grove					10/22/09	Jan 8 2009 8:59AM	
6237	1/8/2009	Culvert on the north side is clogged and starting to flood the roadway.	Kendelman	CLOSED	Barbara	Saario		425-868-5314				Washington	98074	Sammamish	dlunde	1/8/09 Cleared MDG			Drainage Problems		Thompson H	211th Pl				1/8/09	Jan 8 2009 9:47AM	
6238	1/8/2009	Needs sandbags (not IMMEDIATE emergency) delivered. She will call and update the car if her situation changes.	Jmarie	CLOSED	Cindee	Jobe		425-881-2209			1537 ELSP NE	Washington	98074	Sammamish	Jmarie				Drainage Problems							1/9/09	Jan 8 2009 11:16AM	
6240	1/8/2009	Needs more sand delivered. Called Kyle to let him know.	Kendelman	CLOSED	Rick	Visick		425-681-4321			1203 E Lk Sammamish Ln SE	Washington	98074	Sammamish	dlunde				Drainage Problems							1/9/09	Jan 8 2009 1:24PM	

CITY OF SAMMAMISH DRAINAGE COMPLAINTS

ID	Date	Description	Assigned to:	Status	First Name	Last name	Email	Phone	Work phone	Cell	Address	State	Zip	City	Entered	Action	Days	Hrs	Type	Location	Neighborhood	crossx	crossy	repinc	Date closed	Date entered											
6379	3/6/2009	On the morning of Friday, 3/6/09, ice formed across the northbound lane of ELSP just north of Louis Thompson Hill Road. It appears that this is the result of water flowing out of the drainage ditch on the east side of ELSP in this area and crossing the roadway. This morning's cold temperatures froze this water. Ditch appears to be plugged in this area.	Kendelman	OPEN	John	Cunningham	jcunningham@ci.samm	425-295-0560			801 228th Avenue SE	Washington	98075	Sammamish	jcunningham	3/6/09: Assigned to Kyle and Eric by JAC. Kyle/Eric is there something we can do here to keep this water from flowing out of the ditch and across the roadway ?? Can we dig the ditch out ?? Can we place an asphalt curb along the edge of the pavement to keep the water from crossing the pavement ?? Mark cross says that in this area the neighbor dumps their grass clippings in the ditch which may be clogging the ditch up. He also is wondering if the ecology block retaining wall we had King County build for us in this area is causing this problem.  From: Ho Le Sent: Friday, March 13, 2009 7:18 AM To: John Cunningham Cc: Kyle Endelman Subject: water over roadway thompson and parkway  John just wanted to let you know that I have sent the crew out yesterday to correct the situation on the bottom of Thompson hill. The crew has re-ditch and rocked the ditch line to get the water to flowing in the right direction and not onto the roadway. The Bank on the hill side will need to be address at a later date when it can dry up. Eric Lafrance and I meet on this issue on 3/10/09 and came up with two option.  1) To ditch and get the water to following off the roadway			Drainage Problems	East Lake Sammamish Parkway	Louis Thompson Hill Road																Mar 6 2009 11:31AM
6963	12/8/2009	Water frozen over her driveway from water overflowing from ditch. Needs someone to come clean out ditch.  Need to verify that it is Sammamish jurisdiction and not King County.	Kendelman	OPEN	Shari			425-868-1759			845 ELSP NE	Washington	98074	Sammamish	akoehnen				Drainage Problems									Dec 8 2009 2:33PM									
7176	5/3/2010	Kathy O'Brien 458 ELSP NE 206-852-8009  Standing water in the stormdrain in front of her home. Stormdrain grate is floating on top.	Lwerre	CLOSED	Kathy	O'Brien						Washington	98074	Sammamish	lwerre	Made site visit to assess standing water, Eric will contact homeowner about possible resolutions				Drainage Problems	458 ELSP NE							May 3 2010 8:17AM									
7583	12/1/2010	Water runoff problem, would like to hear options on a solution	Lwerre	CLOSED	Juana	Cundari		425-241-8064				Washington	98074	Sammamish	lwerre	Made site visit, listen to homeowners issue and after some research Eric will send an email with possible options				Drainage Problems	1601 E Lake Sammamish PL SE							Dec 1 2010 11:28AM									
7608	12/14/2010	Over flow at Inglewood creek, large amount of sediment going into lake	Elafrance	CLOSED	Zane	Myers						Washington	98074	Sammamish	lwerre	12/14/10 LW: EL inspected creek, was clear and clean at top, dirty and full of sediment at ponding area before crossing to go into lake. More investigation required, EL to follow up with Zane  12/15/10 LW: Crews unclogged at the flow splitter and reduced the amount of overflow				Drainage Problems	801 E LK SAMMAMISH PKWY NE							Dec 14 2010 7:37AM									
7786	3/22/2011	runoff coming from ELSP and damaging his driveway and home	Kendelman	OPEN	Fred	Horvath		425) 427-8397			2713 ELSP SE	Washington	98074	Sammamish	lwerre	Made a site visit and discussed options w Mr Horvath. Eric will talk to crews about shaving shoulder for better dispersion LW 3/23/11  Made a site visit and determined work had not been completed. Kyle please place this on the list to be done. Discuss with Eric for further details please. 12/8/11 LW				Drainage Problems	2713 ELSP SE							Mar 22 2011 10:22AM									
8286	3/15/2012	3/15/12 Citizen called to say that we spent a lot of time last year fixing a drainage problem on ELSP @ SE 24th (by 7-11 store). Right now there is an issue with the culvert, sounds like a cement truck is going thru the culvert, requesting someone take a look and evaluate. Thank you.	Elafrance	OPEN	Barry	Hayes		425-830-0936			2405 ELSP Place SE	Washington	98074	Sammamish	mgarcia	3/15/12 Work order was evaluated by Ho. Kyle said we need to re-direct the CAR to Eric.  Eric: We have not done any work at this location. Can you please investigate? Thanks Kyle.				Drainage Problems	ELSP @ SE 24th St							Mar 15 2012 2:34PM									
8337	4/24/2012	The ditch is deep enough and has culverts in it to keep water from the road, so there has never been an issue with flooding on the Parkway.  Would it be possible for someone from Public Works visit the site and determine if these rocks can be removed?	Elafrance	OPEN	Marie	Roberts		425-392-0773			2830 East Lake Sammamish	Washington	98074	Sammamish	lwerre	EL working on solution				Drainage Problems	2830 East Lake Sammamish Parkway SE							Apr 24 2012 11:50AM									



CITY OF SAMMAMISH DRAINAGE COMPLAINTS

ID	Date	Description	Assigned to:	Status	First Name	Last name	Email	Phone	Work phone	Cell	Address	State	Zip	City	Entered	Action	Days	Hrs	Type	Location	Neighborhood	crossx	crossy	repinc	Date closed	Date entered	
8390	6/15/2012	<p>Online CAR 6/14/12, received 6/15/12:</p> <p>Description: There is a property along E Lk Sammamish (maybe 665?) near the bottom of Inglewood Hill Rd that seemingly most of the year has run-off water trickling off of the property where their driveway meets the road, and this water runs over the surface of the road. In the winter this is an issue, because this water freezes up and we end up with a foot or two wide patch of ice that crosses the entire width of E Lake Sammamish. I've driven over it for the past 2 winters. Presumably its terrain runoff, but I'd expect it should be directed into the ditch there, not onto the roadway. Most days its damp or wet there if its not freezing outside. Mid summer is the only time its dry.</p> <p>Location: I think it is 665 E Lake Sammamish... its the hill side of the street, not the lake side of the street. A steep driveway angle down onto E Lk Sammamish there. <a href="https://maps.google.com/maps?q=47.617732,-122.067532&amp;ll=47.617752,-122.067561&amp;spn=0.003475,0.008256&amp;num=1&amp;t=h&amp;z=18&amp;layer=c&amp;cbll=47.617752,-122.067561&amp;panoid=0j117WajFze6sY7Y0BX0wg&amp;cbp=12,34,0,18.48">https://maps.google.com/maps?q=47.617732,-122.067532&amp;ll=47.617752,-122.067561&amp;spn=0.003475,0.008256&amp;num=1&amp;t=h&amp;z=18&amp;layer=c&amp;cbll=47.617752,-122.067561&amp;panoid=0j117WajFze6sY7Y0BX0wg&amp;cbp=12,34,0,18.48</a></p>	Elafrance	OPEN	Thomas	Smalius	smalius@gmail.com					Washington	Unknown	Sammamish	crupke	Forwarded to Eric L			Drainage Problems	665 E LK Sammamish Parkway NE							Jun 15 2012 5:03PM
8505	9/14/2012	<p>Description: The drainage ditch that runs in front of my home and north of my home along East Lake Sammamish Pkwy NE is clogged and not draining. This has caused water to back up into my landscaping and driveway. Can you have the ditched cleared of debris so that the water drains?</p> <p>Location: I live at 808 E Lake Sammamish Pkwy NE, Sammamish Wa 98074</p>	Kendelman	OPEN	Steven	Williams	williamsiv@g	7028581187				808 E Lake Sammamish Pkwy	Washington	98074	Sammamish	dlunde			Drainage Problems	E LK Samm Pkwy NE							Sep 14 2012 11:41AM
8642	12/7/2012	<p>Mary says the ditch on either side of the driveway that serves their homes has never been maintained and now that there is a new development across the road whose drainage appears to be funneled to their ditch, it is now overflowing. Please maintain the ditch. Ditch is both north and south of the driveway. The north end has never been maintained. The south end was maintained just barely but not in any meaningful way.</p>	Kendelman	OPEN	Mary	Chatfield		425-868-3034				651 E LK Sammamish Parkw	Washington	Unknown	Sammamish	crupke	Forwarding to Michelle, Kyle, Ho, Martin, & Chun			Drainage Problems	651 ELSP SE						Dec 12 2012 10:58AM

RIGHT OF ENTRY AUTHORIZATION  
King County Parks  
East Lake Sammamish Trail

Signature: Karen Hamilton Jeff Reinhardtsen Date: 3-21-14

Printed Name: Reinhardtsen Jeff & KAREN HAMILTON Parcel Number: 4065100010

Site Address: 2807 East Lake Sammamish Pkwy SE should be 2805

Comments: When we purchased 2805 E. Lk. Sammamish Pkwy SE, a

formally portion of the property at 2807 E. Lk. Sammamish SE was  
included. So the portion bordering the County's EASEMENT  
for trail use should be 2805 E. Lk. Sammamish Pkwy SE on  
both sides of the trail. So I'm not sure if you need  
to access 2807 further up the hill. Having said that, storm runoff  
starts at the top of hill at the road and it is critical that  
it can get to the lake without obstruction as it represents  
a lot of runoff. I currently have a couple of french  
drain locations on the <sup>steep</sup> driveway that run into a 4" line  
under the trail which then lies on the surface ~~down~~ along  
the south edge of the property to the lake. Without this  
flow the clay hillside turns to mush and flooding on the  
trail occurs, and at least on one occasion the quantity  
of water then flooded the east sides of the houses below.  
If you need additional clarity on this, I can make myself  
available to speak with your consultants.

- Jeff  
253-261-4628

also - \* \* \* SAFETY IS A Huge  
ISSUE - please put  
speed bumps at each  
crossway to slow the  
Bikers down - they go fast currently on the gravel, but once  
it's PAVED, they will go faster and also won't be able  
to hear them coming on pavement.

RIGHT OF ENTRY AUTHORIZATION  
King County Parks  
East Lake Sammamish Trail

Signature: E. Chamberlin Date 3/26/14

Printed Name: Chamberlin E Ann Parcel Number: 3125069004

Site Address: 659 East Lake Sammamish Pkwy SE

Comments: CONDITION:

Please do not allow any physical  
modification to be made to my property  
or adjoining property that would  
increase flow of runoff water into  
my private 12" drainage pipe.  
It runs east/west along south  
border of my property.

Please notify me of access  
dates.

RIGHT OF ENTRY AUTHORIZATION  
King County Parks  
East Lake Sammamish Trail

Signature: Bobby W. Witty Date 3-26-14  
Printed Name: Witty Bobby W+Carol J Parcel Number: 0624069037

Site Address: 1219 East Lake Sammamish Shore Ln SE

Comments: \_\_\_\_\_  
\_\_\_\_\_  
\_\_\_\_\_  
\_\_\_\_\_

RIGHT OF ENTRY AUTHORIZATION  
King County Parks  
East Lake Sammamish Trail

Signature:  Date 3-28-14

Printed Name: Christensen Bob & Ann Parcel Number: 0624069029

Site Address: 1309 East Lake Sammamish Shore Ln SE

Comments: \_\_\_\_\_  
\_\_\_\_\_  
\_\_\_\_\_  
\_\_\_\_\_



RIGHT OF ENTRY AUTHORIZATION  
King County Parks  
East Lake Sammamish Trail

Signature: *John H. Mittenthal* Date 3/27/14

Printed Name: Mittenthal John H + Judy A Parcel Number: 0124500040

Site Address: 4233 206th Ave SE

Comments: \_\_\_\_\_  
\_\_\_\_\_  
\_\_\_\_\_  
\_\_\_\_\_  
\_\_\_\_\_

RIGHT OF ENTRY AUTHORIZATION  
King County Parks  
East Lake Sammamish Trail

Signature: *Douglas G Birrell Lori C Birrell* Date *3/30/14*

Printed Name: Birrell Douglas G+Lori C Parcel Number: 0624069024

Site Address: 1317 East Lake Sammamish Shore Ln SE

Comments: \_\_\_\_\_  
\_\_\_\_\_  
\_\_\_\_\_  
\_\_\_\_\_

RIGHT OF ENTRY AUTHORIZATION  
King County Parks  
East Lake Sammamish Trail

Signature: Phyllis Lane Date: \_\_\_\_\_

Printed Name: Lane Phyllis E Parcel Number: 3225069007

Site Address: 247 East Lake Sammamish Pkwy SE

Comments: \_\_\_\_\_  
\_\_\_\_\_  
\_\_\_\_\_  
\_\_\_\_\_



March 19, 2016

Gina Auld  
King County Parks  
201 South Jackson Street, Suite 700  
Seattle, WA

Re: East Lake Sammamish Trail  
South Sammamish Segment  
Trail Survey Work

Dear Ms. Auld

Thank you for your letter of March 2, 2016 regarding the survey work. I would remind you that the County's title to various segments of the ELST, including that portion of the ELST that crosses my property, is subject to litigation in both Washington State District Court and Federal District Court. Until such time as the various Courts have conclusively decided the title issue, any access to the property without my express permission in writing will be considered as trespassing.

I would be pleased to work with the County to discuss potential access for survey purposes. Please contact the undersigned to discuss the terms of such access.



Tracy Neighbors  
3015 E Lake Sammamish Pkwy SE  
Sammamish, WA 98075

## Laura LaBissoniere

---

**To:** Donahue, Kelly  
**Subject:** RE: tree survey letter

**From:** Mike Gallop [<mailto:mikegallop@gmail.com>]  
**Sent:** Wednesday, March 09, 2016 9:52 PM  
**To:** ELST Master Plan  
**Subject:** tree survey letter

Hello,

We recently received this letter. You seem to have the right address, but wrong owner, the property changed hands 2 years ago.

Your letter is ambiguous, you claim you need access to "county owned property". You separately say all trees within 40 feet will be tagged. I'm assuming this is a fault of language and you will not be accessing our property.

In our area, (3100 block SE) ownership of all but a narrow right of way is clear, that former traveled way (the right of way ) of approximately 30' in width is under dispute, (as your own maps indicate) but since it is the active trail it is reasonable to access it.

You do not own the property 40' from the centerline as you seem to imply in the letter. You may not access our property beyond the staked area. Thank you for letting us know you will be collecting data on the trees in the disputed area, we will ensure there is nothing blocking your access to that area.

Sent from [Mailbird](#)



RIGHT OF ENTRY AUTHORIZATION  
King County Parks  
East Lake Sammamish Trail

Signature: Jeffrey Reinhardson Kam Hamilton Date 3/21/16

Printed Name: Jeffrey Reinhardson & Hamilton

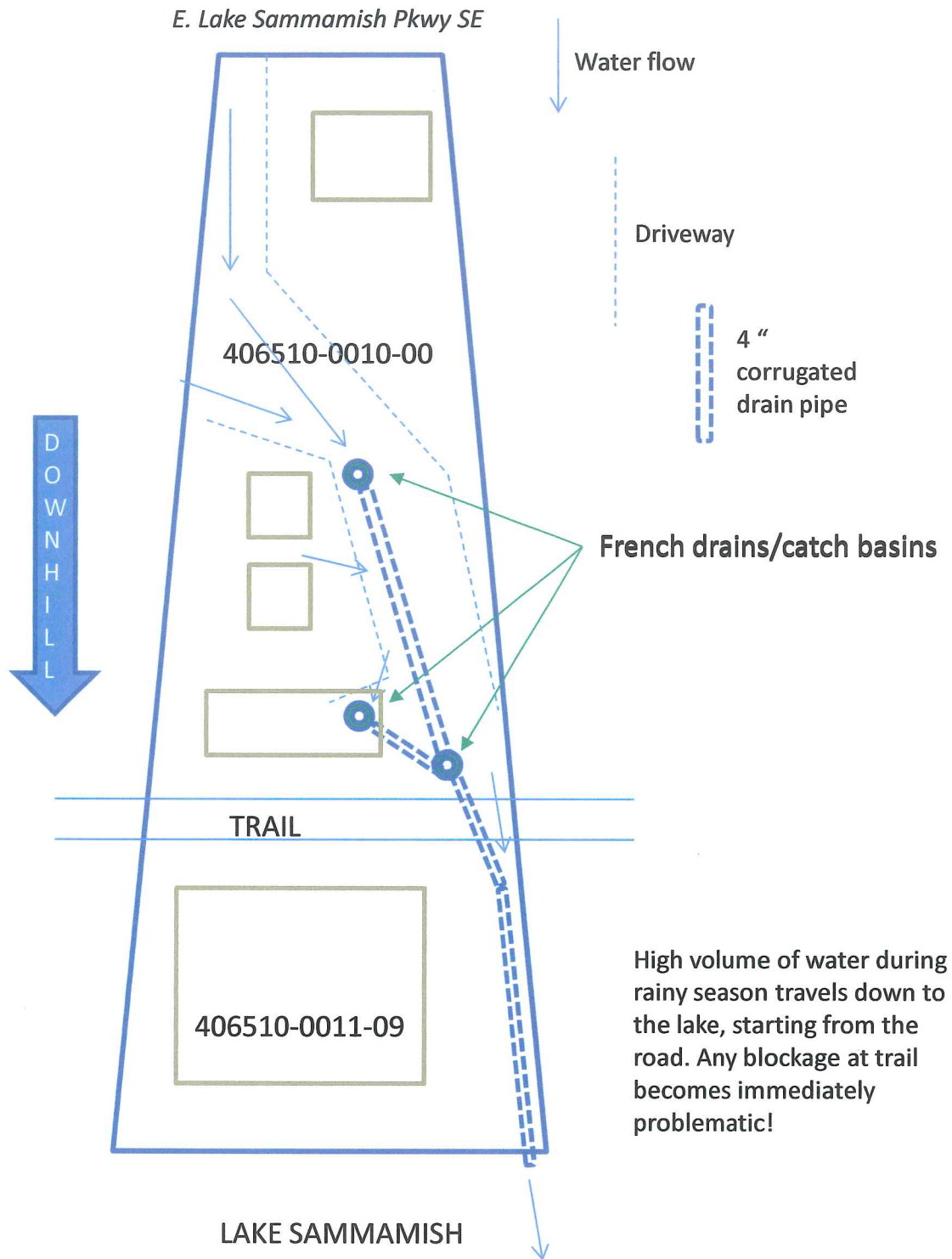
Parcel Number: 406510-0011 AND 406510-0010-00

Site Address: 2805 E Lake Sammamish Pkwy SE 2807 E LAKE SAMMAMISH PKWY SE

Comments: SINCE AT OUR PROPERTIES, THE DRAINAGE SOURCE STARTS AT THE ROAD AND BUILDS DOWNHILL, WE ARE ALSO GRANTING PERMISSION TO ACCESS THE UPPER ADJACENT PROPERTY, AND HAVE INCLUDED A SKETCH OF THE FLOW, DRAINAGE BASINS AND DRAIN PIPE. WITHOUT THIS, THE BANK BECOMES SUPER SATURATED. WE WOULD BE HAPPY TO DISCUSS FURTHER IF NEEDED.  
UNLIKE MOST PROPERTIES ALONG THIS AREA, OUR OWNERSHIP HAS ALREADY BEEN ESTABLISHED IN THE COURTS, AND THE WIDTH AND LOCATION OF THE TRAIL EASEMENT IS LIMITED TO WHAT IS DESCRIBED IN THAT SETTLEMENT.

*Jeffrey Reinhardson*

Reinhardsen/Hamilton Properties  
2805 & 2807 E. Lk. Sammamish Pkwy SE  
Current drainage sketch 3/21/16





← photo of  
lower steps to  
cross trail to  
enter 2805 East  
Lake Sammamish  
Pkwy SE,  
SAMMAMISH, WA  
98075

owners:  
Jeff Reinhardsen  
Karen Hamilton

As you can see, huge amounts of  
run-off come off the plateau,  
and down our hill. We  
had 2 French drains installed  
to help with the run-off...  
But the hill is very fragile  
and will need to be analyzed  
thoroughly. We also had steel  
pipes pounded into the hillside  
to help stabilize



March 21 2016

Gina Auld  
King County Parks  
201 South Jackson Street, Suite 700  
Seattle, WA

Re: East Lake Sammamish Trail  
South Sammamish Segment  
Trail Survey Work

Dear Ms. Auld

Thank you for your letter of March 2, 2016 regarding the survey work for South Sammamish Section B. I want to remind you that the County's title to various segments of the East Lake Sammamish Trail, including that portion of the trail that crosses my property, is still subject to litigation in both Washington State District Court and Federal District Court. Until such time as the various Courts have conclusively decided the title issue, any access to the property without my express permission in writing will be considered as trespassing.

We would be happy to work with the County to discuss potential access for survey purposes. Please contact us to discuss the terms of such access.

*Bill Van de Bogert*  
*Annette McNabb*

William VanDeBogert  
Annette McNabb  
3143 E Lake Sammamish Shore Lane SE  
Sammamish, Washington 98075  
[mcnabbvan@msn.com](mailto:mcnabbvan@msn.com)

March 21, 2016

Gina Auld  
King County Parks  
201 South Jackson Street, Suite 700  
Seattle, WA

Re: East Lake Sammamish Trail  
South Sammamish Segment  
Trail Survey Work

Parcel No: 3125069004  
Site Address: 659 E Lake Sammamish Pkwy SE

Dear Ms. Auld

Thank you for your letter of March 2, 2016 regarding the survey work. I would remind you that the County's title to various segments of the ELST, including that portion of the ELST that crosses my property, is subject to litigation in both Washington State District Court and Federal District Court. Until such time as the various Courts have conclusively decided the title issue, any access to the property without my express permission in writing will be considered as trespassing.

I would be pleased to work with the County to discuss potential access for survey purposes. Please contact the undersigned to discuss the terms of such access.



Frank J. Marshall  
Mailing address: 16541 Redmond Way #287C, Redmond WA 98052  
Email: frank@timark.net

RIGHT OF ENTRY AUTHORIZATION  
King County Parks  
East Lake Sammamish Trail

Signature: \_\_\_\_\_ Date \_\_\_\_\_

Printed Name: Howard and Colleen Buck

Parcel Number: 724069039

Site Address: 3125 E Lake Sammamish Shore Ln SE

Comments: NO - do not trespass  
on our property

*Colleen Buck*



RIGHT OF ENTRY AUTHORIZATION  
King County Parks  
East Lake Sammamish Trail

Signature: \_\_\_\_\_ Date \_\_\_\_\_

Printed Name: Howard and Colleen Buck

Parcel Number: 724069039

Site Address: 3125 E Lake Sammamish Shore Ln SE

Comments: \_\_\_\_\_  
\_\_\_\_\_ NO \_\_\_\_\_  
\_\_\_\_\_ Colleen Buck \_\_\_\_\_  
\_\_\_\_\_  
\_\_\_\_\_

March 25, 2016

Gina Auld  
King County Parks  
201 South Jackson Street, Suite 700  
Seattle, WA

Re: East Lake Sammamish Trail  
South Sammamish Segment  
Trail Survey Work

Dear Ms. Auld

Thank you for your letter of March 2, 2016 regarding the survey work. I would remind you that the County's title to various segments of the ELST, including that portion of the ELST that crosses my property, is subject to litigation in both Washington State District Court and Federal District Court. Until such time as the various Courts have conclusively decided the title issue, any access to the property without my express permission in writing will be considered as trespassing.

I would be pleased to work with the County to discuss potential access for survey purposes. Please contact the undersigned to discuss the terms of such access.

Shawn Huarte  
3003 E LK Samm. PKWY SE  
Sammamish, WA 98075

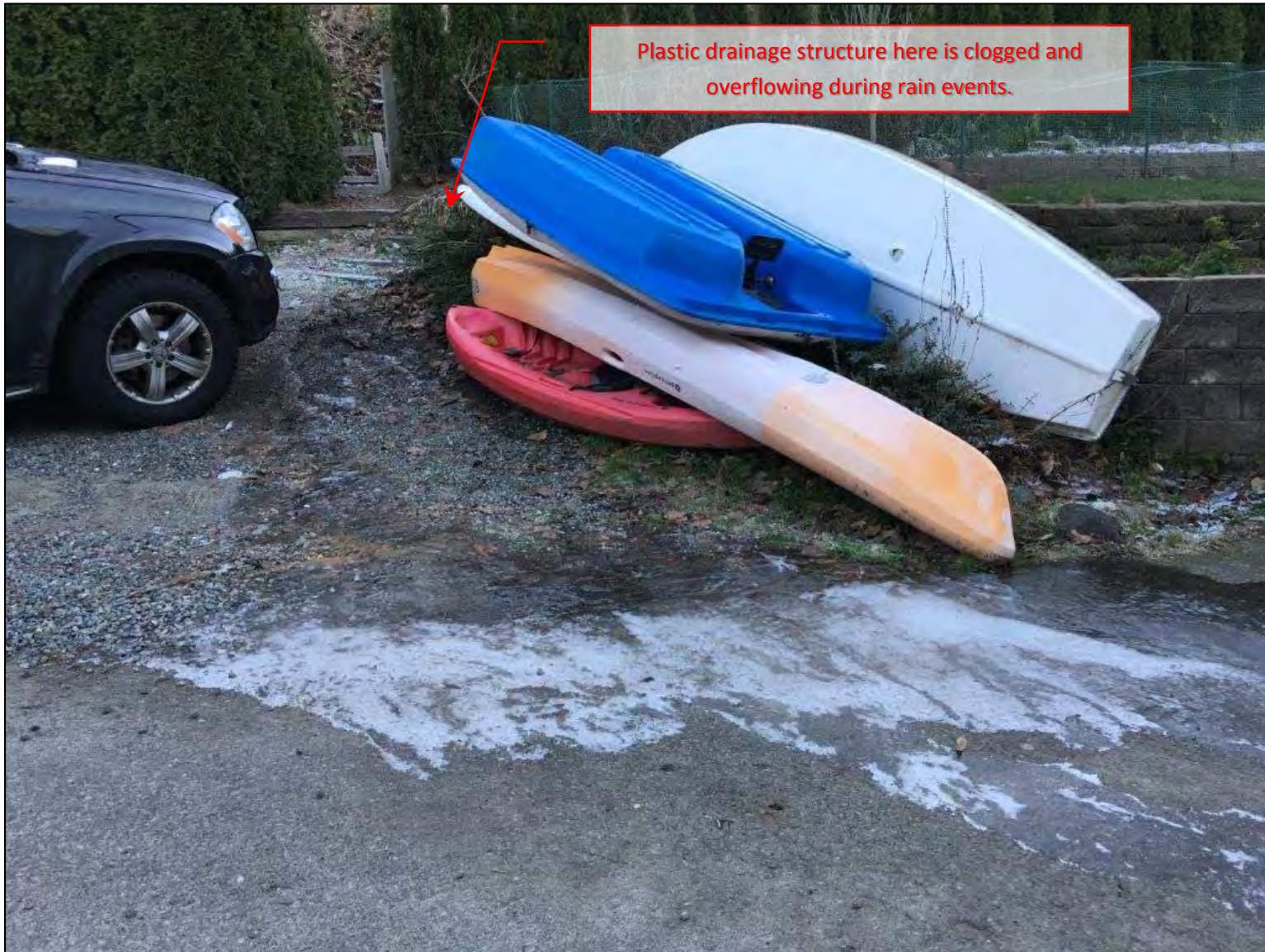
**From:** Russ Albright [russa@crosslaketech.com]  
**Sent:** Friday, March 11, 2016 2:20 PM  
**To:** ELST Master Plan; [judi.albright@gmail.com](mailto:judi.albright@gmail.com)  
**Subject:** RE: Notice of Entry\_Albright

Hi- no we do not have a fence or hedge on king county property or that blocks access to king county property. The only fence is a installed by king county or hedge row that has not been maintained by king county

You do not have permission to cross our property or even the need to cross our property, if that is what you are asking for?

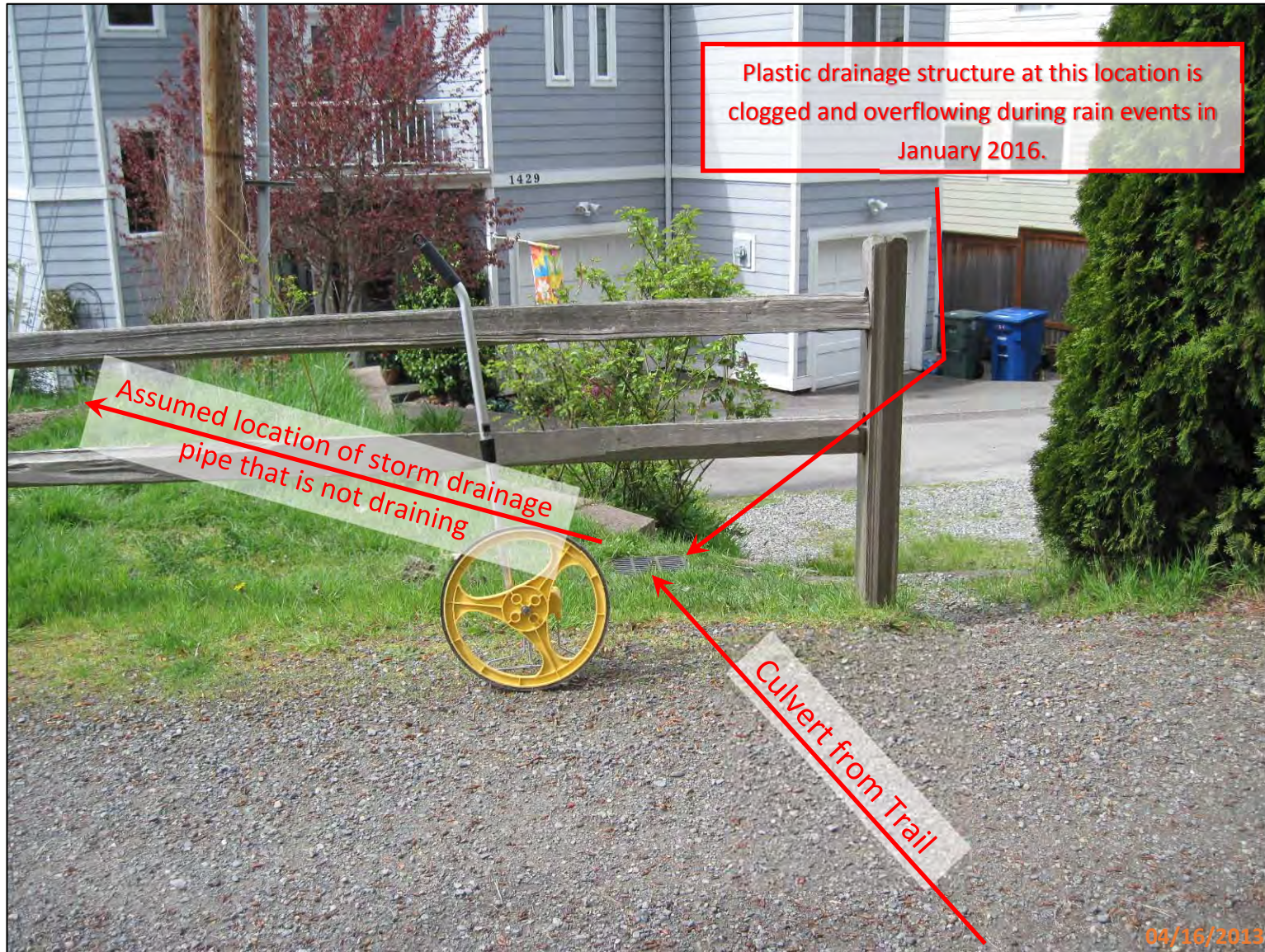
Too many instances looking out our back window with someone claiming to be king county representatives walking around our house?





Picture 1 – This picture was submitted by Mr. Nick Tsilas in the initial drainage complaint email dated 1-4-2016. It appears this water is coming from the plastic catch basin near a recently installed row of arborvitaes. The plastic catch basin structure accepts water from the ELST Trail drainage ditch on the east side of the trail. (Looking east)





Picture 2 – This picture shows the plastic catch basin drainage structure in 2013 prior to installation of the arborvitae shown in picture 1 and 3. This structure is not draining in 2016. (Looking west)





Picture 3 – This picture shows the clogged plastic structure. Picture 4 shows the inside of this structure. The southern row of arborvitae in the direct vicinity of this structure were installed after the pictures taken in 2013. (Looking southwest)





Picture 4 – This picture shows the plastic structure from Pictures 1, 2, and 3. This structure is not draining and appears to be clogged. This structure would overflow during heavy rain events if the outlet pipe is clogged. In this picture, the water is almost to the rim of the structure and does not appear to be draining. (Looking downward facing south)





Picture 5 – This picture shows the assumed orientation of the underground drainage pipe as it connects between the two nearby drainage structures.





Picture 6 – This picture shows the inside of the storm drainage basin/concrete drainage box in front of the home at 1429. This CB could be clogged and is assumed to take the water from the trail ditch to the lake. This small corrugated black pipe shown in this picture is unknown and is likely the outlet for the structure that is overflowing.





Picture 7 – This picture shows the clogged drainage ditch on the ELST Trail. There is a PVC Culvert that drains this ditch that could not be found during the site visit. It is assumed that the drainage pipe could be clogged.





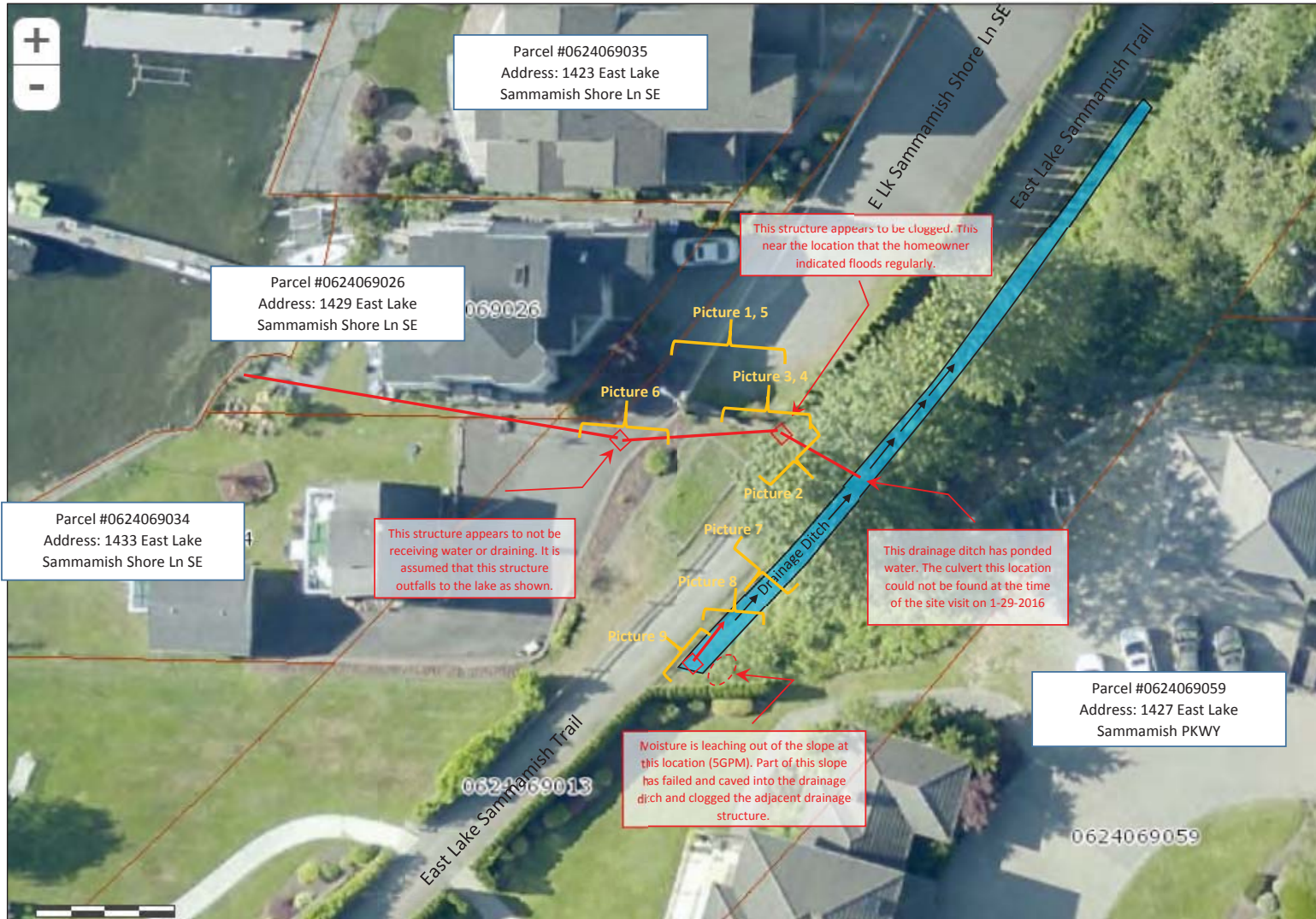
Picture 8 – This picture shows a 12-inch ADS pipe that is inside the ELST Drainage ditch at the edge of the trail. This pipe is completely clogged and appears to connect directly to a drainage catch basin.





Picture 9 – This picture shows a clogged structure that connects to the 12-inch ADS pipe in the drainage ditch on the ELST trail. The slope adjacent and directly east of this structure has failed and clogged the ditch. There is also a minor amount of water leaching out/bubbling up out of the ground at this location. Note: There is also a 1-1/2 diameter PVC pipe sticking up vertically in the structure. This pipe is unknown.









Picture 1 – This picture shows the drainage ditch on the east side of the East Lake Sammamish Trail. In this picture there is a clogged structure and a clogged 12-inch ADS pipe. This location was cleaned out with a vactor truck at a later time and subsequently viewed with a pipe camera. See picture 2 to see this location after the system was cleaned out. (Looking south on the trail adjacent to 1428 E Lake Samm Shore Ln SE)





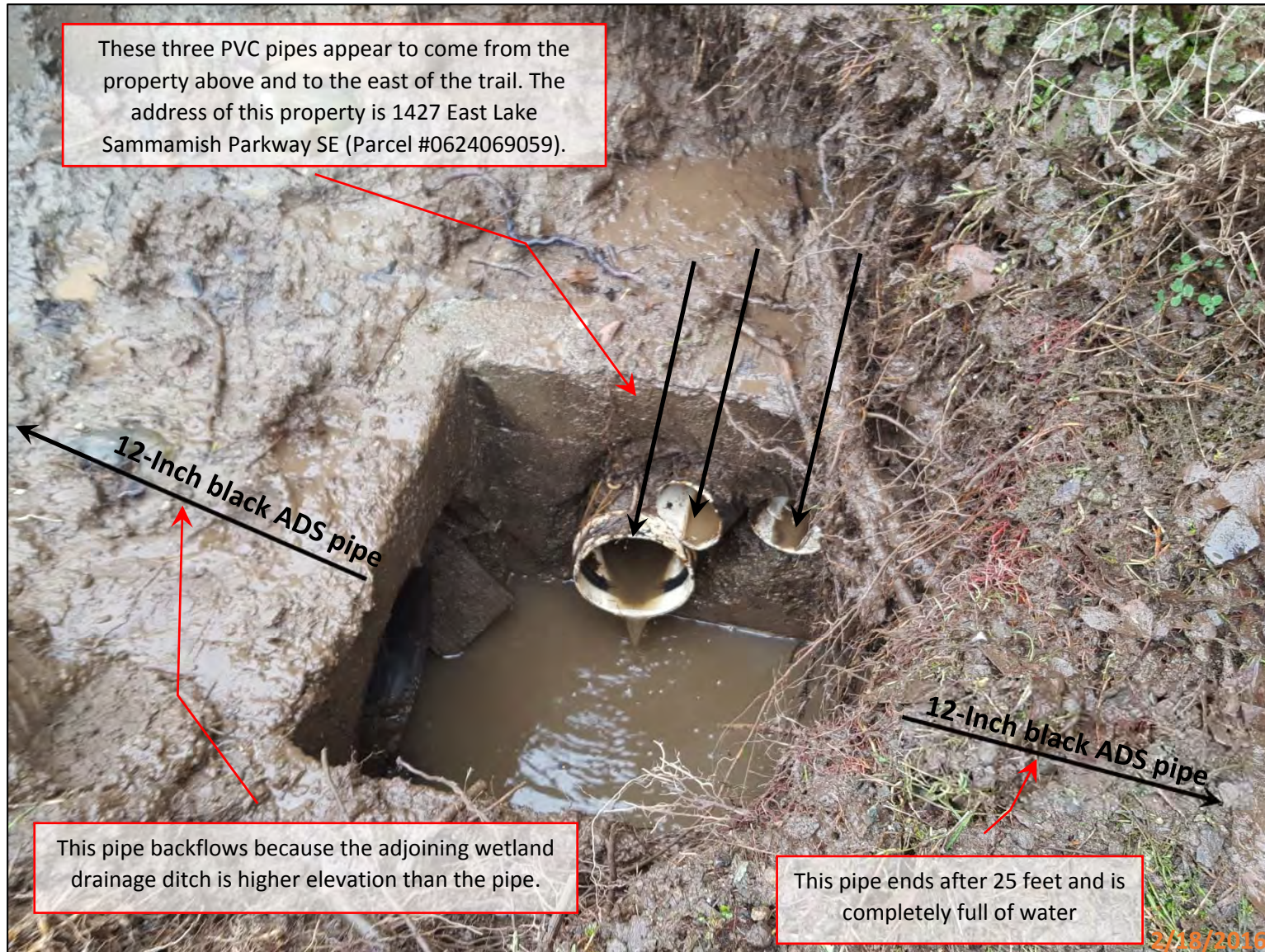
Picture 2 - This picture shows the drainage system from Picture 1 after it was cleared out with a vactor truck. This pipe is lower than the ditch which causes it to backflow. (Looking south on the trail adjacent to 1428 E Lake Samm Shore Ln SE)





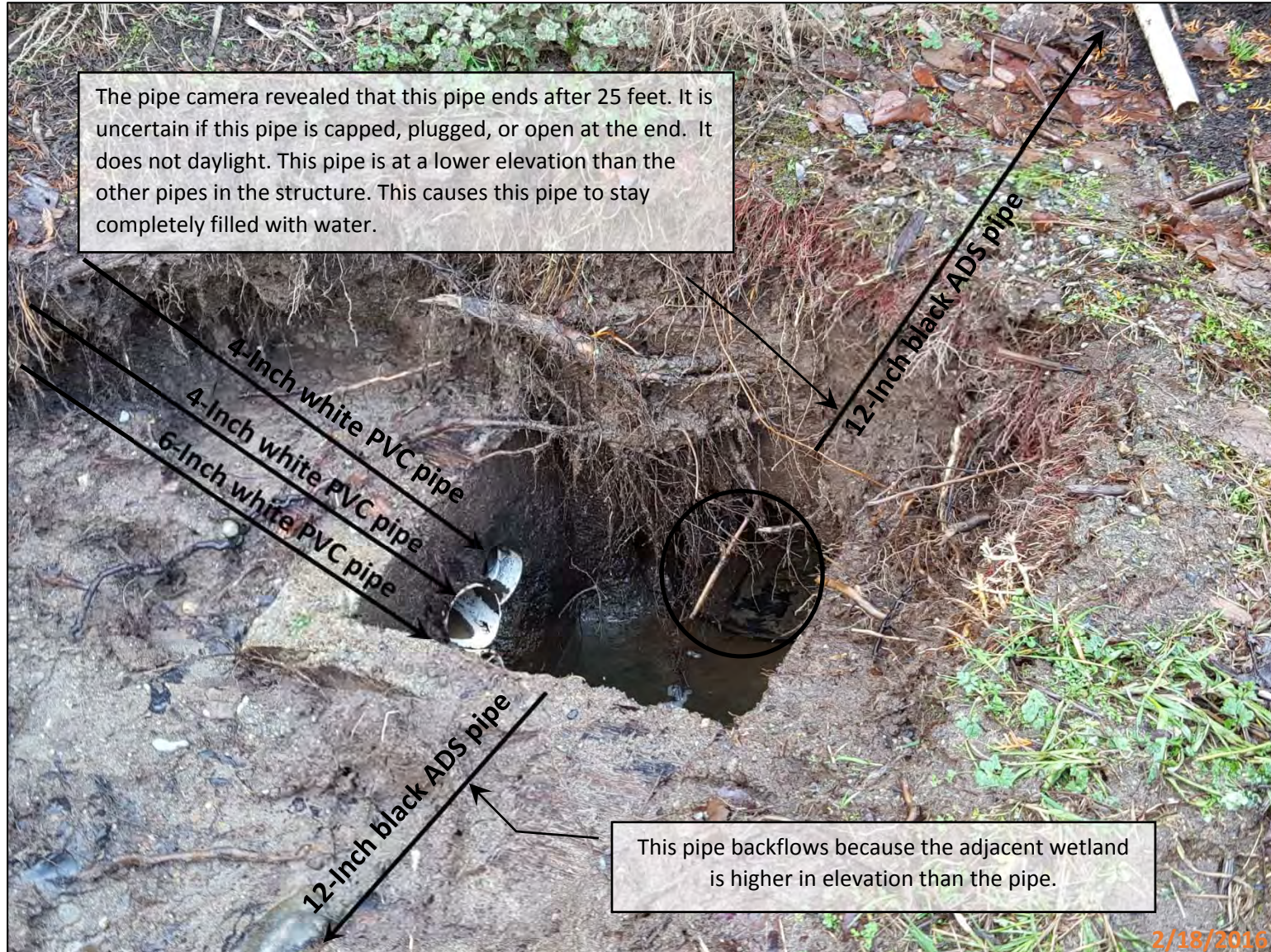
Picture 3 – This picture shows the clogged drainage structure in the trail drainage ditch adjacent to 1428 E lake Sammamish Shore Ln Se. (Looking downward and to the east)





Picture 4 - This picture shows the drainage structure from Picture 3 after it was cleaned out with a vector truck. The large white pipe on the left is a 6-inch PVC pipe and the other two white pipes are 4-inch PVC pipes. There are also two 12-inch diameter black corrugated ADS pipes that connect to this structure. This structure does not have a lid. None of the pipes observed in this structure appear to have been tightly grouted at the opening in which they enter the concrete structure. This is common construction practice.





Picture 5 - This picture shows the drainage structure from Picture 3 after it was cleaned out with a vector truck. The two 12-inch ADS pipes are not draining in the correct direction. The pipe on the right side of the picture ends after 25-feet resulting in the pipe being filled with water.





Picture 6 – This picture shows the drainage ditch/wetland approximately 20-to-30 feet north of the drainage system shown in pictures 1-5. This ditch water backflows into the drainage system because the ADS pipe shown in Picture 1 and 2 is lower in elevation than the drainage ditch. There is also an 8-inch PVC pipe that travels beneath the trail and connects to a yard drain in front of 1428 E Lake Samm Shore Ln SE (shown in red). See Picture 7-10 for more information on this drainage pipe. (Looking north)





Picture 7 – This 8-inch PVC pipe travels west from the drainage ditch and enters a yard drain in front of 1428 E Lake Sammamish Ln SE. (Looking north)





Picture 8 - This 8-inch PVC pipe travels west from the trail drainage ditch and enters a yard drain in front of 1428 E Lake Samm Shore Ln SE. This yard drain was filled to the rim with water prior to the vactor truck cleaning the structure out. This is the location that appears to overflow onto the adjacent private roadway in heavy rain events. This area received a complaint from the Tsilas Residence on 1/19/2016.





Picture 9 - This picture shows the yard drain prior to the vacor truck cleaning it out. This is the location that appears to overflow in heavy rain events. Onto East Lake Sammamish Shore Lane SE. This area received a complaint from the Tsilas Residence on 1/19/2016. The water in the yard drain appears to be at least 12-inches above the crown of the 4-inch ADS outlet pipe. The pipe does not appear to be draining. The orientation of the 4-inch ADS line is unknown.





Picture 10 - This picture shows the yard drain after to the vactor truck cleaned it out. The 8-inch PVC pipe shown comes from the ELST trail drainage ditch. The 4-inch ADS pipe appears to be connects to a nearby homeowner drainage system to the east on East Lake Sammamish Shore Ln SE. The 4-inch ADS pipe was not cleared out or viewed with a pipe camera. This yard drain was completely filled with water to the rim of the structure prior to cleaning it out. See picture 9 to view this structure prior to it being cleaned out.



## Magnified Image







DRAFT



Picture 1 – This picture shows the outfall from the west side of the ELST Trail. This outfall drains Jurisdictional Ditch #16. After entering the catch basin shown the water enters the catch basins shown in this photolog through a 6-inch PVC pipe and ultimately enters Lake Sammamish. (Looking east from East Lake Sammamish Shore Ln NE)



DRAFT



Picture 2 – This picture shows another catch basin on East Lake Sammamish Shore Ln NE. On the right side of the picture you can see a large amount of run-off from the East Lake Sammamish Shore Ln NE. This is the same catch basin shown in picture 1. (Looking south from East Lake Sammamish Shore Ln NE)





DRAFT



Picture 3 – This picture shows another catch basin on East Lake Sammamish Shore Ln NE. (Looking south from East Lake Sammamish Shore Ln NE)





Picture 4 – Looking downward at the catch basin from Picture 3 on East Lake Sammamish Shore Ln NE. The water continues through the 6-inch PVC pipe. The black pipe on the top of the picture is a 4-inch ADS pipe that appears to come from the rockery to the east. (Looking downward and facing east from East Lake Sammamish Shore Ln)



DRAFT



Picture 5 – This picture shows the 6-inch pipe continuing to the lake adjacent to house #439. This picture also shows the downspouts of the house entering a washed rock trench against the home exterior walls. The homeowner indicated water was coming up out of this washed rock trench closer to the lake. (Looking west towards the lake near 439 East Lake Sammamish Ln NE) \*The exact location of the 6-inch PVC line in respect to home #425 and 439 and the structure at the lake is assumed to be in this location.



DRAFT



Picture 6 – This picture shows the 6-inch pipe continuing to the catch basin/concrete box at the lake adjacent to the boat launch at house #439. During our visit the box was flowing out of the grate from the top and flowing down the boat launch. The connected 6-inch pipe was under over 8-inches of water. (Looking east towards home #439) \*The exact location of the 6-inch PVC line in respect to home #425 and 439 and the structure at the lake is assumed to be in this location.





DRAFT



Picture 7 – This picture shows the catch basin/concrete box at the lake adjacent to the boat launch at house #439. During our visit the box was flowing out of the grate from the top and flowing down the boat launch. The connected 6-inch pipe was under over 8-inches of water.





DRAFT



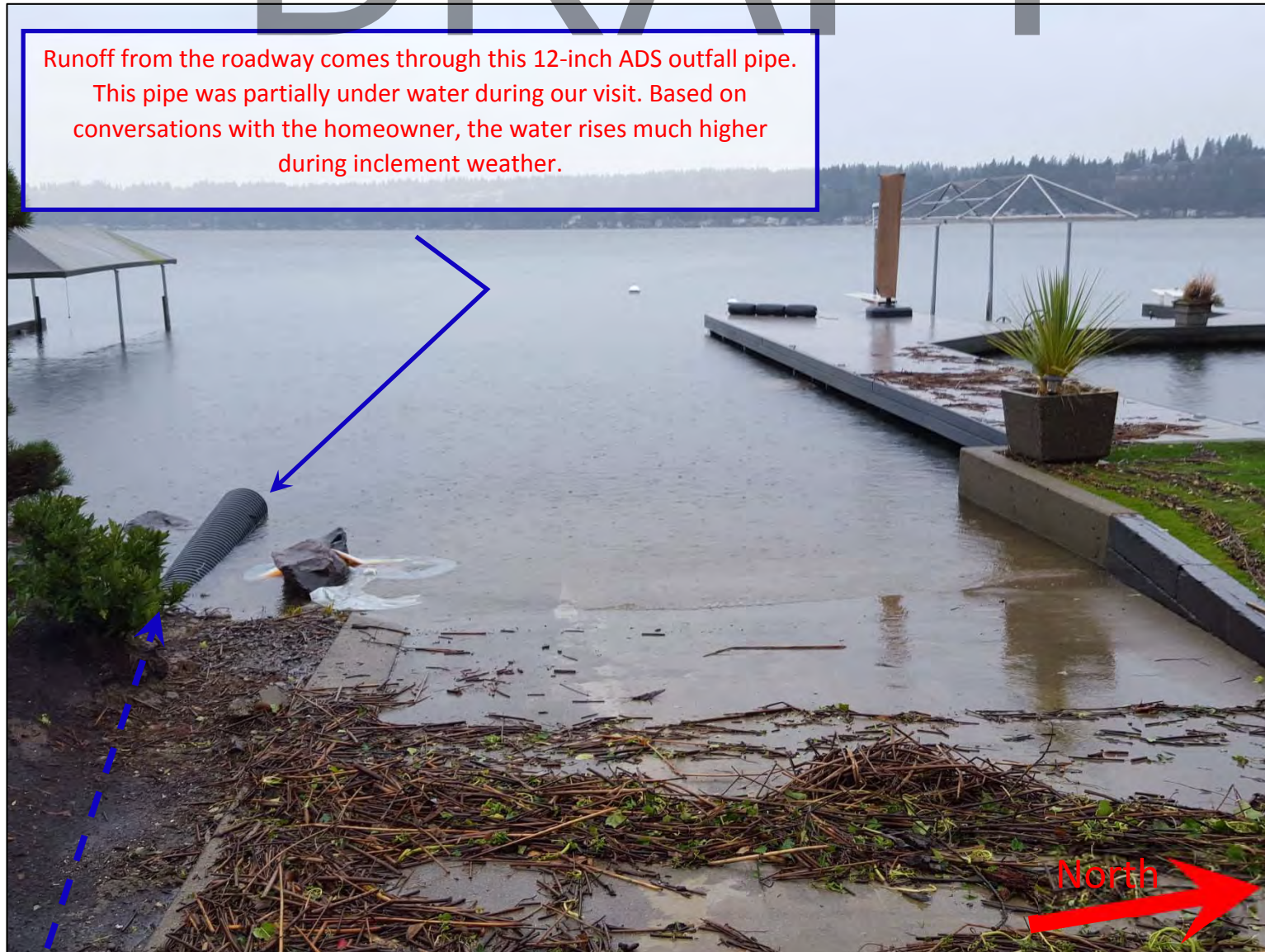
Picture 8 – This picture shows the catch basin/concrete box at the lake adjacent to the boat launch at house #439. During our visit the box was flowing out of the grate from the top and flowing down the boat launch. The connected 6-inch pipe was under over 8-inches of water.



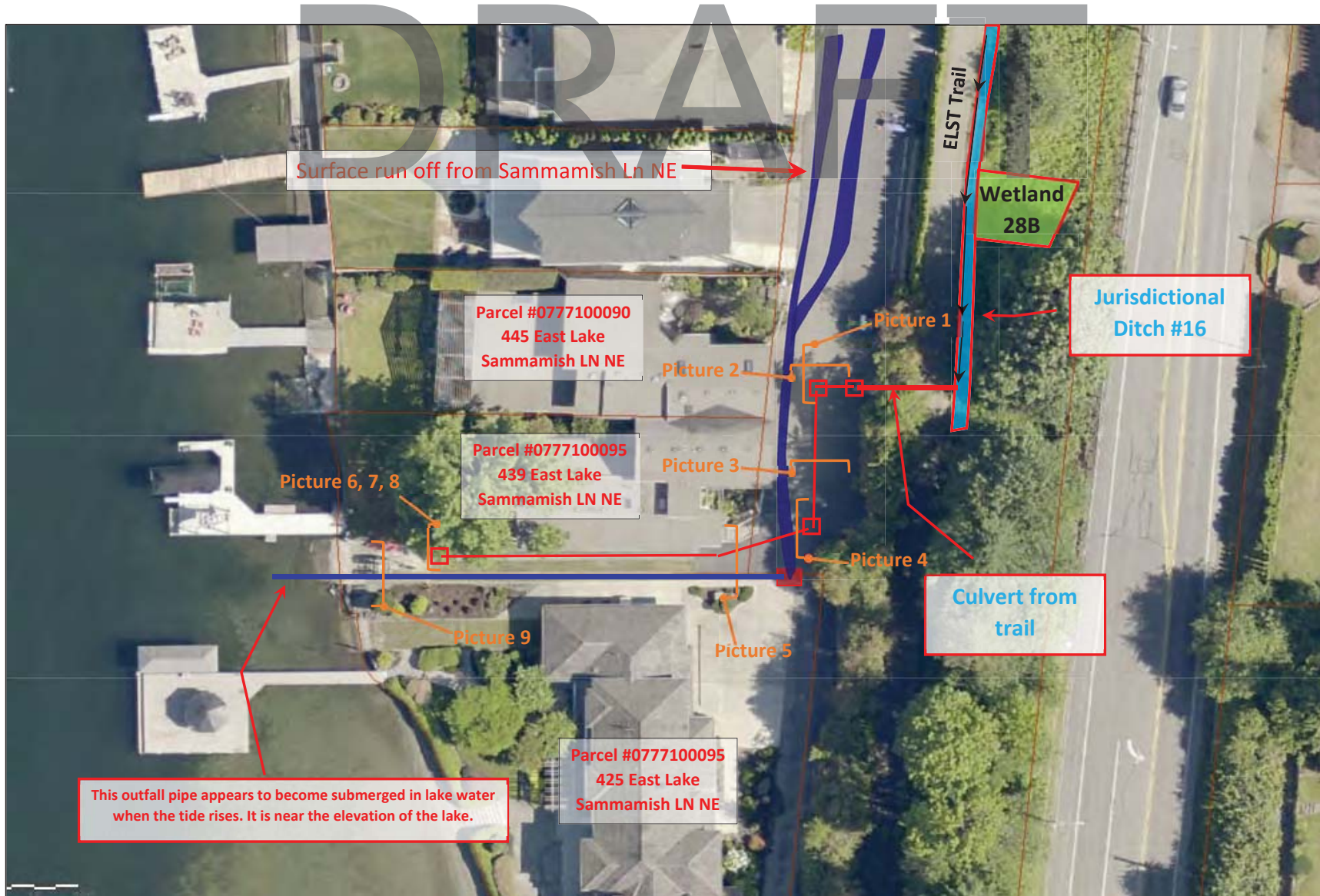


DRAFT

Runoff from the roadway comes through this 12-inch ADS outfall pipe. This pipe was partially under water during our visit. Based on conversations with the homeowner, the water rises much higher during inclement weather.

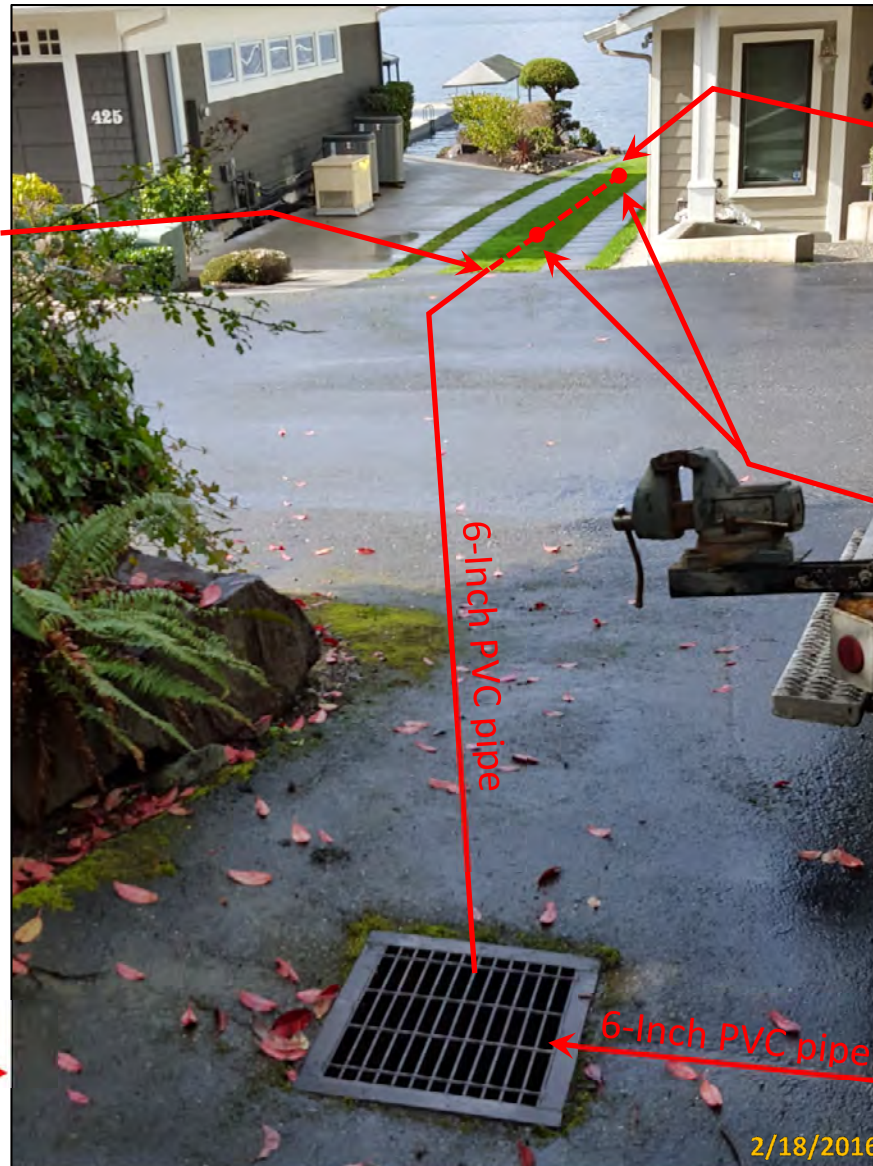


Picture 9 – This picture shows the 12-inch ADS that connects to a catch basin unrelated to this line. This ADS pipe captures a large amount of runoff from the East Lake Sammamish Shore Ln NE. It appears to be at a low elevation which could cause this pipe to become submerged when the tide rises. It was noticed that the front of the pipe appears to have been propped up with rocks.





The PVC Pipe is crushed at the piping joint at this location. The pipe transitions to a 6-inch PVC perforated pipe.

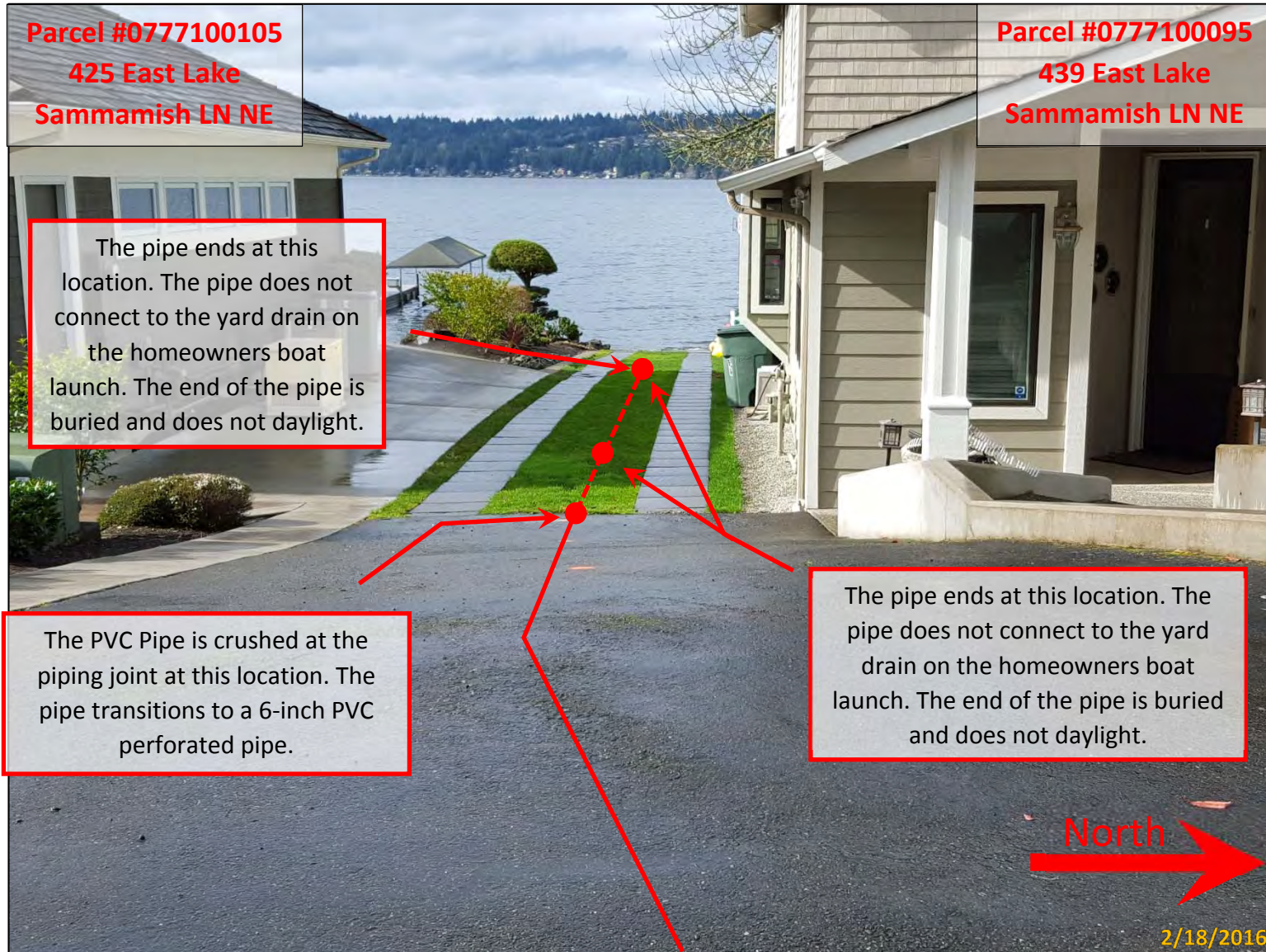


The pipe ends at this location. The pipe does not connect to the yard drain on the homeowners boat launch. The end of the pipe is buried and does not daylight.

The pipe ends at this location. The pipe does not connect to the yard drain on the homeowners boat launch. The end of the pipe is buried and does not daylight.

Picture 1 – This picture shows the 6-inch PVC pipe that was TVed with a camera. The 6-inch PVC pipe shown in this picture is a solid wall white PVC pipe until the pipe reaches the homeowner’s grass. At the grass, the pipe transitions to a 6-inch perforated PVC drain pipe. (Looking west from East Lake Sammamish Shore Ln NE)





Picture 2 – This picture shows the 6-inch PVC pipe that was TVEd with a camera. The 6-inch PVC pipe shown in this picture is a solid wall white PVC pipe until the pipe reaches the homeowner’s grass. At the grass, the pipe transitions to a 6-inch perforated PVC drain pipe. (Looking west between parcels 0777100095 and 0777100105)



**Parcel #0777100095**  
**439 East Lake**  
**Sammamish LN NE**

**Parcel #0777100105**  
**425 East Lake**  
**Sammamish LN NE**

The PVC Pipe is crushed at the piping joint at this location. The pipe transitions to a 6-inch perforated PVC pipe.

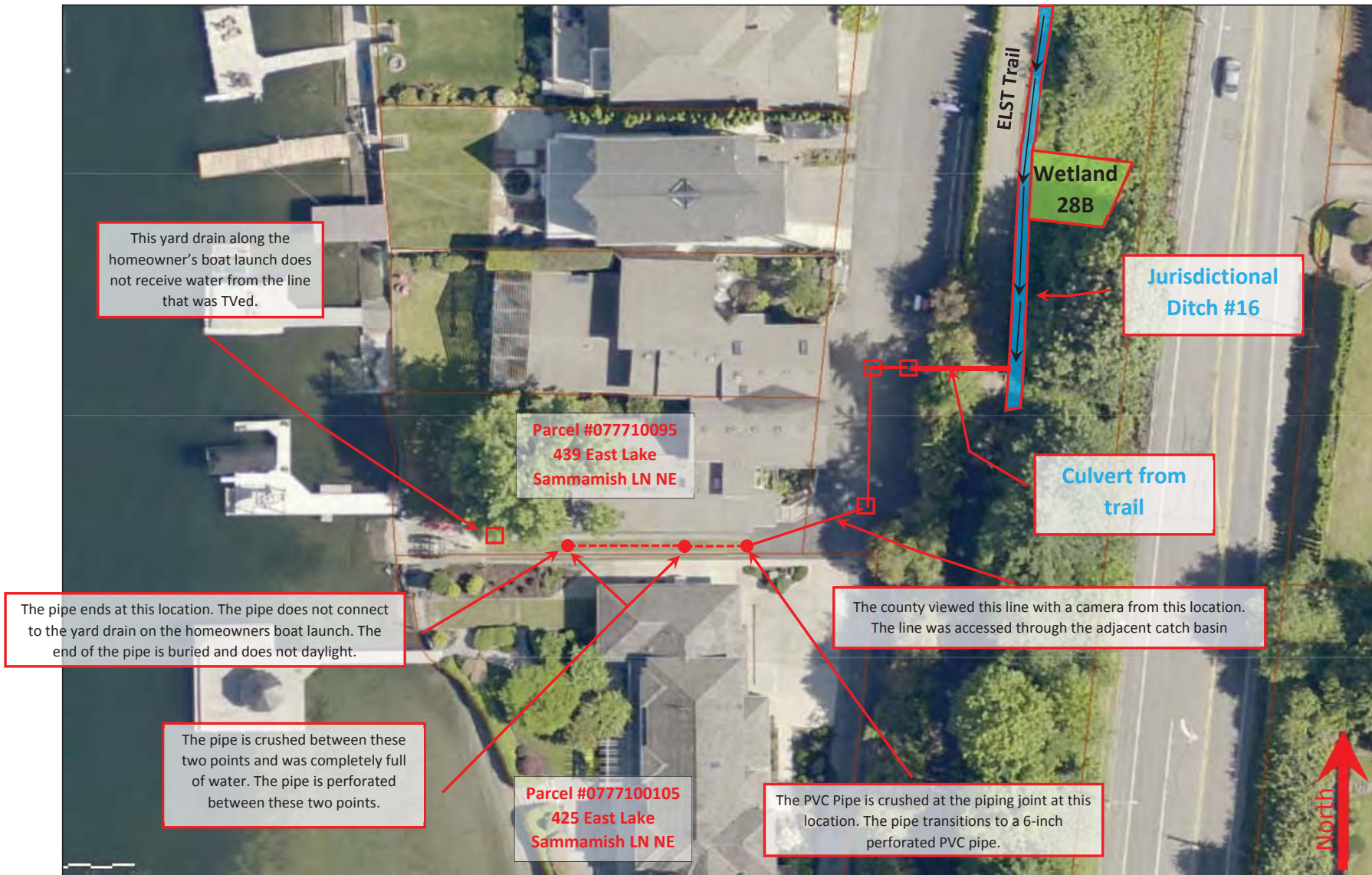
The pipe ends at this location. The pipe does not connect to the yard drain on the homeowners boat launch. The end of the pipe is buried and does not daylight.

The pipe is crushed between these two points and was completely full of water. The pipe is perforated between these two points.



Picture 3 – This picture shows the location that this pipe terminates in the grassy area between the two parcels. The pipe transitions to a perforated PVC pipe at the start of the homeowner’s grass. The pipe ends at the location shown and does not daylight out of the ground. (Looking east between parcels 0777100095 and 0777100105)









Picture 1 – This 12-inch pipe was viewed with a pipe camera. This pipe is shown in orange spray paint and connects to the Wetland at this location. (Looking north)





Picture 2 - The pipe changes from a 12-inch concrete pipe to a 6-inch ADS pipe. (Looking downward and northeast)





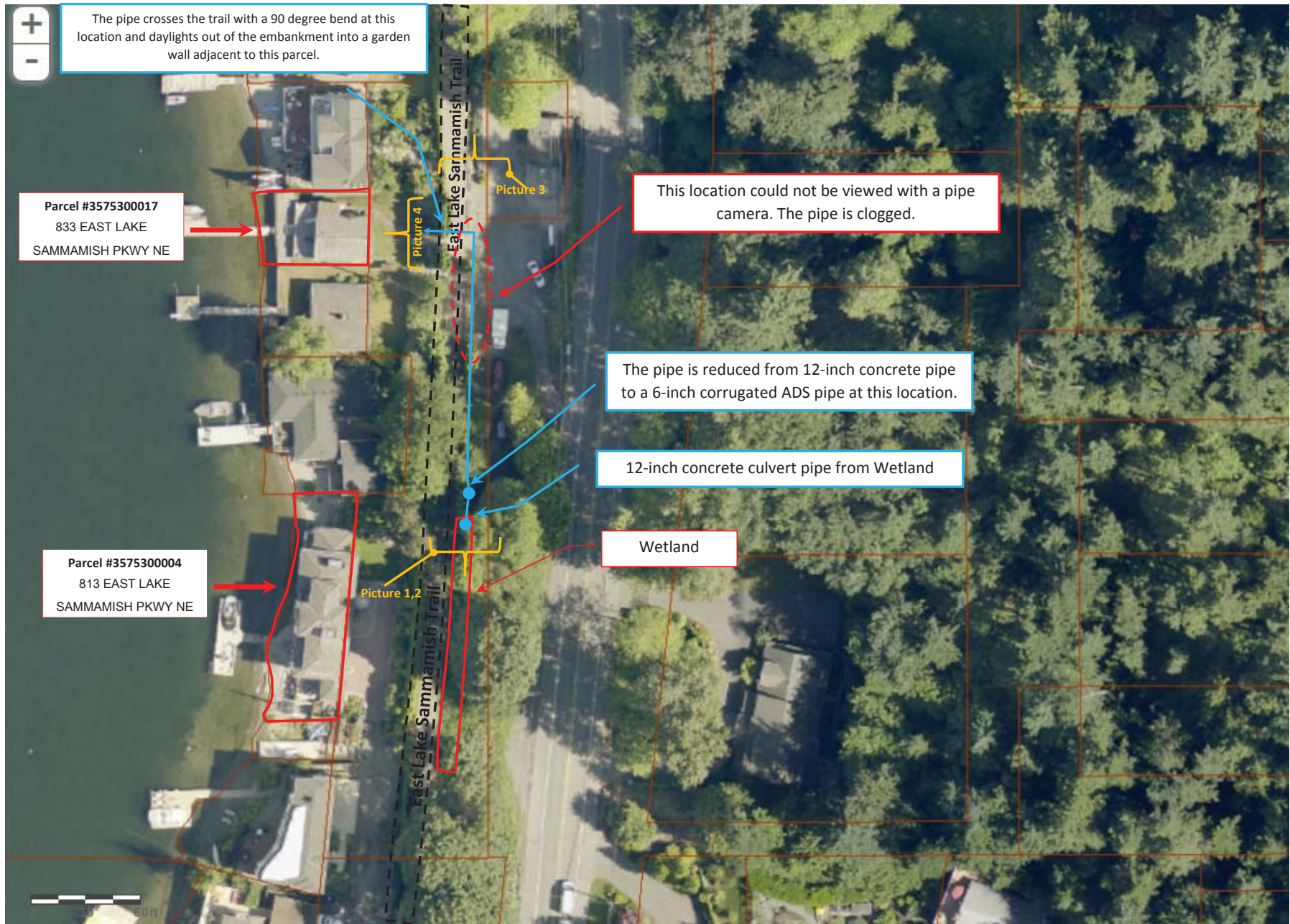
Picture 3 – Looking south towards the drainage line from Picture 1 and 2 (shown as blue line). The line takes a sudden 90 degree turn towards the lake. This picture was taken approximately 250 feet north of the beginning of the 12-inch concrete pipe from Picture 1. (Looking south)





Picture 4 – Approximately 20' feet from the 90 degree bend on the east side of the trail, the pipe daylights out of the wood garden wall at 833 East Lake Sammamish Parkway NE. (Looking southeast)











Picture 1 – This photo shows the clogged 24-inch corrugated metal pipe in front of the Hill residence. (Looking south)





Picture 2 - This photo shows the ponding water in the wetland directly in front of Mr. Hill's property. This wetland is on the east side of the trail and cannot drain due to the clogged pipe shown in picture 1. (Looking south)





Picture 3 – Concrete stairs directly south of the clogged corrugated metal pipe. The pipe appears to travel southward under these stairs and towards the concrete rubble wall (Looking North)





Picture 4 – The pipe continues to the south and appears to potentially travel under the concrete rubble wall. (Looking North)







## Appendix C

Hydrologic and Hydraulic Calculations

C1 – Detailed Land Use

C2 – WWHM2012 Outputs

C3 – Hydraulic Calculations for Stream Culverts

C4 – Conveyance Calculations

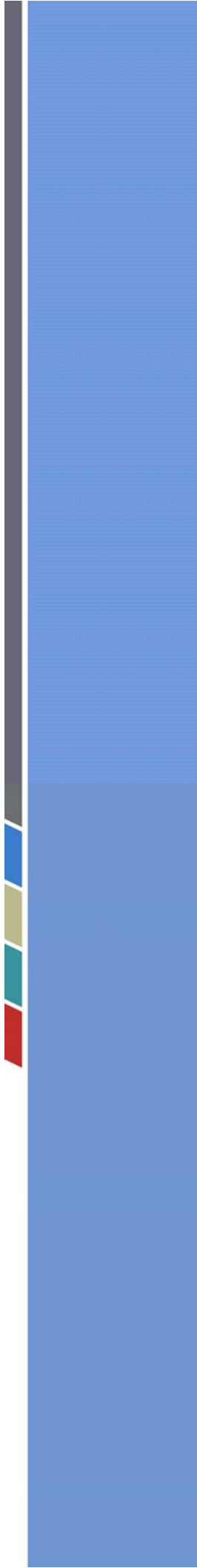
DRAFT







## C1 – Detailed Land Use





Detailed Land Use Calculations for Target Impervious Surfaces

ELST South Sammamish Segment B - Begin STA 282+75 and END STA 472+25

Lake Sammamish is a flow control exempt water body.

BEGIN SEGMENT B		Soils		Use FCBMPS and Apply Land Use Credits	
BEGIN B-LINE					
<b>TDA 10</b>					
STA Begin	STA End	Trail width (ft)	Trail area (sq-ft)	Impervious area (acre)	OUTWASH
283+25	287+75	16	7,200	0.17	No FC
<b>TDA 11</b>					
STA Begin	STA End	Trail width (ft)	Trail area (sq-ft)	Impervious area (acre)	OUTWASH
287+75	289+50	16	2,800	0.06	standard
289+50	291+50	18.25	3,650	0.08	wall
291+50	292+25	16	1,200	0.03	standard
292+25	293+65	18.25	2,555	0.06	wall
293+65	295+00	16	2,160	0.05	standard
295+00	295+85	18.25	1,551	0.04	wall
Total			13,916	0.32	Flow Control Required
<b>TDA 12</b>					
STA Begin	STA End	Trail width (ft)	Trail area (sq-ft)	Impervious area (acre)	TILL
295+85	297+75	18.25	3,468	0.08	wall
297+75	298+18	19.25	828	0.02	wall and 3' shoulder
298+18	298+40	17	374	0.01	3' shoulder
298+40	298+85	16	720	0.02	driveway
298+85	299+00	18.25	274	0.01	wall
299+00	299+50	19.25	963	0.02	wall and 3' shoulder
299+50	300+25	17	1,275	0.03	3' shoulder
Total			7,901	0.18	No FC
<b>TDA 13</b>					
STA Begin	STA End	Trail width (ft)	Trail area (sq-ft)	Impervious area (acre)	TILL
300+25	300+90	17	1,105	0.03	3' shoulder
300+90	302+65	18.25	3,194	0.07	wall
302+65	304+65	16	3,200	0.07	standard
Total			7,499	0.17	No FC
<b>TDA 14</b>					
STA Begin	STA End	Trail width (ft)	Trail area (sq-ft)	Impervious area (acre)	TILL
304+65	305+55	16	1,440	0.03	driveway
305+55	305+84	17	493	0.01	3' shoulder
305+84	308+13	18.25	4,179	0.10	wall
308+13	308+25	26.5	318	0.01	trail + rest area
Total			6,430	0.15	No FC
<b>TDA 15</b>					
STA Begin	STA End	Trail width (ft)	Trail area (sq-ft)	Impervious area (acre)	TILL
308+25	308+35	26.5	265	0.01	trail + rest area
308+35	309+25	16	1,440	0.03	standard
Total			1,705	0.04	No FC
<b>TDA 16</b>					
STA Begin	STA End	Trail width (ft)	Trail area (sq-ft)	Impervious area (acre)	TILL
309+25	310+70	16	2,320	0.05	standard
310+70	311+00	18.25	548	0.01	wall
Total			2,868	0.07	No FC
<b>TDA 17</b>					
STA Begin	STA End	Trail width (ft)	Trail area (sq-ft)	Impervious area (acre)	TILL
311+00	311+75	20.5	1,538	0.04	wall both sides
311+75	312+90	18.25	2,099	0.05	wall
Total			3,636	0.08	No FC
<b>TDA 18</b>					
STA Begin	STA End	Trail width (ft)	Trail area (sq-ft)	Impervious area (acre)	TILL
312+90	314+00	18.25	2,008	0.05	wall
Total			2,008	0.05	No FC
<b>TDA 19</b>					
STA Begin	STA End	Trail width (ft)	Trail area (sq-ft)	Impervious area (acre)	TILL
314+00	314+95	18.25	1,734	0.04	wall
314+95	316+40	19.25	2,791	0.06	wall + 3' shoulder
Total			4,525	0.10	No FC
<b>TDA 20</b>					
STA Begin	STA End	Trail width (ft)	Trail area (sq-ft)	Impervious area (acre)	TILL
316+40	319+70	19.25	6,353	0.15	wall + 3' shoulder
319+70	320+32	18	1,116	0.03	3' shoulder both sides
320+32	320+65	16	528	0.01	driveway
320+65	323+90	17	5,525	0.13	3' shoulder
Total			13,522	0.31	Flow Control Required
<b>TDA 21</b>					
STA Begin	STA End	Trail width (ft)	Trail area (sq-ft)	Impervious area (acre)	TILL
323+90	325+77	17	3,179	0.07	3' shoulder
325+77	325+97	16	320	0.01	driveway
325+97	326+15	17	306	0.01	3' shoulder
326+15	327+14	19.25	1,906	0.04	wall + 3' shoulder
327+14	327+24	17	170	0.00	3' shoulder
327+24	327+90	16	1,056	0.02	standard
327+90	328+11	23.5	494	0.01	trail + rest area
328+11	328+26	18.25	274	0.01	wall
Total			7,704	0.18	Flow Control Required
<b>TDA 22</b>					
STA Begin	STA End	Trail width (ft)	Trail area (sq-ft)	Impervious area (acre)	OUTWASH
328+26	333+64	18.25	9,819	0.23	wall
333+64	333+90	16	416	0.01	standard
Total			10,235	0.23	Flow Control Required

BEGIN SEGMENT B							Soils	Use FCBMPS and Apply Land Use Credits		
<b>TDA 23</b>										
STA Begin	STA End	Trail width (ft)	Trail area (sq-ft)	Impervious area (acre)		OUTWASH				
333+90	334+23	16	528	0.01		standard				
334+23	335+30	18.25	1,953	0.04		wall				
335+30	338+00	16	4,320	0.10		standard				
Total			6,801	0.16		No FC				
<b>TDA 24</b>										
STA Begin	STA End	Trail width (ft)	Trail area (sq-ft)	Impervious area (acre)		OUTWASH				
338+00	338+10	16	160	0.00		standard				
338+10	338+38	16	448	0.01		driveway				
338+38	340+75	16	3,792	0.09		standard				
340+75	341+02	26.5	716	0.02		trail + rest area				
341+02	342+00	16	1,568	0.04		standard				
Total			6,684	0.15		No FC				
<b>TDA 25</b>										
STA Begin	STA End	Trail width (ft)	Trail area (sq-ft)	Impervious area (acre)		TILL				
342+00	342+24	16	384	0.01		standard				
342+24	347+50	18.25	9,600	0.22		wall				
Total			9,984	0.23		Flow Control Required				
<b>TDA 26</b>										
STA Begin	STA End	Trail width (ft)	Trail area (sq-ft)	Impervious area (acre)		TILL				
347+50	347+55	18.25	91	0.00		wall				
347+55	348+35	19.25	1,540	0.04		wall + 3' shoulder				
348+35	349+90	18.25	2,829	0.06		wall				
Total			4,460	0.10		No FC				
<b>TDA 27</b>										
STA Begin	STA End	Trail width (ft)	Trail area (sq-ft)	Impervious area (acre)		TILL				
349+90	351+25	18.25	2,464	0.06		wall				
Total			2,464	0.06		No FC				
<b>TDA 28</b>										
STA Begin	STA End	Trail width (ft)	Trail area (sq-ft)	Impervious area (acre)		TILL				
351+25	351+40	18.25	274	0.01		wall				
351+40	352+00	20.5	1,230	0.03		wall both sides				
352+00	352+71	18.25	1,296	0.03		wall				
352+71	352+78	19.25	135	0.00		wall + 3' shoulder				
352+78	353+27	18	882	0.02		3' shoulder both sides				
Total			3,816	0.09		No FC				
<b>TDA 29</b>							WWHM4 Model Inputs			
STA Begin	STA End	Trail width (ft)	Trail area (sq-ft)	Impervious area (acre)		TILL		Pre-Dev (acre)	Dev (acre)	Notes
353+27	355+00	19.25	3,330	0.08		wall + 3' shoulder	C Forest	0.28		Limited Infiltration Credit 50%Imp/50%Grass from STA 355+40 to STA 359+75
355+00	355+07	17	119	0.00		3' shoulder	C grass		0.09	
355+07	355+40	16	528	0.01		driveway	Imp		0.19	
355+40	356+88	19.25	2,849	0.07		wall + 3' shoulder	total area	0.28	0.28	
356+88	357+45	18.25	1,040	0.02		wall				
357+45	359+75	19.25	4,428	0.10		wall + 3' shoulder				
Total			12,294	0.28		Flow Control Required, so use FCBMPS				
<b>TDA 30</b>										
STA Begin	STA End	Trail width (ft)	Trail area (sq-ft)	Impervious area (acre)		TILL				
359+75	359+77	19.25	39	0.00		wall + 3' shoulder				
359+77	360+99	18.25	2,227	0.05		wall				
360+99	361+15	19.25	308	0.01		wall + 3' shoulder				
Total			2,573	0.06		No FC				
<b>TDA 30A</b>										
STA Begin	STA End	Trail width (ft)	Trail area (sq-ft)	Impervious area (acre)		TILL				
361+15	362+16	19.25	1,944	0.04		wall + 3' shoulder				
Total			1,944	0.04		No FC				
<b>TDA 31</b>										
(STA 361+35, STA 364+00 piped to lake)										
STA Begin	STA End	Trail width (ft)	Trail area (sq-ft)	Impervious area (acre)		TILL				
362+16	365+75	19.25	6,911	0.16		wall + 3' shoulder				
Total			6,911	0.16		No FC				
<b>TDA 32</b>										
STA Begin	STA End	Trail width (ft)	Trail area (sq-ft)	Impervious area (acre)		TILL				
365+75	367+47	19.25	3,311	0.08		wall + 3' shoulder				
367+47	367+64	18.25	310	0.01		wall				
367+64	367+75	25.75	283	0.01		wall + rest area				
Total			3,905	0.09		No FC				
<b>TDA 33</b>										
STA Begin	STA End	Trail width (ft)	Trail area (sq-ft)	Impervious area (acre)		TILL				
367+75	367+85	25.75	258	0.01		wall + rest area				
367+85	367+95	18.25	183	0.00		wall				
367+95	370+89	19.25	5,660	0.13		wall + 3' shoulder				
370+89	371+00	16	176	0.00		standard				
Total			6,276	0.14		No FC				
BEGIN C-LINE (NEW STATIONING)										
<b>TDA 34</b>							WWHM4 Model Inputs			
STA Begin	STA End	Trail width (ft)	Trail area (sq-ft)	Impervious area (acre)		TILL		Pre-Dev (acre)	Dev (acre)	Notes
371+00	371+71	16	1,136	0.03		driveway	A/B Forest	0.33		Limited Infiltration Credit 50%Imp/50%Grass from STA 371+71 to STA 378+80
371+71	374+40	19.25	5,178	0.12		wall + 3' shoulder	A/B grass		0.15	
374+40	375+00	18.25	1,095	0.03		wall	Imp		0.18	
375+00	375+71	17	1,207	0.03		3' shoulder	total area	0.33	0.33	
375+71	376+76	19.25	2,021	0.05		wall + 3' shoulder				
376+76	377+25	17	833	0.02		3' shoulder				
377+25	378+00	18	1,350	0.03		3' shoulder both sides				
378+00	378+73	17	1,241	0.03		3' shoulder				
378+73	378+80	16	112	0.00		driveway				
Total			14,174	0.33		Flow Control Required, so use FCBMPS				



BEGIN SEGMENT B							Soils	Use FCBMPS and Apply Land Use Credits			
<b>TDA 35</b>											
STA Begin	STA End	Trail width (ft)	Trail area (sq-ft)	Impervious area (acre)		TILL					
378+80	378+92	16	192	0.00		driveway					
378+92	379+50	20.5	1,189	0.03		wall both sides					
379+50	380+50	18	1,800	0.04		3' shoulder both sides					
380+50	382+00	19.25	2,888	0.07		wall + 3' shoulder					
Total			6,069	0.14		No FC					
<b>TDA 36</b>											
STA Begin	STA End	Trail width (ft)	Trail area (sq-ft)	Impervious area (acre)		Till					
382+00	383+75	19.25	3,369	0.08		wall + 3' shoulder					
383+75	385+15	20.5	2,870	0.07		wall both sides					
385+15	385+30	16	240	0.01		driveway					
Total			6,479	0.15		No FC					
SE 8th WWHM scale factor changes from 1.167 to 1.0											
<b>TDA 37</b>							WWHM4 Model Inputs				
STA Begin	STA End	Trail width (ft)	Trail area (sq-ft)	Impervious area (acre)		Till	Pre-Dev (acre)	Dev (acre)	Notes		
385+30	385+39	16	144	0.00		driveway	0.20		Basic Dispersion Credit		
385+39	390+19	17	8,160	0.19		3' shoulder		0.09	50%Imp/50%Grass from		
390+19	390+35	16	256	0.01		driveway		0.11	STA 385+40 to STA 390+20		
Total			8,560	0.20		No FC, use FCBMPS	total area	0.20	0.20		
<b>TDA 38</b>											
STA Begin	STA End	Trail width (ft)	Trail area (sq-ft)	Impervious area (acre)		Till					
390+35	391+75	16	2,240	0.05		standard					
391+75	391+85	16	160	0.00		driveway					
Total			2,400	0.06		No FC					
<b>TDA 39</b>											
STA Begin	STA End	Trail width (ft)	Trail area (sq-ft)	Impervious area (acre)		Till					
391+85	391+91	16	96	0.00		driveway					
391+91	393+20	17	2,193	0.05		3' shoulder					
393+20	393+30	16	160	0.00		driveway					
Total			2,449	0.06		No FC					
<b>TDA 40</b>											
STA Begin	STA End	Trail width (ft)	Trail area (sq-ft)	Impervious area (acre)		Till					
393+30	393+43	16	208	0.00		driveway					
393+43	394+77	16	2,144	0.05		standard					
394+77	394+98	23.5	494	0.01		trail + rest area					
394+98	395+73	16	1,200	0.03		standard					
395+73	395+80	16	112	0.00		driveway					
Total			4,158	0.10		No FC					
<b>TDA 41</b>							WWHM4 Model Inputs				
STA Begin	STA End	Trail width (ft)	Trail area (sq-ft)	Impervious area (acre)		TILL	Pre-Dev (acre)	Dev (acre)	Notes		
395+80	395+90	16	987	0.02		driveway	0.27		Limited Infiltration Credit		
395+90	399+02	16	4,992	0.12		standard		0.10	50%Imp/50%Grass from		
399+02	399+24	16	352	0.01		driveway		0.17	STA 395+90 to STA 399+02		
399+24	400+00	17	1,292	0.03		3' shoulder	total area	0.27	0.27		
400+00	400+50	18	900	0.02		3' shoulder both sides			Basic Dispersion Credit		
400+50	401+50	19.25	1,925	0.04		wall + 3' shoulder			50%Imp/50%Grass from		
401+50	401+94	18.25	803	0.02		wall			STA 400+00 to STA 401+50		
401+94	402+30	19.25	693	0.02		wall + 3' shoulder			and STA 401+94 to STA 402+30		
Total			11,944	0.27		Flow Control Required, so use FCBMPS					
<b>TDA 42</b>											
STA Begin	STA End	Trail width (ft)	Trail area (sq-ft)	Impervious area (acre)		Outwash					
402+30	402+75	18.25	821	0.02		wall					
402+75	403+17	17	714	0.02		3' shoulder					
403+17	403+33	16	256	0.01		driveway					
403+33	403+50	17	289	0.01		3' shoulder					
Total			2,080	0.05		No FC					
<b>TDA 43</b>											
STA Begin	STA End	Trail width (ft)	Trail area (sq-ft)	Impervious area (acre)		Outwash					
403+50	405+40	17	3,230	0.07		3' shoulder					
Total			3,230	0.07		No FC					
<b>TDA 44</b>											
STA Begin	STA End	Trail width (ft)	Trail area (sq-ft)	Impervious area (acre)		Outwash					
405+40	405+60	17	340	0.01		3' shoulder					
Total			340	0.01		No FC					
<b>TDA 45</b>											
STA Begin	STA End	Trail width (ft)	Trail area (sq-ft)	Impervious area (acre)		Outwash					
405+60	406+68	17	1,066	0.02		Driveway					
			1,836	0.04		3' shoulder					
Total			2,902	0.07		No FC					
<b>TDA 46</b>											
STA Begin	STA End	Trail width (ft)	Trail area (sq-ft)	Impervious area (acre)		Outwash					
406+68	408+07	17	2,363	0.05		3' shoulder					
408+07	408+15	16	128	0.00		driveway					
Total			2,491	0.06		No FC					
<b>TDA 47</b>							WWHM4 Model Inputs				
STA Begin	STA End	Trail width (ft)	Trail area (sq-ft)	Impervious area (acre)		TILL	Pre-Dev (acre)	Dev (acre)	Notes		
408+15	408+25	16	1,694	0.04		driveway	0.24		Basic Dispersion Credit		
408+25	410+92	18	4,806	0.11		3' shoulder both sides		0.09	50%Imp/50%Grass from		
410+92	411+03	16	176	0.00		driveway		0.15	STA 408+27 to STA 410+83		
411+03	411+82	17	1,343	0.03		3' shoulder	total area	0.24	0.24	and STA 411+06 to STA 411+72	
411+82	411+98	20.5	328	0.01		wall both sides (culvert)			and STA 412+07 to STA 413+15		
411+98	413+22	16	1,984	0.05		standard					
413+22	413+30	16	128	0.00		driveway					
Total			10,459	0.24		Flow Control Required, so use FCBMPS					

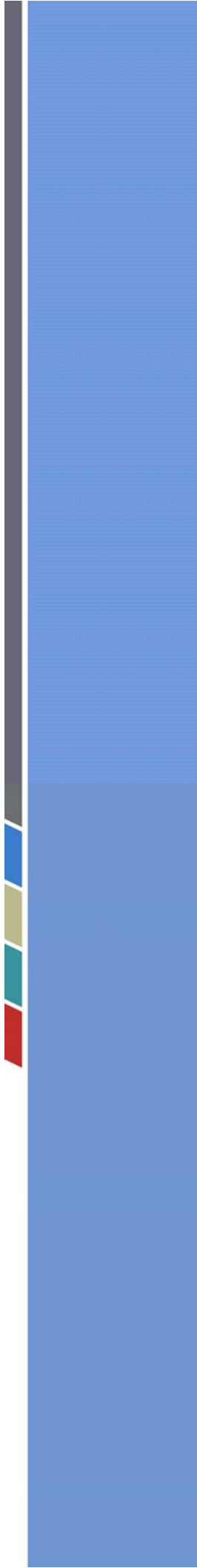
BEGIN SEGMENT B						Soils	Use FCBMPS and Apply Land Use Credits		
TDA 48						WWHM4 Model Inputs			
STA Begin	STA End	Trail width (ft)	Trail area (sq-ft)	Impervious area (acre)	TILL		Pre-Dev (acre)	Dev (acre)	Notes
413+30	413+46	16	256	0.01	driveway	A/B Forest	0.20		Basic Dispersion Credit 50%Imp/50%Grass from STA 413+46 to STA 418+54
413+46	418+13	16	7,472	0.17	standard	A/B grass		0.084	
418+13	418+34	23.5	494	0.01	trail + rest area	Imp		0.115	
418+34	418+55	17	357	0.01	3' shoulder	total area	0.20	0.20	
418+55	418+60	16	80	0.00	driveway				
Total				8,659	0.20	Flow Control Required, so use FCBMPS			
BEGIN D-LINE (NEW STATIONING)									
TDA 49						WWHM4 Model Inputs			
STA Begin	STA End	Trail width (ft)	Trail area (sq-ft)	Impervious area (acre)	TILL		Pre-Dev (acre)	Dev (acre)	Notes
419+05	419+15	16	160	0.00	driveway	A/B Forest	0.21		Basic Dispersion Credit 50%Imp/50%Grass from STA 420+25 to STA 424+20
419+15	420+25	16	1,760	0.04	standard	A/B grass		0.08	
420+25	421+19	17	1,598	0.04	3' shoulder	Imp		0.13	
421+19	424+20	18	5,418	0.12	3' shoulder both sides	total area	0.21	0.21	
Total				8,936	0.21	No FC, use FCBMPS			
TDA 50									
STA Begin	STA End	Trail width (ft)	Trail area (sq-ft)	Impervious area (acre)	TILL				
424+20	424+75	17	935	0.02	3' shoulder				
Total				935	0.02	No FC			
TDA 51									
STA Begin	STA End	Trail width (ft)	Trail area (sq-ft)	Impervious area (acre)	TILL				
424+75	425+20	17	765	0.02	3' shoulder				
425+20	425+52	16	512	0.01	3' shoulder both sides				
425+52	426+35	17	1,411	0.03	3' shoulder				
Total				2,688	0.06	No FC			
TDA 52						WWHM4 Model Inputs			
STA Begin	STA End	Trail width (ft)	Trail area (sq-ft)	Impervious area (acre)	TILL		Pre-Dev (acre)	Dev (acre)	Notes
426+35	431+70	17	9,095	0.21	3' shoulder both sides	A/B Forest	0.21		Basic Dispersion Credit 50%Imp/50%Grass from STA 426+34 to STA 431+63
Total						A/B grass		0.10	
						Imp		0.11	
						total area	0.21	0.21	
TDA 53									
STA Begin	STA End	Trail width (ft)	Trail area (sq-ft)	Impervious area (acre)	TILL				
431+70	431+80	19.25	193	0.00	wall + 3' shoulder				
431+80	432+18	18.25	694	0.02	wall				
432+18	433+00	17	1,394	0.03	3' shoulder				
433+00	434+50	18.25	2,738	0.06	wall				
432+00	432+50	-	1,455	0.03	Parkway access route near Louis Thompson Rd				
Total				6,473	0.15	No FC			
TDA 54									
STA Begin	STA End	Trail width (ft)	Trail area (sq-ft)	Impervious area (acre)	TILL				
434+50	435+90	18.25	2,555	0.06	wall				
435+90	438+20	19.25	4,428	0.10	wall + 3' shoulder				
438+20	438+44	18	432	0.01	3' shoulder both sides				
438+44	438+66	16	352	0.01	driveway				
438+66	441+10	16	3,904	0.09	standard				
Total				11,671	0.27	Flow Control Required			
TDA 55									
STA Begin	STA End	Trail width (ft)	Trail area (sq-ft)	Impervious area (acre)	TILL				
441+10	441+35	16	400	0.01	standard				
441+35	441+45	20.5	205	0.00	wall both sides (box culvert)				
441+45	443+62	16	3,472	0.08	standard				
443+62	443+83	16	336	0.01	trail + rest area				
443+83	444+17	16	544	0.01	standard				
444+17	444+30	16	208	0.00	driveway				
Total				5,165	0.12	No FC			
TDA 56									
STA Begin	STA End	Trail width (ft)	Trail area (sq-ft)	Impervious area (acre)	TILL				
444+30	444+42	16	192	0.00	driveway				
444+42	445+00	18	1,044	0.02	3' shoulder both sides				
445+00	445+78	19.25	1,502	0.03	wall + 3' shoulder				
445+78	446+78	17	1,700	0.04	3' shoulder				
446+78	447+60	16	1,312	0.03	standard				
447+60	448+66	17	1,802	0.04	3' shoulder				
Total				7,552	0.17	No FC			
TDA 57									
STA Begin	STA End	Trail width (ft)	Trail area (sq-ft)	Impervious area (acre)	TILL				
448+66	448+90	17	408	0.01	3' shoulder				
448+90	450+70	19.25	3,465	0.08	wall + 3' shoulder				
450+00	450+70	-	3,090	0.07	Parking Area near Parkway				
Total				6,963	0.16	No FC			
TDA 58									
STA Begin	STA End	Trail width (ft)	Trail area (sq-ft)	Impervious area (acre)	TILL				
450+70	451+65	19.25	1,829	0.04	wall + 3' shoulder				
451+65	453+00	17	2,295	0.05	3' shoulder				
453+00	453+95	19.25	1,829	0.04	wall + 3' shoulder				
Total				5,953	0.14	No FC			
TDA 59									
STA Begin	STA End	Trail width (ft)	Trail area (sq-ft)	Impervious area (acre)	TILL				
453+95	454+65	19.25	1,348	0.03	wall + 3' shoulder				
Total				1,348	0.03	No FC			

BEGIN SEGMENT B		Soils			Use FCBMPS and Apply Land Use Credits	
<b>TDA 60</b>						
STA Begin	STA End	Trail width (ft)	Trail area (sq-ft)	Impervious area (acre)	TILL	
454+65	454+70	19.25	96	0.00	wall + 3' shoulder	
454+70	455+50	17	1,360	0.03	3' shoulder	
455+50	456+30	18	1,440	0.03	3' shoulder both sides	
Total			2,896	0.07	No FC	
<b>TDA 60A</b>						
STA Begin	STA End	Trail width (ft)	Trail area (sq-ft)	Impervious area (acre)	TILL	
456+30	456+35	18	90	0.00	3' shoulder both sides	
456+35	457+90	19.25	2,984	0.07	wall + 3' shoulder	
457+90	458+65	18.25	1,369	0.03	wall	
Total			4,443	0.10	No FC	
<b>TDA 61</b>						
STA Begin	STA End	Trail width (ft)	Trail area (sq-ft)	Impervious area (acre)	TILL	
458+65	459+29	18.25	1,168	0.03	wall	
459+29	460+08	16	1,264	0.03	driveway	
460+08	460+48	20.5	820	0.02	wall both sides	
460+48	461+00	19.25	1,001	0.02	wall + 3' shoulder	
Total			4,253	0.10	No FC	
<b>TDA 62</b>						
STA Begin	STA End	Trail width (ft)	Trail area (sq-ft)	Impervious area (acre)	TILL	
461+00	461+21	19.25	404	0.01	wall + 3' shoulder	
461+21	461+75	17	918	0.02	3' shoulder	
461+75	464+39	19.25	5,082	0.12	wall + 3' shoulder	
464+39	464+50	18.25	201	0.00	wall	
Total			6,605	0.15	No FC	
<b>TDA 63</b>						
STA Begin	STA End	Trail width (ft)	Trail area (sq-ft)	Impervious area (acre)	TILL	
464+50	467+00	18.25	4,563	0.10	wall	
Total			4,563	0.10	No FC	





## C2 – WWHM2012 Outputs





**WWHM2012  
PROJECT REPORT**

---

**Project Name:** TDAExemptOutwashS  
**Site Name:** ELST - South of SE 8th (Outwash Soil)  
**Site Address:** S. Sam B  
**City** : Sammamish  
**Report Date:** 8/16/2016  
**Gage** : Seatac  
**Data Start** : 1948/10/01 00:00  
**Data End** : 2009/09/30 00:00  
**Precip Scale:** 1.17  
**Version Date:** 2016/05/12  
**Version** : 4.2.12  
**Timestep** : 1-hour

---

**Low Flow Threshold for POC 1** : 50 Percent of the 2 Year

---

**High Flow Threshold for POC 1:** 50 year

---

**PREDEVELOPED LAND USE**

**Name** : Basin 1  
**Bypass:** No

**GroundWater:** No

<u>Pervious Land Use</u>	<u>acre</u>
A B, Forest, Flat	.17
<b>Pervious Total</b>	<b>0.17</b>
<u>Impervious Land Use</u>	<u>acre</u>
<b>Impervious Total</b>	<b>0</b>
<b>Basin Total</b>	<b>0.17</b>

---

**Element Flows To:**

<b>Surface</b>	<b>Interflow</b>	<b>Groundwater</b>
----------------	------------------	--------------------

---

**MITIGATED LAND USE**

**Name** : Basin 1  
**Bypass:** No

**GroundWater:** No

<u>Pervious Land Use</u>	<u>acre</u>
Pervious Total	0
<u>Impervious Land Use</u>	<u>acre</u>
SIDEWALKS FLAT	0.17
Impervious Total	0.17
Basin Total	0.17

Element Flows To:		
Surface	Interflow	Groundwater

**ANALYSIS RESULTS**

Predeveloped Landuse Totals for POC #1  
 Total Pervious Area:0.17  
 Total Impervious Area:0

Mitigated Landuse Totals for POC #1  
 Total Pervious Area:0  
 Total Impervious Area:0.17

Flow Frequency Return Periods for Predeveloped. POC #1

<u>Return Period</u>	<u>Flow(cfs)</u>	
2 year	0.000049	
5 year	0.000151	
10 year	0.0003	
25 year	0.000673	
50 year	0.001184	
100 year	0.002028	β 100-year predeveloped

Flow Frequency Return Periods for Mitigated. POC #1

<u>Return Period</u>	<u>Flow(cfs)</u>	
2 year	0.051457	
5 year	0.064528	
10 year	0.07354	
25 year	0.085365	
50 year	0.094507	
100 year	0.103946	β 100-year developed

**PerlnD and Implnd Changes**  
 No changes have been made.

Increase in 100-year flow no greater than 0.1 cfs; therefore, no flow control facility is required.



WWHM2012  
PROJECT REPORT

---

**Project Name:** TDAExemptTills  
**Site Name:** ELST - South of SE 8th (Till Soil)  
**Site Address:** S. Sam B  
**City** : Sammamish  
**Report Date:** 8/16/2016  
**Gage** : Seatac  
**Data Start** : 1948/10/01 00:00  
**Data End** : 2009/09/30 00:00  
**Precip Scale:** 1.17  
**Version Date:** 2016/05/12  
**Version** : 4.2.12  
**Timestep** : 1-hour

---

**Low Flow Threshold for POC 1** : 50 Percent of the 2 Year

---

**High Flow Threshold for POC 1:** 50 year

---

**PREDEVELOPED LAND USE**

**Name** : Basin 1  
**Bypass:** No

**GroundWater:** No

<u>Pervious Land Use</u>	<u>acre</u>
C, Forest, Flat	.2

Pervious Total	0.2
----------------	-----

<u>Impervious Land Use</u>	<u>acre</u>
----------------------------	-------------

Impervious Total	0
------------------	---

Basin Total	0.2
-------------	-----

---

**Element Flows To:**

Surface	Interflow	Groundwater
---------	-----------	-------------

---

**MITIGATED LAND USE**

**Name** : Basin 1  
**Bypass:** No

**GroundWater:** No

<u>Pervious Land Use</u>	<u>acre</u>
Pervious Total	0
<u>Impervious Land Use</u>	<u>acre</u>
SIDEWALKS FLAT	0.2
Impervious Total	0.2
Basin Total	0.2

Element Flows To:		
Surface	Interflow	Groundwater

ANALYSIS RESULTS

Predeveloped Landuse Totals for POC #1  
 Total Pervious Area:0.2  
 Total Impervious Area:0

Mitigated Landuse Totals for POC #1  
 Total Pervious Area:0  
 Total Impervious Area:0.2

Flow Frequency Return Periods for Predeveloped. POC #1

<u>Return Period</u>	<u>Flow(cfs)</u>	
2 year	0.007118	
5 year	0.011358	
10 year	0.014114	
25 year	0.017451	
50 year	0.019809	
100 year	0.022052	β 100-year predeveloped

Flow Frequency Return Periods for Mitigated. POC #1

<u>Return Period</u>	<u>Flow(cfs)</u>	
2 year	0.060538	
5 year	0.075915	
10 year	0.086518	
25 year	0.100429	
50 year	0.111184	
100 year	0.122289	β 100-year developed

PerlnD and Implnd Changes

No changes have been made.

Increase in 100-year flow no greater than 0.1 cfs; therefore, no flow control facility is required.

WWHM2012  
PROJECT REPORT

---

**Project Name:** TDAExemptOutwashN  
**Site Name:** ELST - North of SE 8th (Outwash Soil)  
**Site Address:** S. Sam B  
**City** : Sammamish  
**Report Date:** 8/16/2016  
**Gage** : Seatac  
**Data Start** : 1948/10/01 00:00  
**Data End** : 2009/09/30 00:00  
**Precip Scale:** 1.00  
**Version Date:** 2016/05/12  
**Version** : 4.2.12  
**Timestep** : 1-hour

---

**Low Flow Threshold for POC 1** : 50 Percent of the 2 Year

---

**High Flow Threshold for POC 1:** 50 year

---

**PREDEVELOPED LAND USE**

**Name** : Basin 1  
**Bypass:** No

**GroundWater:** No

<u>Pervious Land Use</u>	<u>acre</u>
A B, Forest, Flat	.19
<b>Pervious Total</b>	<b>0.19</b>
<u>Impervious Land Use</u>	<u>acre</u>
<b>Impervious Total</b>	<b>0</b>
<b>Basin Total</b>	<b>0.19</b>

---

**Element Flows To:**

Surface	Interflow	Groundwater
---------	-----------	-------------

---

**MITIGATED LAND USE**

**Name** : Basin 1  
**Bypass:** No

**GroundWater:** No

<u>Pervious Land Use</u>	<u>acre</u>
Pervious Total	0
<u>Impervious Land Use</u>	<u>acre</u>
SIDEWALKS FLAT	0.19
Impervious Total	0.19
Basin Total	0.19

Element Flows To:		
Surface	Interflow	Groundwater

ANALYSIS RESULTS

Predeveloped Landuse Totals for POC #1  
 Total Pervious Area:0.19  
 Total Impervious Area:0

Mitigated Landuse Totals for POC #1  
 Total Pervious Area:0  
 Total Impervious Area:0.19

Flow Frequency Return Periods for Predeveloped. POC #1

<u>Return Period</u>	<u>Flow(cfs)</u>	
2 year	0.00004	
5 year	0.000064	
10 year	0.000084	
25 year	0.000114	
50 year	0.00014	
100 year	0.00017	β 100-year predeveloped

Flow Frequency Return Periods for Mitigated. POC #1

<u>Return Period</u>	<u>Flow(cfs)</u>	
2 year	0.048588	
5 year	0.060963	
10 year	0.069499	
25 year	0.080703	
50 year	0.089368	
100 year	0.098317	β 100-year developed

**PerlnD and Implnd Changes**

No changes have been made.

Increase in 100-year flow is less than 0.1 cfs; therefore, no flow control facility is required.



WWHM2012  
PROJECT REPORT

---

**Project Name:** TDAExemptTillN  
**Site Name:** ELST - North of SE 8th (Till Soil)  
**Site Address:** S. Sam B  
**City** : Sammamish  
**Report Date:** 8/16/2016  
**Gage** : Seatac  
**Data Start** : 1948/10/01 00:00  
**Data End** : 2009/09/30 00:00  
**Precip Scale:** 1.00  
**Version Date:** 2016/05/12  
**Version** : 4.2.12  
**Timestep** : 1-hour

---

**Low Flow Threshold for POC 1** : 50 Percent of the 2 Year

---

**High Flow Threshold for POC 1:** 50 year

---

**PREDEVELOPED LAND USE**

**Name** : Basin 1  
**Bypass:** No

**GroundWater:** No

<u>Pervious Land Use</u>	<u>acre</u>
C, Forest, Flat	.21
<b>Pervious Total</b>	<b>0.21</b>
<u>Impervious Land Use</u>	<u>acre</u>
<b>Impervious Total</b>	<b>0</b>
<b>Basin Total</b>	<b>0.21</b>

---

**Element Flows To:**

<b>Surface</b>	<b>Interflow</b>	<b>Groundwater</b>
----------------	------------------	--------------------

---

**MITIGATED LAND USE**

**Name** : Basin 1  
**Bypass:** No

**GroundWater:** No

<u>Pervious Land Use</u>	<u>acre</u>
Pervious Total	0
<u>Impervious Land Use</u>	<u>acre</u>
SIDEWALKS FLAT	0.21
Impervious Total	0.21
Basin Total	0.21

Element Flows To:		
Surface	Interflow	Groundwater

ANALYSIS RESULTS

Predeveloped Landuse Totals for POC #1  
 Total Pervious Area:0.21  
 Total Impervious Area:0

Mitigated Landuse Totals for POC #1  
 Total Pervious Area:0  
 Total Impervious Area:0.21

Flow Frequency Return Periods for Predeveloped. POC #1

<u>Return Period</u>	<u>Flow(cfs)</u>	
2 year	0.005536	
5 year	0.008907	
10 year	0.010781	
25 year	0.012711	
50 year	0.013869	
100 year	0.014826	β 100-year predeveloped

Flow Frequency Return Periods for Mitigated. POC #1

<u>Return Period</u>	<u>Flow(cfs)</u>	
2 year	0.053702	
5 year	0.06738	
10 year	0.076815	
25 year	0.089198	
50 year	0.098775	
100 year	0.108666	β 100-year developed

PerlnD and Implnd Changes  
 No changes have been made.

Increase in 100-year flow is less than 0.1 cfs; therefore, no flow control facility is required.

WWHM2012  
PROJECT REPORT

---

**Project Name:** TDAs11-12-InfilChamber  
**Site Name:** TDAs 11 and 12  
**Site Address:** Station 288+00  
**City** : Sammamish  
**Report Date:** 8/17/2016  
**Gage** : Seatac  
**Data Start** : 1948/10/01  
**Data End** : 2009/09/30  
**Precip Scale:** 1.17  
**Version Date:** 2016/05/12  
**Version** : 4.2.12

**Timestep** : 1-hour

---

**Low Flow Threshold for POC 1** : 50 Percent of the 2 Year

---

**High Flow Threshold for POC 1:** 50 year

---

**PREDEVELOPED LAND USE**

**Name** : TDA 11  
**Bypass:** No

**GroundWater:** No

<u>Pervious Land Use</u>	<u>acre</u>
A B, Forest, Flat	.32
<b>Pervious Total</b>	<b>0.32</b>
<u>Impervious Land Use</u>	<u>acre</u>
<b>Impervious Total</b>	<b>0</b>
<b>Basin Total</b>	<b>0.32</b>

---

**Element Flows To:**

<b>Surface</b>	<b>Interflow</b>	<b>Groundwater</b>
----------------	------------------	--------------------

---

**Name** : TDA 12  
**Bypass:** No

**GroundWater:** No

<u>Pervious Land Use</u>	<u>acre</u>
A B, Forest, Flat	.18
Pervious Total	0.18
<u>Impervious Land Use</u>	<u>acre</u>
Impervious Total	0
Basin Total	0.18

---

Element Flows To:		
Surface	Interflow	Groundwater

---

MITIGATED LAND USE

Name : TDA 11  
 Bypass: No

GroundWater: No

<u>Pervious Land Use</u>	<u>acre</u>
Pervious Total	0
<u>Impervious Land Use</u>	<u>acre</u>
SIDEWALKS FLAT	0.32
Impervious Total	0.32
Basin Total	0.32

---

Element Flows To:		
Surface	Interflow	Groundwater
StormTech MC3500 - SSDStormTech MC3500 - SSD		

---

Name : TDA 12  
 Bypass: No

GroundWater: No

<u>Pervious Land Use</u>	<u>acre</u>
Pervious Total	0
<u>Impervious Land Use</u>	<u>acre</u>





2.417	0.012	0.025	0.000	0.123	0.000	0.000	0.000
2.500	0.012	0.026	0.000	0.123	0.000	0.000	0.000
2.583	0.012	0.027	0.000	0.123	0.000	0.000	0.000
2.667	0.012	0.028	0.000	0.123	0.000	0.000	0.000
2.750	0.012	0.029	0.000	0.123	0.000	0.000	0.000
2.833	0.012	0.030	0.000	0.123	0.000	0.000	0.000
2.917	0.012	0.031	0.000	0.123	0.000	0.000	0.000
3.000	0.012	0.032	0.000	0.123	0.000	0.000	0.000
3.083	0.012	0.033	0.000	0.123	0.000	0.000	0.000
3.167	0.012	0.034	0.000	0.123	0.000	0.000	0.000
3.250	0.012	0.035	0.000	0.123	0.000	0.000	0.000
3.333	0.012	0.036	0.000	0.123	0.000	0.000	0.000
3.417	0.012	0.037	0.000	0.123	0.000	0.000	0.000
3.500	0.012	0.037	0.000	0.123	0.000	0.000	0.000
3.583	0.012	0.038	0.000	0.123	0.000	0.000	0.000
3.667	0.012	0.039	0.000	0.123	0.000	0.000	0.000
3.750	0.012	0.040	0.000	0.123	0.000	0.000	0.000
3.833	0.012	0.041	0.000	0.123	0.000	0.000	0.000
3.917	0.012	0.041	0.000	0.123	0.000	0.000	0.000
4.000	0.012	0.042	0.000	0.123	0.000	0.000	0.000
4.083	0.012	0.043	0.000	0.123	0.000	0.000	0.000
4.167	0.012	0.043	0.000	0.123	0.000	0.000	0.000
4.250	0.012	0.044	0.000	0.123	0.000	0.000	0.000
4.333	0.012	0.044	0.000	0.123	0.000	0.000	0.000
4.417	0.012	0.045	0.000	0.123	0.000	0.000	0.000
4.500	0.012	0.045	0.000	0.123	0.000	0.000	0.000
4.583	0.012	0.046	0.382	0.123	0.000	0.000	0.000
4.667	0.012	0.046	1.074	0.123	0.000	0.000	0.000
4.750	0.012	0.047	1.938	0.123	0.000	0.000	0.000
4.833	0.012	0.047	2.883	0.123	0.000	0.000	0.000
4.917	0.012	0.048	3.813	0.123	0.000	0.000	0.000
5.000	0.012	0.048	4.639	0.123	0.000	0.000	0.000
5.083	0.012	0.049	5.294	0.123	0.000	0.000	0.000
5.167	0.012	0.049	5.754	0.123	0.000	0.000	0.000
5.250	0.012	0.050	6.072	0.123	0.000	0.000	0.000
5.333	0.012	0.050	6.469	0.123	0.000	0.000	0.000
5.417	0.012	0.051	6.785	0.123	0.000	0.000	0.000
5.500	0.012	0.051	7.087	0.123	0.000	0.000	0.000

---



---

**ANALYSIS RESULTS**

**Stream Protection Duration**

---

**Predeveloped Landuse Totals for POC #1**

**Total Pervious Area:0.5**

**Total Impervious Area:0**

---

**Mitigated Landuse Totals for POC #1**

**Total Pervious Area:0**

**Total Impervious Area:0.5**

---

**Flow Frequency Return Periods for Predeveloped. POC #1**

<u>Return Period</u>	<u>Flow(cfs)</u>
2 year	0.000145
5 year	0.000446
10 year	0.000883
25 year	0.001979
50 year	0.003482
100 year	0.005964

**Flow Frequency Return Periods for Mitigated. POC #1**

<u>Return Period</u>	<u>Flow(cfs)</u>
2 year	0
5 year	0
10 year	0
25 year	0
50 year	0
100 year	0

---

**Stream Protection Duration**

**Annual Peaks for Predeveloped and Mitigated. POC #1**

<u>Year</u>	<u>Predeveloped</u>	<u>Mitigated</u>
1949	0.000	0.000
1950	0.006	0.000
1951	0.003	0.000
1952	0.000	0.000
1953	0.000	0.000
1954	0.000	0.000
1955	0.000	0.000
1956	0.000	0.000
1957	0.000	0.000
1958	0.000	0.000
1959	0.000	0.000
1960	0.000	0.000
1961	0.000	0.000
1962	0.000	0.000
1963	0.000	0.000
1964	0.000	0.000
1965	0.000	0.000
1966	0.000	0.000
1967	0.000	0.000
1968	0.000	0.000
1969	0.000	0.000
1970	0.000	0.000
1971	0.000	0.000
1972	0.003	0.000
1973	0.000	0.000
1974	0.000	0.000
1975	0.000	0.000
1976	0.000	0.000
1977	0.000	0.000
1978	0.000	0.000
1979	0.000	0.000
1980	0.000	0.000
1981	0.000	0.000
1982	0.000	0.000

1983	0.000	0.000
1984	0.000	0.000
1985	0.000	0.000
1986	0.000	0.000
1987	0.000	0.000
1988	0.000	0.000
1989	0.000	0.000
1990	0.000	0.000
1991	0.002	0.000
1992	0.000	0.000
1993	0.000	0.000
1994	0.000	0.000
1995	0.000	0.000
1996	0.004	0.000
1997	0.001	0.000
1998	0.000	0.000
1999	0.000	0.000
2000	0.000	0.000
2001	0.000	0.000
2002	0.000	0.000
2003	0.000	0.000
2004	0.000	0.099
2005	0.000	0.000
2006	0.000	0.000
2007	0.025	0.000
2008	0.000	0.063
2009	0.000	0.000

---

**Stream Protection Duration**

**Ranked Annual Peaks for Predeveloped and Mitigated. POC #1**

<b>Rank</b>	<b>Predeveloped</b>	<b>Mitigated</b>
1	0.0248	0.0995
2	0.0063	0.0634
3	0.0040	0.0000
4	0.0034	0.0000
5	0.0027	0.0000
6	0.0020	0.0000
7	0.0011	0.0000
8	0.0005	0.0000
9	0.0004	0.0000
10	0.0003	0.0000
11	0.0003	0.0000
12	0.0002	0.0000
13	0.0002	0.0000
14	0.0002	0.0000
15	0.0002	0.0000
16	0.0001	0.0000
17	0.0001	0.0000
18	0.0001	0.0000
19	0.0001	0.0000
20	0.0001	0.0000
21	0.0001	0.0000
22	0.0001	0.0000
23	0.0001	0.0000
24	0.0001	0.0000
25	0.0001	0.0000



26	0.0001	0.0000
27	0.0001	0.0000
28	0.0001	0.0000
29	0.0001	0.0000
30	0.0001	0.0000
31	0.0001	0.0000
32	0.0001	0.0000
33	0.0001	0.0000
34	0.0001	0.0000
35	0.0001	0.0000
36	0.0001	0.0000
37	0.0001	0.0000
38	0.0001	0.0000
39	0.0001	0.0000
40	0.0001	0.0000
41	0.0001	0.0000
42	0.0001	0.0000
43	0.0001	0.0000
44	0.0001	0.0000
45	0.0001	0.0000
46	0.0001	0.0000
47	0.0001	0.0000
48	0.0001	0.0000
49	0.0001	0.0000
50	0.0001	0.0000
51	0.0001	0.0000
52	0.0001	0.0000
53	0.0001	0.0000
54	0.0001	0.0000
55	0.0001	0.0000
56	0.0001	0.0000
57	0.0001	0.0000
58	0.0001	0.0000
59	0.0001	0.0000
60	0.0001	0.0000
61	0.0001	0.0000

---

**Stream Protection Duration**  
**POC #1**

Facility **FAILED** duration standard for 1+ flows.

Flow(cfs)	Predev	Mit	Percentage	Pass/Fail
0.0001	1462	8	0	Pass
0.0001	246	8	3	Pass
0.0001	198	8	4	Pass
0.0002	163	8	4	Pass
0.0002	145	8	5	Pass
0.0002	133	8	6	Pass
0.0003	119	8	6	Pass
0.0003	108	8	7	Pass
0.0003	94	8	8	Pass
0.0004	83	8	9	Pass
0.0004	80	8	10	Pass
0.0005	75	8	10	Pass
0.0005	65	8	12	Pass

0.0005	63	8	12	Pass
0.0006	60	8	13	Pass
0.0006	58	8	13	Pass
0.0006	52	8	15	Pass
0.0007	49	8	16	Pass
0.0007	48	8	16	Pass
0.0007	48	8	16	Pass
0.0008	47	8	17	Pass
0.0008	46	8	17	Pass
0.0008	44	8	18	Pass
0.0009	44	8	18	Pass
0.0009	39	8	20	Pass
0.0009	37	8	21	Pass
0.0010	37	8	21	Pass
0.0010	36	8	22	Pass
0.0010	35	8	22	Pass
0.0011	33	8	24	Pass
0.0011	30	8	26	Pass
0.0011	27	8	29	Pass
0.0012	27	8	29	Pass
0.0012	27	8	29	Pass
0.0012	26	8	30	Pass
0.0013	26	8	30	Pass
0.0013	24	8	33	Pass
0.0013	24	8	33	Pass
0.0014	22	8	36	Pass
0.0014	22	8	36	Pass
0.0015	22	8	36	Pass
0.0015	22	8	36	Pass
0.0015	21	8	38	Pass
0.0016	20	8	40	Pass
0.0016	20	8	40	Pass
0.0016	20	8	40	Pass
0.0017	20	8	40	Pass
0.0017	19	8	42	Pass
0.0017	19	8	42	Pass
0.0018	19	8	42	Pass
0.0018	19	8	42	Pass
0.0018	17	8	47	Pass
0.0019	16	8	50	Pass
0.0019	16	8	50	Pass
0.0019	16	8	50	Pass
0.0020	15	8	53	Pass
0.0020	15	8	53	Pass
0.0020	14	8	57	Pass
0.0021	13	8	61	Pass
0.0021	13	8	61	Pass
0.0021	13	8	61	Pass
0.0022	13	8	61	Pass
0.0022	13	8	61	Pass
0.0022	13	8	61	Pass
0.0023	13	8	61	Pass
0.0023	12	8	66	Pass
0.0023	11	8	72	Pass
0.0024	11	8	72	Pass
0.0024	11	8	72	Pass
0.0024	10	8	80	Pass

0.0025	9	8	88	Pass
0.0025	9	8	88	Pass
0.0026	9	8	88	Pass
0.0026	9	8	88	Pass
0.0026	9	8	88	Pass
0.0027	9	8	88	Pass
0.0027	7	7	100	Pass
0.0027	7	7	100	Pass
0.0028	7	7	100	Pass
0.0028	7	7	100	Pass
0.0028	7	7	100	Pass
0.0029	7	7	100	Pass
0.0029	7	7	100	Pass
0.0029	7	7	100	Pass
0.0030	7	7	100	Pass
0.0030	7	7	100	Pass
0.0030	6	7	116	Fail
0.0031	6	7	116	Fail
0.0031	6	7	116	Fail
0.0031	6	7	116	Fail
0.0032	6	7	116	Fail
0.0032	6	7	116	Fail
0.0032	6	7	116	Fail
0.0033	6	7	116	Fail
0.0033	6	7	116	Fail
0.0033	6	7	116	Fail
0.0033	6	7	116	Fail
0.0034	6	7	116	Fail
0.0034	6	7	116	Fail
0.0034	5	7	140	Fail
0.0035	5	7	140	Fail

---

The development has an increase in flow durations from 1/2 Predeveloped 2 year flow to the 2 year flow or more than a 10% increase from the 2 year to the 50 year flow.

---

Water Quality BMP Flow and Volume for POC #1  
On-line facility volume: 0 acre-feet  
On-line facility target flow: 0 cfs.  
Adjusted for 15 min: 0 cfs.  
Off-line facility target flow: 0 cfs.  
Adjusted for 15 min: 0 cfs.

---

#### LID Report

LID Technique	Water Quality	Used for Percent Treatment?	Total Volumn Comment Needs Treatment (ac-ft)	Volumn Through Facility (ac-ft)	Infiltration Volumn (ac-ft.)	Cumulative Volumn Infiltration Credit
StormTech MC3500 - SSD Table P		N	85.88			N 99.80
Total Volume Infiltrated			85.88	0.00	0.00	
99.80	0.00	0%	No Treat. Credit			
Compliance with LID Standard 8						
Duration Analysis Result = Passed						

---

**Perlnd and Implnd Changes**

No changes have been made.

---

This program and accompanying documentation are provided 'as-is' without warranty of any kind. The entire risk regarding the performance and results of this program is assumed by End User. Clear Creek Solutions Inc. and the governmental licensee or sublicensees disclaim all warranties, either expressed or implied, including but not limited to implied warranties of program and accompanying documentation. In no event shall Clear Creek Solutions Inc. be liable for any damages whatsoever (including without limitation to damages for loss of business profits, loss of business information, business interruption, and the like) arising out of the use of, or inability to use this program even if Clear Creek Solutions Inc. or their authorized representatives have been advised of the possibility of such damages. Software Copyright © by : Clear Creek Solutions, Inc. 2005-2016; All Rights Reserved.



**Project: ELST - SouthSammamish Segment B**



Chamber Model -	MC-3500
Units -	Imperial
Number of Chambers -	12
Number of End Caps -	2
Voids in the stone (porosity) -	40 %
Base of Stone Elevation -	38.50 ft
Amount of Stone Above Chambers -	12 in
Amount of Stone Below Chambers -	9 in

Include Perimeter Stone in Calculations

**StormTech MC-3500 Cumulative Storage Volumes**

Height of System (inches)	Incremental Single Chamber (cubic feet)	Incremental Single End Cap (cubic feet)	Incremental Chambers (cubic feet)	Incremental End Cap (cubic feet)	Incremental Stone (cubic feet)	Incremental Ch, EC and Stone (cubic feet)	Cumulative System (cubic feet)	Elevation (feet)
66	0.00	0.00	0.00	0.00	21.68	21.68	2241.42	44.00
65	0.00	0.00	0.00	0.00	21.68	21.68	2219.74	43.92
64	0.00	0.00	0.00	0.00	21.68	21.68	2198.05	43.83
63	0.00	0.00	0.00	0.00	21.68	21.68	2176.37	43.75
62	0.00	0.00	0.00	0.00	21.68	21.68	2154.69	43.67
61	0.00	0.00	0.00	0.00	21.68	21.68	2133.01	43.58
60	0.00	0.00	0.00	0.00	21.68	21.68	2111.32	43.50
59	0.00	0.00	0.00	0.00	21.68	21.68	2089.64	43.42
58	0.00	0.00	0.00	0.00	21.68	21.68	2067.96	43.33
57	0.00	0.00	0.00	0.00	21.68	21.68	2046.28	43.25
56	0.00	0.00	0.00	0.00	21.68	21.68	2024.60	43.17
55	0.00	0.00	0.00	0.00	21.68	21.68	2002.91	43.08
54	0.06	0.00	0.70	0.00	21.40	22.10	1981.23	43.00
53	0.19	0.01	2.33	0.02	20.74	23.09	1959.13	42.92
52	0.29	0.01	3.53	0.02	20.26	23.81	1936.04	42.83
51	0.40	0.02	4.84	0.04	19.73	24.61	1912.23	42.75
50	0.69	0.04	8.25	0.08	18.35	26.68	1887.62	42.67
49	1.03	0.05	12.34	0.10	16.71	29.15	1860.94	42.58
48	1.25	0.07	14.99	0.14	15.63	30.76	1831.79	42.50
47	1.42	0.09	17.07	0.18	14.78	32.03	1801.03	42.42
46	1.57	0.10	18.88	0.20	14.05	33.13	1769.00	42.33
45	1.71	0.12	20.49	0.24	13.39	34.12	1735.87	42.25
44	1.83	0.14	21.94	0.28	12.79	35.02	1701.75	42.17
43	1.94	0.16	23.25	0.32	12.25	35.83	1666.74	42.08
42	2.04	0.18	24.49	0.36	11.74	36.59	1630.91	42.00
41	2.13	0.20	25.62	0.40	11.28	37.29	1594.32	41.92
40	2.22	0.21	26.69	0.42	10.84	37.95	1557.03	41.83
39	2.31	0.24	27.68	0.48	10.42	38.58	1519.08	41.75
38	2.38	0.26	28.62	0.52	10.03	39.16	1480.50	41.67
37	2.46	0.27	29.51	0.54	9.66	39.71	1441.33	41.58
36	2.53	0.29	30.34	0.58	9.32	40.23	1401.62	41.50
35	2.59	0.32	31.12	0.64	8.98	40.74	1361.39	41.42
34	2.66	0.33	31.87	0.66	8.67	41.20	1320.65	41.33
33	2.72	0.35	32.58	0.70	8.37	41.65	1279.44	41.25
32	2.77	0.37	33.26	0.74	8.08	42.08	1237.79	41.17
31	2.82	0.39	33.90	0.78	7.81	42.49	1195.71	41.08
30	2.88	0.41	34.51	0.82	7.55	42.88	1153.23	41.00
29	2.92	0.43	35.09	0.86	7.30	43.25	1110.35	40.92
28	2.97	0.45	35.64	0.90	7.07	43.61	1067.10	40.83
27	3.01	0.46	36.15	0.92	6.85	43.92	1023.49	40.75
26	3.05	0.48	36.64	0.96	6.64	44.24	979.57	40.67
25	3.09	0.49	37.13	0.98	6.44	44.55	935.33	40.58
24	3.13	0.51	37.57	1.02	6.25	44.83	890.78	40.50
23	3.17	0.52	37.99	1.04	6.07	45.10	845.94	40.42
22	3.20	0.54	38.39	1.08	5.89	45.37	800.84	40.33
21	3.23	0.54	38.77	1.08	5.74	45.59	755.48	40.25
20	3.26	0.56	39.14	1.12	5.58	45.84	709.88	40.17
19	3.29	0.57	39.48	1.14	5.43	46.06	664.05	40.08
18	3.32	0.58	39.82	1.16	5.29	46.27	617.99	40.00
17	3.34	0.58	40.13	1.16	5.17	46.46	571.72	39.92
16	3.37	0.60	40.42	1.20	5.03	46.66	525.27	39.83
15	3.39	0.60	40.71	1.20	4.92	46.83	478.61	39.75
14	3.41	0.61	40.97	1.22	4.80	47.00	431.78	39.67
13	3.44	0.61	41.24	1.22	4.70	47.16	384.78	39.58
12	3.46	0.62	41.49	1.24	4.59	47.32	337.62	39.50
11	3.48	0.63	41.74	1.26	4.48	47.48	290.30	39.42
10	3.51	0.63	42.06	1.26	4.35	47.67	242.82	39.33
9	0.00	0.00	0.00	0.00	21.68	21.68	195.14	39.25
8	0.00	0.00	0.00	0.00	21.68	21.68	173.46	39.17
7	0.00	0.00	0.00	0.00	21.68	21.68	151.78	39.08
6	0.00	0.00	0.00	0.00	21.68	21.68	130.09	39.00
5	0.00	0.00	0.00	0.00	21.68	21.68	108.41	38.92
4	0.00	0.00	0.00	0.00	21.68	21.68	86.73	38.83
3	0.00	0.00	0.00	0.00	21.68	21.68	65.05	38.75
2	0.00	0.00	0.00	0.00	21.68	21.68	43.36	38.67
1	0.00	0.00	0.00	0.00	21.68	21.68	21.68	38.58

Copy of the SSD Table in "Cumulative Volumes Imperial" worksheet					42.9 (sq-ft), Bottom Area of 1 Chamber			
Copy this SSD Table to a CSV file to be entered into WWHM					7.5 (sq-ft), Bottom Area of 1 End Cap			
Stage (ft)	Area (ac)	Storage (ac-ft)	Discharge (cfs)	Infiltration (cfs)	Notes			
0.000000	0.000000	0.000000	0.000000	0.000000	Bottom of 9" gravel bedding			
0.083333	0.012163	0.000498	0.000000	0.122639	<table border="1"> <tr> <td>12 Number of Chambers</td> </tr> <tr> <td>2 Number of End Caps</td> </tr> <tr> <td>529.8 (sq-ft), Total Bottom Area for infiltration</td> </tr> </table>	12 Number of Chambers	2 Number of End Caps	529.8 (sq-ft), Total Bottom Area for infiltration
12 Number of Chambers								
2 Number of End Caps								
529.8 (sq-ft), Total Bottom Area for infiltration								
0.166667	0.012163	0.000996	0.000000	0.122639				
0.250000	0.012163	0.001493	0.000000	0.122639				
0.333333	0.012163	0.001991	0.000000	0.122639				
0.416667	0.012163	0.002489	0.000000	0.122639				
0.500000	0.012163	0.002987	0.000000	0.122639				
0.583333	0.012163	0.003484	0.000000	0.122639	Bottom of StormTech Chamber			
0.666667	0.012163	0.003982	0.000000	0.122639				
0.750000	0.012163	0.004480	0.000000	0.122639	<table border="1"> <tr> <td>10 Design Infiltration Rate (in/hr)</td> </tr> <tr> <td>0.000231 Design Infiltration Rate (ft/sec)</td> </tr> <tr> <td>0.122639 (cfs) Facility Infiltration at each stage</td> </tr> </table>	10 Design Infiltration Rate (in/hr)	0.000231 Design Infiltration Rate (ft/sec)	0.122639 (cfs) Facility Infiltration at each stage
10 Design Infiltration Rate (in/hr)								
0.000231 Design Infiltration Rate (ft/sec)								
0.122639 (cfs) Facility Infiltration at each stage								
0.833333	0.012163	0.005574	0.000000	0.122639				
0.916667	0.012163	0.006664	0.000000	0.122639				
1.000000	0.012163	0.007751	0.000000	0.122639				
1.083333	0.012163	0.008833	0.000000	0.122639				
1.166667	0.012163	0.009912	0.000000	0.122639				
1.250000	0.012163	0.010987	0.000000	0.122639				
1.333333	0.012163	0.012058	0.000000	0.122639				
1.416667	0.012163	0.013125	0.000000	0.122639				
1.500000	0.012163	0.014187	0.000000	0.122639				
1.583333	0.012163	0.015244	0.000000	0.122639				
1.666667	0.012163	0.016297	0.000000	0.122639				
1.750000	0.012163	0.017343	0.000000	0.122639				
1.833333	0.012163	0.018385	0.000000	0.122639				
1.916667	0.012163	0.019420	0.000000	0.122639				
2.000000	0.012163	0.020449	0.000000	0.122639				
2.083333	0.012163	0.021472	0.000000	0.122639				
2.166667	0.012163	0.022488	0.000000	0.122639				
2.250000	0.012163	0.023496	0.000000	0.122639				
2.333333	0.012163	0.024497	0.000000	0.122639				
2.416667	0.012163	0.025490	0.000000	0.122639				
2.500000	0.012163	0.026474	0.000000	0.122639				
2.583333	0.012163	0.027450	0.000000	0.122639				
2.666667	0.012163	0.028416	0.000000	0.122639				
2.750000	0.012163	0.029372	0.000000	0.122639				
2.833333	0.012163	0.030318	0.000000	0.122639				
2.916667	0.012163	0.031253	0.000000	0.122639				
3.000000	0.012163	0.032177	0.000000	0.122639				

3.083333	0.012163	0.033088	0.000000	0.122639	
3.166667	0.012163	0.033988	0.000000	0.122639	
3.250000	0.012163	0.034873	0.000000	0.122639	
3.333333	0.012163	0.035744	0.000000	0.122639	
3.416667	0.012163	0.036600	0.000000	0.122639	
3.500000	0.012163	0.037441	0.000000	0.122639	
3.583333	0.012163	0.038263	0.000000	0.122639	
3.666667	0.012163	0.039067	0.000000	0.122639	
3.750000	0.012163	0.039850	0.000000	0.122639	
3.833333	0.012163	0.040611	0.000000	0.122639	
3.916667	0.012163	0.041346	0.000000	0.122639	
4.000000	0.012163	0.042052	0.000000	0.122639	
4.083333	0.012163	0.042721	0.000000	0.122639	
4.166667	0.012163	0.043334	0.000000	0.122639	
4.250000	0.012163	0.043899	0.000000	0.122639	
4.333333	0.012163	0.044445	0.000000	0.122639	
4.416667	0.012163	0.044975	0.000000	0.122639	
4.500000	0.012163	0.045483	0.000000	0.122639	Top of StormTech Chamber
4.583333	0.012163	0.045981	0.037960	0.122639	
4.666667	0.012163	0.046478	0.149186	0.122639	
4.750000	0.012163	0.046976	0.329563	0.122639	
4.833333	0.012163	0.047474	0.574784	0.122639	
4.916667	0.012163	0.047972	0.880321	0.122639	
5.000000	0.012163	0.048469	1.241392	0.122639	
5.083333	0.012163	0.048967	1.652924	0.122639	
5.166667	0.012163	0.049465	2.109495	0.122639	
5.250000	0.012163	0.049963	2.605267	0.122639	
5.333333	0.012163	0.050460	3.133898	0.122639	
5.416667	0.012163	0.050958	3.688412	0.122639	
5.500000	0.012163	0.051456	4.261012	0.122639	Top of 12" of gravel placed over StormTech Chamber

WWHM2012  
PROJECT REPORT

---

**Project Name:** TDAExemptOutwashS  
**Site Name:** ELST - South of SE 8th (Outwash Soil)  
**Site Address:** S. Sam B  
**City** : Sammamish  
**Report Date:** 8/16/2016  
**Gage** : Seatac  
**Data Start** : 1948/10/01 00:00  
**Data End** : 2009/09/30 00:00  
**Precip Scale:** 1.17  
**Version Date:** 2016/05/12  
**Version** : 4.2.12  
**Timestep** : 1-hour

---

**Low Flow Threshold for POC 1** : 50 Percent of the 2 Year

---

**High Flow Threshold for POC 1:** 50 year

---

**PREDEVELOPED LAND USE**

**Name** : Basin 1  
**Bypass:** No

**GroundWater:** No

<u>Pervious Land Use</u>	<u>acre</u>
A B, Forest, Flat	.17
<b>Pervious Total</b>	<b>0.17</b>
<u>Impervious Land Use</u>	<u>acre</u>
<b>Impervious Total</b>	<b>0</b>
<b>Basin Total</b>	<b>0.17</b>

---

**Element Flows To:**

<b>Surface</b>	<b>Interflow</b>	<b>Groundwater</b>
----------------	------------------	--------------------

---

**MITIGATED LAND USE**

**Name** : Basin 1  
**Bypass:** No

**GroundWater:** No



<u>Pervious Land Use</u>	<u>acre</u>
Pervious Total	0
<u>Impervious Land Use</u>	<u>acre</u>
SIDEWALKS FLAT	0.17
Impervious Total	0.17
Basin Total	0.17

Element Flows To:		
Surface	Interflow	Groundwater

**ANALYSIS RESULTS**

Predeveloped Landuse Totals for POC #1  
 Total Pervious Area:0.17  
 Total Impervious Area:0

Mitigated Landuse Totals for POC #1  
 Total Pervious Area:0  
 Total Impervious Area:0.17

Flow Frequency Return Periods for Predeveloped. POC #1

<u>Return Period</u>	<u>Flow(cfs)</u>	
2 year	0.000049	
5 year	0.000151	
10 year	0.0003	
25 year	0.000673	
50 year	0.001184	
100 year	0.002028	β 100-year predeveloped

Flow Frequency Return Periods for Mitigated. POC #1

<u>Return Period</u>	<u>Flow(cfs)</u>	
2 year	0.051457	
5 year	0.064528	
10 year	0.07354	
25 year	0.085365	
50 year	0.094507	
100 year	0.103946	β 100-year developed

**PerlnD and Implnd Changes**  
 No changes have been made.

Increase in 100-year flow no greater than 0.1 cfs; therefore, no flow control facility is required.

WWHM2012  
PROJECT REPORT

---

**Project Name:** TDAExemptTills  
**Site Name:** ELST - South of SE 8th (Till Soil)  
**Site Address:** S. Sam B  
**City** : Sammamish  
**Report Date:** 8/16/2016  
**Gage** : Seatac  
**Data Start** : 1948/10/01 00:00  
**Data End** : 2009/09/30 00:00  
**Precip Scale:** 1.17  
**Version Date:** 2016/05/12  
**Version** : 4.2.12  
**Timestep** : 1-hour

---

**Low Flow Threshold for POC 1** : 50 Percent of the 2 Year

---

**High Flow Threshold for POC 1:** 50 year

---

**PREDEVELOPED LAND USE**

**Name** : Basin 1  
**Bypass:** No

**GroundWater:** No

<u>Pervious Land Use</u>	<u>acre</u>
C, Forest, Flat	.2

Pervious Total	0.2
----------------	-----

<u>Impervious Land Use</u>	<u>acre</u>
----------------------------	-------------

Impervious Total	0
------------------	---

Basin Total	0.2
-------------	-----

---

<b>Element Flows To:</b>		
Surface	Interflow	Groundwater

---

**MITIGATED LAND USE**

**Name** : Basin 1  
**Bypass:** No

**GroundWater:** No

<u>Pervious Land Use</u>	<u>acre</u>
Pervious Total	0
<u>Impervious Land Use</u>	<u>acre</u>
SIDEWALKS FLAT	0.2
Impervious Total	0.2
Basin Total	0.2

Element Flows To:		
Surface	Interflow	Groundwater

ANALYSIS RESULTS

Predeveloped Landuse Totals for POC #1  
Total Pervious Area:0.2  
Total Impervious Area:0

Mitigated Landuse Totals for POC #1  
Total Pervious Area:0  
Total Impervious Area:0.2

Flow Frequency Return Periods for Predeveloped. POC #1

<u>Return Period</u>	<u>Flow(cfs)</u>	
2 year	0.007118	
5 year	0.011358	
10 year	0.014114	
25 year	0.017451	
50 year	0.019809	
100 year	0.022052	β 100-year predeveloped

Flow Frequency Return Periods for Mitigated. POC #1

<u>Return Period</u>	<u>Flow(cfs)</u>	
2 year	0.060538	
5 year	0.075915	
10 year	0.086518	
25 year	0.100429	
50 year	0.111184	
100 year	0.122289	β 100-year developed

PerlnD and Implnd Changes

No changes have been made.

Increase in 100-year flow no greater than 0.1 cfs; therefore, no flow control facility is required.

WWHM2012  
PROJECT REPORT

---

**Project Name:** TDAExemptOutwashN  
**Site Name:** ELST - North of SE 8th (Outwash Soil)  
**Site Address:** S. Sam B  
**City** : Sammamish  
**Report Date:** 8/16/2016  
**Gage** : Seatac  
**Data Start** : 1948/10/01 00:00  
**Data End** : 2009/09/30 00:00  
**Precip Scale:** 1.00  
**Version Date:** 2016/05/12  
**Version** : 4.2.12  
**Timestep** : 1-hour

---

**Low Flow Threshold for POC 1** : 50 Percent of the 2 Year

---

**High Flow Threshold for POC 1:** 50 year

---

**PREDEVELOPED LAND USE**

**Name** : Basin 1  
**Bypass:** No

**GroundWater:** No

<u>Pervious Land Use</u>	<u>acre</u>
A B, Forest, Flat	.19
<b>Pervious Total</b>	<b>0.19</b>
<u>Impervious Land Use</u>	<u>acre</u>
<b>Impervious Total</b>	<b>0</b>
<b>Basin Total</b>	<b>0.19</b>

---

**Element Flows To:**

Surface	Interflow	Groundwater
---------	-----------	-------------

---

**MITIGATED LAND USE**

**Name** : Basin 1  
**Bypass:** No

**GroundWater:** No



<u>Pervious Land Use</u>	<u>acre</u>
Pervious Total	0
<u>Impervious Land Use</u>	<u>acre</u>
SIDEWALKS FLAT	0.19
Impervious Total	0.19
Basin Total	0.19

Element Flows To:		
Surface	Interflow	Groundwater

ANALYSIS RESULTS

Predeveloped Landuse Totals for POC #1  
 Total Pervious Area:0.19  
 Total Impervious Area:0

Mitigated Landuse Totals for POC #1  
 Total Pervious Area:0  
 Total Impervious Area:0.19

Flow Frequency Return Periods for Predeveloped. POC #1

<u>Return Period</u>	<u>Flow(cfs)</u>	
2 year	0.00004	
5 year	0.000064	
10 year	0.000084	
25 year	0.000114	
50 year	0.00014	
100 year	0.00017	β 100-year predeveloped

Flow Frequency Return Periods for Mitigated. POC #1

<u>Return Period</u>	<u>Flow(cfs)</u>	
2 year	0.048588	
5 year	0.060963	
10 year	0.069499	
25 year	0.080703	
50 year	0.089368	
100 year	0.098317	β 100-year developed

PerlnD and Implnd Changes  
 No changes have been made.

Increase in 100-year flow is less than 0.1 cfs; therefore, no flow control facility is required.

WWHM2012  
PROJECT REPORT

---

Project Name: TDAExemptTillN  
Site Name: ELST - North of SE 8th (Till Soil)  
Site Address: S. Sam B  
City : Sammamish  
Report Date: 8/16/2016  
Gage : Seatac  
Data Start : 1948/10/01 00:00  
Data End : 2009/09/30 00:00  
Precip Scale: 1.00  
Version Date: 2016/05/12  
Version : 4.2.12  
Timestep : 1-hour

---

Low Flow Threshold for POC 1 : 50 Percent of the 2 Year

---

High Flow Threshold for POC 1: 50 year

---

PREDEVELOPED LAND USE

Name : Basin 1  
Bypass: No

GroundWater: No

<u>Pervious Land Use</u>	<u>acre</u>
C, Forest, Flat	.21
Pervious Total	0.21
<u>Impervious Land Use</u>	<u>acre</u>
Impervious Total	0
Basin Total	0.21

---

Element Flows To:  
Surface                      Interflow                      Groundwater

---

MITIGATED LAND USE

Name : Basin 1  
Bypass: No

GroundWater: No

<u>Pervious Land Use</u>	<u>acre</u>
Pervious Total	0
<u>Impervious Land Use</u>	<u>acre</u>
SIDEWALKS FLAT	0.21
Impervious Total	0.21
Basin Total	0.21

Element Flows To:		
Surface	Interflow	Groundwater

ANALYSIS RESULTS

Predeveloped Landuse Totals for POC #1  
 Total Pervious Area:0.21  
 Total Impervious Area:0

Mitigated Landuse Totals for POC #1  
 Total Pervious Area:0  
 Total Impervious Area:0.21

Flow Frequency Return Periods for Predeveloped. POC #1

<u>Return Period</u>	<u>Flow(cfs)</u>	
2 year	0.005536	
5 year	0.008907	
10 year	0.010781	
25 year	0.012711	
50 year	0.013869	
100 year	0.014826	β 100-year predeveloped

Flow Frequency Return Periods for Mitigated. POC #1

<u>Return Period</u>	<u>Flow(cfs)</u>	
2 year	0.053702	
5 year	0.06738	
10 year	0.076815	
25 year	0.089198	
50 year	0.098775	
100 year	0.108666	β 100-year developed

PerlnD and Implnd Changes  
 No changes have been made.

Increase in 100-year flow is less than 0.1 cfs; therefore, no flow control facility is required.

WWHM2012  
PROJECT REPORT

---

**Project Name:** TDAs11-12-InfilChamber  
**Site Name:** TDAs 11 and 12  
**Site Address:** Station 288+00  
**City** : Sammamish  
**Report Date:** 8/17/2016  
**Gage** : Seatac  
**Data Start** : 1948/10/01  
**Data End** : 2009/09/30  
**Precip Scale:** 1.17  
**Version Date:** 2016/05/12  
**Version** : 4.2.12

**Timestep** : 1-hour

---

**Low Flow Threshold for POC 1** : 50 Percent of the 2 Year

---

**High Flow Threshold for POC 1:** 50 year

---

**PREDEVELOPED LAND USE**

**Name** : TDA 11  
**Bypass:** No

**GroundWater:** No

<u>Pervious Land Use</u>	<u>acre</u>
A B, Forest, Flat	.32
<b>Pervious Total</b>	<b>0.32</b>
<u>Impervious Land Use</u>	<u>acre</u>
<b>Impervious Total</b>	<b>0</b>
<b>Basin Total</b>	<b>0.32</b>

---

**Element Flows To:**

<b>Surface</b>	<b>Interflow</b>	<b>Groundwater</b>
----------------	------------------	--------------------

---

**Name** : TDA 12  
**Bypass:** No

**GroundWater:** No



<u>Pervious Land Use</u>	<u>acre</u>
A B, Forest, Flat	.18
Pervious Total	0.18
<u>Impervious Land Use</u>	<u>acre</u>
Impervious Total	0
Basin Total	0.18

---

Element Flows To:		
Surface	Interflow	Groundwater

---

MITIGATED LAND USE

Name : TDA 11  
 Bypass: No

GroundWater: No

<u>Pervious Land Use</u>	<u>acre</u>
Pervious Total	0
<u>Impervious Land Use</u>	<u>acre</u>
SIDEWALKS FLAT	0.32
Impervious Total	0.32
Basin Total	0.32

---

Element Flows To:		
Surface	Interflow	Groundwater
StormTech MC3500 - SSDStormTech MC3500 - SSD		

---

Name : TDA 12  
 Bypass: No

GroundWater: No

<u>Pervious Land Use</u>	<u>acre</u>
Pervious Total	0
<u>Impervious Land Use</u>	<u>acre</u>



2.417	0.012	0.025	0.000	0.123	0.000	0.000	0.000
2.500	0.012	0.026	0.000	0.123	0.000	0.000	0.000
2.583	0.012	0.027	0.000	0.123	0.000	0.000	0.000
2.667	0.012	0.028	0.000	0.123	0.000	0.000	0.000
2.750	0.012	0.029	0.000	0.123	0.000	0.000	0.000
2.833	0.012	0.030	0.000	0.123	0.000	0.000	0.000
2.917	0.012	0.031	0.000	0.123	0.000	0.000	0.000
3.000	0.012	0.032	0.000	0.123	0.000	0.000	0.000
3.083	0.012	0.033	0.000	0.123	0.000	0.000	0.000
3.167	0.012	0.034	0.000	0.123	0.000	0.000	0.000
3.250	0.012	0.035	0.000	0.123	0.000	0.000	0.000
3.333	0.012	0.036	0.000	0.123	0.000	0.000	0.000
3.417	0.012	0.037	0.000	0.123	0.000	0.000	0.000
3.500	0.012	0.037	0.000	0.123	0.000	0.000	0.000
3.583	0.012	0.038	0.000	0.123	0.000	0.000	0.000
3.667	0.012	0.039	0.000	0.123	0.000	0.000	0.000
3.750	0.012	0.040	0.000	0.123	0.000	0.000	0.000
3.833	0.012	0.041	0.000	0.123	0.000	0.000	0.000
3.917	0.012	0.041	0.000	0.123	0.000	0.000	0.000
4.000	0.012	0.042	0.000	0.123	0.000	0.000	0.000
4.083	0.012	0.043	0.000	0.123	0.000	0.000	0.000
4.167	0.012	0.043	0.000	0.123	0.000	0.000	0.000
4.250	0.012	0.044	0.000	0.123	0.000	0.000	0.000
4.333	0.012	0.044	0.000	0.123	0.000	0.000	0.000
4.417	0.012	0.045	0.000	0.123	0.000	0.000	0.000
4.500	0.012	0.045	0.000	0.123	0.000	0.000	0.000
4.583	0.012	0.046	0.382	0.123	0.000	0.000	0.000
4.667	0.012	0.046	1.074	0.123	0.000	0.000	0.000
4.750	0.012	0.047	1.938	0.123	0.000	0.000	0.000
4.833	0.012	0.047	2.883	0.123	0.000	0.000	0.000
4.917	0.012	0.048	3.813	0.123	0.000	0.000	0.000
5.000	0.012	0.048	4.639	0.123	0.000	0.000	0.000
5.083	0.012	0.049	5.294	0.123	0.000	0.000	0.000
5.167	0.012	0.049	5.754	0.123	0.000	0.000	0.000
5.250	0.012	0.050	6.072	0.123	0.000	0.000	0.000
5.333	0.012	0.050	6.469	0.123	0.000	0.000	0.000
5.417	0.012	0.051	6.785	0.123	0.000	0.000	0.000
5.500	0.012	0.051	7.087	0.123	0.000	0.000	0.000

---



---

**ANALYSIS RESULTS**

**Stream Protection Duration**

---

**Predeveloped Landuse Totals for POC #1**  
**Total Pervious Area:0.5**  
**Total Impervious Area:0**

---

**Mitigated Landuse Totals for POC #1**  
**Total Pervious Area:0**  
**Total Impervious Area:0.5**

---

**Flow Frequency Return Periods for Predeveloped. POC #1**

<u>Return Period</u>	<u>Flow(cfs)</u>
2 year	0.000145
5 year	0.000446
10 year	0.000883
25 year	0.001979
50 year	0.003482
100 year	0.005964

**Flow Frequency Return Periods for Mitigated. POC #1**

<u>Return Period</u>	<u>Flow(cfs)</u>
2 year	0
5 year	0
10 year	0
25 year	0
50 year	0
100 year	0

---

**Stream Protection Duration**

**Annual Peaks for Predeveloped and Mitigated. POC #1**

<u>Year</u>	<u>Predeveloped</u>	<u>Mitigated</u>
1949	0.000	0.000
1950	0.006	0.000
1951	0.003	0.000
1952	0.000	0.000
1953	0.000	0.000
1954	0.000	0.000
1955	0.000	0.000
1956	0.000	0.000
1957	0.000	0.000
1958	0.000	0.000
1959	0.000	0.000
1960	0.000	0.000
1961	0.000	0.000
1962	0.000	0.000
1963	0.000	0.000
1964	0.000	0.000
1965	0.000	0.000
1966	0.000	0.000
1967	0.000	0.000
1968	0.000	0.000
1969	0.000	0.000
1970	0.000	0.000
1971	0.000	0.000
1972	0.003	0.000
1973	0.000	0.000
1974	0.000	0.000
1975	0.000	0.000
1976	0.000	0.000
1977	0.000	0.000
1978	0.000	0.000
1979	0.000	0.000
1980	0.000	0.000
1981	0.000	0.000
1982	0.000	0.000



1983	0.000	0.000
1984	0.000	0.000
1985	0.000	0.000
1986	0.000	0.000
1987	0.000	0.000
1988	0.000	0.000
1989	0.000	0.000
1990	0.000	0.000
1991	0.002	0.000
1992	0.000	0.000
1993	0.000	0.000
1994	0.000	0.000
1995	0.000	0.000
1996	0.004	0.000
1997	0.001	0.000
1998	0.000	0.000
1999	0.000	0.000
2000	0.000	0.000
2001	0.000	0.000
2002	0.000	0.000
2003	0.000	0.000
2004	0.000	0.099
2005	0.000	0.000
2006	0.000	0.000
2007	0.025	0.000
2008	0.000	0.063
2009	0.000	0.000

**Stream Protection Duration**

**Ranked Annual Peaks for Predeveloped and Mitigated. POC #1**

<b>Rank</b>	<b>Predeveloped</b>	<b>Mitigated</b>
1	0.0248	0.0995
2	0.0063	0.0634
3	0.0040	0.0000
4	0.0034	0.0000
5	0.0027	0.0000
6	0.0020	0.0000
7	0.0011	0.0000
8	0.0005	0.0000
9	0.0004	0.0000
10	0.0003	0.0000
11	0.0003	0.0000
12	0.0002	0.0000
13	0.0002	0.0000
14	0.0002	0.0000
15	0.0002	0.0000
16	0.0001	0.0000
17	0.0001	0.0000
18	0.0001	0.0000
19	0.0001	0.0000
20	0.0001	0.0000
21	0.0001	0.0000
22	0.0001	0.0000
23	0.0001	0.0000
24	0.0001	0.0000
25	0.0001	0.0000

26	0.0001	0.0000
27	0.0001	0.0000
28	0.0001	0.0000
29	0.0001	0.0000
30	0.0001	0.0000
31	0.0001	0.0000
32	0.0001	0.0000
33	0.0001	0.0000
34	0.0001	0.0000
35	0.0001	0.0000
36	0.0001	0.0000
37	0.0001	0.0000
38	0.0001	0.0000
39	0.0001	0.0000
40	0.0001	0.0000
41	0.0001	0.0000
42	0.0001	0.0000
43	0.0001	0.0000
44	0.0001	0.0000
45	0.0001	0.0000
46	0.0001	0.0000
47	0.0001	0.0000
48	0.0001	0.0000
49	0.0001	0.0000
50	0.0001	0.0000
51	0.0001	0.0000
52	0.0001	0.0000
53	0.0001	0.0000
54	0.0001	0.0000
55	0.0001	0.0000
56	0.0001	0.0000
57	0.0001	0.0000
58	0.0001	0.0000
59	0.0001	0.0000
60	0.0001	0.0000
61	0.0001	0.0000

**Stream Protection Duration**  
**POC #1**

Facility **FAILED** duration standard for 1+ flows.

Flow(cfs)	Predev	Mit	Percentage	Pass/Fail
0.0001	1462	8	0	Pass
0.0001	246	8	3	Pass
0.0001	198	8	4	Pass
0.0002	163	8	4	Pass
0.0002	145	8	5	Pass
0.0002	133	8	6	Pass
0.0003	119	8	6	Pass
0.0003	108	8	7	Pass
0.0003	94	8	8	Pass
0.0004	83	8	9	Pass
0.0004	80	8	10	Pass
0.0005	75	8	10	Pass
0.0005	65	8	12	Pass

0.0005	63	8	12	Pass
0.0006	60	8	13	Pass
0.0006	58	8	13	Pass
0.0006	52	8	15	Pass
0.0007	49	8	16	Pass
0.0007	48	8	16	Pass
0.0007	48	8	16	Pass
0.0008	47	8	17	Pass
0.0008	46	8	17	Pass
0.0008	44	8	18	Pass
0.0009	44	8	18	Pass
0.0009	39	8	20	Pass
0.0009	37	8	21	Pass
0.0010	37	8	21	Pass
0.0010	36	8	22	Pass
0.0010	35	8	22	Pass
0.0011	33	8	24	Pass
0.0011	30	8	26	Pass
0.0011	27	8	29	Pass
0.0012	27	8	29	Pass
0.0012	27	8	29	Pass
0.0012	26	8	30	Pass
0.0013	26	8	30	Pass
0.0013	24	8	33	Pass
0.0013	24	8	33	Pass
0.0014	22	8	36	Pass
0.0014	22	8	36	Pass
0.0015	22	8	36	Pass
0.0015	22	8	36	Pass
0.0015	21	8	38	Pass
0.0016	20	8	40	Pass
0.0016	20	8	40	Pass
0.0016	20	8	40	Pass
0.0017	20	8	40	Pass
0.0017	19	8	42	Pass
0.0017	19	8	42	Pass
0.0018	19	8	42	Pass
0.0018	19	8	42	Pass
0.0018	17	8	47	Pass
0.0019	16	8	50	Pass
0.0019	16	8	50	Pass
0.0019	16	8	50	Pass
0.0020	15	8	53	Pass
0.0020	15	8	53	Pass
0.0020	14	8	57	Pass
0.0021	13	8	61	Pass
0.0021	13	8	61	Pass
0.0021	13	8	61	Pass
0.0022	13	8	61	Pass
0.0022	13	8	61	Pass
0.0022	13	8	61	Pass
0.0023	13	8	61	Pass
0.0023	12	8	66	Pass
0.0023	11	8	72	Pass
0.0024	11	8	72	Pass
0.0024	11	8	72	Pass
0.0024	10	8	80	Pass

0.0025	9	8	88	Pass
0.0025	9	8	88	Pass
0.0026	9	8	88	Pass
0.0026	9	8	88	Pass
0.0026	9	8	88	Pass
0.0027	9	8	88	Pass
0.0027	7	7	100	Pass
0.0027	7	7	100	Pass
0.0028	7	7	100	Pass
0.0028	7	7	100	Pass
0.0028	7	7	100	Pass
0.0029	7	7	100	Pass
0.0029	7	7	100	Pass
0.0029	7	7	100	Pass
0.0030	7	7	100	Pass
0.0030	7	7	100	Pass
0.0030	6	7	116	Fail
0.0031	6	7	116	Fail
0.0031	6	7	116	Fail
0.0031	6	7	116	Fail
0.0032	6	7	116	Fail
0.0032	6	7	116	Fail
0.0032	6	7	116	Fail
0.0033	6	7	116	Fail
0.0033	6	7	116	Fail
0.0033	6	7	116	Fail
0.0033	6	7	116	Fail
0.0034	6	7	116	Fail
0.0034	6	7	116	Fail
0.0034	5	7	140	Fail
0.0035	5	7	140	Fail

The development has an increase in flow durations from 1/2 Predeveloped 2 year flow to the 2 year flow or more than a 10% increase from the 2 year to the 50 year flow.

Water Quality BMP Flow and Volume for POC #1  
 On-line facility volume: 0 acre-feet  
 On-line facility target flow: 0 cfs.  
 Adjusted for 15 min: 0 cfs.  
 Off-line facility target flow: 0 cfs.  
 Adjusted for 15 min: 0 cfs.

#### LID Report

LID Technique	Water Quality	Used for Percent Treatment?	Total Volumn Comment Needs Treatment (ac-ft)	Volumn Through Facility (ac-ft)	Infiltration Volumn (ac-ft.)	Cumulative Volumn Infiltration Credit
StormTech MC3500 - SSD Table P		N	85.88			N 99.80
Total Volume Infiltrated			85.88	0.00	0.00	
99.80	0.00	0%	No Treat. Credit			
Compliance with LID Standard 8						
Duration Analysis Result = Passed						



---

**Perlnd and Implnd Changes**

No changes have been made.

---

This program and accompanying documentation are provided 'as-is' without warranty of any kind. The entire risk regarding the performance and results of this program is assumed by End User. Clear Creek Solutions Inc. and the governmental licensee or sublicensees disclaim all warranties, either expressed or implied, including but not limited to implied warranties of program and accompanying documentation. In no event shall Clear Creek Solutions Inc. be liable for any damages whatsoever (including without limitation to damages for loss of business profits, loss of business information, business interruption, and the like) arising out of the use of, or inability to use this program even if Clear Creek Solutions Inc. or their authorized representatives have been advised of the possibility of such damages. Software Copyright © by : Clear Creek Solutions, Inc. 2005-2016; All Rights Reserved.

**Project: ELST - SouthSammamish Segment B**



Chamber Model -	MC-3500
Units -	Imperial
Number of Chambers -	12
Number of End Caps -	2
Voids in the stone (porosity) -	40 %
Base of Stone Elevation -	38.50 ft
Amount of Stone Above Chambers -	12 in
Amount of Stone Below Chambers -	9 in

Include Perimeter Stone in Calculations

**StormTech MC-3500 Cumulative Storage Volumes**

Height of System (inches)	Incremental Single Chamber (cubic feet)	Incremental Single End Cap (cubic feet)	Incremental Chambers (cubic feet)	Incremental End Cap (cubic feet)	Incremental Stone (cubic feet)	Incremental Ch, EC and Stone (cubic feet)	Cumulative System (cubic feet)	Elevation (feet)
66	0.00	0.00	0.00	0.00	21.68	21.68	2241.42	44.00
65	0.00	0.00	0.00	0.00	21.68	21.68	2219.74	43.92
64	0.00	0.00	0.00	0.00	21.68	21.68	2198.05	43.83
63	0.00	0.00	0.00	0.00	21.68	21.68	2176.37	43.75
62	0.00	0.00	0.00	0.00	21.68	21.68	2154.69	43.67
61	0.00	0.00	0.00	0.00	21.68	21.68	2133.01	43.58
60	0.00	0.00	0.00	0.00	21.68	21.68	2111.32	43.50
59	0.00	0.00	0.00	0.00	21.68	21.68	2089.64	43.42
58	0.00	0.00	0.00	0.00	21.68	21.68	2067.96	43.33
57	0.00	0.00	0.00	0.00	21.68	21.68	2046.28	43.25
56	0.00	0.00	0.00	0.00	21.68	21.68	2024.60	43.17
55	0.00	0.00	0.00	0.00	21.68	21.68	2002.91	43.08
54	0.06	0.00	0.70	0.00	21.40	22.10	1981.23	43.00
53	0.19	0.01	2.33	0.02	20.74	23.09	1959.13	42.92
52	0.29	0.01	3.53	0.02	20.26	23.81	1936.04	42.83
51	0.40	0.02	4.84	0.04	19.73	24.61	1912.23	42.75
50	0.69	0.04	8.25	0.08	18.35	26.68	1887.62	42.67
49	1.03	0.05	12.34	0.10	16.71	29.15	1860.94	42.58
48	1.25	0.07	14.99	0.14	15.63	30.76	1831.79	42.50
47	1.42	0.09	17.07	0.18	14.78	32.03	1801.03	42.42
46	1.57	0.10	18.88	0.20	14.05	33.13	1769.00	42.33
45	1.71	0.12	20.49	0.24	13.39	34.12	1735.87	42.25
44	1.83	0.14	21.94	0.28	12.79	35.02	1701.75	42.17
43	1.94	0.16	23.25	0.32	12.25	35.83	1666.74	42.08
42	2.04	0.18	24.49	0.36	11.74	36.59	1630.91	42.00
41	2.13	0.20	25.62	0.40	11.28	37.29	1594.32	41.92
40	2.22	0.21	26.69	0.42	10.84	37.95	1557.03	41.83
39	2.31	0.24	27.68	0.48	10.42	38.58	1519.08	41.75
38	2.38	0.26	28.62	0.52	10.03	39.16	1480.50	41.67
37	2.46	0.27	29.51	0.54	9.66	39.71	1441.33	41.58
36	2.53	0.29	30.34	0.58	9.32	40.23	1401.62	41.50
35	2.59	0.32	31.12	0.64	8.98	40.74	1361.39	41.42
34	2.66	0.33	31.87	0.66	8.67	41.20	1320.65	41.33
33	2.72	0.35	32.58	0.70	8.37	41.65	1279.44	41.25
32	2.77	0.37	33.26	0.74	8.08	42.08	1237.79	41.17
31	2.82	0.39	33.90	0.78	7.81	42.49	1195.71	41.08
30	2.88	0.41	34.51	0.82	7.55	42.88	1153.23	41.00
29	2.92	0.43	35.09	0.86	7.30	43.25	1110.35	40.92
28	2.97	0.45	35.64	0.90	7.07	43.61	1067.10	40.83
27	3.01	0.46	36.15	0.92	6.85	43.92	1023.49	40.75
26	3.05	0.48	36.64	0.96	6.64	44.24	979.57	40.67
25	3.09	0.49	37.13	0.98	6.44	44.55	935.33	40.58
24	3.13	0.51	37.57	1.02	6.25	44.83	890.78	40.50
23	3.17	0.52	37.99	1.04	6.07	45.10	845.94	40.42
22	3.20	0.54	38.39	1.08	5.89	45.37	800.84	40.33
21	3.23	0.54	38.77	1.08	5.74	45.59	755.48	40.25
20	3.26	0.56	39.14	1.12	5.58	45.84	709.88	40.17
19	3.29	0.57	39.48	1.14	5.43	46.06	664.05	40.08
18	3.32	0.58	39.82	1.16	5.29	46.27	617.99	40.00
17	3.34	0.58	40.13	1.16	5.17	46.46	571.72	39.92
16	3.37	0.60	40.42	1.20	5.03	46.66	525.27	39.83
15	3.39	0.60	40.71	1.20	4.92	46.83	478.61	39.75
14	3.41	0.61	40.97	1.22	4.80	47.00	431.78	39.67
13	3.44	0.61	41.24	1.22	4.70	47.16	384.78	39.58
12	3.46	0.62	41.49	1.24	4.59	47.32	337.62	39.50
11	3.48	0.63	41.74	1.26	4.48	47.48	290.30	39.42
10	3.51	0.63	42.06	1.26	4.35	47.67	242.82	39.33
9	0.00	0.00	0.00	0.00	21.68	21.68	195.14	39.25
8	0.00	0.00	0.00	0.00	21.68	21.68	173.46	39.17
7	0.00	0.00	0.00	0.00	21.68	21.68	151.78	39.08
6	0.00	0.00	0.00	0.00	21.68	21.68	130.09	39.00
5	0.00	0.00	0.00	0.00	21.68	21.68	108.41	38.92
4	0.00	0.00	0.00	0.00	21.68	21.68	86.73	38.83
3	0.00	0.00	0.00	0.00	21.68	21.68	65.05	38.75
2	0.00	0.00	0.00	0.00	21.68	21.68	43.36	38.67
1	0.00	0.00	0.00	0.00	21.68	21.68	21.68	38.58

Copy of the SSD Table in "Cumulative Volumes Imperial" worksheet					42.9 (sq-ft), Bottom Area of 1 Chamber			
Copy this SSD Table to a CSV file to be entered into WWHM					7.5 (sq-ft), Bottom Area of 1 End Cap			
Stage (ft)	Area (ac)	Storage (ac-ft)	Discharge (cfs)	Infiltration (cfs)	Notes			
0.000000	0.000000	0.000000	0.000000	0.000000	Bottom of 9" gravel bedding			
0.083333	0.012163	0.000498	0.000000	0.122639	<table border="1"> <tr> <td>12 Number of Chambers</td> </tr> <tr> <td>2 Number of End Caps</td> </tr> <tr> <td>529.8 (sq-ft), Total Bottom Area for infiltration</td> </tr> </table>	12 Number of Chambers	2 Number of End Caps	529.8 (sq-ft), Total Bottom Area for infiltration
12 Number of Chambers								
2 Number of End Caps								
529.8 (sq-ft), Total Bottom Area for infiltration								
0.166667	0.012163	0.000996	0.000000	0.122639				
0.250000	0.012163	0.001493	0.000000	0.122639				
0.333333	0.012163	0.001991	0.000000	0.122639				
0.416667	0.012163	0.002489	0.000000	0.122639				
0.500000	0.012163	0.002987	0.000000	0.122639				
0.583333	0.012163	0.003484	0.000000	0.122639	<table border="1"> <tr> <td>10 Design Infiltration Rate (in/hr)</td> </tr> <tr> <td>0.000231 Design Infiltration Rate (ft/sec)</td> </tr> <tr> <td>0.122639 (cfs) Facility Infiltration at each stage</td> </tr> </table>	10 Design Infiltration Rate (in/hr)	0.000231 Design Infiltration Rate (ft/sec)	0.122639 (cfs) Facility Infiltration at each stage
10 Design Infiltration Rate (in/hr)								
0.000231 Design Infiltration Rate (ft/sec)								
0.122639 (cfs) Facility Infiltration at each stage								
0.666667	0.012163	0.003982	0.000000	0.122639				
0.750000	0.012163	0.004480	0.000000	0.122639				
0.833333	0.012163	0.005574	0.000000	0.122639				
0.916667	0.012163	0.006664	0.000000	0.122639				
1.000000	0.012163	0.007751	0.000000	0.122639				
1.083333	0.012163	0.008833	0.000000	0.122639				
1.166667	0.012163	0.009912	0.000000	0.122639				
1.250000	0.012163	0.010987	0.000000	0.122639				
1.333333	0.012163	0.012058	0.000000	0.122639				
1.416667	0.012163	0.013125	0.000000	0.122639				
1.500000	0.012163	0.014187	0.000000	0.122639				
1.583333	0.012163	0.015244	0.000000	0.122639				
1.666667	0.012163	0.016297	0.000000	0.122639				
1.750000	0.012163	0.017343	0.000000	0.122639				
1.833333	0.012163	0.018385	0.000000	0.122639				
1.916667	0.012163	0.019420	0.000000	0.122639				
2.000000	0.012163	0.020449	0.000000	0.122639				
2.083333	0.012163	0.021472	0.000000	0.122639				
2.166667	0.012163	0.022488	0.000000	0.122639				
2.250000	0.012163	0.023496	0.000000	0.122639				
2.333333	0.012163	0.024497	0.000000	0.122639				
2.416667	0.012163	0.025490	0.000000	0.122639				
2.500000	0.012163	0.026474	0.000000	0.122639				
2.583333	0.012163	0.027450	0.000000	0.122639				
2.666667	0.012163	0.028416	0.000000	0.122639				
2.750000	0.012163	0.029372	0.000000	0.122639				
2.833333	0.012163	0.030318	0.000000	0.122639				
2.916667	0.012163	0.031253	0.000000	0.122639				
3.000000	0.012163	0.032177	0.000000	0.122639				

3.083333	0.012163	0.033088	0.000000	0.122639	
3.166667	0.012163	0.033988	0.000000	0.122639	
3.250000	0.012163	0.034873	0.000000	0.122639	
3.333333	0.012163	0.035744	0.000000	0.122639	
3.416667	0.012163	0.036600	0.000000	0.122639	
3.500000	0.012163	0.037441	0.000000	0.122639	
3.583333	0.012163	0.038263	0.000000	0.122639	
3.666667	0.012163	0.039067	0.000000	0.122639	
3.750000	0.012163	0.039850	0.000000	0.122639	
3.833333	0.012163	0.040611	0.000000	0.122639	
3.916667	0.012163	0.041346	0.000000	0.122639	
4.000000	0.012163	0.042052	0.000000	0.122639	
4.083333	0.012163	0.042721	0.000000	0.122639	
4.166667	0.012163	0.043334	0.000000	0.122639	
4.250000	0.012163	0.043899	0.000000	0.122639	
4.333333	0.012163	0.044445	0.000000	0.122639	
4.416667	0.012163	0.044975	0.000000	0.122639	
4.500000	0.012163	0.045483	0.000000	0.122639	Top of StormTech Chamber
4.583333	0.012163	0.045981	0.037960	0.122639	
4.666667	0.012163	0.046478	0.149186	0.122639	
4.750000	0.012163	0.046976	0.329563	0.122639	
4.833333	0.012163	0.047474	0.574784	0.122639	
4.916667	0.012163	0.047972	0.880321	0.122639	
5.000000	0.012163	0.048469	1.241392	0.122639	
5.083333	0.012163	0.048967	1.652924	0.122639	
5.166667	0.012163	0.049465	2.109495	0.122639	
5.250000	0.012163	0.049963	2.605267	0.122639	
5.333333	0.012163	0.050460	3.133898	0.122639	
5.416667	0.012163	0.050958	3.688412	0.122639	
5.500000	0.012163	0.051456	4.261012	0.122639	Top of 12" of gravel placed over StormTech Chamber



## C3 – Hydraulic Calculations for Stream Culverts





The corresponding catchment area and creek name with its area are shown in the table below.

*Table 1. Catchment and Creek Names*

Catchment Area	Creek Name	Area (Acres)
STA 378+40 Structure	Pine Lake Creek	1206.0
STA 401+00 Structure	Stream 0155	128.7
Thompson Basin	Ebright Creek	774.1
STA 426+40 Structure	Zaccuse Creek	160.1
Inglewood Basin (STA441+50)	George Davis Creek	1717.9
STA 460+20 Structure	Stream 0143L	100.3

For each catchment area, a land use analysis was done using city zoning and soil type through ArcGIS. ArcGIS defined the area as the following land uses: business services, educational services, finance and insurance service, governmental service, household 2-4 units, household multi, household single, miscellaneous (impervious, church, self-storage), open space, parks, personal, professional residential, retail, undeveloped, utilities, water area, and roads.

Using aerial photography, these areas were more generally defined as the percent impervious and pervious land categories (grass, forest, pasture) used for the remaining percentage. Combining that with the underlying type of soil, each basin was divided into 8 categories to be inputted into MGSFlood: Outwash – Forest, Pasture, and Grass, Till – Forest, Pasture, and Grass, Saturated (soils containing hydrologic group D), and Impervious.

Business Services – 85%, Grass  
 Educational Services – 85%, Grass  
 Finance and Insurance Service – 85%, Grass  
 Governmental Service – 4%, Forest  
 Household 2-4 Units – 10%, Grass  
 Household Multi – 48%, Grass  
 Household Single – 10%, Pasture  
 Miscellaneous (Impervious, Church, Self-Storage) – 85%, Grass  
 Open Space – 4%, 50 Grass/ 50 Pasture  
 Parks – 4%, 50 Grass/ 50 Pasture  
 Personal – 85%, Grass  
 Professional – 85%, Grass  
 Residential – 48%, Grass  
 Retail – 85%, Grass  
 Undeveloped – 0%, Forest  
 Utilities – 4%, Pasture  
 Water Area – 100%  
 Roads – 100%

Table 2. STA 378 + 40 Structure Pine Lake Creek

MGSFlood Inputs		Acres
Outwash (A&B)	Forest	194.6
	Pasture	649.9
	Grass	5.2
Till (C)	Forest	0.9
	Pasture	10.1
	Grass	0.0
(A/D, B/D, C/D)	Saturated	64.2
-	Impervious	293.5

Table 3. STA 401 + 00 Structure Stream 0155

MGSFlood Inputs		Acres
Outwash (A&B)	Forest	41.4
	Pasture	51.8
	Grass	0.0
Till (C)	Forest	5.0
	Pasture	7.0
	Grass	0.0
(A/D, B/D, C/D)	Saturated	7.9
-	Impervious	11.2

Table 4. Thompson Basin (Ebright Creek)

MGSFlood Inputs		Acres
Outwash (A&B)	Forest	134.2
	Pasture	448.8
	Grass	15.3
Till (C)	Forest	0.0
	Pasture	0.0
	Grass	0.0
(A/D, B/D, C/D)	Saturated	36.4
-	Impervious	139.4



Table 5. STA 426 + 40 Structure (Zaccuse Creek)

MGSFlood Inputs		Acres
Outwash (A&B)	Forest	26.5
	Pasture	95.5
	Grass	0.0
Till (C)	Forest	0.0
	Pasture	0.0
	Grass	0.0
(A/D, B/D, C/D)	Saturated	1.2
-	Impervious	36.8

Table 6. Inglewood Basin (George Davis Creek)

MGSFlood Inputs		Acres
Outwash (A&B)	Forest	235.5
	Pasture	852.3
	Grass	83.5
Till (C)	Forest	0.0
	Pasture	0.0
	Grass	0.0
(A/D, B/D, C/D)	Saturated	61.6
-	Impervious	500.3

Table 7. STA 460 + 20 Structure (Stream 0143L)

MGSFlood Inputs		Acres
Outwash (A&B)	Forest	19.0
	Pasture	46.0
	Grass	0.5
Till (C)	Forest	2.3
	Pasture	3.1
	Grass	0.3
(A/D, B/D, C/D)	Saturated	0.0
-	Impervious	29.2

The land uses for each catchment area were inputted into MGSFlood to compute peak flow rates using the 5 minute timestep. The 25-year and the 100-year were entered into the HY-8 program for the culvert analysis.

*Table 8. Pine Lake Creek*

Recurrence (Year)	Discharge (cfs)
2-Year	138.779
5-Year	182.787
10-Year	233.774
25-Year	283.550
50-Year	346.764
100-Year	431.045
200-Year	471.265

*Table 9. Stream 0155*

Recurrence (Year)	Discharge (cfs)
2-Year	6.145
5-Year	80.96
10-Year	10.355
25-Year	14.877
50-Year	17.343
100-Year	20.275
200-Year	22.453

*Table 10. Ebright Creek*

Recurrence (Year)	Discharge (cfs)
2-Year	1.451
5-Year	1.877
10-Year	2.308
25-Year	2.819
50-Year	3.480
100-Year	4.303
200-Year	4.929

*Table 11. Zaccuse Creek*

Recurrence (Year)	Discharge (cfs)
2-Year	18.400
5-Year	23.806
10-Year	29.303
25-Year	35.806
50-Year	44.161
100-Year	54.588
200-Year	62.548

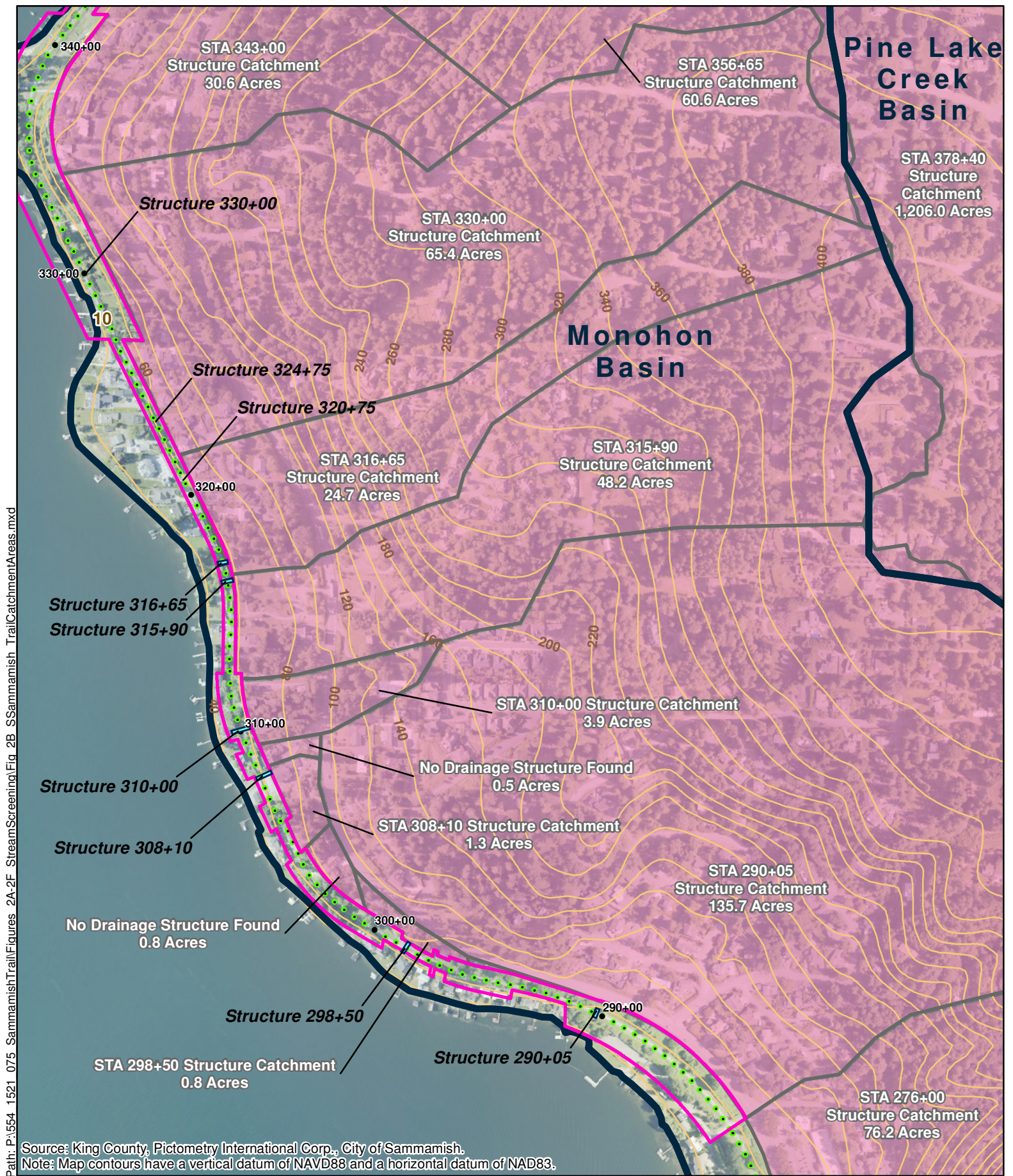
*Table 12. George Davis Creek*

Recurrence (Year)	Discharge (cfs)
2-Year	250.021
5-Year	322.611
10-Year	399.668
25-Year	484.925
50-Year	600.033
100-Year	741.978
200-Year	850.244

*Table 13. Stream 0143L*

Recurrence (Year)	Discharge (cfs)
2-Year	14.675
5-Year	18.962
10-Year	23.797
25-Year	28.688
50-Year	36.506
100-Year	45.145
200-Year	51.393

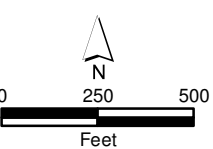




Path: P:\554\_1521\_075\_SammamishTrail\Figures\_2A-2F\_StreamScreening\Fig\_2B\_Sammamish\_Trail\CatchmentAreas.mxd

Source: King County, Pictometry International Corp., City of Sammamish.  
 Note: Map contours have a vertical datum of NAVD88 and a horizontal datum of NAD83.

**Parametrix**

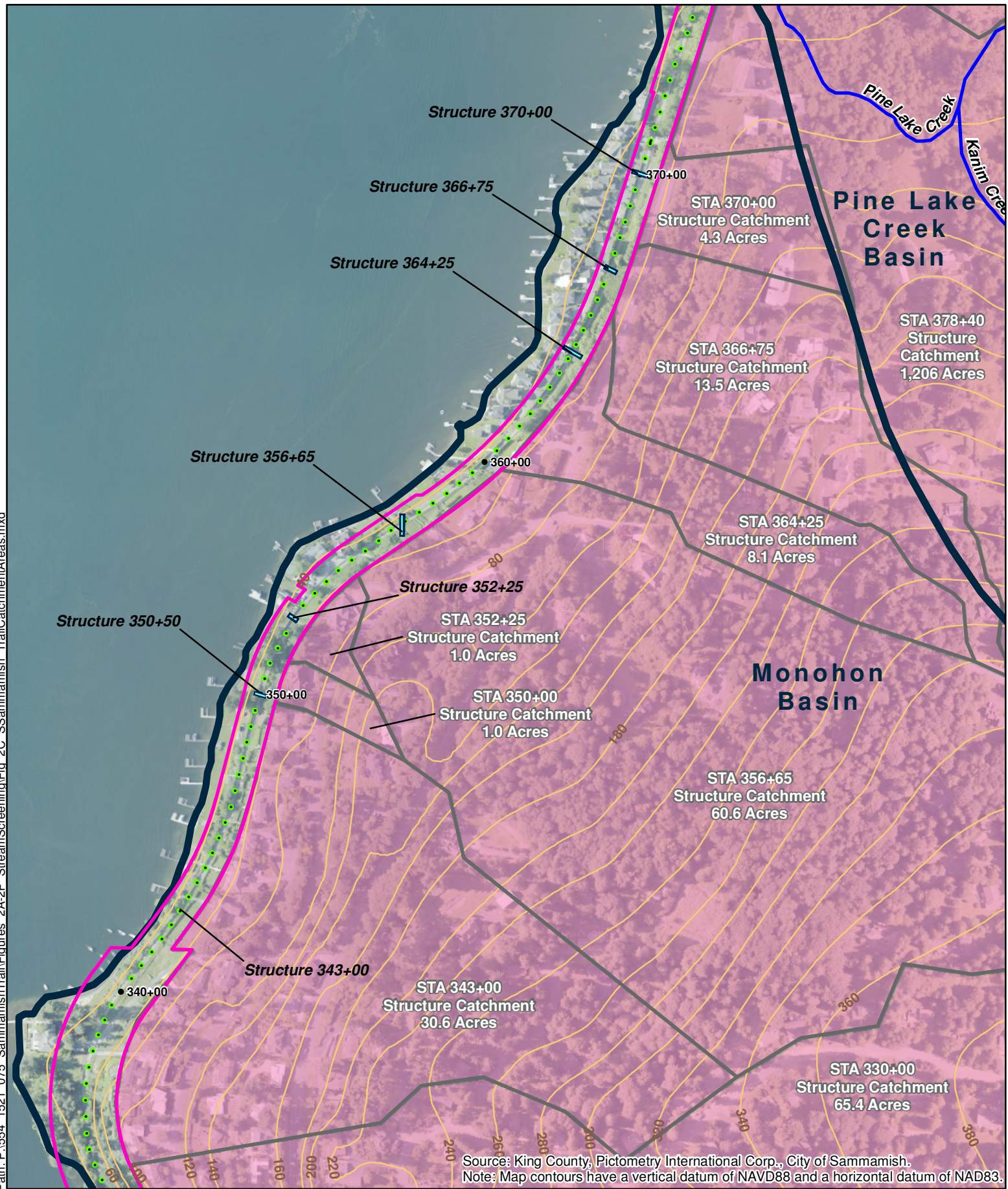


- █ South Sammamish Segment B Project Location
- █ Stream Crossing Field-Verified by Parametrix
- █ Stream Crossing Not Found Within Trail Corridor
- City of Sammamish Drainage Basin
- Catchment Area
- █ Contour - 20ft
- █ Drainage Structure
- Proposed Trail Stationing

**Figure 2B**  
**Trail Drainage Structure**  
**Catchment Areas**

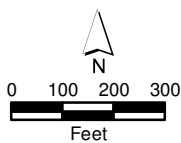


Path: P:\1554\_1521\_075\_SammamishTrail\Figures\_2A-2F\_StreamScreening\Fig\_2C\_SSammamish\_TrailCatchmentAreas.mxd



Source: King County, Pictometry International Corp., City of Sammamish.  
 Note: Map contours have a vertical datum of NAVD88 and a horizontal datum of NAD83.

**Parametrix**

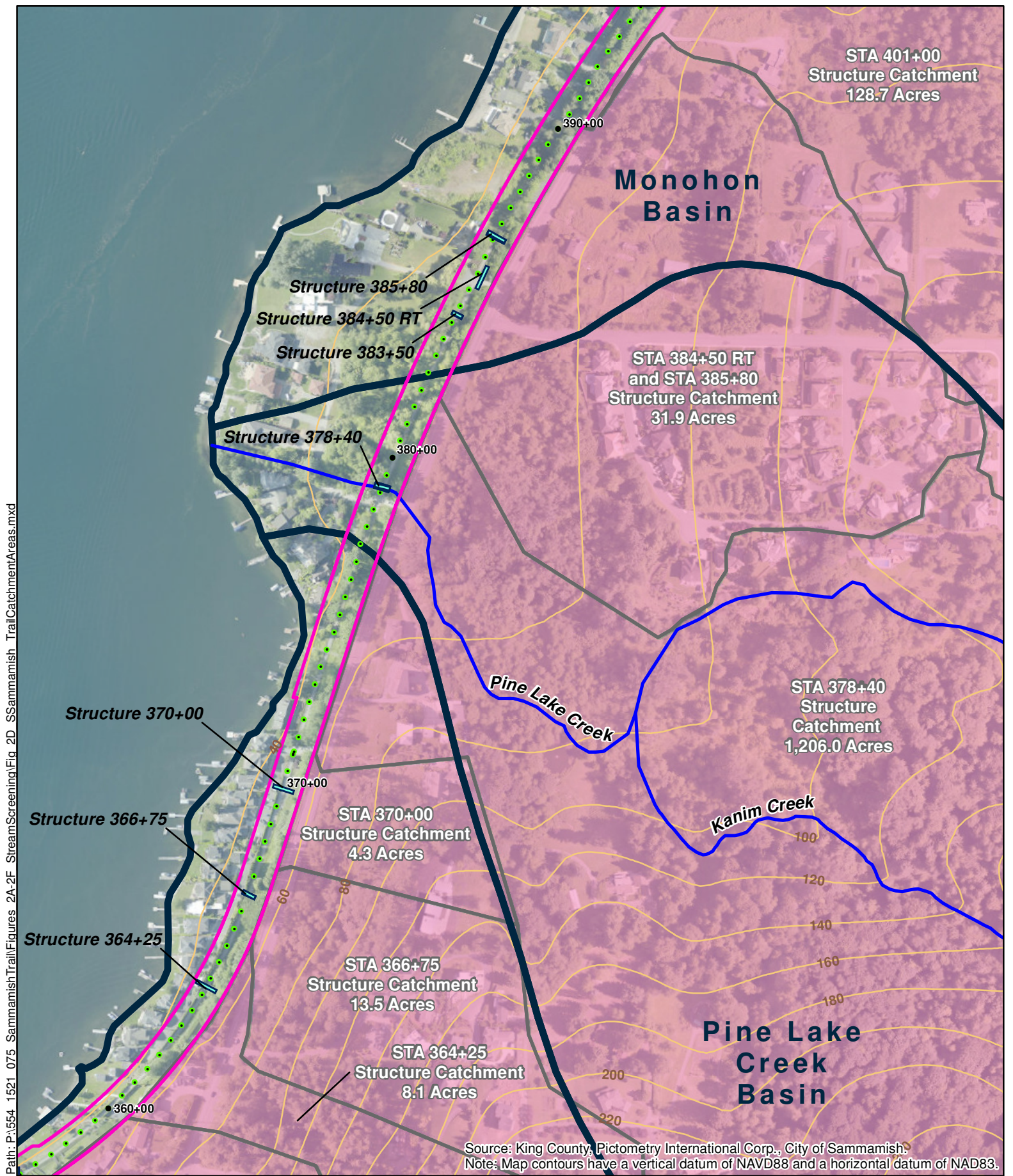


- South Sammamish Segment A Project Location
- Stream Crossing Field-Verified by Parametrix
- Stream Crossing Not Found Within Trail Corridor
- City of Sammamish Drainage Basin
- Catchment Area
- Contour - 20ft
- Drainage Structure



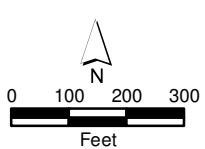
**Figure 2C**  
**Trail Drainage Structure**  
**Catchment Areas**





Path: P:\1554\_1521\_075\_SammamishTrail\Figures\_2A-2F\_StreamScreening\Fig\_2D\_Sammamish\_TrailCatchmentAreas.mxd

**Parametrix**

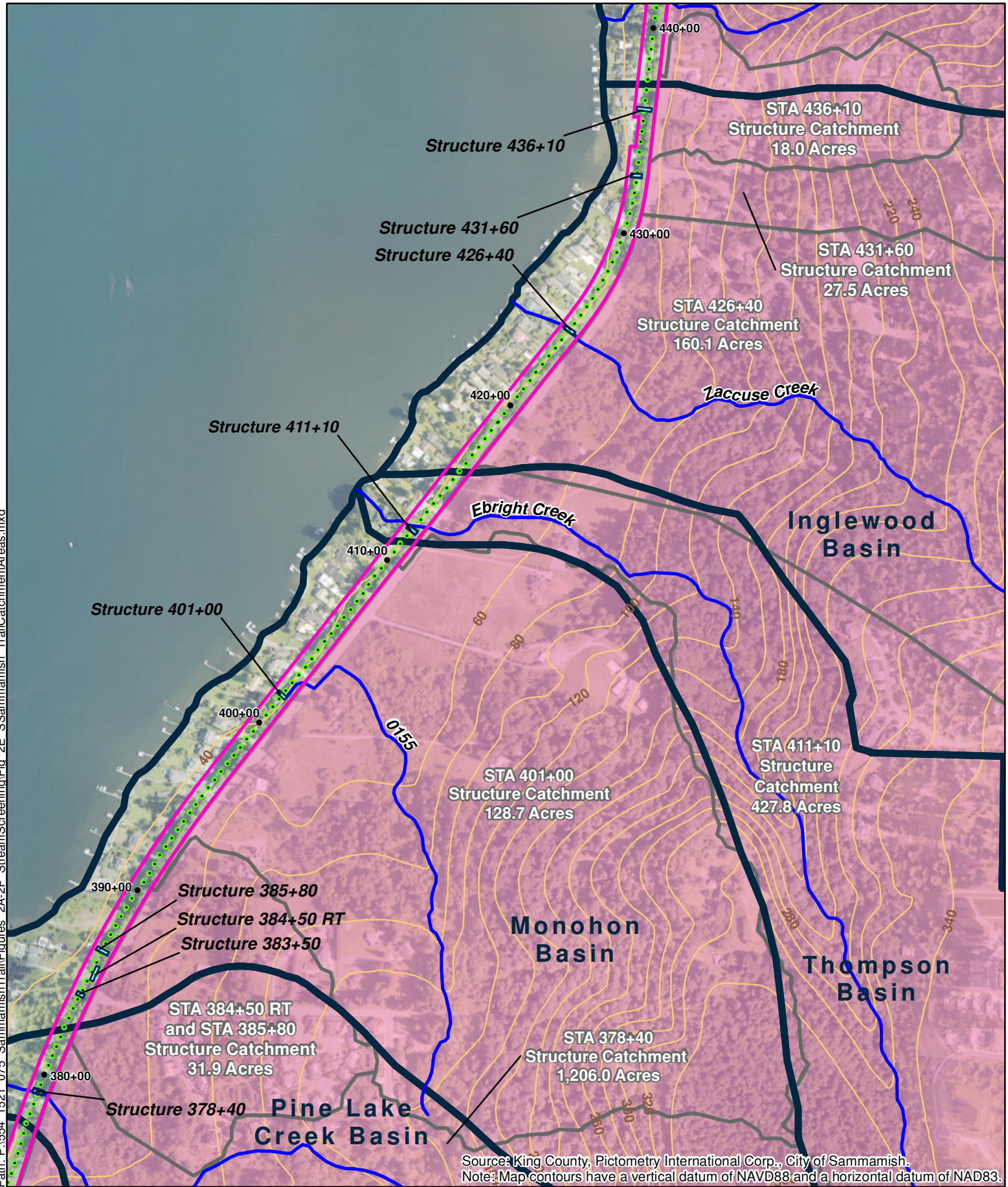


- South Sammamish Segment B Project Location
- Stream Crossing Field-Verified by Parametrix
- Stream Crossing Not Found Within Trail Corridor
- City of Sammamish Drainage Basin
- Catchment Area
- Contour - 20ft
- Drainage Structure
- Proposed Trail Stationing

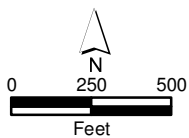
**Figure 2D**  
**Trail Drainage Structure**  
**Catchment Areas**



Path: P:\1554\_1521\_075\_SammamishTrail\Figures\_2A-2F\_StreamScreening\Fig\_2E\_Sammamish\_TrailCatchmentAreas.mxd



**Parametrix**

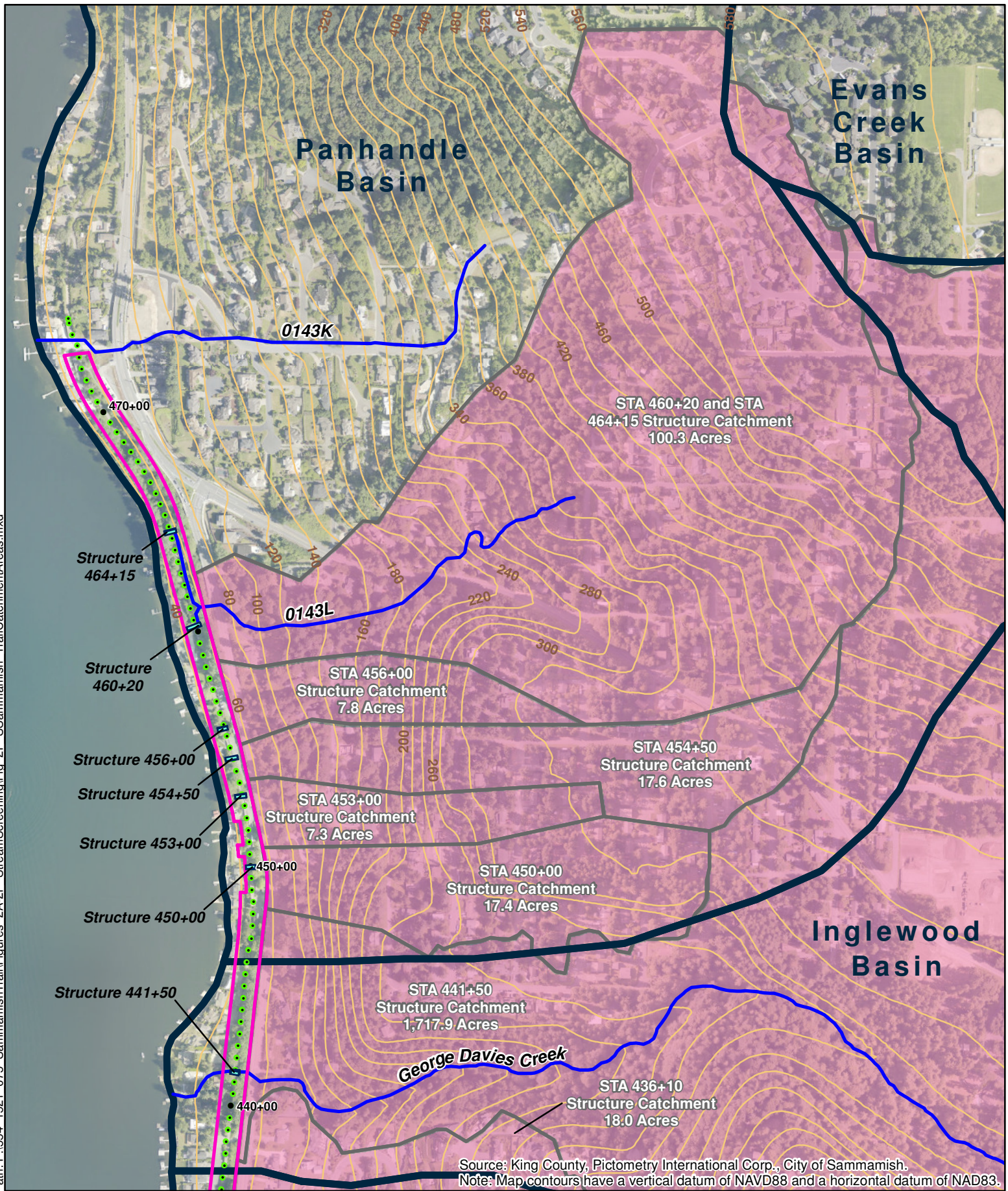


- South Sammamish Segment B Project Location
- Stream Crossing Field-Verified by Parametrix
- Stream Crossing Not Found Within Trail Corridor
- City of Sammamish Drainage Basin
- Catchment Area
- Contour - 20ft
- Drainage Structure
- Proposed Trail Stationing

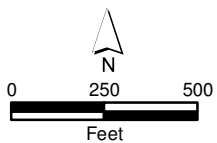
**Figure 2E**  
**Trail Drainage Structure**  
**Catchment Areas**



Path: P:\1554\_1521\_075\_SammamishTrail\Figures\_2A-2F\_StreamScreening\Fig\_2F\_Sammamish\_Trail\CatchmentAreas.mxd



**Parametrix**



- South Sammamish Segment B Project Location
- Stream Crossing Field-Verified by Parametrix
- Stream Crossing Not Found Within Trail Corridor
- City of Sammamish Drainage Basin
- Catchment Area
- Contour - 20ft
- Drainage Structure
- 480+00
- 485+00
- Proposed Trail Stationing

**Figure 2F**  
**Trail Drainage Structure**  
**Catchment Areas**



---

# MGS FLOOD PROJECT REPORT

Program Version: MGSFlood 4.38  
Program License Number: 200510005  
Project Simulation Performed on: 07/07/2016 4:17 PM  
Report Generation Date: 07/07/2016 4:17 PM

---

Input File Name: PineLake.fld  
Project Name: ELST - S Sammamish  
Analysis Title: Pine Lake Creek Flows  
Comments:

---

## PRECIPITATION INPUT

---

Computational Time Step (Minutes): 5

Extended Precipitation Time Series Selected  
Climatic Region Number: 13

Full Period of Record Available used for Routing  
Precipitation Station : 96004005 Puget East 40 in\_5min 10/01/1939-10/01/2097  
Evaporation Station : 961040 Puget East 40 in MAP  
Evaporation Scale Factor : 0.750

HSPF Parameter Region Number: 1  
HSPF Parameter Region Name : USGS Default

\*\*\*\*\* Default HSPF Parameters Used (Not Modified by User) \*\*\*\*\*

## \*\*\*\*\* WATERSHED DEFINITION \*\*\*\*\*

### Predevelopment/Post Development Tributary Area Summary

		Predeveloped	Post Developed
Total Subbasin Area (acres)	218.400	218.400	
Area of Links that Include Precip/Evap (acres)	0.000	0.000	
Total (acres)	218.400	218.400	

### -----SCENARIO: PREDEVELOPED

Number of Subbasins: 1

----- Subbasin : Offsite basin -----  
-----Area(Acres) -----  
Till Forest 0.900  
Till Pasture 10.100  
Till Grass 0.000  
Outwash Forest 194.600

Outwash Pasture	649.900
Outwash Grass	5.200
Wetland	64.200
Green Roof	0.000
User	0.000
Impervious	293.500
-----	
Subbasin Total	1218.400

-----**SCENARIO: POSTDEVELOPED**

Number of Subbasins: 1

----- Subbasin : Offsite basin -----

	-----Area(Acres) -----
Till Forest	0.900
Till Pasture	10.100
Till Grass	0.000
Outwash Forest	194.600
Outwash Pasture	649.900
Outwash Grass	5.200
Wetland	64.200
Green Roof	0.000
User	0.000
Impervious	293.500
-----	
Subbasin Total	1218.400

\*\*\*\*\* **LINK DATA** \*\*\*\*\*

-----**SCENARIO: PREDEVELOPED**

Number of Links: 0

\*\*\*\*\* **LINK DATA** \*\*\*\*\*

-----**SCENARIO: POSTDEVELOPED**

Number of Links: 0

\*\*\*\*\***FLOOD FREQUENCY AND DURATION STATISTICS**\*\*\*\*\*

-----**SCENARIO: PREDEVELOPED**

Number of Subbasins: 1  
Number of Links: 0

-----**SCENARIO: POSTDEVELOPED**

Number of Subbasins: 1  
Number of Links: 0

\*\*\*\*\***Groundwater Recharge Summary**\*\*\*\*\*

Recharge is computed as input to PerInd Groundwater Plus Infiltration in Structures

Total Predeveloped Recharge During Simulation	
Model Element	Recharge Amount (ac-ft)
Subbasin: Offsite basin	287701.800
<b>Total:</b>	<b>287701.800</b>

Total Post Developed Recharge During Simulation	
Model Element	Recharge Amount (ac-ft)
Subbasin: Offsite basin	287701.800
<b>Total:</b>	<b>287701.800</b>

**Total Predevelopment Recharge Equals Post Developed Average Recharge Per Year, (Number of Years= 158)**  
**Predeveloped: 1820.898 ac-ft/year, Post Developed: 1820.898 ac-ft/year**

\*\*\*\*\*Water Quality Facility Data \*\*\*\*\*

-----SCENARIO: PREDEVELOPED

Number of Links: 0

-----SCENARIO: POSTDEVELOPED

Number of Links: 0

\*\*\*\*\*Compliance Point Results \*\*\*\*\*

Scenario Predeveloped Compliance Subbasin: Offsite basin

Scenario Postdeveloped Compliance Subbasin: Offsite basin

**\*\*\* Point of Compliance Flow Frequency Data \*\*\***  
 Recurrence Interval Computed Using Gringorten Plotting Position

Predevelopment Runoff		Postdevelopment Runoff	
Tr (Years)	Discharge (cfs)	Tr (Years)	Discharge (cfs)
2-Year	138.779	2-Year	138.779
5-Year	182.787	5-Year	182.787
10-Year	223.774	10-Year	223.774
25-Year	283.550	25-Year	283.550
50-Year	346.764	50-Year	346.764
100-Year	431.045	100-Year	431.045
200-Year	471.265	200-Year	471.265

\*\* Record too Short to Compute Peak Discharge for These Recurrence Intervals

---

# MGS FLOOD PROJECT REPORT

**Program Version: MGSFlood 4.38**  
**Program License Number: 200510005**  
**Project Simulation Performed on: 07/07/2016 4:25 PM**  
**Report Generation Date: 07/07/2016 4:25 PM**

---

Input File Name: Stream 0155.fld  
Project Name: ELST - S Sammamish  
Analysis Title: Stream 0155 Drainage Basin  
Comments:

---

## PRECIPITATION INPUT

---

Computational Time Step (Minutes): 5

Extended Precipitation Time Series Selected  
Climatic Region Number: 14

Full Period of Record Available used for Routing  
Precipitation Station : 96004405 Puget East 44 in\_5min 10/01/1939-10/01/2097  
Evaporation Station : 961044 Puget East 44 in MAP  
Evaporation Scale Factor : 0.750

HSPF Parameter Region Number: 1  
HSPF Parameter Region Name : USGS Default

\*\*\*\*\* Default HSPF Parameters Used (Not Modified by User) \*\*\*\*\*

## \*\*\*\*\* WATERSHED DEFINITION \*\*\*\*\*

### Predevelopment/Post Development Tributary Area Summary

		Predeveloped	Post Developed
Total Subbasin Area (acres)	124.300	124.300	
Area of Links that Include Precip/Evap (acres)	0.000	0.000	
Total (acres)	124.300	124.300	

### -----SCENARIO: PREDEVELOPED

Number of Subbasins: 1

----- Subbasin : Offsite basin -----  
-----Area(Acres) -----  
Till Forest 5.000  
Till Pasture 7.000  
Till Grass 0.000  
Outwash Forest 41.400



Outwash Pasture	51.800
Outwash Grass	0.000
Wetland	7.900
Green Roof	0.000
User	0.000
Impervious	11.200
-----	
Subbasin Total	124.300

-----**SCENARIO: POSTDEVELOPED**

Number of Subbasins: 1

----- Subbasin : Offsite basin -----  
-----Area(Acres) -----

Till Forest	5.000
Till Pasture	7.000
Till Grass	0.000
Outwash Forest	41.400
Outwash Pasture	51.800
Outwash Grass	0.000
Wetland	7.900
Green Roof	0.000
User	0.000
Impervious	11.200
-----	
Subbasin Total	124.300

\*\*\*\*\* **LINK DATA** \*\*\*\*\*

-----**SCENARIO: PREDEVELOPED**

Number of Links: 0

\*\*\*\*\* **LINK DATA** \*\*\*\*\*

-----**SCENARIO: POSTDEVELOPED**

Number of Links: 0

\*\*\*\*\***FLOOD FREQUENCY AND DURATION STATISTICS**\*\*\*\*\*

-----**SCENARIO: PREDEVELOPED**

Number of Subbasins: 1  
Number of Links: 0

-----**SCENARIO: POSTDEVELOPED**

Number of Subbasins: 1  
Number of Links: 0

\*\*\*\*\***Groundwater Recharge Summary**\*\*\*\*\*

Recharge is computed as input to PerInd Groundwater Plus Infiltration in Structures

Total Predeveloped Recharge During Simulation	
Model Element	Recharge Amount (ac-ft)
Subbasin: Offsite basin	37065.800
<b>Total:</b>	<b>37065.800</b>

Total Post Developed Recharge During Simulation	
Model Element	Recharge Amount (ac-ft)
Subbasin: Offsite basin	37065.800
<b>Total:</b>	<b>37065.800</b>

**Total Predevelopment Recharge Equals Post Developed Average Recharge Per Year, (Number of Years= 158)**  
**Predeveloped: 234.594 ac-ft/year, Post Developed: 234.594 ac-ft/year**

\*\*\*\*\*Water Quality Facility Data \*\*\*\*\*

-----SCENARIO: PREDEVELOPED

Number of Links: 0

-----SCENARIO: POSTDEVELOPED

Number of Links: 0

\*\*\*\*\*Compliance Point Results \*\*\*\*\*

Scenario Predeveloped Compliance Subbasin: Offsite basin

Scenario Postdeveloped Compliance Subbasin: Offsite basin

**\*\*\* Point of Compliance Flow Frequency Data \*\*\***  
 Recurrence Interval Computed Using Gringorten Plotting Position

Predevelopment Runoff		Postdevelopment Runoff	
Tr (Years)	Discharge (cfs)	Tr (Years)	Discharge (cfs)
2-Year	6.145	2-Year	6.145
5-Year	8.096	5-Year	8.096
10-Year	10.355	10-Year	10.355
25-Year	14.877	25-Year	14.877
50-Year	17.343	50-Year	17.343
100-Year	20.275	100-Year	20.275
200-Year	22.453	200-Year	22.453

\*\* Record too Short to Compute Peak Discharge for These Recurrence Intervals

---

# MGS FLOOD PROJECT REPORT

**Program Version: MGSFlood 4.40**  
**Program License Number: 200510005**  
**Project Simulation Performed on: 09/02/2016 9:33 AM**  
**Report Generation Date: 09/02/2016 9:34 AM**

---

Input File Name: Ebright.fld  
Project Name: ELST - S Sammamish  
Analysis Title: STA 366+75 Basin  
Comments:

---

## PRECIPITATION INPUT

---

Computational Time Step (Minutes): 5

Extended Precipitation Time Series Selected  
Climatic Region Number: 0

Full Period of Record Available used for Routing  
Precipitation Station : 96004405 Puget East 44 in\_5min 10/01/1939-10/01/2097  
Evaporation Station : 961044 Puget East 44 in MAP  
Evaporation Scale Factor : 0.750

HSPF Parameter Region Number: 1  
HSPF Parameter Region Name : USGS Default

\*\*\*\*\* Default HSPF Parameters Used (Not Modified by User) \*\*\*\*\*

## \*\*\*\*\* WATERSHED DEFINITION \*\*\*\*\*

### Predevelopment/Post Development Tributary Area Summary

		Predeveloped	Post Developed
Total Subbasin Area (acres)	13.500	13.500	
Area of Links that Include Precip/Evap (acres)	0.000	0.000	
Total (acres)	13.500	13.500	

### -----SCENARIO: PREDEVELOPED

Number of Subbasins: 1

----- Subbasin : Offsite basin -----  
-----Area (Acres) -----  
Outwash Forest 3.000  
Outwash Pasture 7.600  
Impervious 2.900  
-----

Subbasin Total 13.500

-----SCENARIO: POSTDEVELOPED

Number of Subbasins: 1

----- Subbasin : Offsite basin -----	
	-----Area (Acres) -----
Outwash Forest	3.000
Outwash Pasture	7.600
Impervious	2.900
-----	
Subbasin Total	13.500

\*\*\*\*\* LINK DATA \*\*\*\*\*

-----SCENARIO: PREDEVELOPED

Number of Links: 0

\*\*\*\*\* LINK DATA \*\*\*\*\*

-----SCENARIO: POSTDEVELOPED

Number of Links: 0

\*\*\*\*\*FLOOD FREQUENCY AND DURATION STATISTICS\*\*\*\*\*

-----SCENARIO: PREDEVELOPED

Number of Subbasins: 1

Number of Links: 0

-----SCENARIO: POSTDEVELOPED

Number of Subbasins: 1

Number of Links: 0

\*\*\*\*\*Groundwater Recharge Summary \*\*\*\*\*

Recharge is computed as input to PerInd Groundwater Plus Infiltration in Structures

Total Predeveloped Recharge During Simulation	
Model Element	Recharge Amount (ac-ft)
-----	
Subbasin: Offsite basin	3873.594
-----	
Total:	3873.594

Total Post Developed Recharge During Simulation	
Model Element	Recharge Amount (ac-ft)
-----	
Subbasin: Offsite basin	3873.594
-----	
Total:	3873.594



**Total Predevelopment Recharge Equals Post Developed  
Average Recharge Per Year, (Number of Years= 158)  
Predeveloped: 24.516 ac-ft/year, Post Developed: 24.516 ac-ft/year**

**\*\*\*\*\*Water Quality Facility Data \*\*\*\*\***

**-----SCENARIO: PREDEVELOPED**

Number of Links: 0

**-----SCENARIO: POSTDEVELOPED**

Number of Links: 0

**\*\*\*\*\*Compliance Point Results \*\*\*\*\***

Scenario Predeveloped Compliance Subbasin: Offsite basin

Scenario Postdeveloped Compliance Subbasin: Offsite basin

**\*\*\* Point of Compliance Flow Frequency Data \*\*\***

Recurrence Interval Computed Using Gringorten Plotting Position

Predevelopment Runoff		Postdevelopment Runoff	
Tr (Years)	Discharge (cfs)	Tr (Years)	Discharge (cfs)
2-Year	1.451	2-Year	1.451
5-Year	1.877	5-Year	1.877
10-Year	2.308	10-Year	2.308
25-Year	2.819	25-Year	2.819
50-Year	3.480	50-Year	3.480
100-Year	4.303	100-Year	4.303
200-Year	4.929	200-Year	4.929

\*\* Record too Short to Compute Peak Discharge for These Recurrence Intervals

---

# MGS FLOOD PROJECT REPORT

**Program Version: MGSFlood 4.38**  
**Program License Number: 200510005**  
**Project Simulation Performed on: 07/07/2016 4:29 PM**  
**Report Generation Date: 07/07/2016 4:29 PM**

---

Input File Name: Zaccuse.fld  
Project Name: ELST - S Sammamish  
Analysis Title: Zaccuse Creek Flows  
Comments:

---

## PRECIPITATION INPUT

---

Computational Time Step (Minutes): 5

Extended Precipitation Time Series Selected  
Climatic Region Number: 14

Full Period of Record Available used for Routing  
Precipitation Station : 96004405 Puget East 44 in\_5min 10/01/1939-10/01/2097  
Evaporation Station : 961044 Puget East 44 in MAP  
Evaporation Scale Factor : 0.750

HSPF Parameter Region Number: 1  
HSPF Parameter Region Name : USGS Default

\*\*\*\*\* Default HSPF Parameters Used (Not Modified by User) \*\*\*\*\*

## \*\*\*\*\* WATERSHED DEFINITION \*\*\*\*\*

### Predevelopment/Post Development Tributary Area Summary

		Predeveloped	Post Developed
Total Subbasin Area (acres)	160.000	160.000	
Area of Links that Include Precip/Evap (acres)	0.000	0.000	
Total (acres)	160.000	160.000	

### -----SCENARIO: PREDEVELOPED

Number of Subbasins: 1

----- Subbasin : Offsite basin -----  
-----Area(Acres) -----  
Till Forest 0.000  
Till Pasture 0.000  
Till Grass 0.000  
Outwash Forest 26.500

Outwash Pasture	95.500
Outwash Grass	0.000
Wetland	1.200
Green Roof	0.000
User	0.000
Impervious	36.800
-----	
Subbasin Total	160.000

-----**SCENARIO: POSTDEVELOPED**

Number of Subbasins: 1

----- Subbasin : Offsite basin -----

	-----Area(Acres) -----
Till Forest	0.000
Till Pasture	0.000
Till Grass	0.000
Outwash Forest	26.500
Outwash Pasture	95.500
Outwash Grass	0.000
Wetland	1.200
Green Roof	0.000
User	0.000
Impervious	36.800
-----	
Subbasin Total	160.000

\*\*\*\*\* **LINK DATA** \*\*\*\*\*

-----**SCENARIO: PREDEVELOPED**

Number of Links: 0

\*\*\*\*\* **LINK DATA** \*\*\*\*\*

-----**SCENARIO: POSTDEVELOPED**

Number of Links: 0

\*\*\*\*\***FLOOD FREQUENCY AND DURATION STATISTICS**\*\*\*\*\*

-----**SCENARIO: PREDEVELOPED**

Number of Subbasins: 1  
Number of Links: 0

-----**SCENARIO: POSTDEVELOPED**

Number of Subbasins: 1  
Number of Links: 0

\*\*\*\*\***Groundwater Recharge Summary**\*\*\*\*\*

Recharge is computed as input to PerInd Groundwater Plus Infiltration in Structures

Total Predeveloped Recharge During Simulation	
Model Element	Recharge Amount (ac-ft)
Subbasin: Offsite basin	45460.010
<b>Total:</b>	<b>45460.010</b>

Total Post Developed Recharge During Simulation	
Model Element	Recharge Amount (ac-ft)
Subbasin: Offsite basin	45460.010
<b>Total:</b>	<b>45460.010</b>

**Total Predevelopment Recharge Equals Post Developed Average Recharge Per Year, (Number of Years= 158)**  
**Predeveloped: 287.722 ac-ft/year, Post Developed: 287.722 ac-ft/year**

\*\*\*\*\*Water Quality Facility Data \*\*\*\*\*

-----SCENARIO: PREDEVELOPED

Number of Links: 0

-----SCENARIO: POSTDEVELOPED

Number of Links: 0

\*\*\*\*\*Compliance Point Results \*\*\*\*\*

Scenario Predeveloped Compliance Subbasin: Offsite basin

Scenario Postdeveloped Compliance Subbasin: Offsite basin

**\*\*\* Point of Compliance Flow Frequency Data \*\*\***  
 Recurrence Interval Computed Using Gringorten Plotting Position

Predevelopment Runoff		Postdevelopment Runoff	
Tr (Years)	Discharge (cfs)	Tr (Years)	Discharge (cfs)
2-Year	18.400	2-Year	18.400
5-Year	23.806	5-Year	23.806
10-Year	29.303	10-Year	29.303
25-Year	35.806	25-Year	35.806
50-Year	44.161	50-Year	44.161
100-Year	54.588	100-Year	54.588
200-Year	62.548	200-Year	62.548

\*\* Record too Short to Compute Peak Discharge for These Recurrence Intervals



---

# MGS FLOOD PROJECT REPORT

**Program Version: MGSFlood 4.38**  
**Program License Number: 200510005**  
**Project Simulation Performed on: 07/07/2016 4:33 PM**  
**Report Generation Date: 07/07/2016 4:33 PM**

---

Input File Name: Inglewood.fld  
Project Name: ELST - S Sammamish  
Analysis Title: Inglewood Basin Creek Flows  
Comments:

---

## PRECIPITATION INPUT

---

Computational Time Step (Minutes): 5

Extended Precipitation Time Series Selected  
Climatic Region Number: 14

Full Period of Record Available used for Routing  
Precipitation Station : 96004405 Puget East 44 in\_5min 10/01/1939-10/01/2097  
Evaporation Station : 961044 Puget East 44 in MAP  
Evaporation Scale Factor : 0.750

HSPF Parameter Region Number: 1  
HSPF Parameter Region Name : USGS Default

\*\*\*\*\* Default HSPF Parameters Used (Not Modified by User) \*\*\*\*\*

## \*\*\*\*\* WATERSHED DEFINITION \*\*\*\*\*

### Predevelopment/Post Development Tributary Area Summary

		Predeveloped	Post Developed
Total Subbasin Area (acres)	733.200	733.200	
Area of Links that Include Precip/Evap (acres)	0.000	0.000	
Total (acres)	733.200	733.200	

### -----SCENARIO: PREDEVELOPED

Number of Subbasins: 1

----- Subbasin : Offsite basin -----  
-----Area(Acres) -----  
Till Forest 0.000  
Till Pasture 0.000  
Till Grass 0.000  
Outwash Forest 235.500

Outwash Pasture	852.300
Outwash Grass	83.500
Wetland	61.600
Green Roof	0.000
User	0.000
Impervious	500.300
-----	
Subbasin Total	1733.200

-----**SCENARIO: POSTDEVELOPED**

Number of Subbasins: 1

----- Subbasin : Offsite basin -----  
-----Area(Acres) -----

Till Forest	0.000
Till Pasture	0.000
Till Grass	0.000
Outwash Forest	235.500
Outwash Pasture	852.300
Outwash Grass	83.500
Wetland	61.600
Green Roof	0.000
User	0.000
Impervious	500.300
-----	
Subbasin Total	1733.200

\*\*\*\*\* **LINK DATA** \*\*\*\*\*

-----**SCENARIO: PREDEVELOPED**

Number of Links: 0

\*\*\*\*\* **LINK DATA** \*\*\*\*\*

-----**SCENARIO: POSTDEVELOPED**

Number of Links: 0

\*\*\*\*\***FLOOD FREQUENCY AND DURATION STATISTICS**\*\*\*\*\*

-----**SCENARIO: PREDEVELOPED**

Number of Subbasins: 1  
Number of Links: 0

-----**SCENARIO: POSTDEVELOPED**

Number of Subbasins: 1  
Number of Links: 0

\*\*\*\*\***Groundwater Recharge Summary**\*\*\*\*\*

Recharge is computed as input to PerInd Groundwater Plus Infiltration in Structures

Total Predeveloped Recharge During Simulation	
Model Element	Recharge Amount (ac-ft)
Subbasin: Offsite basin	449146.000
<b>Total:</b>	<b>449146.000</b>

Total Post Developed Recharge During Simulation	
Model Element	Recharge Amount (ac-ft)
Subbasin: Offsite basin	449146.000
<b>Total:</b>	<b>449146.000</b>

**Total Predevelopment Recharge Equals Post Developed Average Recharge Per Year, (Number of Years= 158)**  
**Predeveloped: 2842.696 ac-ft/year, Post Developed: 2842.696 ac-ft/year**

\*\*\*\*\*Water Quality Facility Data \*\*\*\*\*

-----SCENARIO: PREDEVELOPED

Number of Links: 0

-----SCENARIO: POSTDEVELOPED

Number of Links: 0

\*\*\*\*\*Compliance Point Results \*\*\*\*\*

Scenario Predeveloped Compliance Subbasin: Offsite basin

Scenario Postdeveloped Compliance Subbasin: Offsite basin

**\*\*\* Point of Compliance Flow Frequency Data \*\*\***  
 Recurrence Interval Computed Using Gringorten Plotting Position

Predevelopment Runoff		Postdevelopment Runoff	
Tr (Years)	Discharge (cfs)	Tr (Years)	Discharge (cfs)
2-Year	250.021	2-Year	250.021
5-Year	322.611	5-Year	322.611
10-Year	399.668	10-Year	399.668
25-Year	484.925	25-Year	484.925
50-Year	600.033	50-Year	600.033
100-Year	741.978	100-Year	741.978
200-Year	850.244	200-Year	850.244

\*\* Record too Short to Compute Peak Discharge for These Recurrence Intervals

---

# MGS FLOOD PROJECT REPORT

**Program Version: MGSFlood 4.38**  
**Program License Number: 200510005**  
**Project Simulation Performed on: 07/07/2016 4:34 PM**  
**Report Generation Date: 07/07/2016 4:34 PM**

---

Input File Name: Stream 0143L.fld  
Project Name: ELST - S Sammamish  
Analysis Title: Stream 0143L Drainage Basin  
Comments:

---

## PRECIPITATION INPUT

---

Computational Time Step (Minutes): 5

Extended Precipitation Time Series Selected  
Climatic Region Number: 14

Full Period of Record Available used for Routing  
Precipitation Station : 96004405 Puget East 44 in\_5min 10/01/1939-10/01/2097  
Evaporation Station : 961044 Puget East 44 in MAP  
Evaporation Scale Factor : 0.750

HSPF Parameter Region Number: 1  
HSPF Parameter Region Name : USGS Default

\*\*\*\*\* Default HSPF Parameters Used (Not Modified by User) \*\*\*\*\*

## \*\*\*\*\* WATERSHED DEFINITION \*\*\*\*\*

### Predevelopment/Post Development Tributary Area Summary

		Predeveloped	Post Developed
Total Subbasin Area (acres)	100.400	100.400	
Area of Links that Include Precip/Evap (acres)	0.000	0.000	
Total (acres)	100.400	100.400	

### -----SCENARIO: PREDEVELOPED

Number of Subbasins: 1

----- Subbasin : Offsite basin -----  
-----Area(Acres) -----  
Till Forest 2.300  
Till Pasture 3.100  
Till Grass 0.300  
Outwash Forest 19.000



Outwash Pasture	46.000
Outwash Grass	0.500
Wetland	0.000
Green Roof	0.000
User	0.000
Impervious	29.200
-----	
Subbasin Total	100.400

-----**SCENARIO: POSTDEVELOPED**

Number of Subbasins: 1

----- Subbasin : Offsite basin -----  
-----Area(Acres) -----

Till Forest	2.300
Till Pasture	3.100
Till Grass	0.300
Outwash Forest	19.000
Outwash Pasture	46.000
Outwash Grass	0.500
Wetland	0.000
Green Roof	0.000
User	0.000
Impervious	29.200
-----	
Subbasin Total	100.400

\*\*\*\*\* **LINK DATA** \*\*\*\*\*

-----**SCENARIO: PREDEVELOPED**

Number of Links: 0

\*\*\*\*\* **LINK DATA** \*\*\*\*\*

-----**SCENARIO: POSTDEVELOPED**

Number of Links: 0

\*\*\*\*\***FLOOD FREQUENCY AND DURATION STATISTICS**\*\*\*\*\*

-----**SCENARIO: PREDEVELOPED**

Number of Subbasins: 1  
Number of Links: 0

-----**SCENARIO: POSTDEVELOPED**

Number of Subbasins: 1  
Number of Links: 0

\*\*\*\*\***Groundwater Recharge Summary**\*\*\*\*\*

Recharge is computed as input to PerInd Groundwater Plus Infiltration in Structures

Total Predeveloped Recharge During Simulation	
Model Element	Recharge Amount (ac-ft)
Subbasin: Offsite basin	24956.560
<b>Total:</b>	<b>24956.560</b>

Total Post Developed Recharge During Simulation	
Model Element	Recharge Amount (ac-ft)
Subbasin: Offsite basin	24956.560
<b>Total:</b>	<b>24956.560</b>

**Total Predevelopment Recharge Equals Post Developed Average Recharge Per Year, (Number of Years= 158)**  
**Predeveloped: 157.953 ac-ft/year, Post Developed: 157.953 ac-ft/year**

\*\*\*\*\*Water Quality Facility Data \*\*\*\*\*

-----SCENARIO: PREDEVELOPED

Number of Links: 0

-----SCENARIO: POSTDEVELOPED

Number of Links: 0

\*\*\*\*\*Compliance Point Results \*\*\*\*\*

Scenario Predeveloped Compliance Subbasin: Offsite basin

Scenario Postdeveloped Compliance Subbasin: Offsite basin

**\*\*\* Point of Compliance Flow Frequency Data \*\*\***  
 Recurrence Interval Computed Using Gringorten Plotting Position

Predevelopment Runoff		Postdevelopment Runoff	
Tr (Years)	Discharge (cfs)	Tr (Years)	Discharge (cfs)
2-Year	14.675	2-Year	14.675
5-Year	18.962	5-Year	18.962
10-Year	23.797	10-Year	23.797
25-Year	28.688	25-Year	28.688
50-Year	36.506	50-Year	36.506
100-Year	45.145	100-Year	45.145
200-Year	51.393	200-Year	51.393

\*\* Record too Short to Compute Peak Discharge for These Recurrence Intervals

# HY-8 Culvert Analysis Report

## Project Notes

Project Title: East Lake Sammamish Master Plan Trail - South Sammamish Segment B

Designer: Craig Buitrago

Project Date: Monday, August 01, 2016

Notes:

**Project Units: U.S. Customary Units**

**Outlet Control Option: Profiles**

**Exit Loss Option: Standard Method**

**Crossing Notes: Pine Lk Creek Cul.1**

## Crossing Discharge Data

Discharge Selection Method: Specify Minimum, Design, and Maximum Flow

Minimum Flow: 0.87 cfs

Design Flow: 283.55 cfs

Maximum Flow: 431 cfs

Design Flow: 25-year discharge from MGSFlood

Maximum Flow: 100-year discharge from MGSFlood

Minimum Flow: Defined as low flow design discharge for ungaged streams according to King County 2016 Surface Water Design Manual

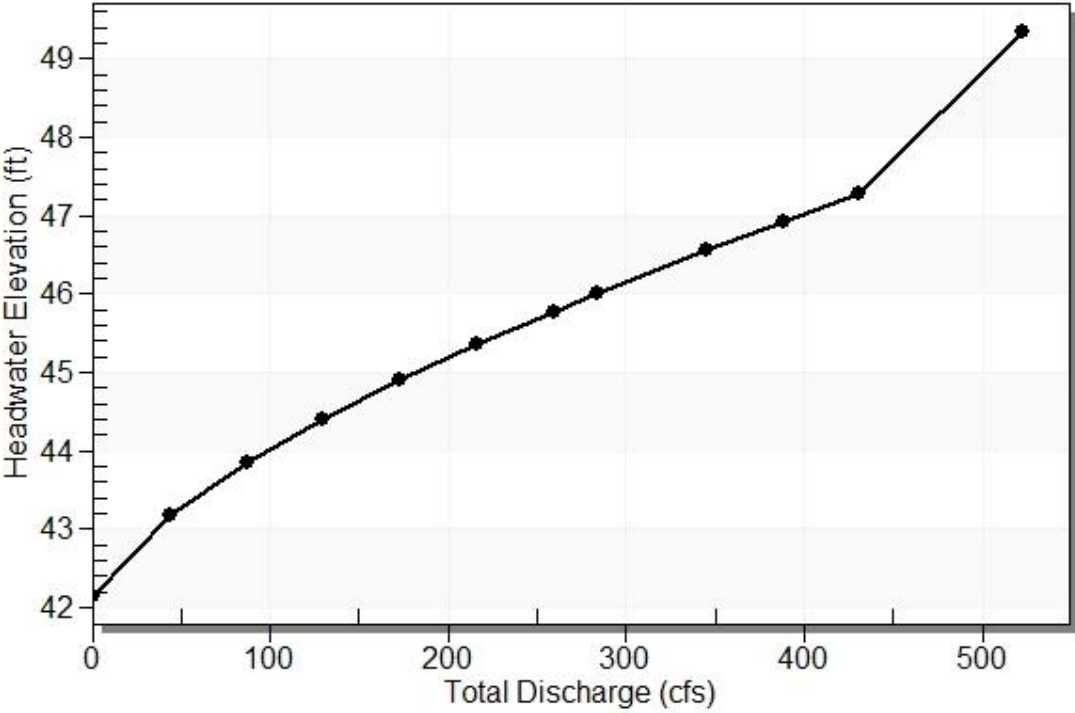
**Table 1 - Summary of Culvert Flows at Crossing: Pine Lk Creek Cul.1**

Headwater Elevation (ft)	Total Discharge (cfs)	Culvert 1 Discharge (cfs)	Roadway Discharge (cfs)	Iterations
42.16	0.87	0.87	0.00	1
43.17	43.88	43.88	0.00	1
43.85	86.90	86.90	0.00	1
44.41	129.91	129.91	0.00	1
44.90	172.92	172.92	0.00	1
45.36	215.94	215.94	0.00	1
45.78	258.95	258.95	0.00	1
46.01	283.55	283.55	0.00	1
46.55	344.97	344.97	0.00	1
46.92	387.99	387.99	0.00	1
47.27	431.00	431.00	0.00	1
48.00	522.39	522.39	0.00	Overtopping



**Rating Curve Plot for Crossing: Pine Lk Creek Cul.1**

**Total Rating Curve**  
Crossing: Pine Lk Creek Cul.1



**Culvert Notes: Culvert 1**

**Table 2 - Culvert Summary Table: Culvert 1**

Total Discharge (cfs)	Culvert Discharge (cfs)	Headwater Elevation (ft)	Inlet Control Depth (ft)	Outlet Control Depth (ft)	Flow Type	Normal Depth (ft)	Critical Depth (ft)	Outlet Depth (ft)	Tailwater Depth (ft)	Outlet Velocity (ft/s)	Tailwater Velocity (ft/s)
0.87	0.87	42.16	0.030	0.187	3-M1t	0.023	0.019	0.037	0.127	1.699	1.099
43.88	43.88	43.17	1.025	1.196	3-M1t	0.792	0.665	1.141	1.231	2.748	4.214
86.90	86.90	43.85	1.616	1.881	3-M1t	1.211	1.067	1.684	1.774	3.686	5.130
129.91	129.91	44.41	2.112	2.442	3-M1t	1.550	1.397	2.095	2.185	4.430	5.735
172.92	172.92	44.90	2.554	2.935	3-M1t	1.851	1.685	2.435	2.525	5.072	6.197
215.94	215.94	45.36	2.962	3.385	3-M1t	2.110	1.953	2.731	2.821	5.648	6.576
258.95	258.95	45.78	3.370	3.805	3-M1t	2.357	2.206	2.994	3.084	6.178	6.900
283.55	283.55	46.01	3.603	4.035	3-M1t	2.487	2.345	3.134	3.224	6.463	7.067
344.97	344.97	46.55	4.101	4.583	3-M1t	2.802	2.656	3.453	3.543	7.135	7.439
387.99	387.99	46.92	4.449	4.949	3-M1t	3.005	2.871	3.658	3.748	7.576	7.671
431.00	431.00	47.27	4.807	5.305	7-M1t	3.205	3.081	3.850	3.940	7.997	7.882

\*\*\*\*\*

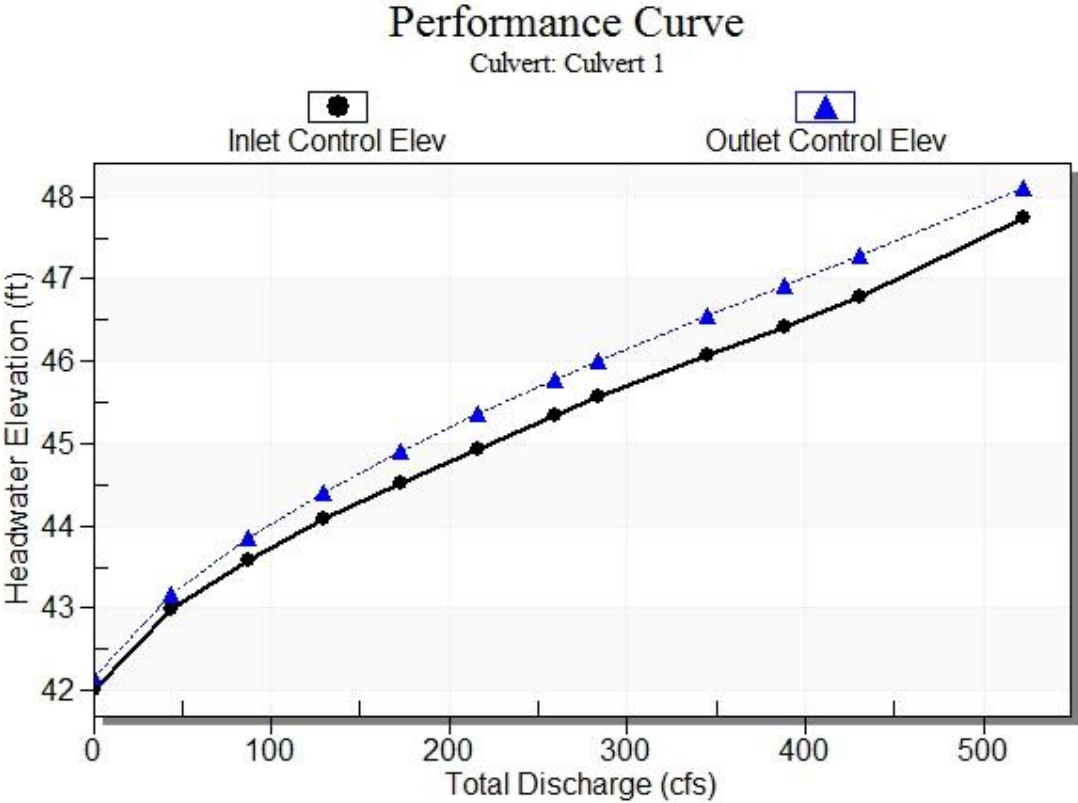
Straight Culvert

Inlet Elevation (invert): 41.97 ft, Outlet Elevation (invert): 41.69 ft

Culvert Length: 19.00 ft, Culvert Slope: 0.0147

\*\*\*\*\*

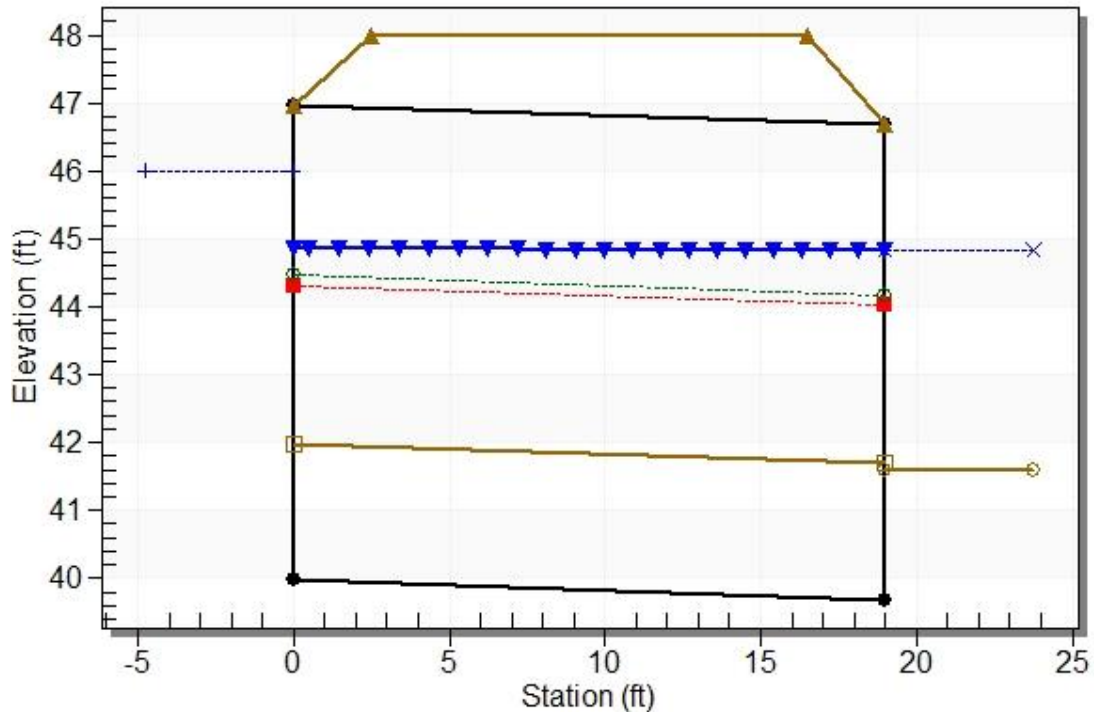
Culvert Performance Curve Plot: Culvert 1



## Water Surface Profile Plot for Culvert: Culvert 1

Crossing - Pine Lk Creek Cul.1, Design Discharge - 283.6 cfs

Culvert - Culvert 1, Culvert Discharge - 283.6 cfs



### Site Data - Culvert 1

Site Data Option: Culvert Invert Data

Inlet Station: 0.00 ft

Inlet Elevation: 39.97 ft

Outlet Station: 19.00 ft

Outlet Elevation: 39.69 ft

Number of Barrels: 1

### Culvert Data Summary - Culvert 1

Barrel Shape: Concrete Box

Barrel Span: 14.00 ft

Barrel Rise: 7.00 ft

Barrel Material: Concrete

Embedment: 24.00 in

Barrel Manning's n: 0.0120 (top and sides)

Manning's n: 0.0400 (bottom)

Culvert Type: Straight

Inlet Configuration: 1:1 Bevel Headwall



Inlet Depression: NONE

Flow (cfs)	Water Surface Elev (ft)	Depth (ft)	Velocity (ft/s)	Shear (psf)	Froude Number
0.87	41.73	0.13	1.10	0.12	0.56
43.88	42.83	1.23	4.21	1.13	0.76
86.90	43.37	1.77	5.13	1.63	0.79
129.91	43.78	2.18	5.73	2.00	0.82
172.92	44.13	2.53	6.20	2.32	0.83
215.94	44.42	2.82	6.58	2.59	0.84
258.95	44.68	3.08	6.90	2.83	0.85
283.55	44.82	3.22	7.07	2.96	0.85
344.97	45.14	3.54	7.44	3.25	0.86
387.99	45.35	3.75	7.67	3.44	0.87
431.00	45.54	3.94	7.88	3.61	0.88

**Table 3 - Downstream Channel Rating Curve (Crossing: Pine Lk Creek Cul.1)**

**Tailwater Channel Data - Pine Lk Creek Cul.1**

Tailwater Channel Option: Trapezoidal Channel

Bottom Width: 6.00 ft

Side Slope (H:V): 2.00 (\_:1)

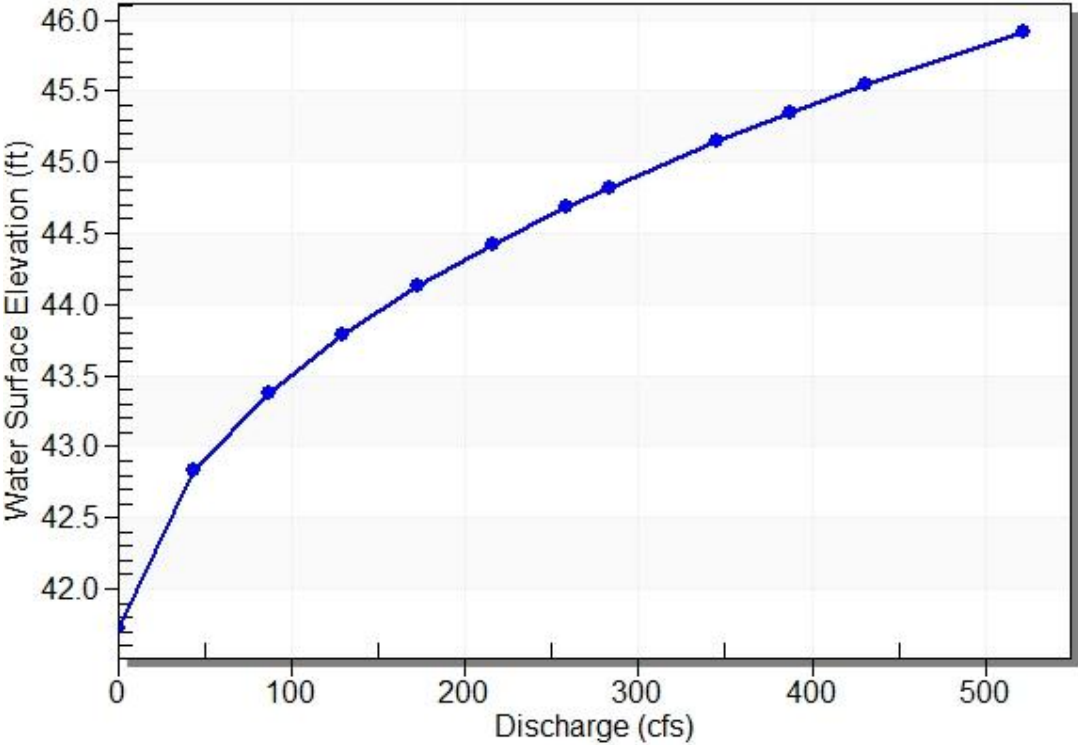
Channel Slope: 0.0147

Channel Manning's n: 0.0400

Channel Invert Elevation: 41.60 ft

**Tailwater Rating Curve Plot for Crossing: Pine Lk Creek Cul.1**

**Downstream Channel Rating Curve**



**Roadway Data for Crossing: Pine Lk Creek Cul.1**

- Roadway Profile Shape: Constant Roadway Elevation
- Crest Length: 100.00 ft
- Crest Elevation: 48.00 ft
- Roadway Surface: Paved
- Roadway Top Width: 14.00 ft

# HY-8 Culvert Analysis Report

## Project Notes

Project Title: East Lake Sammamish Master Plan Trail - South Sammamish Segment B

Designer: Craig Buitrago

Project Date: Monday, August 01, 2016

Notes:

**Project Units: U.S. Customary Units**

**Outlet Control Option: Profiles**

**Exit Loss Option: Standard Method**

**Crossing Notes: Pine Lk Creek Cul.2**

## Crossing Discharge Data

Discharge Selection Method: Specify Minimum, Design, and Maximum Flow

Minimum Flow: 0.87 cfs

Design Flow: 283.55 cfs

Maximum Flow: 431.05 cfs

Design Flow: 25-year discharge from MGSFlood

Maximum Flow: 100-year discharge from MGSFlood

Minimum Flow: Defined as low flow design discharge for ungaged streams according to King County 2016 Surface Water Design Manual

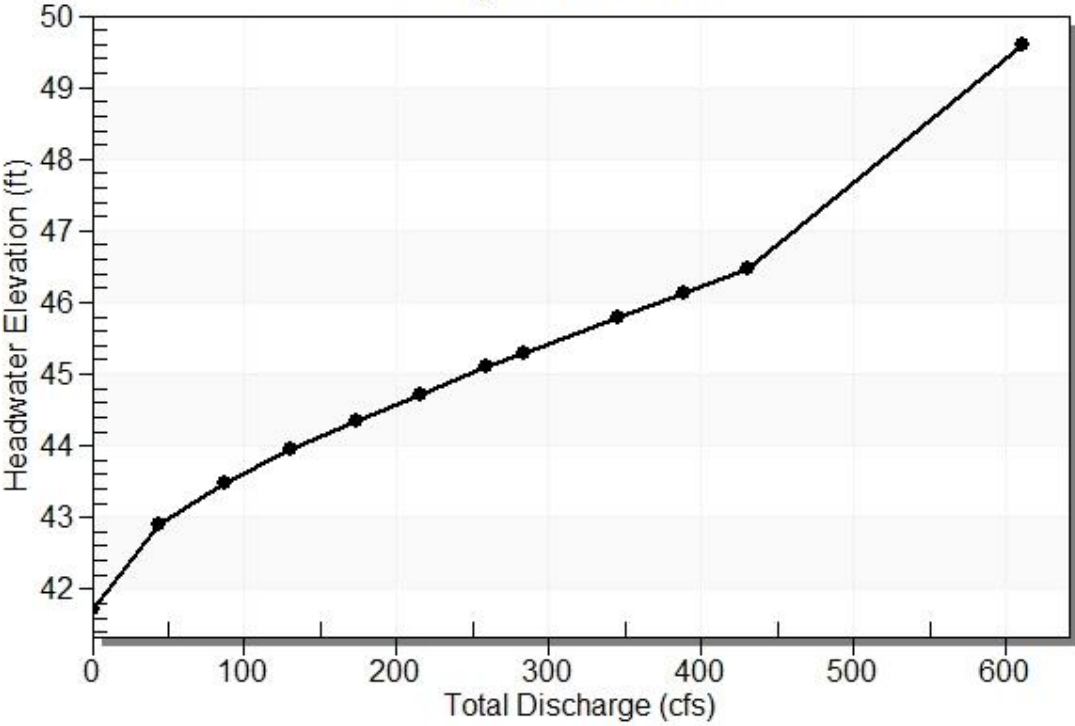
**Table 1 - Summary of Culvert Flows at Crossing: Pine Lk Creek Cul.2**

Headwater Elevation (ft)	Total Discharge (cfs)	Culvert 2 Discharge (cfs)	Roadway Discharge (cfs)	Iterations
41.73	0.87	0.87	0.00	1
42.90	43.89	43.89	0.00	1
43.49	86.91	86.91	0.00	1
43.95	129.92	129.92	0.00	1
44.34	172.94	172.94	0.00	1
44.70	215.96	215.96	0.00	1
45.09	258.98	258.98	0.00	1
45.29	283.55	283.55	0.00	1
45.79	345.01	345.01	0.00	1
46.14	388.03	388.03	0.00	1
46.48	431.05	431.05	0.00	1
48.00	610.58	610.58	0.00	Overtopping



**Rating Curve Plot for Crossing: Pine Lk Creek Cul.2**

**Total Rating Curve**  
Crossing: Pine Lk Creek Cul.2



**Culvert Notes: Culvert 2**

**Table 2 - Culvert Summary Table: Culvert 2**

Total Discharge (cfs)	Culvert Discharge (cfs)	Headwater Elevation (ft)	Inlet Control Depth (ft)	Outlet Control Depth (ft)	Flow Type	Normal Depth (ft)	Critical Depth (ft)	Outlet Depth (ft)	Tailwater Depth (ft)	Outlet Velocity (ft/s)	Tailwater Velocity (ft/s)
0.87	0.87	41.73	0.028	3.143	1-S1t	0.016	0.018	3.643	0.133	0.017	1.046
43.89	43.89	42.90	1.013	4.308	1-S1t	0.657	0.666	4.796	1.286	0.654	3.981
86.91	86.91	43.49	1.597	4.897	1-S1t	1.014	1.052	5.361	1.851	1.158	4.839
129.92	129.92	43.95	2.087	5.355	1-S1t	1.293	1.394	5.787	2.277	1.701	5.406
172.94	172.94	44.34	2.526	5.750	1-S1f	1.550	1.685	6.000	2.630	2.265	5.840
215.96	215.96	44.70	2.929	6.112	1-S1f	1.774	1.954	6.000	2.936	2.828	6.196
258.98	258.98	45.09	3.304	6.504	4-FFf	1.980	2.205	6.000	3.209	3.391	6.500
283.55	283.55	45.29	3.517	6.704	4-FFf	2.098	2.342	6.000	3.353	3.713	6.657
345.01	345.01	45.79	4.049	7.200	4-FFf	2.359	2.670	6.000	3.684	4.518	7.007
388.03	388.03	46.14	4.404	7.546	4-FFf	2.532	2.886	6.000	3.895	5.081	7.224
431.05	431.05	46.48	4.721	7.894	4-FFf	2.705	3.082	6.000	4.093	5.645	7.423

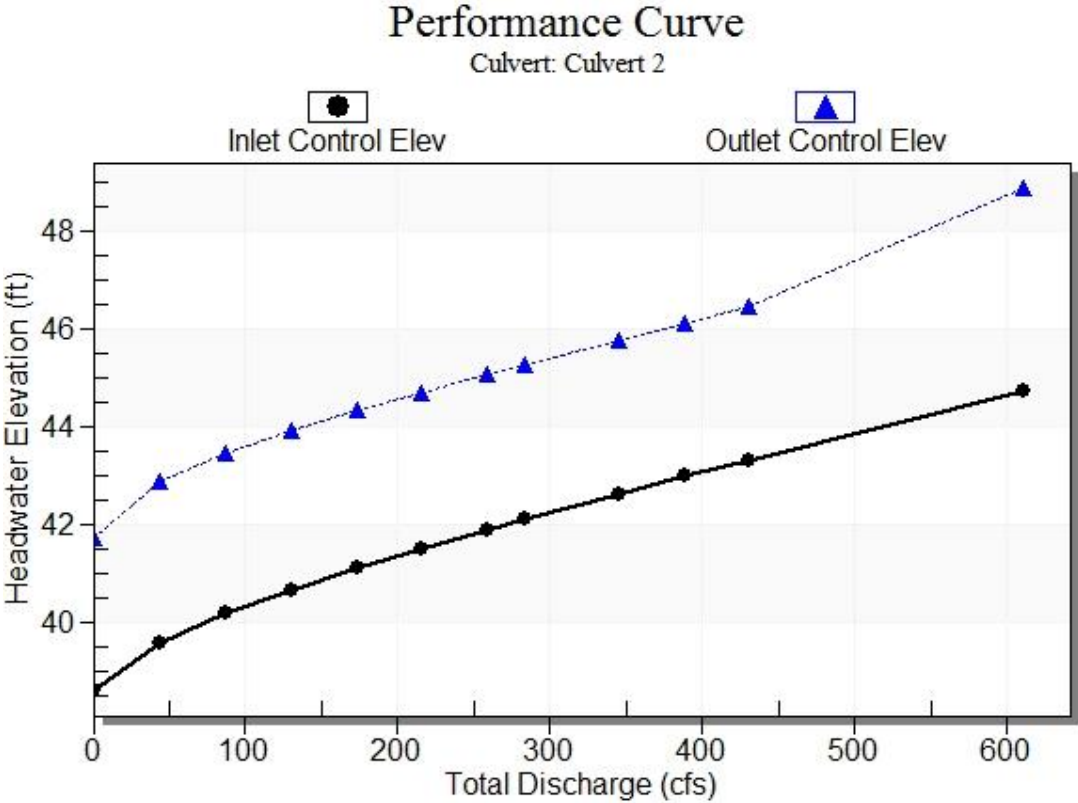
\*\*\*\*\*

Straight Culvert

Inlet Elevation (invert): 38.59 ft, Outlet Elevation (invert): 38.09 ft  
 Culvert Length: 19.01 ft, Culvert Slope: 0.0263

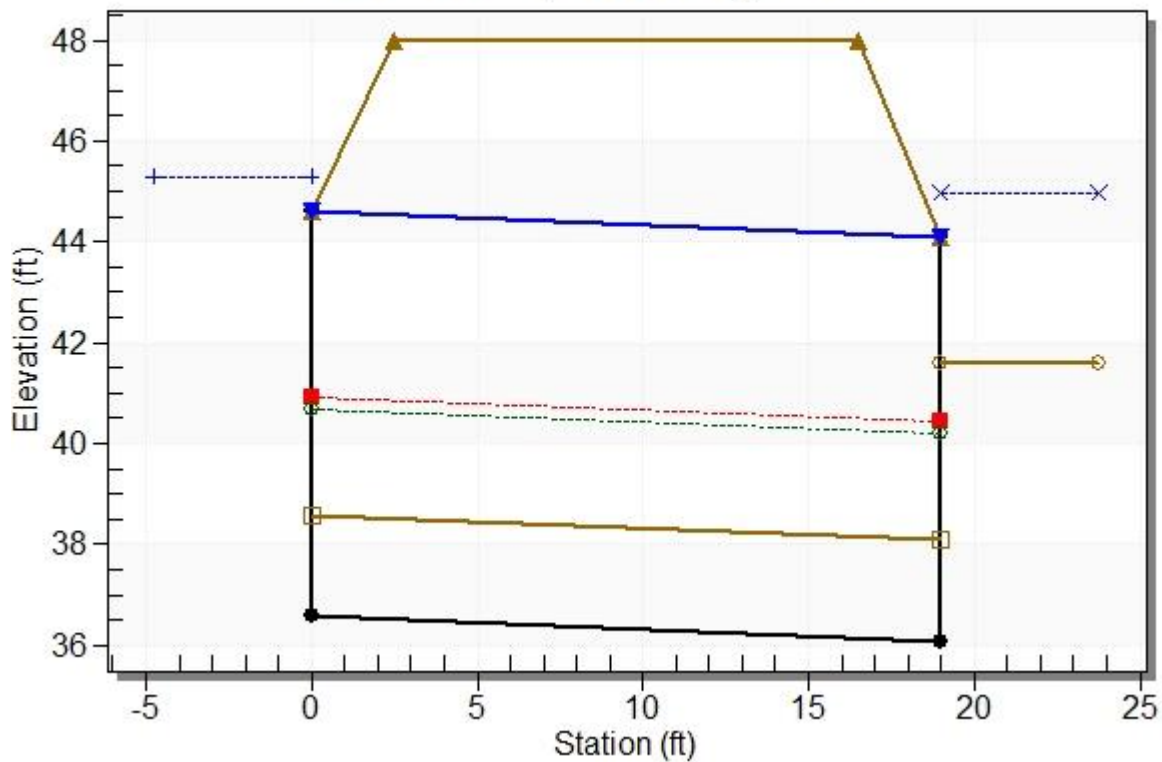
\*\*\*\*\*

Culvert Performance Curve Plot: Culvert 2



## Water Surface Profile Plot for Culvert: Culvert 2

Crossing - Pine Lk Creek Cul.2, Design Discharge - 283.6 cfs  
Culvert - Culvert 2, Culvert Discharge - 283.6 cfs



### Site Data - Culvert 2

Site Data Option: Culvert Invert Data

Inlet Station: 0.00 ft

Inlet Elevation: 36.59 ft

Outlet Station: 19.00 ft

Outlet Elevation: 36.09 ft

Number of Barrels: 1

### Culvert Data Summary - Culvert 2

Barrel Shape: Concrete Box

Barrel Span: 14.00 ft

Barrel Rise: 8.00 ft

Barrel Material: Concrete

Embedment: 24.00 in

Barrel Manning's n: 0.0120 (top and sides)

Manning's n: 0.0400 (bottom)



Culvert Type: Straight

Inlet Configuration: 1:1 Bevel Headwall

Flow (cfs)	Water Surface Elev (ft)	Depth (ft)	Velocity (ft/s)	Shear (psf)	Froude Number
0.87	41.73	0.13	1.05	0.10	0.52
43.89	42.89	1.29	3.98	1.00	0.71
86.91	43.45	1.85	4.84	1.44	0.74
129.92	43.88	2.28	5.41	1.78	0.76
172.94	44.23	2.63	5.84	2.05	0.77
215.96	44.54	2.94	6.20	2.29	0.78
258.98	44.81	3.21	6.50	2.50	0.79
283.55	44.95	3.35	6.66	2.62	0.79
345.01	45.28	3.68	7.01	2.87	0.80
388.03	45.50	3.90	7.22	3.04	0.81
431.05	45.69	4.09	7.42	3.19	0.81

Inlet Depression: NONE

### Table 3 - Downstream Channel Rating Curve (Crossing: Pine Lk Creek Cul.2)

#### Tailwater Channel Data - Pine Lk Creek Cul.2

Tailwater Channel Option: Trapezoidal Channel

Bottom Width: 6.00 ft

Side Slope (H:V): 2.00 (\_:1)

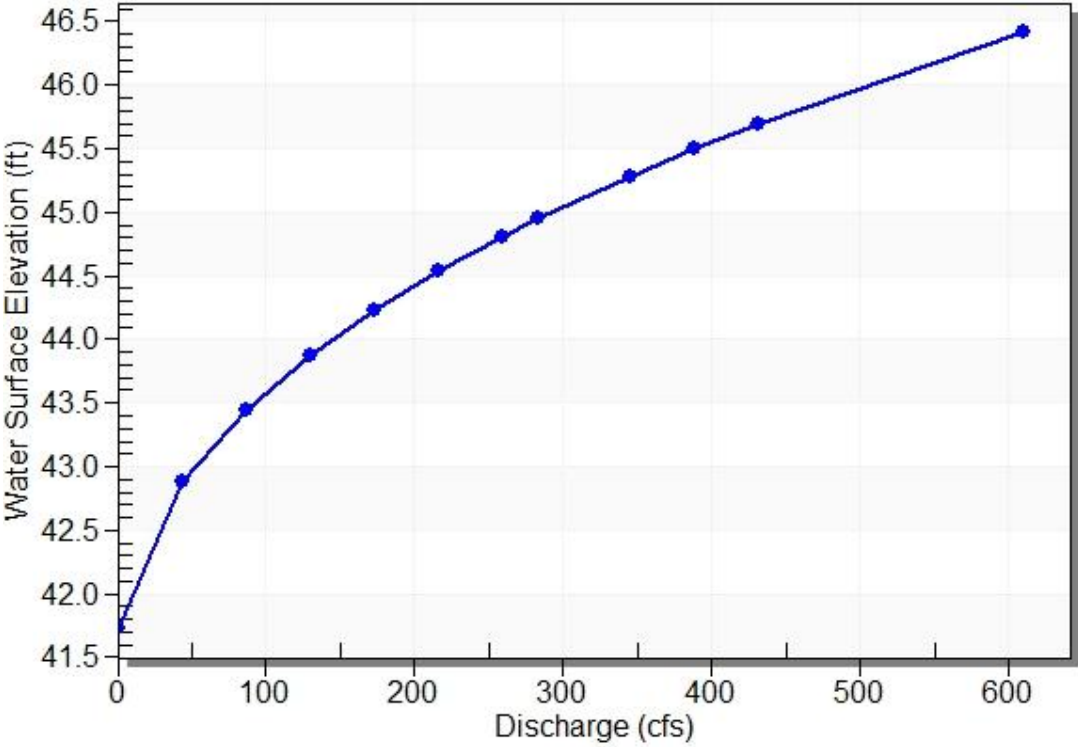
Channel Slope: 0.0125

Channel Manning's n: 0.0400

Channel Invert Elevation: 41.60 ft

**Tailwater Rating Curve Plot for Crossing: Pine Lk Creek Cul.2**

**Downstream Channel Rating Curve**



**Roadway Data for Crossing: Pine Lk Creek Cul.2**

- Roadway Profile Shape: Constant Roadway Elevation
- Crest Length: 100.00 ft
- Crest Elevation: 48.00 ft
- Roadway Surface: Paved
- Roadway Top Width: 14.00 ft

# HY-8 Culvert Analysis Report

## Project Notes

Project Title: East Lake Sammamish Master Plan Trail - South Sammamish Segment B

Designer: Craig Buitrago

Project Date: Monday, August 01, 2016

Notes:

**Project Units: U.S. Customary Units**

**Outlet Control Option: Profiles**

**Exit Loss Option: Standard Method**

**Crossing Notes: Stream 0155**

**Minimum Flow:** Defined as low flow design discharge for ungaged streams according to King County 2016 Surface Water Design Manual

**Crossing Discharge Data**

Discharge Selection Method: Specify Minimum, Design, and Maximum Flow

Minimum Flow: 0.09 cfs

Design Flow: 14.88 cfs

**Design Flow:** 25-year discharge from MGSFlood

Maximum Flow: 20.27 cfs

**Maximum Flow:** 100-year discharge from MGSFlood

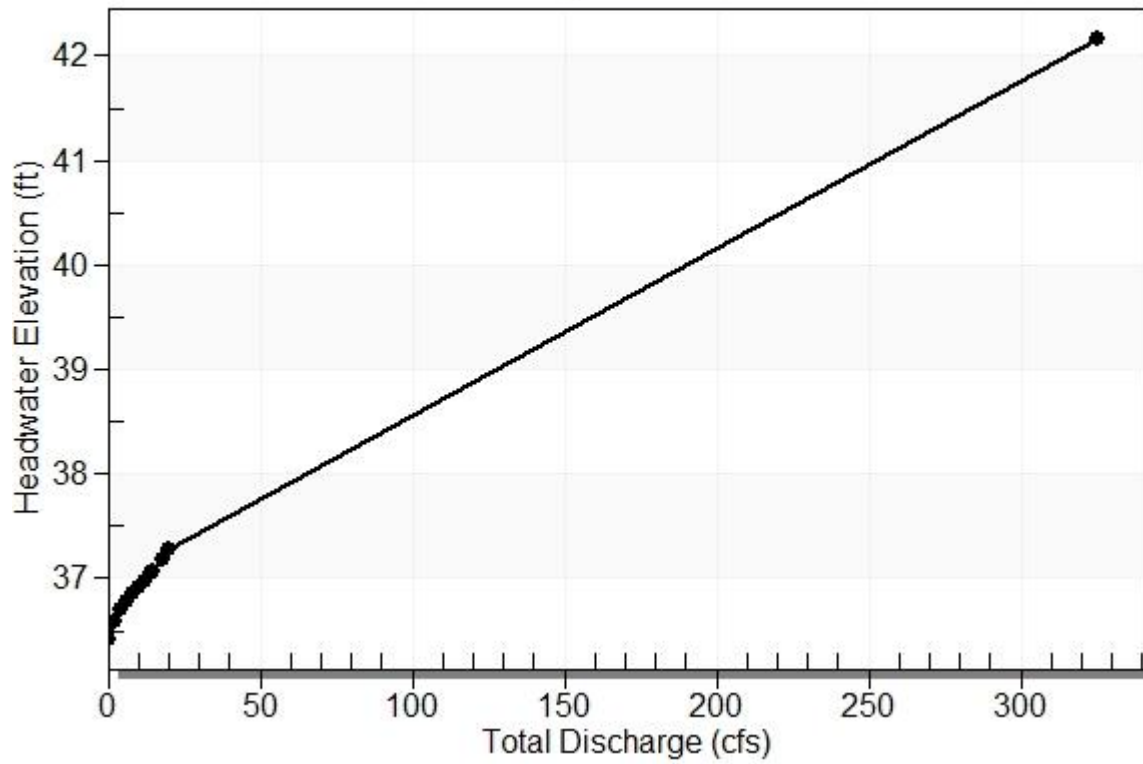
**Table 1 - Summary of Culvert Flows at Crossing: Stream 0155**

Headwater Elevation (ft)	Total Discharge (cfs)	Culvert 2 Discharge (cfs)	Roadway Discharge (cfs)	Iterations
36.43	0.09	0.09	0.00	1
36.60	2.11	2.11	0.00	1
36.70	4.13	4.13	0.00	1
36.78	6.14	6.14	0.00	1
36.85	8.16	8.16	0.00	1
36.92	10.18	10.18	0.00	1
36.98	12.20	12.20	0.00	1
37.04	14.22	14.22	0.00	1
37.06	14.88	14.88	0.00	1
37.18	18.25	18.25	0.00	1
37.27	20.27	20.27	0.00	1
42.00	325.18	325.18	0.00	Overtopping

**Rating Curve Plot for Crossing: Stream 0155**

**Total Rating Curve**

Crossing: 0155 Creek



**Culvert Notes: Culvert 2**



**Table 2 - Culvert Summary Table: Culvert 2**

Total Discharge (cfs)	Culvert Discharge (cfs)	Headwater Elevation (ft)	Inlet Control Depth (ft)	Outlet Control Depth (ft)	Flow Type	Normal Depth (ft)	Critical Depth (ft)	Outlet Depth (ft)	Tailwater Depth (ft)	Outlet Velocity (ft/s)	Tailwater Velocity (ft/s)
0.09	0.09	36.43	0.005	0.0*	1-S2n	0.002	0.003	-1.#IO	0.041	0.002	0.718
2.11	2.11	36.60	0.177	0.0*	1-S2n	0.037	0.121	0.107	0.263	1.366	2.272
4.13	4.13	36.70	0.278	0.0*	1-S2n	0.072	0.194	0.187	0.387	1.662	2.828
6.14	6.14	36.78	0.360	0.0*	1-S2n	0.107	0.256	0.205	0.484	2.304	3.202
8.16	8.16	36.85	0.432	0.0*	1-S2n	0.143	0.311	0.238	0.566	2.740	3.489
10.18	10.18	36.92	0.497	0.0*	1-S2n	0.178	0.362	0.178	0.639	4.274	3.726
12.20	12.20	36.98	0.559	0.0*	1-S2n	0.213	0.410	0.213	0.704	4.446	3.928
14.22	14.22	37.04	0.622	0.0*	1-S2n	0.248	0.455	0.341	0.765	3.788	4.105
14.88	14.88	37.06	0.643	0.0*	1-S2n	0.260	0.470	0.345	0.783	3.940	4.159
18.25	18.25	37.18	0.761	0.0*	1-S2n	0.319	0.535	0.319	0.873	5.055	4.406
20.27	20.27	37.27	0.854	0.0*	1-S2n	0.354	0.575	0.424	0.922	4.888	4.538

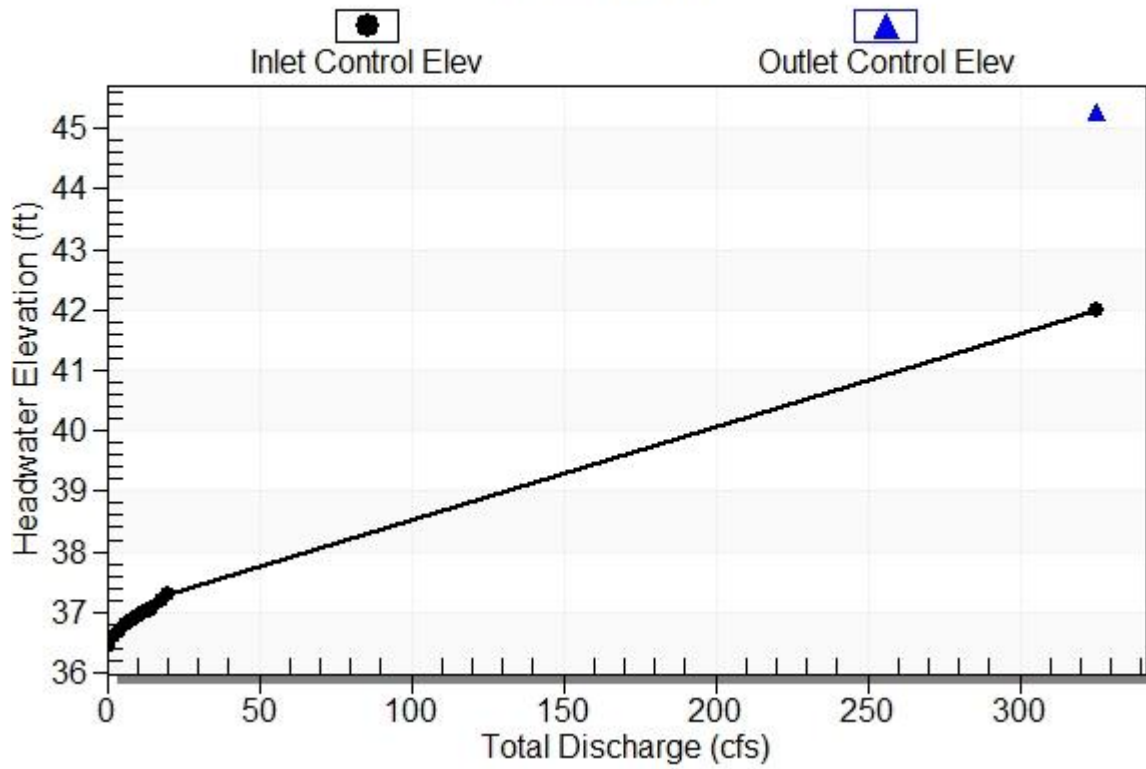
\* Full Flow Headwater elevation is below inlet invert.

\*\*\*\*\*  
Straight Culvert  
Inlet Elevation (invert): 36.42 ft, Outlet Elevation (invert): 35.31 ft  
Culvert Length: 13.05 ft, Culvert Slope: 0.0854  
\*\*\*\*\*

### Culvert Performance Curve Plot: Culvert 2

## Performance Curve

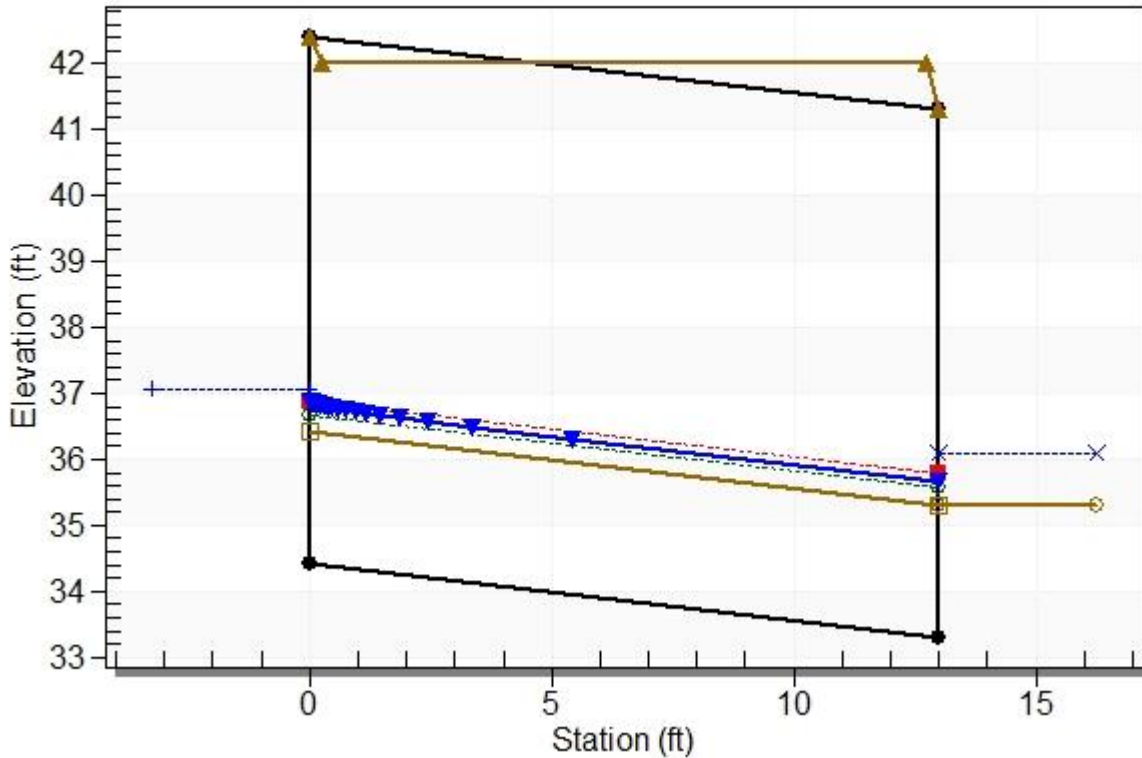
Culvert: Culvert 2



## Water Surface Profile Plot for Culvert: Culvert 2

Crossing - 0155 Creek, Design Discharge - 14.9 cfs

Culvert - Culvert 2, Culvert Discharge - 14.9 cfs



### Site Data - Culvert 2

Site Data Option: Culvert Invert Data

Inlet Station: 0.00 ft

Inlet Elevation: 34.42 ft

Outlet Station: 13.00 ft

Outlet Elevation: 33.31 ft

Number of Barrels: 1

### Culvert Data Summary - Culvert 2

Barrel Shape: Concrete Box

Barrel Span: 8.00 ft

Barrel Rise: 8.00 ft

Barrel Material: Concrete

Embedment: 24.00 in

Barrel Manning's n: 0.0120 (top and sides)

Manning's n: 0.0400 (bottom)



Culvert Type: Straight

Inlet Configuration: 1:1 Bevel Headwall

Flow (cfs)	Water Surface Elev (ft)	Depth (ft)	Velocity (ft/s)	Shear (psf)	Froude Number
0.09	35.35	0.04	0.72	0.07	0.64
2.11	35.57	0.26	2.27	0.46	0.84
4.13	35.70	0.39	2.83	0.67	0.88
6.14	35.79	0.48	3.20	0.84	0.90
8.16	35.88	0.57	3.49	0.98	0.92
10.18	35.95	0.64	3.73	1.11	0.94
12.20	36.01	0.70	3.93	1.22	0.95
14.22	36.07	0.76	4.11	1.33	0.96
14.88	36.09	0.78	4.16	1.36	0.96
18.25	36.18	0.87	4.41	1.51	0.97
20.27	36.23	0.92	4.54	1.60	0.98

Inlet Depression: NONE

### Table 3 - Downstream Channel Rating Curve (Crossing: Stream 0155)

#### Tailwater Channel Data - Stream 0155

Tailwater Channel Option: Trapezoidal Channel

Bottom Width: 3.00 ft

Side Slope (H:V): 2.00 (\_:1)

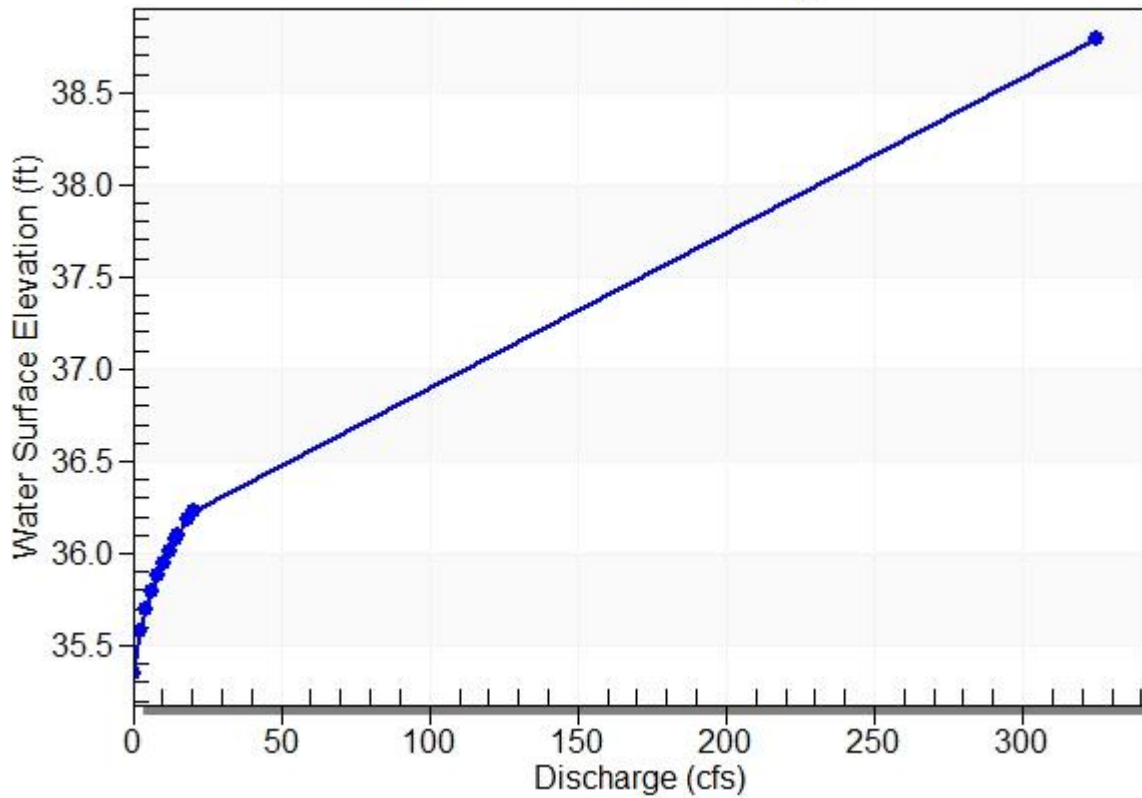
Channel Slope: 0.0278

Channel Manning's n: 0.0400

Channel Invert Elevation: 35.31 ft

### Tailwater Rating Curve Plot for Crossing: Stream 0155

#### Downstream Channel Rating Curve



### Roadway Data for Crossing: Stream 0155

Roadway Profile Shape: Constant Roadway Elevation

Crest Length: 100.00 ft

Crest Elevation: 42.00 ft

Roadway Surface: Paved

Roadway Top Width: 12.50 ft

# HY-8 Culvert Analysis Report

## Project Notes

Project Title: East Lake Sammamish Master Plan Trail - South Sammamish Segment B

Designer: Craig Buitrago

Project Date: Monday, August 01, 2016

Notes:

**Project Units: U.S. Customary Units**

**Outlet Control Option: Profiles**

**Exit Loss Option: Standard Method**

**Crossing Notes: Ebright Creek**

## Crossing Discharge Data

Discharge Selection Method: Specify Minimum, Design, and Maximum Flow

Minimum Flow: 0.51 cfs

Design Flow: 145.27 cfs

Maximum Flow: 206.83 cfs

Design Flow: 25-year discharge from MGSFlood

Maximum Flow: 100-year discharge from MGSFlood

Minimum Flow: Defined as low flow design discharge for ungaged streams according to King County 2016 Surface Water Design Manual

**Table 1 - Summary of Culvert Flows at Crossing: Ebright Creek**

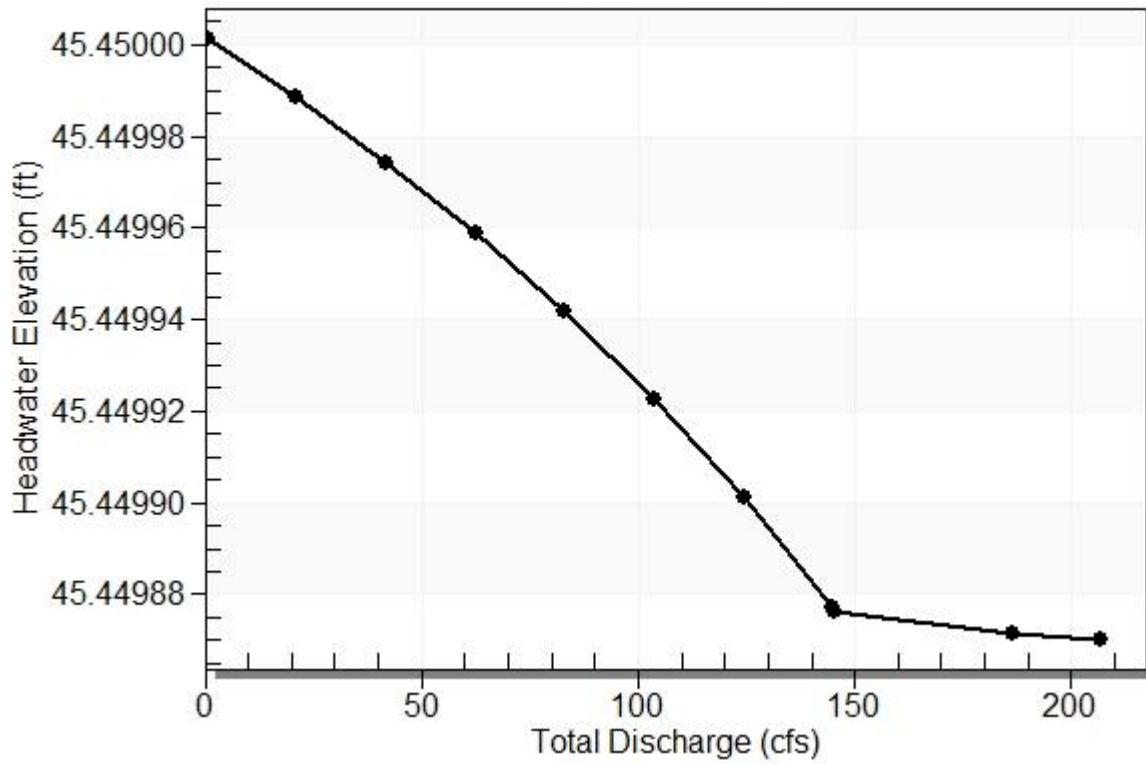
Headwater Elevation (ft)	Total Discharge (cfs)	Culvert 2 Discharge (cfs)	Roadway Discharge (cfs)	Iterations
45.45	0.51	0.51	0.00	1
45.45	21.14	450.23	1966.15	4
45.45	41.77	450.22	1966.14	4
45.45	62.41	450.16	1966.12	4
45.45	83.04	450.22	1966.11	4
45.45	103.67	450.22	1966.09	4
45.45	124.30	450.22	1966.07	4
45.45	144.93	450.22	1966.05	4
45.45	145.27	450.22	1966.05	3
45.45	186.20	450.21	1966.05	5
45.45	206.83	450.13	1966.04	5
42.00	0.61	0.61	0.00	Overtopping



### Rating Curve Plot for Crossing: Ebright Creek

## Total Rating Curve

Crossing: Ebright Creek



**Culvert Notes: Culvert 2**

**Table 2 - Culvert Summary Table: Culvert 2**

Total Discharge (cfs)	Culvert Discharge (cfs)	Headwater Elevation (ft)	Inlet Control Depth (ft)	Outlet Control Depth (ft)	Flow Type	Normal Depth (ft)	Critical Depth (ft)	Outlet Depth (ft)	Tailwater Depth (ft)	Outlet Velocity (ft/s)	Tailwater Velocity (ft/s)
0.51	0.51	45.45	0.018	5.000	7-M2c	0.012	0.012	0.012	0.096	3.166	1.024
21.14	450.23	45.45	5.000	0.103	1-S2n	3.074	3.171	3.083	0.843	10.430	3.752
41.77	450.22	45.45	5.000	4.082	1-S2n	3.074	3.171	3.083	1.222	10.430	4.590
62.41	450.16	45.45	4.999	4.081	1-S2n	3.074	3.170	3.083	1.512	10.430	5.145
83.04	450.22	45.45	5.000	4.082	1-S2n	3.074	3.171	3.083	1.753	10.430	5.568
103.67	450.22	45.45	5.000	4.082	1-S2n	3.074	3.171	3.083	1.963	10.430	5.915
124.30	450.22	45.45	5.000	4.082	1-S2n	3.074	3.171	3.083	2.151	10.430	6.212
144.93	450.22	45.45	5.000	4.082	1-S2n	3.074	3.171	3.083	2.322	10.430	6.472
145.27	450.22	45.45	5.000	4.082	1-S2n	3.074	3.171	3.083	2.325	10.430	6.476
186.20	450.21	45.45	5.000	4.082	1-S2n	3.074	3.171	3.083	2.626	10.430	6.916
206.83	450.13	45.45	4.999	4.081	1-S2n	3.074	3.170	3.083	2.763	10.430	7.110

\*\*\*\*\*

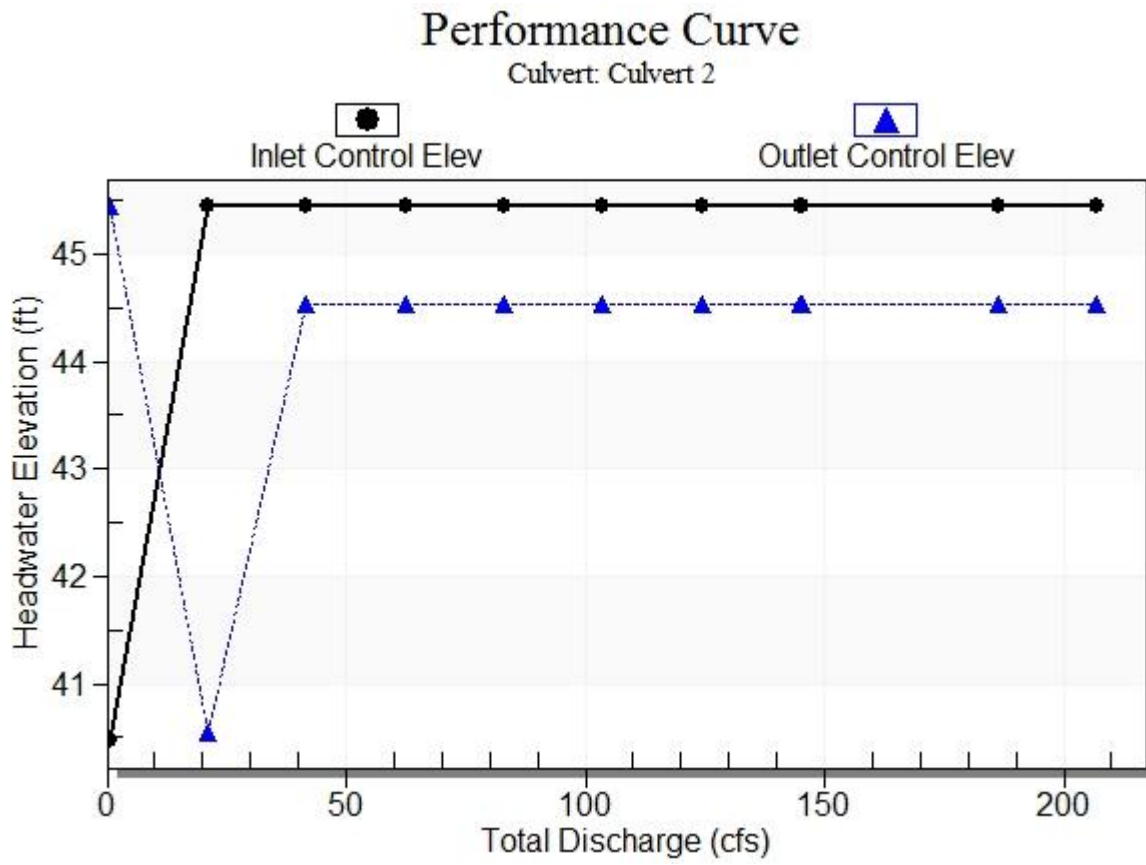
Straight Culvert

Inlet Elevation (invert): 40.45 ft, Outlet Elevation (invert): 40.10 ft

Culvert Length: 19.00 ft, Culvert Slope: 0.0184

\*\*\*\*\*

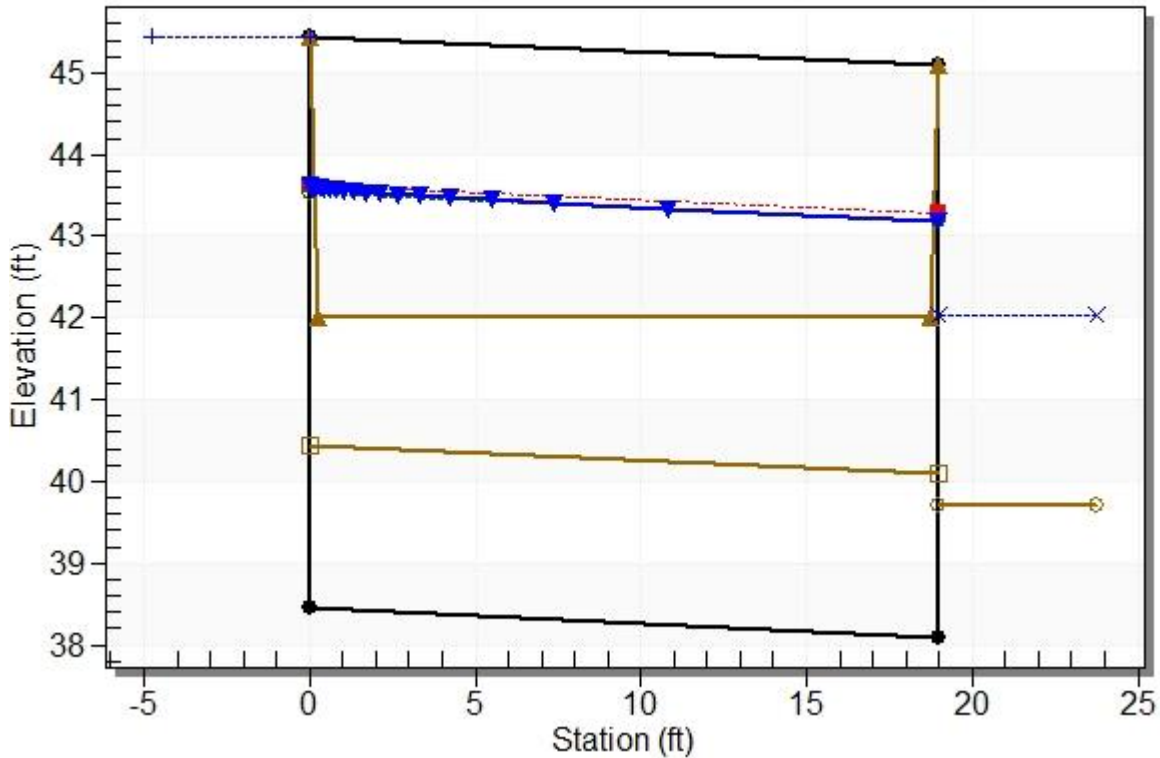
### Culvert Performance Curve Plot: Culvert 2



## Water Surface Profile Plot for Culvert: Culvert 2

Crossing - Ebright Creek, Design Discharge - 145.3 cfs

Culvert - Culvert 2, Culvert Discharge - 450.2 cfs



### Site Data - Culvert 2

Site Data Option: Culvert Invert Data

Inlet Station: 0.00 ft

Inlet Elevation: 38.45 ft

Outlet Station: 19.00 ft

Outlet Elevation: 38.10 ft

Number of Barrels: 1

### Culvert Data Summary - Culvert 2

Barrel Shape: Concrete Box

Barrel Span: 14.00 ft

Barrel Rise: 7.00 ft

Barrel Material: Concrete

Embedment: 24.00 in

Barrel Manning's n: 0.0120 (top and sides)

Manning's n: 0.0400 (bottom)



Culvert Type: Straight

Inlet Configuration: 1:1 Bevel Headwall

Flow (cfs)	Water Surface Elev (ft)	Depth (ft)	Velocity (ft/s)	Shear (psf)	Froude Number
0.51	39.81	0.10	1.02	0.11	0.59
21.14	40.55	0.84	3.75	0.97	0.81
41.77	40.93	1.22	4.59	1.40	0.84
62.41	41.22	1.51	5.14	1.74	0.87
83.04	41.46	1.75	5.57	2.01	0.88
103.67	41.67	1.96	5.92	2.25	0.89
124.30	41.86	2.15	6.21	2.47	0.90
144.93	42.03	2.32	6.47	2.67	0.91
145.27	42.03	2.32	6.48	2.67	0.91
186.20	42.34	2.63	6.92	3.02	0.92
206.83	42.47	2.76	7.11	3.17	0.93

Inlet Depression: NONE

### Table 3 - Downstream Channel Rating Curve (Crossing: Ebright Creek)

#### Tailwater Channel Data - Ebright Creek

Tailwater Channel Option: Trapezoidal Channel

Bottom Width: 5.00 ft

Side Slope (H:V): 2.00 (\_:1)

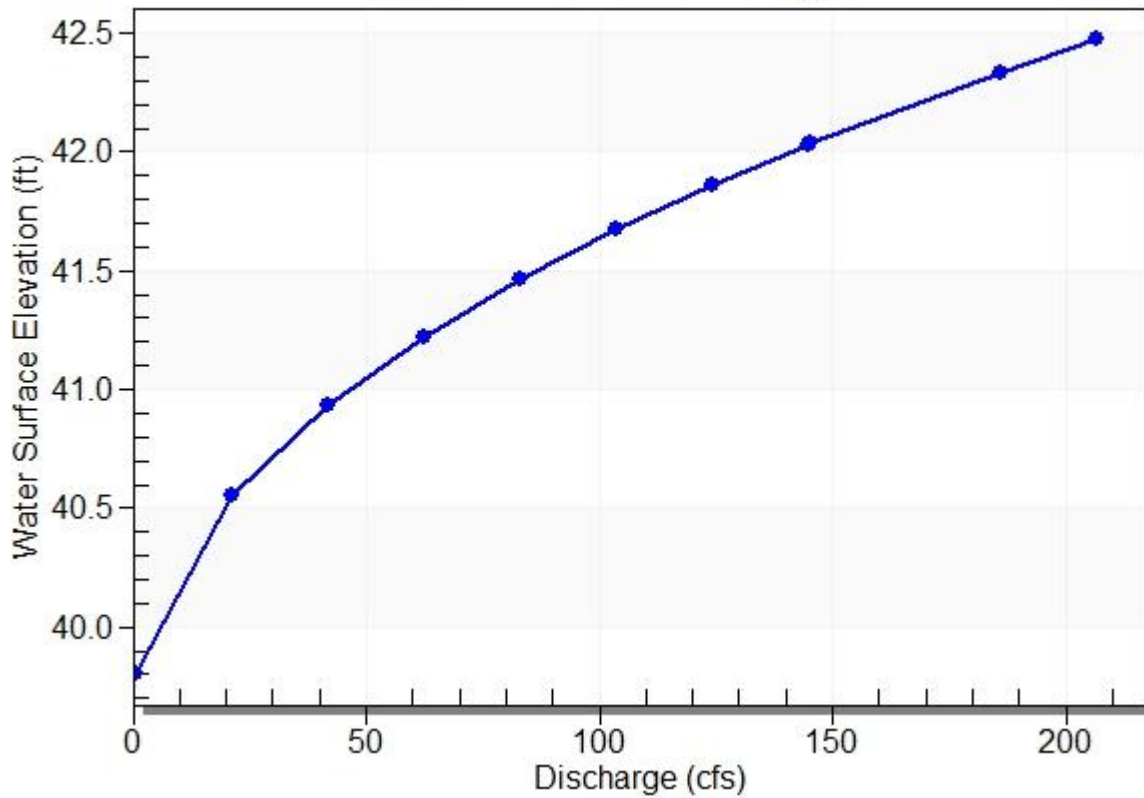
Channel Slope: 0.0184

Channel Manning's n: 0.0400

Channel Invert Elevation: 39.71 ft

### Tailwater Rating Curve Plot for Crossing: Ebright Creek

#### Downstream Channel Rating Curve



### Roadway Data for Crossing: Ebright Creek

Roadway Profile Shape: Constant Roadway Elevation

Crest Length: 100.00 ft

Crest Elevation: 42.00 ft

Roadway Surface: Paved

Roadway Top Width: 18.50 ft

# HY-8 Culvert Analysis Report

## Project Notes

Project Title: East Lake Sammamish Master Plan Trail - South Sammamish Segment B

Designer: Craig Buitrago

Project Date: Monday, August 01, 2016

Notes:

**Project Units: U.S. Customary Units**

**Outlet Control Option: Profiles**

**Exit Loss Option: Standard Method**

**Crossing Notes: Zaccuse Ck. Cul.1**

## Crossing Discharge Data

Discharge Selection Method: Specify Minimum, Design, and Maximum Flow

Minimum Flow: 0.1 cfs

Design Flow: 35.8 cfs

Maximum Flow: 54.6 cfs

Design Flow: 25-year discharge from MGSFlood

Maximum Flow: 100-year discharge from MGSFlood

Minimum Flow: Defined as low flow design discharge for ungaged streams according to King County 2016 Surface Water Design Manual

**Table 1 - Summary of Culvert Flows at Crossing: Zaccuse Ck. Cul.1**

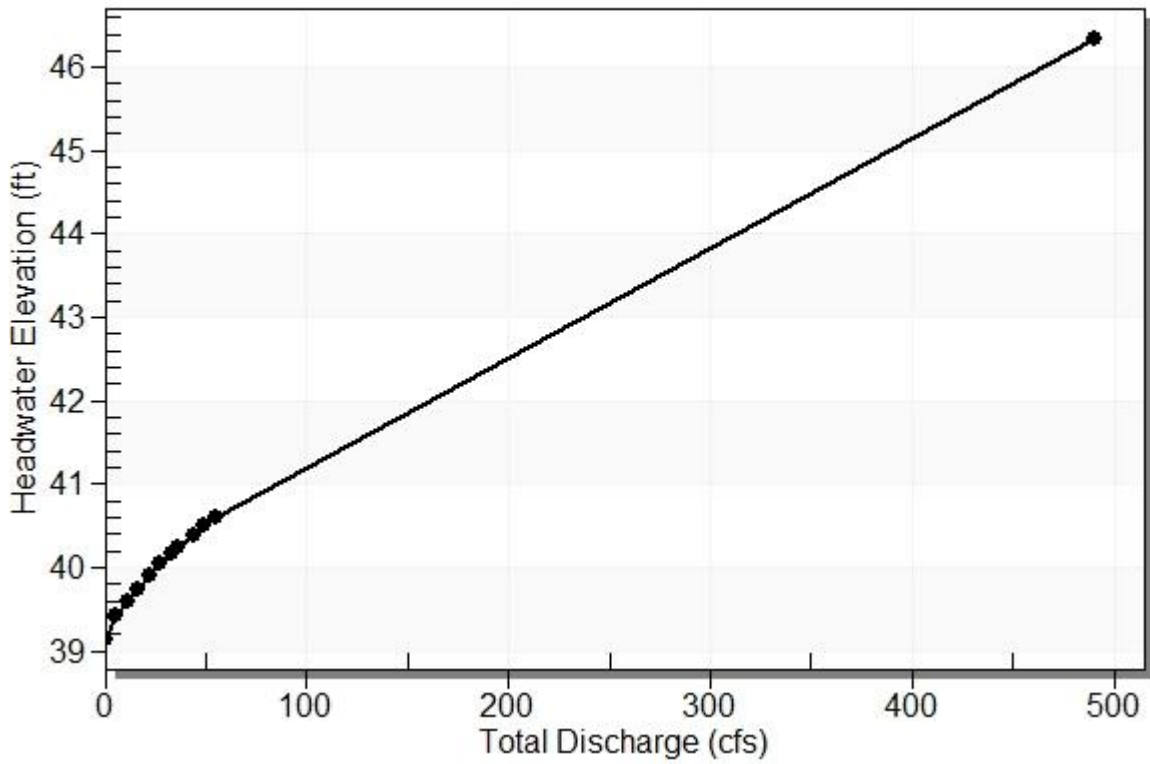
Headwater Elevation (ft)	Total Discharge (cfs)	Culvert 1 Discharge (cfs)	Roadway Discharge (cfs)	Iterations
39.14	0.10	0.10	0.00	1
39.43	5.55	5.55	0.00	1
39.60	11.00	11.00	0.00	1
39.74	16.45	16.45	0.00	1
39.90	21.90	21.90	0.00	1
40.06	27.35	27.35	0.00	1
40.17	32.80	32.80	0.00	1
40.24	35.80	35.80	0.00	1
40.39	43.70	43.70	0.00	1
40.50	49.15	49.15	0.00	1
40.59	54.60	54.60	0.00	1
46.00	490.09	490.09	0.00	Overtopping



**Rating Curve Plot for Crossing: Zaccuse Ck. Cul.1**

**Total Rating Curve**

Crossing: Zaccuse Ck. Cul.1



**Culvert Notes: Culvert 1**

**Table 2 - Culvert Summary Table: Culvert 1**

Total Discharge (cfs)	Culvert Discharge (cfs)	Headwater Elevation (ft)	Inlet Control Depth (ft)	Outlet Control Depth (ft)	Flow Type	Normal Depth (ft)	Critical Depth (ft)	Outlet Depth (ft)	Tailwater Depth (ft)	Outlet Velocity (ft/s)	Tailwater Velocity (ft/s)
0.10	0.10	39.14	0.005	0.0*	1-S2n	0.002	0.003	-1.#IO	0.034	0.002	0.714
5.55	5.55	39.43	0.292	0.0*	1-S2n	0.122	0.204	0.122	0.371	2.558	3.151
11.00	11.00	39.60	0.456	0.0*	1-S2n	0.242	0.328	0.242	0.549	2.919	3.930
16.45	16.45	39.74	0.600	0.0*	1-S2n	0.362	0.432	0.426	0.688	3.168	4.451
21.90	21.90	39.90	0.763	0.0*	1-S2n	0.482	0.520	0.482	0.805	4.070	4.849
27.35	27.35	40.06	0.917	0.0*	1-S2n	0.572	0.606	0.572	0.908	5.026	5.176
32.80	32.80	40.17	1.035	0.046	1-S2n	0.628	0.687	0.628	1.002	5.222	5.455
35.80	35.80	40.24	1.097	0.090	1-S2n	0.659	0.729	0.659	1.049	5.433	5.593
43.70	43.70	40.39	1.253	0.197	1-S2n	0.740	0.831	0.740	1.166	5.903	5.918
49.15	49.15	40.50	1.355	0.272	1-S2n	0.796	0.902	0.827	1.240	5.945	6.116
54.60	54.60	40.59	1.454	0.340	1-S2n	0.853	0.965	0.853	1.310	6.404	6.298

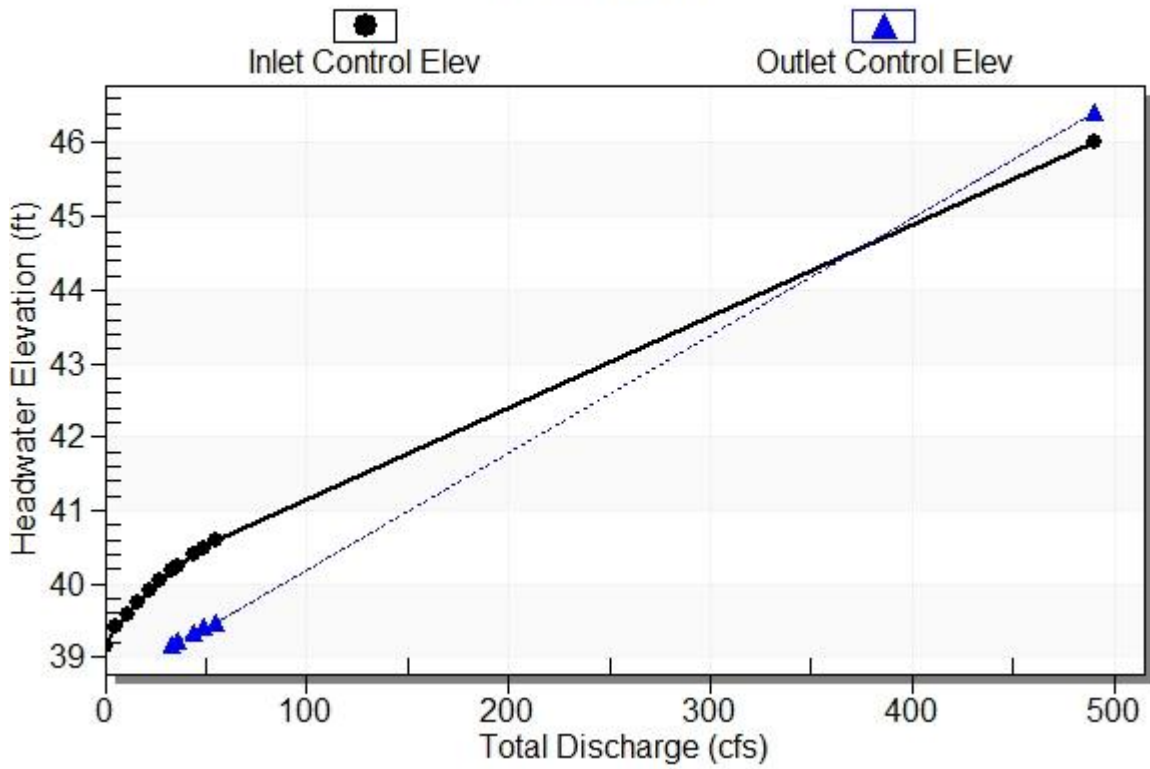
\* Full Flow Headwater elevation is below inlet invert.

```
*****  
                               Straight Culvert  
Inlet Elevation (invert): 39.14 ft,   Outlet Elevation (invert): 38.49 ft  
Culvert Length: 19.01 ft,   Culvert Slope: 0.0342  
*****
```

# Culvert Performance Curve Plot: Culvert 1

## Performance Curve

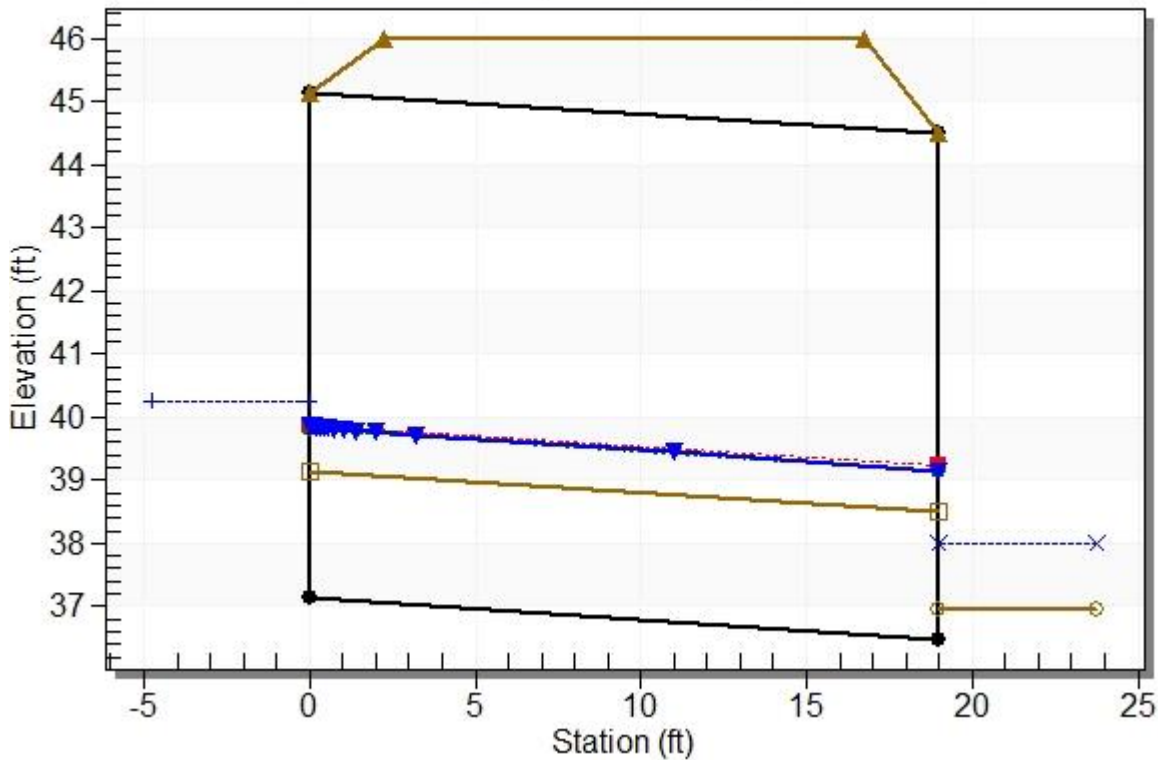
Culvert: Culvert 1



## Water Surface Profile Plot for Culvert: Culvert 1

Crossing - Zaccuse Ck. Cul.1, Design Discharge - 35.8 cfs

Culvert - Culvert 1, Culvert Discharge - 35.8 cfs



### Site Data - Culvert 1

Site Data Option: Culvert Invert Data

Inlet Station: 0.00 ft

Inlet Elevation: 37.14 ft

Outlet Station: 19.00 ft

Outlet Elevation: 36.49 ft

Number of Barrels: 1

### Culvert Data Summary - Culvert 1

Barrel Shape: Concrete Box

Barrel Span: 10.00 ft

Barrel Rise: 8.00 ft

Barrel Material: Concrete

Embedment: 24.00 in

Barrel Manning's n: 0.0120 (top and sides)

Manning's n: 0.0400 (bottom)



Culvert Type: Straight

Inlet Configuration: 1:1 Bevel Headwall

Flow (cfs)	Water Surface Elev (ft)	Depth (ft)	Velocity (ft/s)	Shear (psf)	Froude Number
0.10	36.97	0.03	0.71	0.07	0.68
5.55	37.31	0.37	3.15	0.79	0.98
11.00	37.49	0.55	3.93	1.17	1.03
16.45	37.63	0.69	4.45	1.46	1.06
21.90	37.75	0.81	4.85	1.71	1.08
27.35	37.85	0.91	5.18	1.93	1.10
32.80	37.94	1.00	5.45	2.13	1.11
35.80	37.99	1.05	5.59	2.23	1.12
43.70	38.11	1.17	5.92	2.48	1.13
49.15	38.18	1.24	6.12	2.64	1.14
54.60	38.25	1.31	6.30	2.79	1.15

Inlet Depression: NONE

### Table 3 - Downstream Channel Rating Curve (Crossing: Zaccuse Ck. Cul.1)

#### Tailwater Channel Data - Zaccuse Ck. Cul.1

Tailwater Channel Option: Trapezoidal Channel

Bottom Width: 4.00 ft

Side Slope (H:V): 2.00 (\_:1)

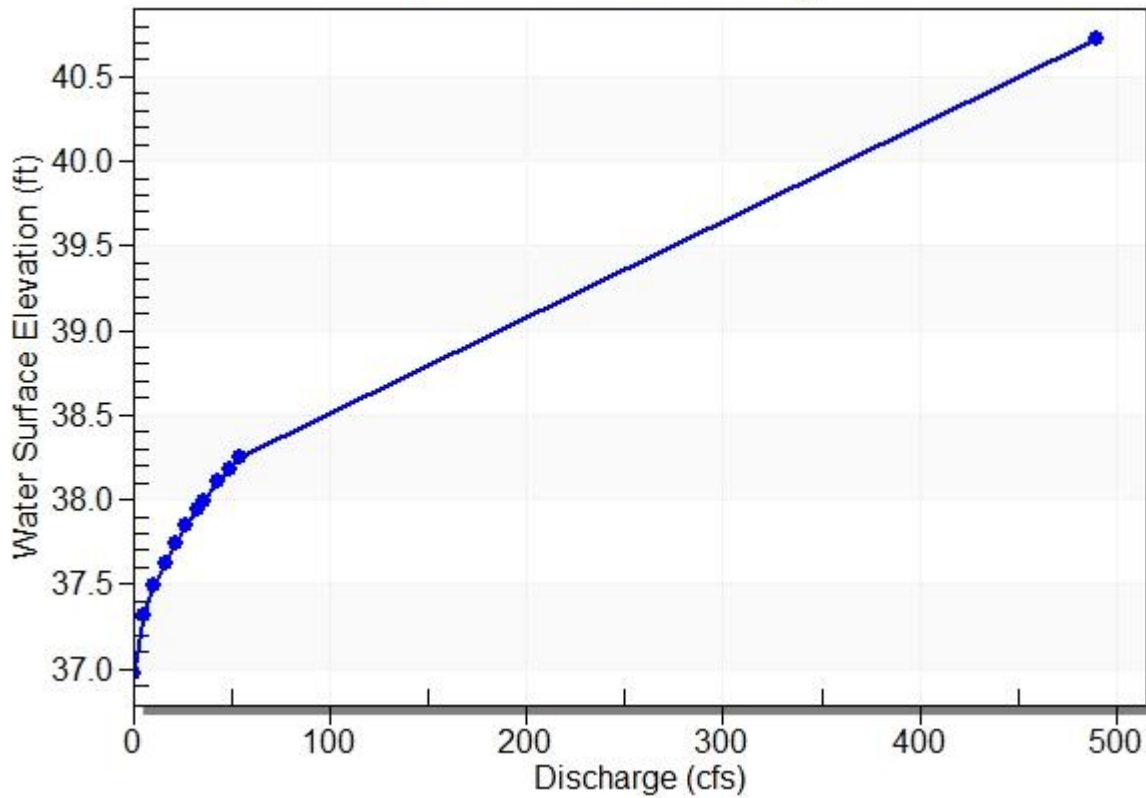
Channel Slope: 0.0341

Channel Manning's n: 0.0400

Channel Invert Elevation: 36.94 ft

### Tailwater Rating Curve Plot for Crossing: Zaccuse Ck. Cul.1

#### Downstream Channel Rating Curve



### Roadway Data for Crossing: Zaccuse Ck. Cul.1

Roadway Profile Shape: Constant Roadway Elevation

Crest Length: 100.00 ft

Crest Elevation: 46.00 ft

Roadway Surface: Paved

Roadway Top Width: 14.50 ft

# HY-8 Culvert Analysis Report

## Project Notes

Project Title: East Lake Sammamish Master Plan Trail - South Sammamish Segment B

Designer: Craig Buitrago

Project Date: Monday, August 01, 2016

Notes:

**Project Units: U.S. Customary Units**

**Outlet Control Option: Profiles**

**Exit Loss Option: Standard Method**

**Crossing Notes: Zaccuse Ck. Cul.2**

## Crossing Discharge Data

Discharge Selection Method: Specify Minimum, Design, and Maximum Flow

Minimum Flow: 0.1 cfs

Design Flow: 35.81 cfs

Maximum Flow: 54.59 cfs

Design Flow: 25-year discharge from MGSFlood

Maximum Flow: 100-year discharge from MGSFlood

Minimum Flow: Defined as low flow design discharge for ungaged streams according to King County 2016 Surface Water Design Manual

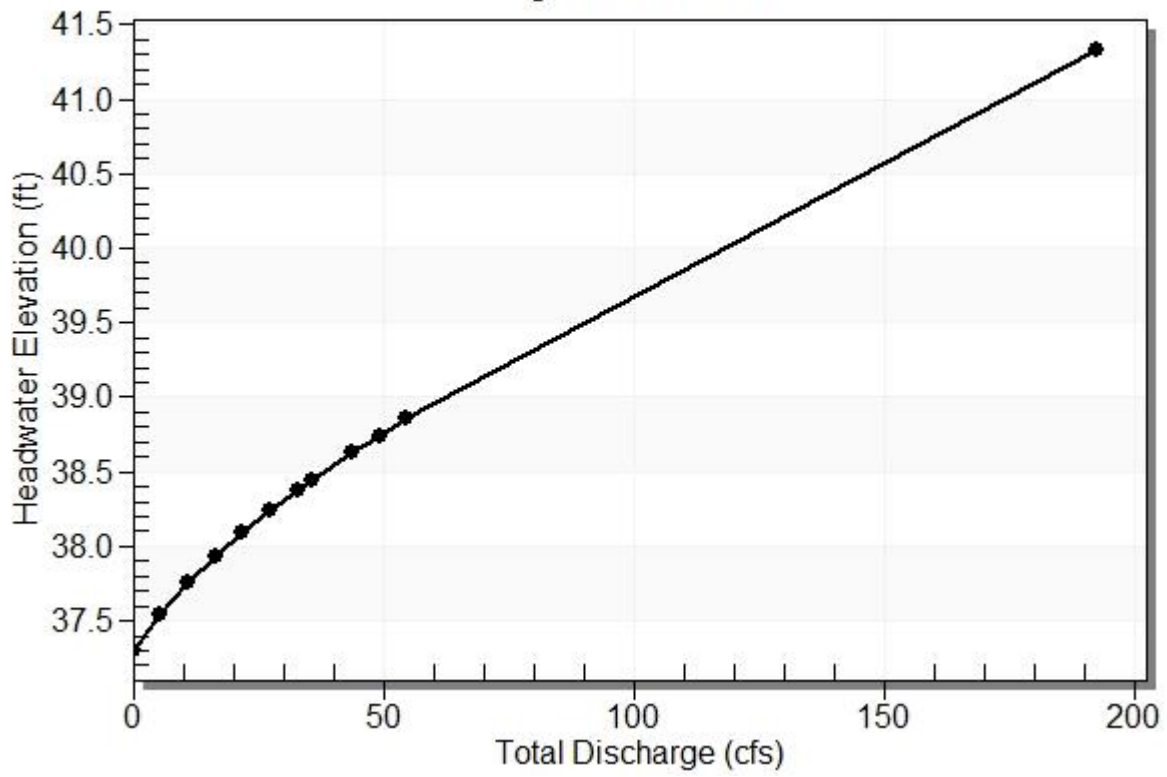
**Table 1 - Summary of Culvert Flows at Crossing: Zaccuse Ck. Cul.2**

Headwater Elevation (ft)	Total Discharge (cfs)	Culvert 2 Discharge (cfs)	Roadway Discharge (cfs)	Iterations
37.31	0.10	0.10	0.00	1
37.55	5.55	5.55	0.00	1
37.76	11.00	11.00	0.00	1
37.93	16.45	16.45	0.00	1
38.09	21.90	21.90	0.00	1
38.24	27.34	27.34	0.00	1
38.37	32.79	32.79	0.00	1
38.44	35.81	35.81	0.00	1
38.62	43.69	43.69	0.00	1
38.74	49.14	49.14	0.00	1
38.86	54.59	54.59	0.00	1
41.00	192.40	192.40	0.00	Overtopping

**Rating Curve Plot for Crossing: Zaccuse Ck. Cul.2**

**Total Rating Curve**

Crossing: Zaccuse Ck. Cul.2



**Culvert Notes: Culvert 2**



**Table 2 - Culvert Summary Table: Culvert 2**

Total Discharge (cfs)	Culvert Discharge (cfs)	Headwater Elevation (ft)	Inlet Control Depth (ft)	Outlet Control Depth (ft)	Flow Type	Normal Depth (ft)	Critical Depth (ft)	Outlet Depth (ft)	Tailwater Depth (ft)	Outlet Velocity (ft/s)	Tailwater Velocity (ft/s)
0.10	0.10	37.31	0.006	0.126	3-M1t	0.004	0.004	0.204	0.034	0.049	0.714
5.55	5.55	37.55	0.284	0.366	3-M1t	0.243	0.201	0.541	0.371	1.025	3.150
11.00	11.00	37.76	0.507	0.576	3-M1t	0.369	0.327	0.719	0.549	1.530	3.930
16.45	16.45	37.93	0.662	0.753	3-M1t	0.480	0.430	0.858	0.688	1.918	4.450
21.90	21.90	38.09	0.801	0.911	3-M1t	0.577	0.525	0.975	0.805	2.246	4.849
27.34	27.34	38.24	0.929	1.056	3-M1t	0.655	0.619	1.078	0.908	2.536	5.176
32.79	32.79	38.37	1.048	1.192	3-M1t	0.733	0.700	1.171	1.001	2.799	5.455
35.81	35.81	38.44	1.112	1.264	3-M1t	0.777	0.743	1.220	1.050	2.936	5.594
43.69	43.69	38.62	1.269	1.443	3-M1t	0.875	0.845	1.336	1.166	3.270	5.918
49.14	49.14	38.74	1.373	1.561	3-M1t	0.938	0.915	1.410	1.240	3.485	6.116
54.59	54.59	38.86	1.473	1.675	3-M1t	1.000	0.981	1.480	1.310	3.690	6.298

\*\*\*\*\*

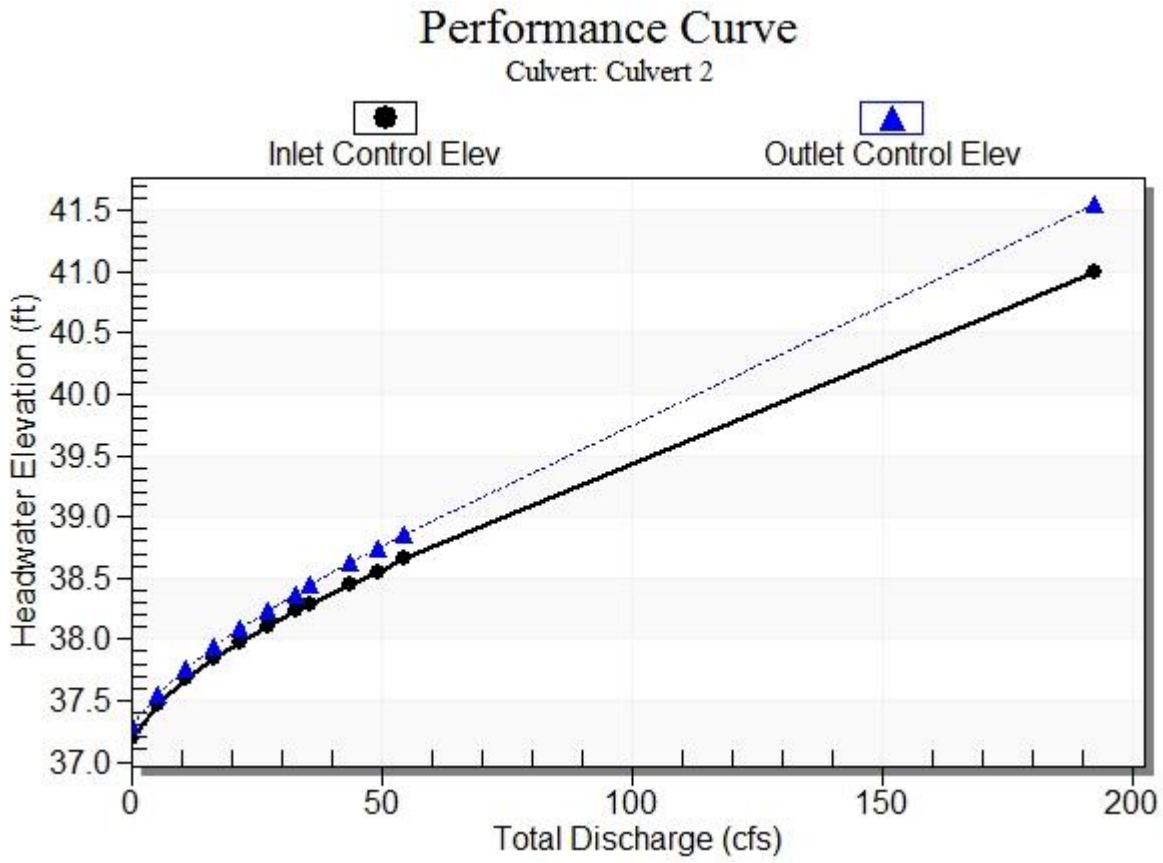
Straight Culvert

Inlet Elevation (invert): 37.18 ft, Outlet Elevation (invert): 36.77 ft

Culvert Length: 19.00 ft, Culvert Slope: 0.0216

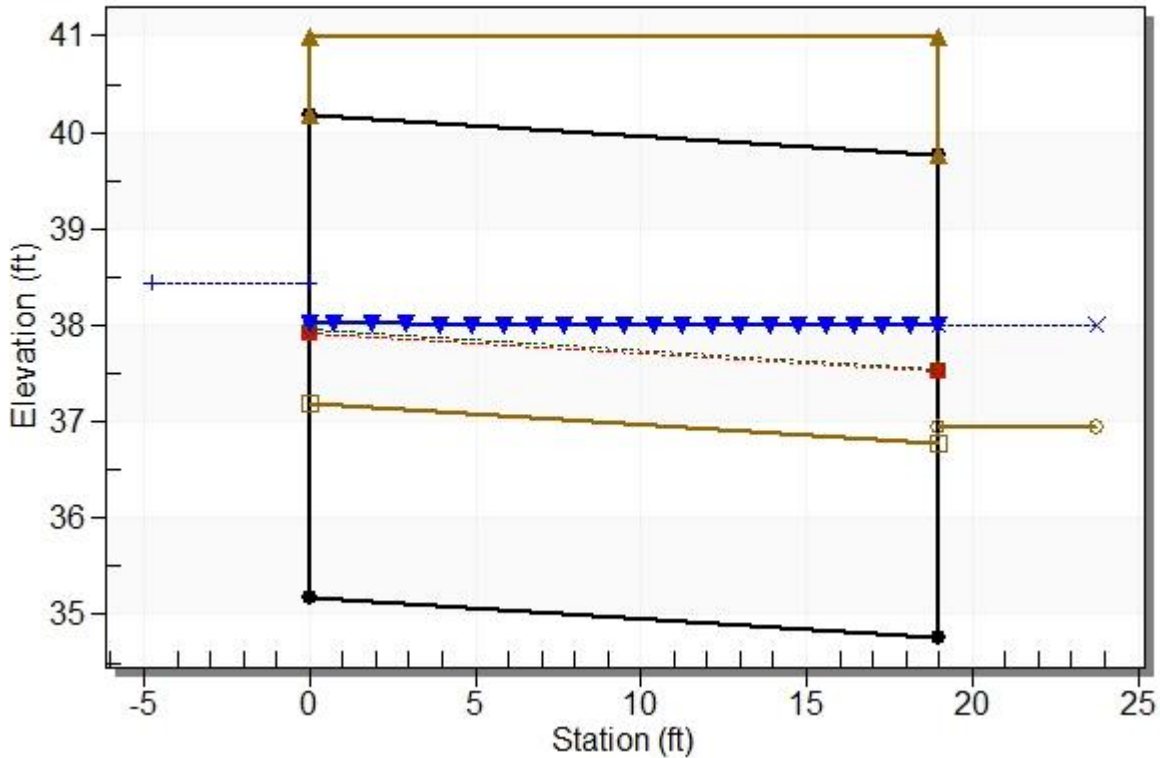
\*\*\*\*\*

### Culvert Performance Curve Plot: Culvert 2



## Water Surface Profile Plot for Culvert: Culvert 2

Crossing - Zaccuse Ck. Cul.2, Design Discharge - 35.8 cfs  
Culvert - Culvert 2, Culvert Discharge - 35.8 cfs



### Site Data - Culvert 2

Site Data Option: Culvert Invert Data

Inlet Station: 0.00 ft

Inlet Elevation: 35.18 ft

Outlet Station: 19.00 ft

Outlet Elevation: 34.77 ft

Number of Barrels: 1

### Culvert Data Summary - Culvert 2

Barrel Shape: Concrete Box

Barrel Span: 10.00 ft

Barrel Rise: 5.00 ft

Barrel Material: Concrete

Embedment: 24.00 in

Barrel Manning's n: 0.0120 (top and sides)

Manning's n: 0.0400 (bottom)

Culvert Type: Straight

Inlet Configuration: 1:1 Bevel Headwall

Flow (cfs)	Water Surface Elev (ft)	Depth (ft)	Velocity (ft/s)	Shear (psf)	Froude Number
0.10	36.97	0.03	0.71	0.07	0.68
5.55	37.31	0.37	3.15	0.79	0.98
11.00	37.49	0.55	3.93	1.17	1.03
16.45	37.63	0.69	4.45	1.46	1.06
21.90	37.74	0.80	4.85	1.71	1.08
27.34	37.85	0.91	5.18	1.93	1.10
32.79	37.94	1.00	5.45	2.13	1.11
35.81	37.99	1.05	5.59	2.23	1.12
43.69	38.11	1.17	5.92	2.48	1.13
49.14	38.18	1.24	6.12	2.64	1.14
54.59	38.25	1.31	6.30	2.79	1.15

Inlet Depression: NONE

**Table 3 - Downstream Channel Rating Curve (Crossing: Zaccuse Ck. Cul.2)**

**Tailwater Channel Data - Zaccuse Ck. Cul.2**

Tailwater Channel Option: Trapezoidal Channel

Bottom Width: 4.00 ft

Side Slope (H:V): 2.00 (\_:1)

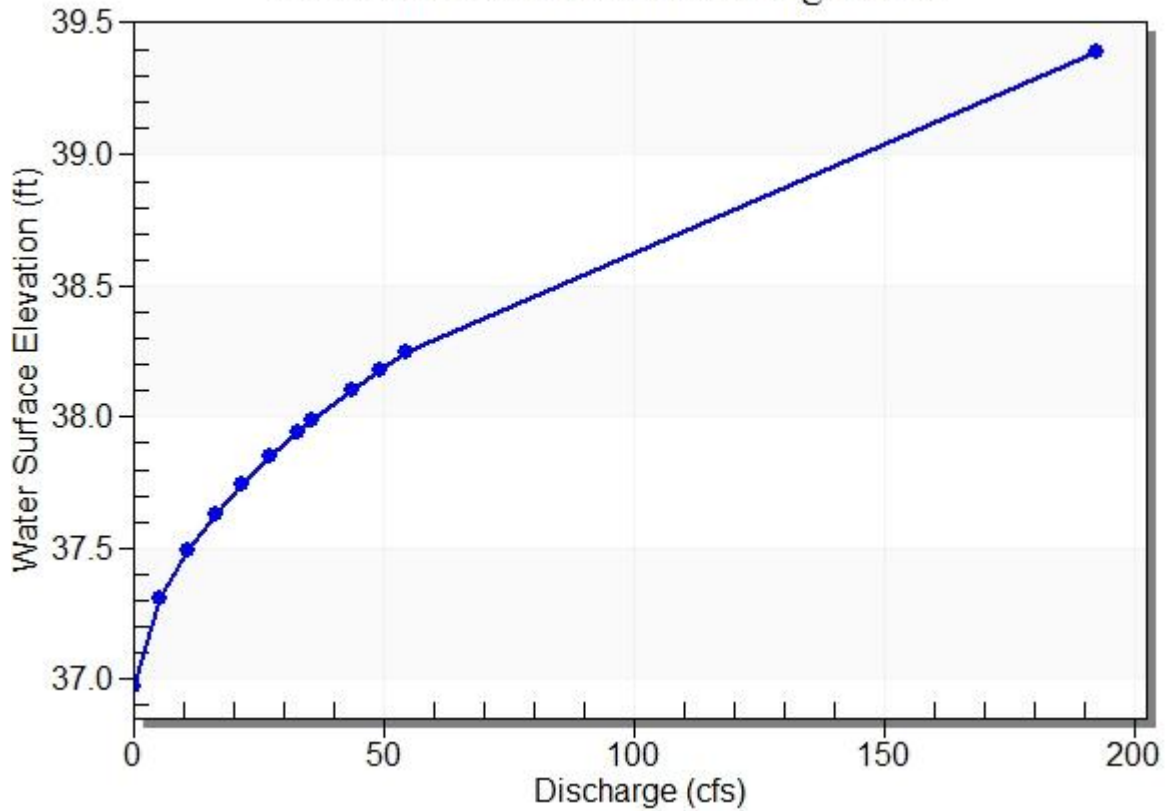
Channel Slope: 0.0341

Channel Manning's n: 0.0400

Channel Invert Elevation: 36.94 ft

**Tailwater Rating Curve Plot for Crossing: Zaccuse Ck. Cul.2**

**Downstream Channel Rating Curve**



**Roadway Data for Crossing: Zaccuse Ck. Cul.2**

Roadway Profile Shape: Constant Roadway Elevation

Crest Length: 100.00 ft

Crest Elevation: 41.00 ft

Roadway Surface: Paved

Roadway Top Width: 19.00 ft



# HY-8 Culvert Analysis Report

## Project Notes

Project Title: East Lake Sammamish Master Plan Trail - South Sammamish Segment B

Designer: Craig Buitrago

Project Date: Monday, August 01, 2016

Notes:

**Project Units: U.S. Customary Units**

**Outlet Control Option: Profiles**

**Exit Loss Option: Standard Method**

**Crossing Notes: George Davis Creek**

## Crossing Discharge Data

Discharge Selection Method: Specify Minimum, Design, and Maximum Flow

Minimum Flow: 1 cfs

Design Flow: 484.93 cfs

Maximum Flow: 741.98 cfs

**Design Flow:** 25-year discharge from MGSFlood

**Maximum Flow:** 100-year discharge from MGSFlood

**Minimum Flow:** Defined as low flow design discharge for ungaged streams according to King County 2016 Surface Water Design Manual

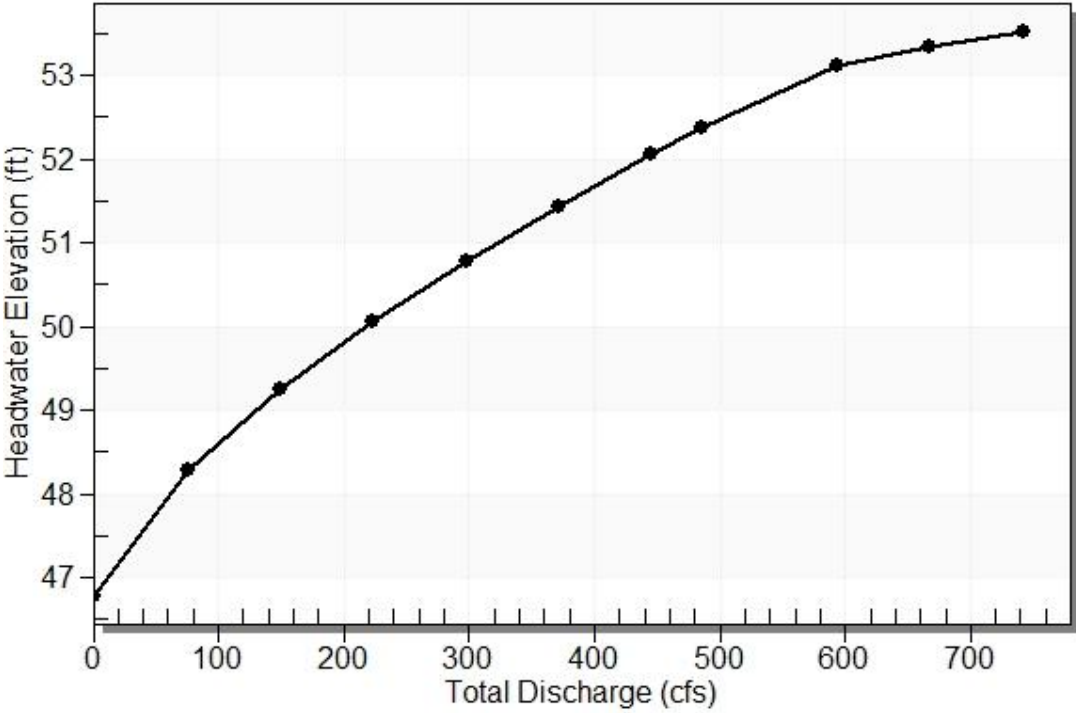
**Table 1 - Summary of Culvert Flows at Crossing: George Davies**

Headwater Elevation (ft)	Total Discharge (cfs)	Culvert 2 Discharge (cfs)	Roadway Discharge (cfs)	Iterations
46.79	1.00	1.00	0.00	1
48.29	75.10	75.10	0.00	1
49.25	149.20	149.20	0.00	1
50.05	223.29	223.29	0.00	1
50.77	297.39	297.39	0.00	1
51.44	371.49	371.49	0.00	1
52.06	445.59	445.59	0.00	1
52.38	484.93	484.93	0.00	1
53.13	593.78	580.70	13.02	6
53.34	667.88	607.31	60.28	5
53.53	741.98	623.78	118.06	5
53.00	564.17	564.17	0.00	Overtopping

**Rating Curve Plot for Crossing: George Davies**

**Total Rating Curve**

Crossing: George Davies



**Culvert Notes: Culvert 2**

**Table 2 - Culvert Summary Table: Culvert 2**

Total Discharge (cfs)	Culvert Discharge (cfs)	Headwater Elevation (ft)	Inlet Control Depth (ft)	Outlet Control Depth (ft)	Flow Type	Normal Depth (ft)	Critical Depth (ft)	Outlet Depth (ft)	Tailwater Depth (ft)	Outlet Velocity (ft/s)	Tailwater Velocity (ft/s)
1.00	1.00	46.79	0.034	0.159	2-M2c	0.030	0.022	0.022	0.146	3.239	1.087
75.10	75.10	48.29	1.471	1.661	2-M2c	1.192	0.964	0.964	1.733	5.564	4.578
149.20	149.20	49.25	2.324	2.615	2-M2c	1.823	1.527	1.527	2.467	6.978	5.530
223.29	223.29	50.05	3.040	3.421	2-M2c	2.320	1.997	1.997	3.015	7.988	6.158
297.39	297.39	50.77	3.725	4.144	2-M2c	2.757	2.416	2.416	3.464	8.792	6.640
371.49	371.49	51.44	4.323	4.810	2-M2c	3.151	2.791	2.791	3.853	9.508	7.035
445.59	445.59	52.06	4.968	5.435	7-M2c	3.512	3.149	3.149	4.198	10.107	7.374
484.93	484.93	52.38	5.383	5.753	7-M2c	3.697	3.335	3.335	4.367	10.388	7.537
593.78	580.70	53.13	6.405	6.495	7-M2c	4.121	3.761	3.761	4.797	11.028	7.939
667.88	607.31	53.34	6.713	6.694	7-M2c	4.231	3.875	3.875	5.063	11.195	8.181
741.98	623.78	53.53	6.904	6.816	7-M2c	4.299	3.944	3.944	5.312	11.297	8.403

\*\*\*\*\*

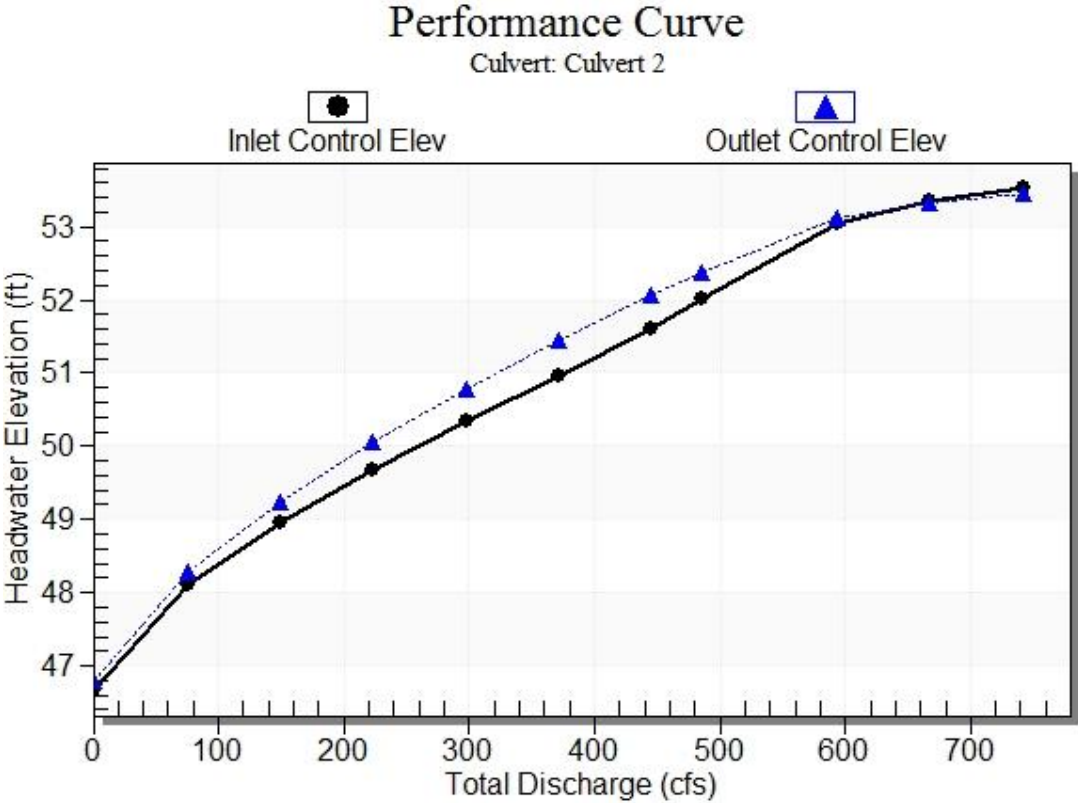
Straight Culvert

Inlet Elevation (invert): 46.63 ft, Outlet Elevation (invert): 46.41 ft

Culvert Length: 19.00 ft, Culvert Slope: 0.0116

\*\*\*\*\*

Culvert Performance Curve Plot: Culvert 2







Culvert Type: Straight

Inlet Configuration: 1:1 Bevel Headwall

Flow (cfs)	Water Surface Elev (ft)	Depth (ft)	Velocity (ft/s)	Shear (psf)	Froude Number
1.00	44.56	0.15	1.09	0.11	0.51
75.10	46.14	1.73	4.58	1.30	0.72
149.20	46.88	2.47	5.53	1.85	0.75
223.29	47.42	3.01	6.16	2.26	0.77
297.39	47.87	3.46	6.64	2.59	0.78
371.49	48.26	3.85	7.04	2.88	0.79
445.59	48.61	4.20	7.37	3.14	0.80
484.93	48.78	4.37	7.54	3.27	0.80
593.78	49.21	4.80	7.94	3.59	0.81
667.88	49.47	5.06	8.18	3.79	0.82
741.98	49.72	5.31	8.40	3.98	0.82

Inlet Depression: NONE

### Table 3 - Downstream Channel Rating Curve (Crossing: George Davies)

#### Tailwater Channel Data - George Davies

Tailwater Channel Option: Trapezoidal Channel

Bottom Width: 6.00 ft

Side Slope (H:V): 2.00 (\_:1)

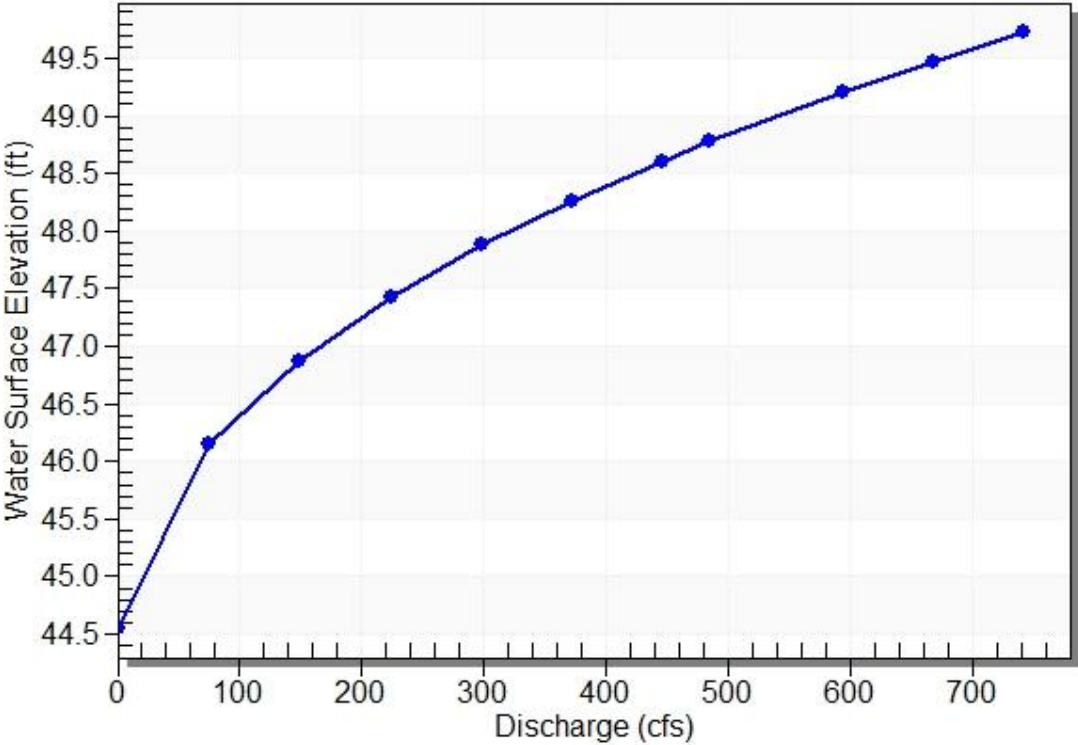
Channel Slope: 0.0120

Channel Manning's n: 0.0400

Channel Invert Elevation: 44.41 ft

**Tailwater Rating Curve Plot for Crossing: George Davies**

**Downstream Channel Rating Curve**



**Roadway Data for Crossing: George Davies**

- Roadway Profile Shape: Constant Roadway Elevation
- Crest Length: 100.00 ft
- Crest Elevation: 53.00 ft
- Roadway Surface: Paved
- Roadway Top Width: 18.50 ft

# HY-8 Culvert Analysis Report

## Project Notes

Project Title: East Lake Sammamish Master Plan Trail - South Sammamish Segment B

Designer: Craig Buitrago

Project Date: Monday, August 01, 2016

Notes:

**Project Units: U.S. Customary Units**

**Outlet Control Option: Profiles**

**Exit Loss Option: Standard Method**

**Crossing Notes: 0143L Creek**

## Crossing Discharge Data

Discharge Selection Method: Specify Minimum, Design, and Maximum Flow

Minimum Flow: 0.06 cfs

Design Flow: 28.69 cfs

Maximum Flow: 45.15 cfs

**Design Flow:** 25-year discharge from MGSFlood

**Maximum Flow:** 100-year discharge from MGSFlood

**Minimum Flow:** Defined as low flow design discharge for ungaged streams according to King County 2016 Surface Water Design Manual

**Table 1 - Summary of Culvert Flows at Crossing: 0143L Creek**

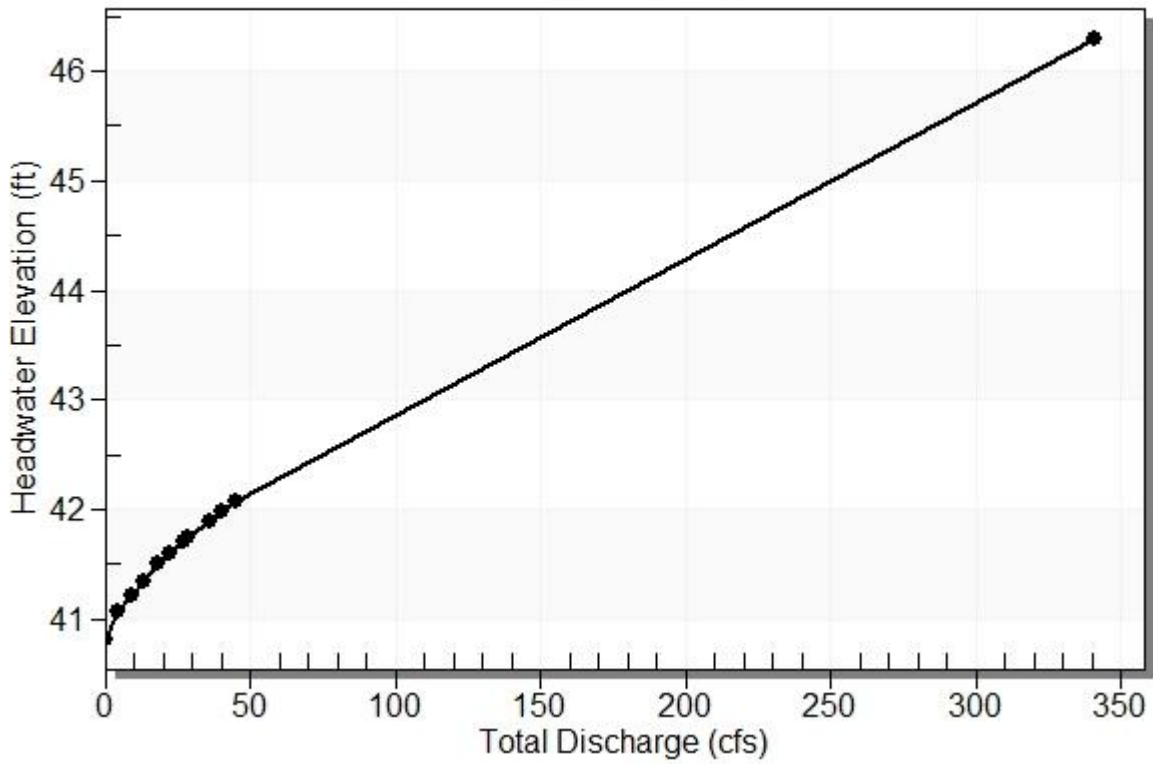
Headwater Elevation (ft)	Total Discharge (cfs)	Culvert 2 Discharge (cfs)	Roadway Discharge (cfs)	Iterations
40.82	0.06	0.06	0.00	1
41.08	4.57	4.57	0.00	1
41.21	9.08	9.08	0.00	1
41.34	13.59	13.59	0.00	1
41.50	18.10	18.10	0.00	1
41.61	22.60	22.60	0.00	1
41.71	27.11	27.11	0.00	1
41.74	28.69	28.69	0.00	1
41.90	36.13	36.13	0.00	1
41.98	40.64	40.64	0.00	1
42.07	45.15	45.15	0.00	1
46.00	340.74	340.74	0.00	Overtopping



**Rating Curve Plot for Crossing: 0143L Creek**

**Total Rating Curve**

Crossing: 0143L Creek



**Culvert Notes: Culvert 2**

**Table 2 - Culvert Summary Table: Culvert 2**

Total Discharge (cfs)	Culvert Discharge (cfs)	Headwater Elevation (ft)	Inlet Control Depth (ft)	Outlet Control Depth (ft)	Flow Type	Normal Depth (ft)	Critical Depth (ft)	Outlet Depth (ft)	Tailwater Depth (ft)	Outlet Velocity (ft/s)	Tailwater Velocity (ft/s)
0.06	0.06	40.82	0.003	0.0*	1-S2n	0.001	0.002	-1.#IO	0.032	0.001	0.898
4.57	4.57	41.08	0.257	0.0*	1-S2n	0.086	0.180	0.167	0.404	1.678	4.029
9.08	9.08	41.21	0.393	0.0*	1-S2n	0.171	0.284	0.250	0.584	2.505	4.911
13.59	13.59	41.34	0.522	0.0*	1-S2n	0.256	0.376	0.256	0.719	3.697	5.492
18.10	18.10	41.50	0.680	0.0*	1-S2n	0.341	0.459	0.341	0.832	4.248	5.937
22.60	22.60	41.61	0.787	0.0*	1-S2n	0.425	0.535	0.425	0.930	4.994	6.301
27.11	27.11	41.71	0.888	0.0*	1-S2n	0.481	0.606	0.481	1.017	5.985	6.612
28.69	28.69	41.74	0.922	0.0*	1-S2n	0.494	0.625	0.494	1.045	6.361	6.710
36.13	36.13	41.90	1.076	0.0*	1-S2n	0.560	0.734	0.560	1.169	6.456	7.129
40.64	40.64	41.98	1.163	0.0*	1-S2n	0.599	0.792	0.599	1.236	6.782	7.351
45.15	45.15	42.07	1.248	0.0*	1-S2n	0.639	0.853	0.639	1.299	7.068	7.555

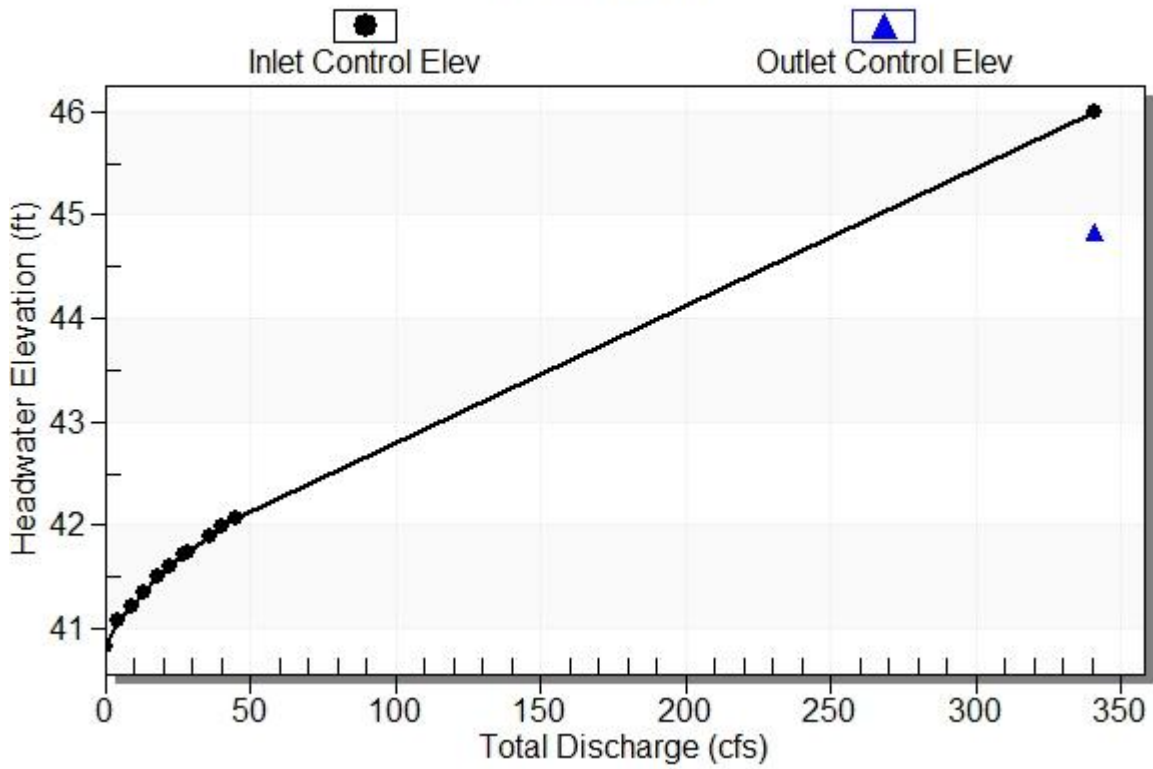
\* Full Flow Headwater elevation is below inlet invert.

\*\*\*\*\*  
Straight Culvert  
Inlet Elevation (invert): 40.82 ft, Outlet Elevation (invert): 39.69 ft  
Culvert Length: 19.03 ft, Culvert Slope: 0.0595  
\*\*\*\*\*

### Culvert Performance Curve Plot: Culvert 2

## Performance Curve

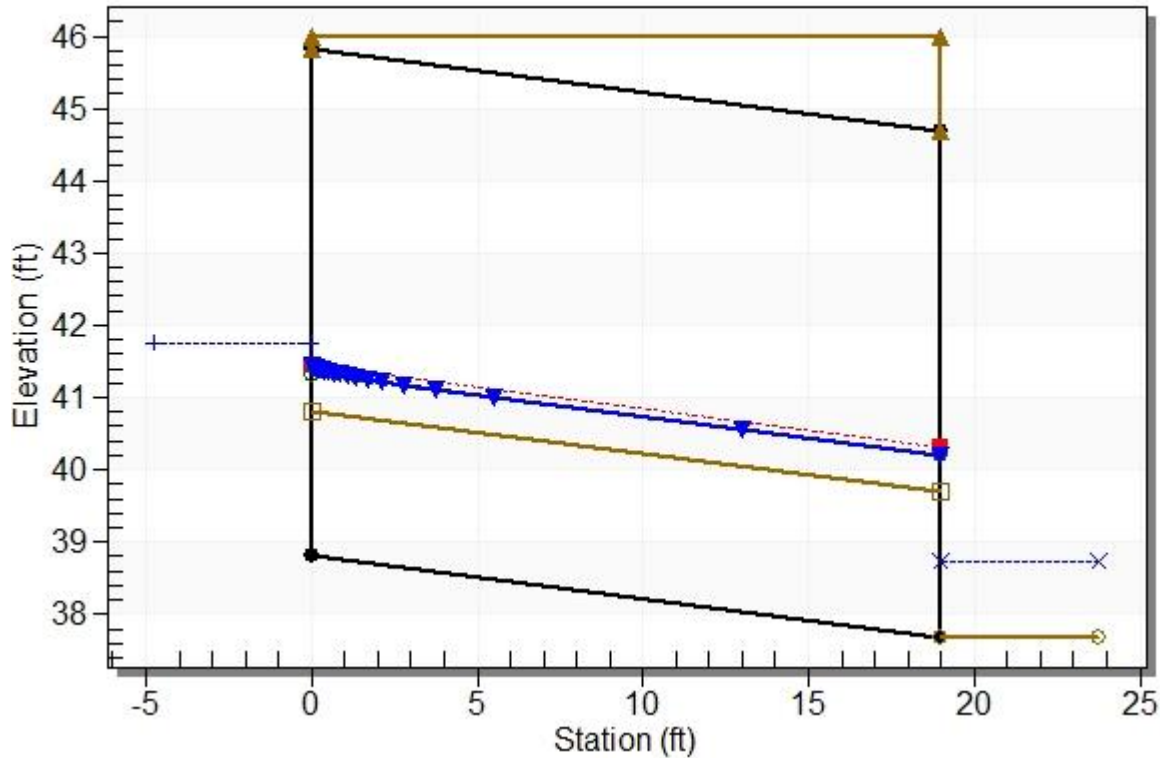
Culvert: Culvert 2



## Water Surface Profile Plot for Culvert: Culvert 2

Crossing - 0143L Creek, Design Discharge - 28.7 cfs

Culvert - Culvert 2, Culvert Discharge - 28.7 cfs



### Site Data - Culvert 2

Site Data Option: Culvert Invert Data

Inlet Station: 0.00 ft

Inlet Elevation: 38.82 ft

Outlet Station: 19.00 ft

Outlet Elevation: 37.69 ft

Number of Barrels: 1

### Culvert Data Summary - Culvert 2

Barrel Shape: Concrete Box

Barrel Span: 10.00 ft

Barrel Rise: 7.00 ft

Barrel Material: Concrete

Embedment: 24.00 in

Barrel Manning's n: 0.0120 (top and sides)

Manning's n: 0.0400 (bottom)



Culvert Type: Straight

Inlet Configuration: 1:1 Bevel Headwall

Flow (cfs)	Water Surface Elev (ft)	Depth (ft)	Velocity (ft/s)	Shear (psf)	Froude Number
0.06	37.72	0.03	0.90	0.12	0.89
4.57	38.09	0.40	4.03	1.49	1.27
9.08	38.27	0.58	4.91	2.15	1.33
13.59	38.41	0.72	5.49	2.65	1.36
18.10	38.52	0.83	5.94	3.07	1.38
22.60	38.62	0.93	6.30	3.43	1.40
27.11	38.71	1.02	6.61	3.75	1.42
28.69	38.74	1.05	6.71	3.85	1.42
36.13	38.86	1.17	7.13	4.31	1.44
40.64	38.93	1.24	7.35	4.56	1.45
45.15	38.99	1.30	7.56	4.79	1.46

Inlet Depression: NONE

### Table 3 - Downstream Channel Rating Curve (Crossing: 0143L Creek)

#### Tailwater Channel Data - 0143L Creek

Tailwater Channel Option: Trapezoidal Channel

Bottom Width: 2.00 ft

Side Slope (H:V): 2.00 (\_:1)

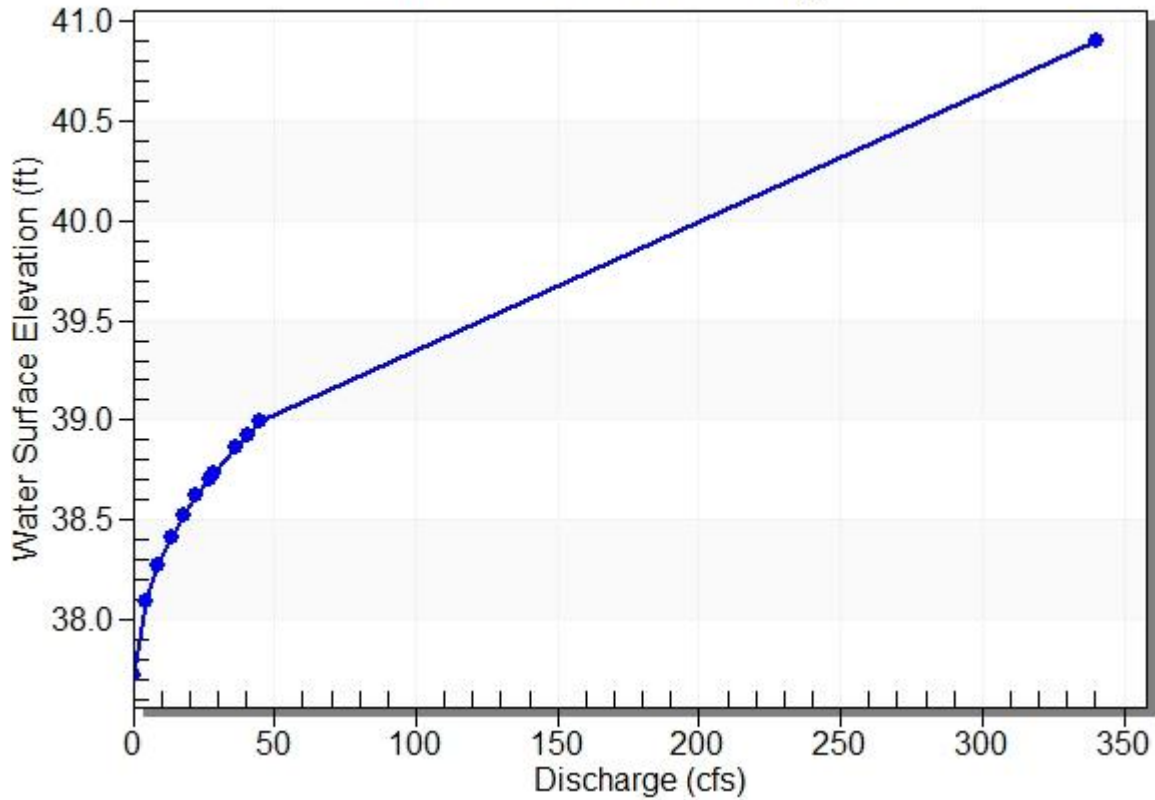
Channel Slope: 0.0591

Channel Manning's n: 0.0400

Channel Invert Elevation: 37.69 ft

### Tailwater Rating Curve Plot for Crossing: 0143L Creek

#### Downstream Channel Rating Curve



### Roadway Data for Crossing: 0143L Creek

Roadway Profile Shape: Constant Roadway Elevation

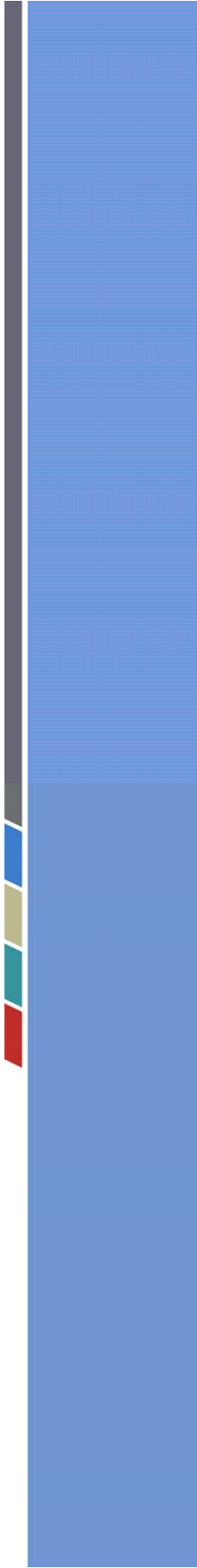
Crest Length: 100.00 ft

Crest Elevation: 46.00 ft

Roadway Surface: Paved

Roadway Top Width: 19.00 ft

## C4 – Conveyance Calculations





**STORM SEWER DESIGN (English Units)**

This spreadsheet accomplishes a storm sewer design using the rational method. Enter the data in the non-shaded areas only. Please use one spreadsheet per stormsewer run.

Project Name: **EAST LAKE SAMMAMISH TRAIL - SOUTH SAMMAMISH SEGMENT B**

Designed By: **CAB, 5/27/2016**  
Project Office: **N/A**

m = **6.89**    n = **0.539**    Design Storm Event = **25**    Pavement thickness (ft) = **0.33333**    Pipe Thickness (inches) = **1.25**

Location		Discharge													Drain Design										Drain Profile				Remarks		
Drain Located On	From Sta.	To Sta.	Source of Drainage	Drainage Area A (acre)	Runoff Coeff. C	CA (acre)	Sum (acre)	Tc Across Area (minutes)	Total Tc = Col. 8a + Tc across pipe length (minutes)	Rainfall Intensity (in/hr)	Runoff (cfs)	Contrib. Inflow (cfs)	Total Flow (cfs)	Pipe Dia. (in)	Manning roughness coefficient "n"	Pipe Slope (ft/ft)	Velocity Of Flow (ft/s)	Pipe Capacity (cfs)	Pipe Velocity Check (Desirable Minimum 3 ft/sec; Desirable Maximum 10 ft/sec for Column 16)	Pipe Capacity Check (Column 13 vs. Column 17)	Pipe Length*** (ft)	Elevation Change (ft)	Upstr. Invert Elev. (ft)	Downstr. Invert Elev. (ft)	Upstr. Ground Elev. (ft)	Downstr. Ground Elev. (ft)	Upstr. Pipe Cover (ft)	Downstr. Pipe Cover (ft)	Upstr. Pipe Cover Check (ft)	Downstr. Pipe Cover Check (ft)	Remarks
1	2	3	4	5	6	7	8	8a	9	10	11	12	13	14	14a	15	16	17	17a	17b	18	19	20	21	22	23	24	25	26	27	28
ELST	29843	29819	Pavement	0.01	0.90	0.01	0.01	5.0	5.0	2.89	0.03	0.00	0.03	8	0.013	0.0050	2.45	0.85	TRY TO INCREASE VELOCITY	ADEQUATE PIPE CAPACITY	19	0.09	47.90	47.81	49.43	49.33	0.43	0.42	Not Enough Cover - Need to Revise Pipe Elevations	Not Enough Cover - Need to Revise Pipe Elevations	8" Underdrain
ELST	29819	29500	Pavement	0.12	0.90	0.11	0.11	5.0	5.0	2.89	0.33	0.00	0.33	8	0.013	0.0050	2.45	0.85	TRY TO INCREASE VELOCITY	ADEQUATE PIPE CAPACITY	319	1.60	47.81	46.21	49.33	48.20	0.42	0.89	Not Enough Cover - Need to Revise Pipe Elevations	Low Cover - See Notes at Bottom	8" Underdrain
ELST	29500	29383	Pavement	0.05	0.90	0.04	0.16	5.0	7.2	2.38	0.38	0.00	0.38	8	0.013	0.0050	2.45	0.85	TRY TO INCREASE VELOCITY	ADEQUATE PIPE CAPACITY	117	0.59	46.21	45.63	48.20	48.52	0.89	1.79	Low Cover - See Notes at Bottom	Low Cover - See Notes at Bottom	8" Underdrain
ELST	29383	29199	Pavement	0.07	0.90	0.06	0.22	5.0	8.0	2.25	0.49	0.00	0.49	8	0.013	0.0050	2.45	0.85	TRY TO INCREASE VELOCITY	ADEQUATE PIPE CAPACITY	184	0.92	45.63	44.71	48.52	47.77	1.79	1.96	Low Cover - See Notes at Bottom	Low Cover - See Notes at Bottom	8" Underdrain
ELST	29199	29150	Pavement	0.02	0.90	0.02	0.24	5.0	9.2	2.08	0.49	0.00	0.49	8	0.013	0.0050	2.45	0.85	TRY TO INCREASE VELOCITY	ADEQUATE PIPE CAPACITY	49	0.24	44.71	44.46	47.77	47.53	1.96	1.97	Low Cover - See Notes at Bottom	Low Cover - See Notes at Bottom	8" Underdrain
ELST	29150	29100	Pavement	0.02	0.90	0.02	0.26	5.0	9.6	2.04	0.52	0.00	0.52	8	0.013	0.0050	2.45	0.85	TRY TO INCREASE VELOCITY	ADEQUATE PIPE CAPACITY	50	0.25	44.46	44.21	47.53	47.61	1.97	2.30	Low Cover - See Notes at Bottom	More than 2 ft of cover	8" Underdrain
ELST	29100	29100	Pavement	0.00	0.90	0.00	0.26	5.0	9.9	2.00	0.52	0.00	0.52	8	0.013	0.0050	2.45	0.85	TRY TO INCREASE VELOCITY	ADEQUATE PIPE CAPACITY	13	0.06	44.21	44.15	47.61	47.34	2.30	2.09	More than 2 ft of cover	More than 2 ft of cover	8" Underdrain
ELST	29100	28925	Pavement	0.06	0.90	0.06	0.31	5.0	10.0	1.99	0.63	0.00	0.63	8	0.013	0.0050	2.45	0.85	TRY TO INCREASE VELOCITY	ADEQUATE PIPE CAPACITY	175	0.88	44.15	43.27	47.34	47.74	2.09	3.37	More than 2 ft of cover	More than 2 ft of cover	8" Underdrain
ELST	28925	28879	Pavement	0.02	1.90	0.04	0.35	5.0	11.2	1.88	0.66	0.00	0.66	8	0.013	0.0050	2.45	0.85	TRY TO INCREASE VELOCITY	ADEQUATE PIPE CAPACITY	46	0.23	43.27	43.04	47.74	47.90	3.37	3.76	More than 2 ft of cover	More than 2 ft of cover	8" Underdrain
ELST	28879	28876	Pavement	0.00	2.90	0.00	0.35	5.0	11.5	1.85	0.66	0.00	0.66	8	0.013	0.0050	2.45	0.85	TRY TO INCREASE VELOCITY	ADEQUATE PIPE CAPACITY	8	0.04	43.04	43.00	47.90	47.40	3.76	3.30	More than 2 ft of cover	More than 2 ft of cover	Underdrain connection to CBF2, inlet to infiltration chamber

See WSDOT Hydraulic Manual 6-5 for explanation of columns. <http://www.wsdot.wa.gov/eesc/design/hydraulics/>

Notes: Column 12 represents inflow from a storm sewer line, branch, an offsite source that flows into the trunk line being analyzed. The conservative assumption is that the flow enters the storm sewer run at the upstream end of the run being analyzed.

For pipe cover calculation, Pipe cover = (Ground or Rim Elevation - Pipe invert elevation) - (pavement thickness) - (top of pipe thickness) - (pipe diameter). The pipe thickness is based on the pipe diameter per WSDOT Manual Concrete for Shallow Pipe Cover Installations Fill Height Table 8-11.2. Please specify the largest pipe thickness of the storm sewer run being analyzed.

The spreadsheet will only calculate one storm sewer line at a time. Please copy the "Blank Template" and use this for calculating new storm sewer lines. If analyzing complicated stormsewer system with multiple lateral lines to the trunk line, it is recommended that Stormshed be used to model the conveyance system. Please contact your region Hydraulic Contact.

**WARNING: START YOUR STORMSEWER RUN ON ROW 12. DO NOT SKIP ANY ROWS IN BETWEEN. USE ONE SHEET PER STORMSEWER RUN**

Please report any problems to the WSDOT HQ Hydraulics Office.



**STORM SEWER DESIGN (English Units)**

This spreadsheet accomplishes a storm sewer design using the rational method. Enter the data in the non-shaded areas only. Please use one spreadsheet per stormsewer run.

Project Name: EAST LAKE SAMMAMISH TRAIL - SOUTH SAMMAMISH SEGMENT B

Designed By: CAB, 6/6/2016  
Project Office: N/A

m = 6.89    n = 0.539    Design Storm Event = 25    Pavement thickness (ft) = 0.33333    Pipe Thickness (inches) = 1.25

Location		Discharge													Drain Design										Drain Profile				Remarks					
Drain Located On	From Sta.	To Sta.	Source of Drainage	Drainage Area A (acre)	Runoff Coeff. C	CA (acre)	Sum (acre)	Tc Across Area (minutes)	Total Tc = Col. 8a + Tc across pipe length (minutes)	Rainfall Intensity (in/hr)	Runoff (cfs)	Contrib. Inflow (cfs)	Total Flow (cfs)	Pipe Dia. (in)	Manning roughness coefficient "n"	Pipe Slope (ft/ft)	Velocity Of Flow (ft/s)	Pipe Capacity (cfs)	Pipe Velocity Check (Desirable Minimum 3 ft/sec; Desirable Maximum 10 ft/sec for Column 16)	Pipe Capacity Check (Column 13 vs. Column 17)	Pipe Length*** (ft)	Elevation Change (ft)	Upstr. Invert Elev. (ft)	Downstr. Invert Elev. (ft)	Upstr. Ground Elev. (ft)	Downstr. Ground Elev. (ft)	Upstr. Pipe Cover (ft)	Downstr. Pipe Cover (ft)	Upstr. Pipe Cover Check (ft)	Downstr. Pipe Cover Check (ft)	Remarks			
Driveway #2 Private Prop.	29882	29882 RT	Pavement	0.15	0.90	0.13	0.13	5.0	5.0	2.89	0.38	0.00	0.38	8	0.013	0.0300	5.99	2.09	VELOCITY OK	ADEQUATE PIPE CAPACITY	6	0.18	47.51	47.33	49.73	49.54	1.12	1.11	1.11	0.79	1.11	0.79	Low Cover - See Notes at Bottom Low Cover - See Notes at Bottom	New CB#3 at private driveway, connect to existing CB in trail. Existing storm pipe flows west to private property, pipe end not found, so slope assumed at 2%

See WSDOT Hydraulic Manual 6-5 for explanation of columns. <http://www.wsdot.wa.gov/eesc/design/hydraulics/>

Notes: Column 12 represents inflow from a storm sewer line, branch, an offsite source that flows into the trunk line being analyzed. The conservative assumption is that the flow enters the storm sewer run at the upstream end of the run being analyzed.

For pipe cover calculation, Pipe cover = (Ground or Rim Elevation - Pipe invert elevation) - (pavement thickness) - (top of pipe thickness) - (pipe diameter). The pipe thickness is based on the pipe diameter per WSDOT Manual Concrete for Shallow Pipe Cover Installations Fill Height Table 8-11.2. Please specify the largest pipe thickness of the storm sewer run being analyzed.

The spreadsheet will only calculate one storm sewer line at a time. Please copy the "Blank Template" and use this for calculating new storm sewer lines. If analyzing complicated stormsewer system with multiple lateral lines to the trunk line, it is recommended that Stormshed be used to model the conveyance system. Please contact your region Hydraulic Contact.

**WARNING: START YOUR STORMSEWER RUN ON ROW 12. DO NOT SKIP ANY ROWS IN BETWEEN. USE ONE SHEET PER STORMSEWER RUN**

Please report any problems to the WSDOT HQ Hydraulics Office.

**STORM SEWER DESIGN (English Units)**

This spreadsheet accomplishes a storm sewer design using the rational method. Enter the data in the non-shaded areas only. Please use one spreadsheet per stormsewer run.

Project Name: **EAST LAKE SAMMAMISH TRAIL - SOUTH SAMMAMISH SEGMENT B**

Designed By: **CAB, 6/6/2016**  
Project Office: **N/A**

m = **6.89**      n = **0.539**      Design Storm Event = **25**      Pavement thickness (ft) = **0.33333**      Pipe Thickness (inches) = **1.25**

Location		Discharge													Drain Design										Drain Profile				Remarks		
Drain Located On	From Sta.	To Sta.	Source of Drainage	Drainage Area A (acre)	Runoff Coeff. C	CA (acre)	Sum (acre)	Tc Across Area (minutes)	Total Tc = Col. 8a + Tc across pipe length (minutes)	Rainfall Intensity (in/hr)	Runoff (cfs)	Contrib. Inflow (cfs)	Total Flow (cfs)	Pipe Dia. (in)	Manning roughness coefficient "n"	Pipe Slope (ft/ft)	Velocity Of Flow (ft/s)	Pipe Capacity (cfs)	Pipe Velocity Check (Desirable Minimum 3 ft/sec; Desirable Maximum 10 ft/sec for Column 16)	Pipe Capacity Check (Column 13 vs. Column 17)	Pipe Length*** (ft)	Elevation Change (ft)	Upstr. Invert Elev. (ft)	Downstr. Invert Elev. (ft)	Upstr. Ground Elev. (ft)	Downstr. Ground Elev. (ft)	Upstr. Pipe Cover (ft)	Downstr. Pipe Cover (ft)	Upstr. Pipe Cover Check (ft)	Downstr. Pipe Cover Check (ft)	Remarks
1	2	3	4	5	6	7	8	8a	9	10	11	12	13	14	14a	15	16	17	17a	17b	18	19	20	21	22	23	24	25	26	27	28
ELST	32035	32012	Pavement	0.01	0.90	0.01	0.01	5.0	5.0	2.89	0.02	0.00	0.02	8	0.013	0.0100	3.46	1.21	VELOCITY OK	ADEQUATE PIPE CAPACITY	18	0.18	47.90	47.72	49.68	49.24	0.68	0.42	Low Cover - See Notes at Bottom	Not Enough Cover - Need to Revise Pipe Elevations	8" Underdrain
ELST	32012	31731	Pavement	0.12	0.90	0.11	0.12	5.0	5.0	2.89	0.35	0.00	0.35	8	0.013	0.0100	3.46	1.21	VELOCITY OK	ADEQUATE PIPE CAPACITY	281	2.81	47.72	44.91	49.24	48.06	0.42	2.05	Not Enough Cover - Need to Revise Pipe Elevations	More than 2 ft of cover	8" Underdrain
ELST	31731	31731	Pavement	0.00	0.90	0.00	0.12	5.0	6.4	2.54	0.35	0.00	0.35	8	0.013	0.0100	3.46	1.21	VELOCITY OK	ADEQUATE PIPE CAPACITY	14	0.14	44.91	44.77	48.06	47.90	2.05	2.03	More than 2 ft of cover	More than 2 ft of cover	8" Underdrain
ELST	31731	31485	Pavement	0.11	0.90	0.10	0.22	5.0	6.4	2.53	0.55	0.00	0.55	8	0.013	0.0100	3.46	1.21	VELOCITY OK	ADEQUATE PIPE CAPACITY	246	2.46	44.77	42.31	47.90	48.12	2.03	4.71	More than 2 ft of cover	More than 2 ft of cover	8" Underdrain
ELST	31485	31463	Pavement	0.01	0.90	0.01	0.23	5.0	7.6	2.31	0.52	0.00	0.52	8	0.013	0.0100	3.46	1.21	VELOCITY OK	ADEQUATE PIPE CAPACITY	22	0.22	42.31	42.09	48.12	48.29	4.71	5.10	More than 2 ft of cover	More than 2 ft of cover	8" Underdrain
ELST	31463	31445	Pavement	0.01	0.90	0.01	0.23	5.0	7.7	2.29	0.54	0.00	0.54	8	0.013	0.0100	3.46	1.21	VELOCITY OK	ADEQUATE PIPE CAPACITY	18	0.18	42.09	41.91	48.29	48.47	5.10	5.46	More than 2 ft of cover	More than 2 ft of cover	8" Underdrain
ELST	31445	31445	N/A	0.00	0.90	0.00	0.23	5.0	7.8	2.28	0.54	0.00	0.54	12	0.013	0.1157	15.42	12.10	TRY TO REDUCE VELOCITY	ADEQUATE PIPE CAPACITY	23	2.66	38.50	35.84	48.47	37.94	8.53	0.66	More than 2 ft of cover	Low Cover - See Notes at Bottom	New 12" SD Connection to Existing SDMH
Private Prop.	31445	31445	N/A	0.00	0.90	0.00	0.23	5.0	7.8	2.27	0.54	0.00	0.54	12	0.013	0.0500	10.14	7.96	TRY TO REDUCE VELOCITY	ADEQUATE PIPE CAPACITY	70	3.50	35.84	32.34	37.94	33.00	0.66	-0.78	Low Cover - See Notes at Bottom	Not Enough Cover - Need to Revise Pipe Elevations	Existing 12" SD Pipe, Direct Discharge to Lake Sammamish

See WSDOT Hydraulic Manual 6-5 for explanation of columns. <http://www.wsdot.wa.gov/eesc/design/hydraulics/>

Notes: Column 12 represents inflow from a storm sewer line, branch, an offsite source that flows into the trunk line being analyzed. The conservative assumption is that the flow enters the storm sewer run at the upstream end of the run being analyzed.

For pipe cover calculation, Pipe cover = (Ground or Rim Elevation - Pipe invert elevation) - (pavement thickness) - (top of pipe thickness) - (pipe diameter). The pipe thickness is based on the pipe diameter per WSDOT Manual Concrete for Shallow Pipe Cover Installations Fill Height Table 8-11.2. Please specify the largest pipe thickness of the storm sewer run being analyzed.

The spreadsheet will only calculate one storm sewer line at a time. Please copy the "Blank Template" and use this for calculating new storm sewer lines. If analyzing complicated stormsewer system with multiple lateral lines to the trunk line, it is recommended that Stormshed be used to model the conveyance system. Please contact your region Hydraulic Contact.

**WARNING: START YOUR STORMSEWER RUN ON ROW 12. DO NOT SKIP ANY ROWS IN BETWEEN. USE ONE SHEET PER STORMSEWER RUN**

Please report any problems to the WSDOT HQ Hydraulics Office.

**STORM SEWER DESIGN (English Units)**

This spreadsheet accomplishes a storm sewer design using the rational method. Enter the data in the **non-shaded areas only**. Please use one spreadsheet per stormsewer run.

Project Name: **EAST LAKE SAMMAMISH TRAIL - SOUTH SAMMAMISH SEGMENT B**

Designed By: **CAB, 10/7/2016**  
Project Office: **N/A**

m = **6.89**    n = **0.539**    Design Storm Event = **25**    Pavement thickness (ft) = **0.33333**    Pipe Thickness (inches) = **1.25**

Location		Discharge													Drain Design										Drain Profile				Remarks		
Drain Located On	From Sta.	To Sta.	Source of Drainage	Drainage Area A (acre)	Runoff Coeff. C	CA (acre)	Sum (acre)	Tc Across Area (minutes)	Total Tc = Col. 8a + Tc across pipe length (minutes)	Rainfall Intensity (in/hr)	Runoff (cfs)	Contrib. Inflow (cfs)	Total Flow (cfs)	Pipe Dia. (in)	Manning roughness coefficient "n"	Pipe Slope (ft/ft)	Velocity Of Flow (ft/s)	Pipe Capacity (cfs)	Pipe Velocity Check (Desirable Minimum 3 ft/sec; Desirable Maximum 10 ft/sec for Column 16)	Pipe Capacity Check (Column 13 vs. Column 17)	Pipe Length*** (ft)	Elevation Change (ft)	Upstr. Invert Elev. (ft)	Downstr. Invert Elev. (ft)	Upstr. Ground Elev. (ft)	Downstr. Ground Elev. (ft)	Upstr. Pipe Cover (ft)	Downstr. Pipe Cover (ft)	Upstr. Pipe Cover Check (ft)	Downstr. Pipe Cover Check (ft)	Remarks
1	2	3	4	5	6	7	8	8a	9	10	11	12	13	14	14a	15	16	17	17a	17b	18	19	20	21	22	23	24	25	26	27	28
ELST	32299	32498	Pavement	0.09	0.90	0.08	0.08	5.0	5.0	2.89	0.24	0.00	0.24	12	0.013	0.0050	3.21	2.52	VELOCITY OK	ADEQUATE PIPE CAPACITY	200	1.00	47.68	46.68	50.68	49.44	1.56	1.32	Low Cover - See Notes at Bottom	Low Cover - See Notes at Bottom	12" SD Pipe
ELST	32498	32572	Pavement	0.08	0.90	0.07	0.15	5.0	6.0	2.61	0.40	0.00	0.40	12	0.013	0.0050	3.21	2.52	VELOCITY OK	ADEQUATE PIPE CAPACITY	74	0.37	46.50	46.13	49.44	49.45	1.50	1.88	Low Cover - See Notes at Bottom	Low Cover - See Notes at Bottom	12" SD Pipe
ELST	32572	32734	Pavement	0.03	0.90	0.03	0.18	5.0	6.4	2.53	0.45	0.00	0.45	12	0.013	0.0100	4.54	3.56	VELOCITY OK	ADEQUATE PIPE CAPACITY	161	1.61	46.00	44.39	49.45	47.54	2.01	1.71	More than 2 ft of cover	Low Cover - See Notes at Bottom	12" SD Pipe
ELST	32734	32867	Pavement	0.06	0.90	0.06	0.23	5.0	7.0	2.41	0.57	0.00	0.57	12	0.013	0.0100	4.54	3.56	VELOCITY OK	ADEQUATE PIPE CAPACITY	130	1.30	44.30	43.00	47.54	48.12	1.80	3.68	Low Cover - See Notes at Bottom	More than 2 ft of cover	12" SD Pipe
ELST	32867	32864 LT	Pavement	0.00	0.90	0.00	0.23	5.0	7.5	2.33	0.57	0.57	1.14	12	0.013	0.0148	5.52	4.33	VELOCITY OK	ADEQUATE PIPE CAPACITY	29	0.43	35.24	34.81	47.61	36.00	10.83	-0.25	More than 2 ft of cover	Not Enough Cover - Need to Revise Pipe Elevations	New 12" SD Pipe Outfall: Direct Discharge to Lake Sammamish, Contrib. Inflow from 8-inch underdrain pipe coming from north

See WSDOT Hydraulic Manual 6-5 for explanation of columns. <http://www.wsdot.wa.gov/eesc/design/hydraulics/>

Notes: Column 12 represents inflow from a storm sewer line, branch, an offsite source that flows into the trunk line being analyzed. The conservative assumption is that the flow enters the storm sewer run at the upstream end of the run being analyzed.

For pipe cover calculation, Pipe cover = (Ground or Rim Elevation - Pipe invert elevation) - (pavement thickness) - (top of pipe thickness) - (pipe diameter). The pipe thickness is based on the pipe diameter per WSDOT Manual Concrete for Shallow Pipe Cover Installations Fill Height Table 8-11.2. Please specify the largest pipe thickness of the storm sewer run being analyzed.

The spreadsheet will only calculate one storm sewer line at a time. Please copy the "Blank Template" and use this for calculating new storm sewer lines. If analyzing complicated stormsewer system with multiple lateral lines to the trunk line, it is recommended that Stormshed be used to model the conveyance system. Please contact your region Hydraulic Contact.

**WARNING: START YOUR STORMSEWER RUN ON ROW 12. DO NOT SKIP ANY ROWS IN BETWEEN. USE ONE SHEET PER STORMSEWER RUN**

Please report any problems to the WSDOT HQ Hydraulics Office.

**STORM SEWER DESIGN (English Units)**

This spreadsheet accomplishes a storm sewer design using the rational method. Enter the data in the **non-shaded areas only**. Please use one spreadsheet per stormsewer run.

Project Name: **EAST LAKE SAMMAMISH TRAIL - SOUTH SAMMAMISH SEGMENT B**

Designed By: **CAB, 10/7/2016**  
Project Office: **N/A**

m = **6.89**    n = **0.539**    Design Storm Event = **25**    Pavement thickness (ft) = **0.33333**    Pipe Thickness (inches) = **1.25**

Location			Discharge													Drain Design										Drain Profile				Remarks	
Drain Located On	From Sta.	To Sta.	Source of Drainage	Drainage Area A (acre)	Runoff Coeff. C	CA (acre)	Sum (acre)	Tc Across Area (minutes)	Total Tc = Col. 8a + Tc across pipe length (minutes)	Rainfall Intensity (in/hr)	Runoff (cfs)	Contrib. Inflow (cfs)	Total Flow (cfs)	Pipe Dia. (in)	Manning roughness coefficient "n"	Pipe Slope (ft/ft)	Velocity Of Flow (ft/s)	Pipe Capacity (cfs)	Pipe Velocity Check (Desirable Minimum 3 ft/sec; Desirable Maximum 10 ft/sec for Column 16)	Pipe Capacity Check (Column 13 vs. Column 17)	Pipe Length*** (ft)	Elevation Change (ft)	Upstr. Invert Elev. (ft)	Downstr. Invert Elev. (ft)	Upstr. Ground Elev. (ft)	Downstr. Ground Elev. (ft)	Upstr. Pipe Cover (ft)	Downstr. Pipe Cover (ft)	Upstr. Pipe Cover Check (ft)	Downstr. Pipe Cover Check (ft)	Remarks
1	2	3	4	5	6	7	8	8a	9	10	11	12	13	14	14a	15	16	17	17a	17b	18	19	20	21	22	23	24	25	26	27	28
ELST	33389	33365	Pavement	0.01	0.90	0.01	0.01	5.0	5.0	2.89	0.02	0.00	0.02	8	0.013	0.0100	3.46	1.21	VELOCITY OK	ADEQUATE PIPE CAPACITY	24	0.24	45.83	45.59	47.58	47.56	0.65	0.87	Low Cover - See Notes at Bottom	Low Cover - See Notes at Bottom	
ELST	33365	32867	Pavement	0.21	0.90	0.19	0.20	5.0	5.0	2.89	0.57	0.00	0.57	8	0.013	0.0100	3.46	1.21	VELOCITY OK	ADEQUATE PIPE CAPACITY	498	4.99	45.59	40.60	47.56	47.73	0.87	6.03	Low Cover - See Notes at Bottom	More than 2 ft of cover	Connection to New CB Type 2; Direct Discharge to Lake Sammamish

See WSDOT Hydraulic Manual 6-5 for explanation of columns. <http://www.wsdot.wa.gov/eesc/design/hydraulics/>

Notes: Column 12 represents inflow from a storm sewer line, branch, an offsite source that flows into the trunk line being analyzed. The conservative assumption is that the flow enters the storm sewer run at the upstream end of the run being analyzed.

For pipe cover calculation, Pipe cover = (Ground or Rim Elevation - Pipe invert elevation) - (pavement thickness) - (top of pipe thickness) - (pipe diameter). The pipe thickness is based on the pipe diameter per WSDOT Manual Concrete for Shallow Pipe Cover Installations Fill Height Table 8-11.2. Please specify the largest pipe thickness of the storm sewer run being analyzed.

The spreadsheet will only calculate one storm sewer line at a time. Please copy the "Blank Template" and use this for calculating new storm sewer lines. If analyzing complicated stormsewer system with multiple lateral lines to the trunk line, it is recommended that Stormshed be used to model the conveyance system. Please contact your region Hydraulic Contact.

**WARNING: START YOUR STORMSEWER RUN ON ROW 12. DO NOT SKIP ANY ROWS IN BETWEEN. USE ONE SHEET PER STORMSEWER RUN**

Please report any problems to the WSDOT HQ Hydraulics Office.

**STORM SEWER DESIGN (English Units)**

This spreadsheet accomplishes a storm sewer design using the rational method. Enter the data in the non-shaded areas only. Please use one spreadsheet per stormsewer run.

Project Name: **EAST LAKE SAMMAMISH TRAIL - SOUTH SAMMAMISH SEGMENT B**

Designed By: **CAB, 6/6/2016**  
Project Office: **N/A**

m = **6.89**    n = **0.539**    Design Storm Event = **25**    Pavement thickness (ft) = **0.33333**    Pipe Thickness (inches) = **1.25**

Location			Discharge / Drain Design														Drain Profile						Remarks								
Drain Located On	From Sta.	To Sta.	Source of Drainage	Drainage Area A (acre)	Runoff Coeff. C	CA (acre)	Sum (acre)	Tc Across Area (minutes)	Total Tc = Col. 8a + Tc across pipe length (minutes)	Rainfall Intensity (in/hr)	Runoff (cfs)	Contrib. Inflow (cfs)	Total Flow (cfs)	Pipe Dia. (in)	Manning roughness coefficient "n"	Pipe Slope (ft/ft)	Velocity Of Flow (ft/s)	Pipe Capacity (cfs)	Pipe Velocity Check (Desirable Minimum 3 ft/sec; Desirable Maximum 10 ft/sec for Column 16)	Pipe Capacity Check (Column 13 vs. Column 17)	Pipe Length*** (ft)	Elevation Change (ft)	Upstr. Invert Elev. (ft)	Downstr. Invert Elev. (ft)	Upstr. Ground Elev. (ft)	Downstr. Ground Elev. (ft)	Upstr. Pipe Cover (ft)	Downstr. Pipe Cover (ft)	Upstr. Pipe Cover Check (ft)	Downstr. Pipe Cover Check (ft)	Remarks
ELST	34750	34225	Pavement	0.22	0.90	0.20	0.20	5.0	5.0	2.89	0.57	0.00	0.57	8	0.013	0.0050	2.45	0.85	TRY TO INCREASE VELOCITY	ADEQUATE PIPE CAPACITY	525	2.63	43.94	41.32	45.69	45.43	0.65	3.01	Low Cover - See Notes at Bottom	More than 2 ft of cover	8" Underdrain
ELST	34225	34200	Pavement	0.01	0.90	0.01	0.21	5.0	8.6	2.16	0.45	0.00	0.45	8	0.013	0.0050	2.45	0.85	TRY TO INCREASE VELOCITY	ADEQUATE PIPE CAPACITY	19	0.09	38.00	37.91	45.43	45.47	6.33	6.46	More than 2 ft of cover	More than 2 ft of cover	8" Underdrain, Connection to New CB Type 2
ELST	34200	34200	Pavement	0.00	0.90	0.00	0.21	5.0	8.7	2.15	0.45	0.00	0.45	12	0.013	0.0306	7.93	6.22	VELOCITY OK	ADEQUATE PIPE CAPACITY	18	0.55	37.05	36.50	45.47	37.00	6.98	-0.94	More than 2 ft of cover	Not Enough Cover - Need to Revise Pipe Elevations	New 12-inch SD Outfall, Direct Discharge to Lake Sammamish

See WSDOT Hydraulic Manual 6-5 for explanation of columns. <http://www.wsdot.wa.gov/eesc/design/hydraulics/>

Notes: Column 12 represents inflow from a storm sewer line, branch, an offsite source that flows into the trunk line being analyzed. The conservative assumption is that the flow enters the storm sewer run at the upstream end of the run being analyzed.

For pipe cover calculation, Pipe cover = (Ground or Rim Elevation - Pipe invert elevation) - (pavement thickness) - (top of pipe thickness) - (pipe diameter). The pipe thickness is based on the pipe diameter per WSDOT Manual Concrete for Shallow Pipe Cover Installations Fill Height Table 8-11.2. Please specify the largest pipe thickness of the storm sewer run being analyzed.

The spreadsheet will only calculate one storm sewer line at a time. Please copy the "Blank Template" and use this for calculating new storm sewer lines. If analyzing complicated stormsewer system with multiple lateral lines to the trunk line, it is recommended that Stormshed be used to model the conveyance system. Please contact your region Hydraulic Contact.

**WARNING: START YOUR STORMSEWER RUN ON ROW 12. DO NOT SKIP ANY ROWS IN BETWEEN. USE ONE SHEET PER STORMSEWER RUN**

Please report any problems to the WSDOT HQ Hydraulics Office.



**STORM SEWER DESIGN (English Units)**

This spreadsheet accomplishes a storm sewer design using the rational method. Enter the data in the non-shaded areas only. Please use one spreadsheet per stormsewer run.

Project Name: EAST LAKE SAMMAMISH TRAIL - SOUTH SAMMAMISH SEGMENT B

Designed By: CAB, 6/6/2016  
Project Office: N/A

m = 6.89      n = 0.539      Design Storm Event = 25      Pavement thickness (ft) = 0.33333      Pipe Thickness (inches) = 1.25

Location			Discharge													Drain Profile										Remarks					
Drain Located On	From Sta.	To Sta.	Source of Drainage	Drainage Area A (acre)	Runoff Coeff. C	CA (acre)	Sum (acre)	Tc Across Area (minutes)	Total Tc = Col. 8a + Tc across pipe length (minutes)	Rainfall Intensity (in/hr)	Runoff (cfs)	Contrib. Inflow (cfs)	Total Flow (cfs)	Pipe Dia. (in)	Manning roughness coefficient "n"	Pipe Slope (ft/ft)	Velocity Of Flow (ft/s)	Pipe Capacity (cfs)	Pipe Velocity Check (Desirable Minimum 3 ft/sec; Desirable Maximum 10 ft/sec for Column 16)	Pipe Capacity Check (Column 13 vs. Column 17)	Pipe Length*** (ft)	Elevation Change (ft)	Upstr. Invert Elev. (ft)	Downstr. Invert Elev. (ft)	Upstr. Ground Elev. (ft)	Downstr. Ground Elev. (ft)	Upstr. Pipe Cover (ft)	Downstr. Pipe Cover (ft)	Upstr. Pipe Cover Check (ft)	Downstr. Pipe Cover Check (ft)	Remarks
1	2	3	4	5	6	7	8	8a	9	10	11	12	13	14	14a	15	16	17	17a	17b	18	19	20	21	22	23	24	25	26	27	28
ELST	35126	35135	Pavement	0.00	0.90	0.00	0.00	5.0	5.0	2.89	0.01	0.00	0.01	6	0.013	0.0072	2.42	0.48	TRY TO INCREASE VELOCITY	ADEQUATE PIPE CAPACITY	9	0.06	44.84	44.78	46.34	46.25	0.56	0.54	Low Cover - See Notes at Bottom	Low Cover - See Notes at Bottom	6" Underdrain
ELST	35135	35200	Pavement	0.03	0.90	0.03	0.03	5.0	5.0	2.89	0.09	0.00	0.09	6	0.013	0.0072	2.42	0.48	TRY TO INCREASE VELOCITY	ADEQUATE PIPE CAPACITY	65	0.47	44.78	44.31	46.25	46.25	0.54	1.01	Low Cover - See Notes at Bottom	Low Cover - See Notes at Bottom	6" Underdrain
ELST	35200	35250	Pavement	0.02	0.90	0.02	0.05	5.0	5.4	2.76	0.14	0.00	0.14	6	0.013	0.0072	2.42	0.48	TRY TO INCREASE VELOCITY	ADEQUATE PIPE CAPACITY	50	0.36	44.31	43.95	46.25	46.42	1.01	1.54	Low Cover - See Notes at Bottom	Low Cover - See Notes at Bottom	6" Underdrain, Connection to New CB Type 1 that connects to existing 12" Diam Culvert, Discharge west to Lake Sammamish

See WSDOT Hydraulic Manual 6-5 for explanation of columns. <http://www.wsdot.wa.gov/eesc/design/hydraulics/>

Notes: Column 12 represents inflow from a storm sewer line, branch, an offsite source that flows into the trunk line being analyzed. The conservative assumption is that the flow enters the storm sewer run at the upstream end of the run being analyzed.

For pipe cover calculation, Pipe cover = (Ground or Rim Elevation - Pipe invert elevation) - (pavement thickness) - (top of pipe thickness) - (pipe diameter). The pipe thickness is based on the pipe diameter per WSDOT Manual Concrete for Shallow Pipe Cover Installations Fill Height Table 8-11.2. Please specify the largest pipe thickness of the storm sewer run being analyzed.

The spreadsheet will only calculate one storm sewer line at a time. Please copy the "Blank Template" and use this for calculating new storm sewer lines. If analyzing complicated stormsewer system with multiple lateral lines to the trunk line, it is recommended that Stormshed be used to model the conveyance system. Please contact your region Hydraulic Contact.

**WARNING: START YOUR STORMSEWER RUN ON ROW 12. DO NOT SKIP ANY ROWS IN BETWEEN. USE ONE SHEET PER STORMSEWER RUN**

Please report any problems to the WSDOT HQ Hydraulics Office.

**STORM SEWER DESIGN (English Units)**

This spreadsheet accomplishes a storm sewer design using the rational method. Enter the data in the non-shaded areas only. Please use one spreadsheet per stormsewer run.

Project Name: **EAST LAKE SAMMAMISH TRAIL - SOUTH SAMMAMISH SEGMENT B**

Designed By: **CAB, 6/6/2016**  
Project Office: **N/A**

m = **6.89**    n = **0.539**    Design Storm Event = **25**    Pavement thickness (ft) = **0.33333**    Pipe Thickness (inches) = **1.25**

Location		Discharge													Drain Design										Drain Profile				Remarks		
Drain Located On	From Sta.	To Sta.	Source of Drainage	Drainage Area A (acre)	Runoff Coeff. C	CA (acre)	Sum (acre)	Tc Across Area (minutes)	Total Tc = Col. 8a + Tc across pipe length (minutes)	Rainfall Intensity (in/hr)	Runoff (cfs)	Contrib. Inflow (cfs)	Total Flow (cfs)	Pipe Dia. (in)	Manning roughness coefficient "n"	Pipe Slope (ft/ft)	Velocity Of Flow (ft/s)	Pipe Capacity (cfs)	Pipe Velocity Check (Desirable Minimum 3 ft/sec; Desirable Maximum 10 ft/sec for Column 16)	Pipe Capacity Check (Column 13 vs. Column 17)	Pipe Length*** (ft)	Elevation Change (ft)	Upstr. Invert Elev. (ft)	Downstr. Invert Elev. (ft)	Upstr. Ground Elev. (ft)	Downstr. Ground Elev. (ft)	Upstr. Pipe Cover (ft)	Downstr. Pipe Cover (ft)	Upstr. Pipe Cover Check (ft)	Downstr. Pipe Cover Check (ft)	Remarks
1	2	3	4	5	6	7	8	8a	9	10	11	12	13	14	14a	15	16	17	17a	17b	18	19	20	21	22	23	24	25	26	27	28
ELST	35323	35279	Pavement	0.02	0.90	0.02	0.02	5.0	5.0	2.89	0.05	0.00	0.05	6	0.013	0.0138	3.36	0.66	VELOCITY OK	ADEQUATE PIPE CAPACITY	44	0.61	44.90	44.29	46.68	46.42	0.84	1.19	Low Cover - See Notes at Bottom	Low Cover - See Notes at Bottom	6" Underdrain
ELST	35279	35272	Pavement	0.00	0.90	0.00	0.02	5.0	5.2	2.83	0.05	0.00	0.05	6	0.013	0.0138	3.36	0.66	VELOCITY OK	ADEQUATE PIPE CAPACITY	5	0.07	44.29	44.22	46.42	46.48	1.19	1.32	Low Cover - See Notes at Bottom	Low Cover - See Notes at Bottom	6" Underdrain
ELST	35272	35252	Pavement	0.01	0.90	0.01	0.03	5.0	5.2	2.82	0.08	0.00	0.08	6	0.013	0.0137	3.34	0.66	VELOCITY OK	ADEQUATE PIPE CAPACITY	20	0.27	44.22	43.95	46.48	46.42	1.32	1.53	Low Cover - See Notes at Bottom	Low Cover - See Notes at Bottom	6" Underdrain, Connection to New CB Type 1 that connects to
ELST	35252	35252	Pavement	0.00	0.90	0.00	0.03	5.0	5.3	2.79	0.08	0.14	0.21	12	0.013	0.0456	8.70	7.62	VELOCITY OK	ADEQUATE PIPE CAPACITY	19	0.87	43.45	42.58	46.42	44.25	1.53	0.23	Low Cover - See Notes at Bottom	Not Enough Cover - Need to Revise Pipe Elevations	Existing 12" Diam Culvert, Discharge west to Lake Sammamish

See WSDOT Hydraulic Manual 6-5 for explanation of columns. <http://www.wsdot.wa.gov/eesc/design/hydraulics/>

Notes: Column 12 represents inflow from a storm sewer line, branch, an offsite source that flows into the trunk line being analyzed. The conservative assumption is that the flow enters the storm sewer run at the upstream end of the run being analyzed.

For pipe cover calculation, Pipe cover = (Ground or Rim Elevation - Pipe invert elevation) - (pavement thickness) - (top of pipe thickness) - (pipe diameter). The pipe thickness is based on the pipe diameter per WSDOT Manual Concrete for Shallow Pipe Cover Installations Fill Height Table 8-11.2. Please specify the largest pipe thickness of the storm sewer run being analyzed.

The spreadsheet will only calculate one storm sewer line at a time. Please copy the "Blank Template" and use this for calculating new storm sewer lines. If analyzing complicated stormsewer system with multiple lateral lines to the trunk line, it is recommended that Stormshed be used to model the conveyance system. Please contact your region Hydraulic Contact.

**WARNING: START YOUR STORMSEWER RUN ON ROW 12. DO NOT SKIP ANY ROWS IN BETWEEN. USE ONE SHEET PER STORMSEWER RUN**

Please report any problems to the WSDOT HQ Hydraulics Office.



**STORM SEWER DESIGN (English Units)**

This spreadsheet accomplishes a storm sewer design using the rational method. Enter the data in the **non-shaded areas only**. Please use one spreadsheet per stormsewer run.

Project Name: **EAST LAKE SAMMAMISH TRAIL - SOUTH SAMMAMISH SEGMENT B**

Designed By: **CAB, 6/6/2016**  
Project Office: **N/A**

m = **5.62**    n = **0.53**    Design Storm Event = **10**    Pavement thickness (ft) = **0.33333**    Pipe Thickness (inches) = **1.25**

Location			Discharge / Drain Design													Drain Profile								Remarks							
Drain Located On	From Sta.	To Sta.	Source of Drainage	Drainage Area A (acre)	Runoff Coeff. C	CA (acre)	Sum (acre)	Tc Across Area (minutes)	Total Tc = Col. 8a + Tc across pipe length (minutes)	Rainfall Intensity (in/hr)	Runoff (cfs)	Contrib. Inflow (cfs)	Total Flow (cfs)	Pipe Dia. (in)	Manning roughness coefficient "n"	Pipe Slope (ft/ft)	Velocity Of Flow (ft/s)	Pipe Capacity (cfs)	Pipe Velocity Check (Desirable Minimum 3 ft/sec; Desirable Maximum 10 ft/sec for Column 16)	Pipe Capacity Check (Column 13 vs. Column 17)	Pipe Length*** (ft)	Elevation Change (ft)	Upstr. Invert Elev. (ft)	Downstr. Invert Elev. (ft)	Upstr. Ground Elev. (ft)	Downstr. Ground Elev. (ft)	Upstr. Pipe Cover (ft)	Downstr. Pipe Cover (ft)	Upstr. Pipe Cover Check (ft)	Downstr. Pipe Cover Check (ft)	Remarks
1	2	3	4	5	6	7	8	8a	9	10	11	12	13	14	14a	15	16	17	17a	17b	18	19	20	21	22	23	24	25	26	27	28
ELST	35979	36107	Pavement	0.06	0.90	0.05	0.05	5.0	5.0	2.39	0.12	0.00	0.12	12	0.013	0.0417	9.26	7.26	VELOCITY OK	ADEQUATE PIPE CAPACITY	54	2.25	42.75	40.50	47.62	44.72	3.43	2.78	More than 2 ft of cover	More than 2 ft of cover	12" storm pipe
ELST	36107	36216	Pavement	0.02	0.90	0.02	0.07	5.0	5.1	2.37	0.17	0.00	0.17	12	0.013	0.0655	11.60	9.11	TRY TO REDUCE VELOCITY	ADEQUATE PIPE CAPACITY	42	2.75	39.75	37.00	44.72	40.00	3.53	1.56	More than 2 ft of cover	Low Cover - See Notes at Bottom	12" storm pipe
Shore Ln SE	36161	36136	Pavement	0.00	0.90	0.00	0.07	5.0	5.2	2.36	0.17	0.00	0.17	12	0.013	0.0164	5.81	4.56	VELOCITY OK	ADEQUATE PIPE CAPACITY	25	0.41	37.00	36.59	40.00	38.90	1.56	0.87	Low Cover - See Notes at Bottom	Low Cover - See Notes at Bottom	12" storm pipe, New CB connects to existing 4" diam. private pipes
Private Prop.	36136	Lk Samm	Pavement	0.14	0.90	0.12	0.20	5.0	5.0	2.39	0.47	0.00	0.47	4	0.013	0.0219	3.23	0.28	VELOCITY OK	NEED MORE CAPACITY	94	2.06	37.06	35.00	38.90	36.00	1.07	0.23	Low Cover - See Notes at Bottom	Not Enough Cover - Need to Revise Pipe Elevations	4" drain pipe from CB to Lake Sammamish, via private property

See WSDOT Hydraulic Manual 6-5 for explanation of columns. <http://www.wsdot.wa.gov/eesc/design/hydraulics/>

Notes: Column 12 represents inflow from a storm sewer line, branch, an offsite source that flows into the trunk line being analyzed. The conservative assumption is that the flow enters the storm sewer run at the upstream end of the run being analyzed.

For pipe cover calculation, Pipe cover = (Ground or Rim Elevation - Pipe invert elevation) - (pavement thickness) - (top of pipe thickness) - (pipe diameter). The pipe thickness is based on the pipe diameter per WSDOT Manual Concrete for Shallow Pipe Cover Installations Fill Height Table 8-11.2. Please specify the largest pipe thickness of the storm sewer run being analyzed.

The spreadsheet will only calculate one storm sewer line at a time. Please copy the "Blank Template" and use this for calculating new storm sewer lines. If analyzing complicated stormsewer system with multiple lateral lines to the trunk line, it is recommended that Stormshed be used to model the conveyance system. Please contact your region Hydraulic Contact.

**WARNING: START YOUR STORMSEWER RUN ON ROW 12. DO NOT SKIP ANY ROWS IN BETWEEN. USE ONE SHEET PER STORMSEWER RUN**

Please report any problems to the WSDOT HQ Hydraulics Office.

**STORM SEWER DESIGN (English Units)**

This spreadsheet accomplishes a storm sewer design using the rational method. Enter the data in the non-shaded areas only. Please use one spreadsheet per stormsewer run.

Project Name: **EAST LAKE SAMMAMISH TRAIL - SOUTH SAMMAMISH SEGMENT B**

Designed By: **CAB, 6/6/2016**  
Project Office: **N/A**

m = **6.89**    n = **0.539**    Design Storm Event = **25**    Pavement thickness (ft) = **0.33333**    Pipe Thickness (inches) = **1.25**

Location			Discharge / Drain Design														Drain Profile						Remarks								
Drain Located On	From Sta.	To Sta.	Source of Drainage	Drainage Area A (acre)	Runoff Coeff. C	CA (acre)	Sum (acre)	Tc Across Area (minutes)	Total Tc = Col. 8a + Tc across pipe length (minutes)	Rainfall Intensity (in/hr)	Runoff (cfs)	Contrib. Inflow (cfs)	Total Flow (cfs)	Pipe Dia. (in)	Manning roughness coefficient "n"	Pipe Slope (ft/ft)	Velocity Of Flow (ft/s)	Pipe Capacity (cfs)	Pipe Velocity Check (Desirable Minimum 3 ft/sec; Desirable Maximum 10 ft/sec for Column 16)	Pipe Capacity Check (Column 13 vs. Column 17)	Pipe Length*** (ft)	Elevation Change (ft)	Upstr. Invert Elev. (ft)	Downstr. Invert Elev. (ft)	Upstr. Ground Elev. (ft)	Downstr. Ground Elev. (ft)	Upstr. Pipe Cover (ft)	Downstr. Pipe Cover (ft)	Upstr. Pipe Cover Check (ft)	Downstr. Pipe Cover Check (ft)	Remarks
1	2	3	4	5	6	7	8	8a	9	10	11	12	13	14	14a	15	16	17	17a	17b	18	19	20	21	22	23	24	25	26	27	28
ELST	35979	36107	Pavement	0.06	0.90	0.05	0.05	5.0	5.0	2.89	0.15	0.00	0.15	12	0.013	0.0417	9.26	7.26	VELOCITY OK	ADEQUATE PIPE CAPACITY	54	2.25	42.75	40.50	47.62	44.72	3.43	2.78	More than 2 ft of cover	More than 2 ft of cover	12" storm pipe
ELST	36107	36216	Pavement	0.02	0.90	0.02	0.07	5.0	5.1	2.86	0.21	0.00	0.21	12	0.013	0.0655	11.60	9.11	TRY TO REDUCE VELOCITY	ADEQUATE PIPE CAPACITY	42	2.75	39.75	37.00	44.72	40.00	3.53	1.56	More than 2 ft of cover	Low Cover - See Notes at Bottom	12" storm pipe
Shore Ln SE	36161	36136	Pavement	0.00	0.90	0.00	0.07	5.0	5.2	2.85	0.21	0.00	0.21	12	0.013	0.0164	5.81	4.56	VELOCITY OK	ADEQUATE PIPE CAPACITY	25	0.41	37.00	36.59	40.00	38.90	1.56	0.87	Low Cover - See Notes at Bottom	Low Cover - See Notes at Bottom	12" storm pipe, New CB connects to existing 4" diam. private pipes
Private Prop.	36136	Lk Samm	Pavement	0.14	0.90	0.12	0.20	5.0	5.0	2.89	0.56	0.00	0.56	4	0.013	0.0219	3.23	0.28	VELOCITY OK	NEED MORE CAPACITY	94	2.06	37.06	35.00	38.90	36.00	1.07	0.23	Low Cover - See Notes at Bottom	Not Enough Cover - Need to Revise Pipe Elevations	4" drain pipe from CB to Lake Sammamish, via private property

See WSDOT Hydraulic Manual 6-5 for explanation of columns. <http://www.wsdot.wa.gov/eesc/design/hydraulics/>

Notes: Column 12 represents inflow from a storm sewer line, branch, an offsite source that flows into the trunk line being analyzed. The conservative assumption is that the flow enters the storm sewer run at the upstream end of the run being analyzed.

For pipe cover calculation, Pipe cover = (Ground or Rim Elevation - Pipe invert elevation) - (pavement thickness) - (top of pipe thickness) - (pipe diameter). The pipe thickness is based on the pipe diameter per WSDOT Manual Concrete for Shallow Pipe Cover Installations Fill Height Table 8-11.2. Please specify the largest pipe thickness of the storm sewer run being analyzed.

The spreadsheet will only calculate one storm sewer line at a time. Please copy the "Blank Template" and use this for calculating new storm sewer lines. If analyzing complicated stormsewer system with multiple lateral lines to the trunk line, it is recommended that Stormshed be used to model the conveyance system. Please contact your region Hydraulic Contact.

**WARNING: START YOUR STORMSEWER RUN ON ROW 12. DO NOT SKIP ANY ROWS IN BETWEEN. USE ONE SHEET PER STORMSEWER RUN**

Please report any problems to the WSDOT HQ Hydraulics Office.



**STORM SEWER DESIGN (English Units)**

This spreadsheet accomplishes a storm sewer design using the rational method. Enter the data in the **non-shaded areas only**. Please use one spreadsheet per stormsewer run.

Project Name: **EAST LAKE SAMMAMISH TRAIL - SOUTH SAMMAMISH SEGMENT B**

Designed By: **CAB, 6/6/2016**  
Project Office: **N/A**

m = **6.89**    n = **0.539**    Design Storm Event = **25**    Pavement thickness (ft) = **0.33333**    Pipe Thickness (inches) = **1.25**

Location		Discharge													Drain Design										Drain Profile				Remarks			
Drain Located On	From Sta.	To Sta.	Source of Drainage	Drainage Area A (acre)	Runoff Coeff. C	CA (acre)	Sum (acre)	Tc (min)	Tc across pipe length (minutes)	Total Tc = Col. 8a + Tc across pipe length (minutes)	Rainfall Intensity (in/hr)	Runoff (cfs)	Contrib. Inflow (cfs)	Total Flow (cfs)	Pipe Dia. (in)	Manning roughness coefficient "n"	Pipe Slope (ft/ft)	Velocity Of Flow (ft/s)	Pipe Capacity (cfs)	Pipe Velocity Check (Desirable Minimum 3 ft/sec; Desirable Maximum 10 ft/sec for Column 16)	Pipe Capacity Check (Column 13 vs. Column 17)	Pipe Length*** (ft)	Elevation Change (ft)	Upstr. Invert Elev. (ft)	Downstr. Invert Elev. (ft)	Upstr. Ground Elev. (ft)	Downstr. Ground Elev. (ft)	Upstr. Pipe Cover (ft)	Downstr. Pipe Cover (ft)	Upstr. Pipe Cover Check (ft)	Downstr. Pipe Cover Check (ft)	Remarks
ELST	36698 RT	36700 LT	Pavement	0.29	0.90	0.26	0.26	5.0	5.0	2.89	0.76	2.50	3.26	12	0.013	0.0300	7.86	8.16	VELOCITY OK	ADEQUATE PIPE CAPACITY	32	0.96	42.56	41.60	43.06	43.63	-0.94	0.59	Not Enough Cover - Need to Revise Pipe Elevations	Low Cover - See Notes at Bottom	Contributing flow is from offsite, east of the project	
Shore Ln SE	36700 LT	36713 LT	Pavement	0.00	0.90	0.00	0.26	5.0	5.1	2.87	0.76	0.00	3.26	12	0.013	0.0789	12.74	10.00	TRY TO REDUCE VELOCITY	ADEQUATE PIPE CAPACITY	19	1.50	41.50	40.00	43.63	42.61	0.69	1.17	Low Cover - See Notes at Bottom	Low Cover - See Notes at Bottom	Connection to existing drainage structure in Shore Lane SE	

See WSDOT Hydraulic Manual 6-5 for explanation of columns. <http://www.wsdot.wa.gov/eesc/design/hydraulics/>

Notes: Column 12 represents inflow from a storm sewer line, branch, an offsite source that flows into the trunk line being analyzed. The conservative assumption is that the flow enters the storm sewer run at the upstream end of the run being analyzed.

For pipe cover calculation, Pipe cover = (Ground or Rim Elevation - Pipe invert elevation) - (pavement thickness) - (top of pipe thickness) - (pipe diameter). The pipe thickness is based on the pipe diameter per WSDOT Manual Concrete for Shallow Pipe Cover Installations Fill Height Table 8-11.2. Please specify the largest pipe thickness of the storm sewer run being analyzed.

The spreadsheet will only calculate one storm sewer line at a time. Please copy the "Blank Template" and use this for calculating new storm sewer lines. If analyzing complicated stormsewer system with multiple lateral lines to the trunk line, it is recommended that Stormshed be used to model the conveyance system. Please contact your region Hydraulic Contact.

**WARNING: START YOUR STORMSEWER RUN ON ROW 12. DO NOT SKIP ANY ROWS IN BETWEEN. USE ONE SHEET PER STORMSEWER RUN**

Please report any problems to the WSDOT HQ Hydraulics Office.

**STORM SEWER DESIGN (English Units)**

This spreadsheet accomplishes a storm sewer design using the rational method. Enter the data in the non-shaded areas only. Please use one spreadsheet per stormsewer run.

Project Name: EAST LAKE SAMMAMISH TRAIL - SOUTH SAMMAMISH SEGMENT B

Designed By: CAB, 10/11/2016  
Project Office: N/A

m = 6.89      n = 0.539      Design Storm Event = 25      Pavement thickness (ft) = 0.33333      Pipe Thickness (inches) = 1.25

Location		Discharge													Drain Design										Drain Profile				Remarks			
Drain Located On	From Sta.	To Sta.	Source of Drainage	Drainage Area A (acre)	Runoff Coeff. C	CA (acre)	Sum (acre)	Tc Across Area (minutes)	Total Tc = Col. 8a + Tc across pipe length (minutes)	Rainfall Intensity (in/hr)	Runoff (cfs)	Contrib. Inflow (cfs)	Total Flow (cfs)	Pipe Dia. (in)	Manning roughness coefficient "n"	Pipe Slope (ft/ft)	Velocity Of Flow (ft/s)	Pipe Capacity (cfs)	Pipe Velocity Check (Desirable Minimum 3 ft/sec; Desirable Maximum 10 ft/sec for Column 16)	Pipe Capacity Check (Column 13 vs. Column 17)	Pipe Length*** (ft)	Elevation Change (ft)	Upstr. Invert Elev. (ft)	Downstr. Invert Elev. (ft)	Upstr. Ground Elev. (ft)	Downstr. Ground Elev. (ft)	Upstr. Pipe Cover (ft)	Downstr. Pipe Cover (ft)	Upstr. Pipe Cover Check (ft)	Downstr. Pipe Cover Check (ft)	Remarks	
1	2	3	4	5	6	7	8	8a	9	10	11	12	13	14	14a	15	16	17	17a	17b	18	19	20	21	22	23	24	25	26	27	28	
ELST	43633	43628	Trail	0.17	0.90	0.16	0.16	5.0	5.0	2.89	0.45	0.00	0.45	12	0.013	0.1431	17.16	13.46	TRY TO REDUCE VELOCITY	ADEQUATE PIPE CAPACITY	48	6.87	45.87	39.00	45.66	43.87	-1.65	3.43	3.46	More than 2 ft of cover	More than 2 ft of cover	Culvert Inlet at Jurisdictional Ditch #16
Shore Ln NE	43628	43569	None	0.00	0.90	0.00	0.16	5.0	5.0	2.88	0.45	0.00	0.45	12	0.013	0.0283	7.63	5.99	VELOCITY OK	ADEQUATE PIPE CAPACITY	60	1.70	38.90	37.20	43.87	42.10	3.53	3.46	More than 2 ft of cover	More than 2 ft of cover		
Shore Ln NE	43569	43556	None	0.00	0.90	0.00	0.16	5.0	5.2	2.84	0.45	0.00	0.45	12	0.013	0.0472	9.85	7.73	VELOCITY OK	ADEQUATE PIPE CAPACITY	116	8.47	37.10	31.63	42.10	34.50	3.56	1.43	More than 2 ft of cover	Low Cover - See Notes at Bottom		
Private Prop.	43556	43553	None	0.00	0.90	0.00	0.16	5.0	5.4	2.78	0.45	0.00	0.45	12	0.013	0.0204	6.47	5.08	VELOCITY OK	ADEQUATE PIPE CAPACITY	26	0.53	31.63	31.10	34.50	31.10	1.43	-1.44	Low Cover - See Notes at Bottom	Not Enough Cover - Need to Revise Pipe Elevations	New 12-inch SD Outfall: Direct Discharge to Lake Sammamish	

See WSDOT Hydraulic Manual 6-5 for explanation of columns. <http://www.wsdot.wa.gov/eesc/design/hydraulics/>

Notes: Column 12 represents inflow from a storm sewer line, branch, an offsite source that flows into the trunk line being analyzed. The conservative assumption is that the flow enters the storm sewer run at the upstream end of the run being analyzed.

For pipe cover calculation, Pipe cover = (Ground or Rim Elevation - Pipe invert elevation) - (pavement thickness) - (top of pipe thickness) - (pipe diameter). The pipe thickness is based on the pipe diameter per WSDOT Manual Concrete for Shallow Pipe Cover Installations Fill Height Table 8-11.2. Please specify the largest pipe thickness of the storm sewer run being analyzed.

The spreadsheet will only calculate one storm sewer line at a time. Please copy the "Blank Template" and use this for calculating new storm sewer lines. If analyzing complicated stormsewer system with multiple lateral lines to the trunk line, it is recommended that Stormshed be used to model the conveyance system. Please contact your region Hydraulic Contact.

**WARNING: START YOUR STORMSEWER RUN ON ROW 12. DO NOT SKIP ANY ROWS IN BETWEEN. USE ONE SHEET PER STORMSEWER RUN**

Please report any problems to the WSDOT HQ Hydraulics Office.

**STORM SEWER DESIGN (English Units)**

This spreadsheet accomplishes a storm sewer design using the rational method. Enter the data in the non-shaded areas only. Please use one spreadsheet per stormsewer run.

Project Name: **EAST LAKE SAMMAMISH TRAIL - SOUTH SAMMAMISH SEGMENT B**

Designed By: **CAB, 10/7/2016**  
Project Office: **N/A**

m = **6.89**    n = **0.539**    Design Storm Event = **25**    Pavement thickness (ft) = **0.33333**    Pipe Thickness (inches) = **1.25**

Location			Discharge													Drain Design										Drain Profile				Remarks	
Drain Located On	From Sta.	To Sta.	Source of Drainage	Drainage Area A (acre)	Runoff Coeff. C	CA (acre)	Sum (acre)	Tc Across Area (minutes)	Total Tc = Col. 8a + Tc across pipe length (minutes)	Rainfall Intensity (in/hr)	Runoff (cfs)	Contrib. Inflow (cfs)	Total Flow (cfs)	Pipe Dia. (in)	Manning roughness coefficient "n"	Pipe Slope (ft/ft)	Velocity Of Flow (ft/s)	Pipe Capacity (cfs)	Pipe Velocity Check (Desirable Minimum 3 ft/sec; Desirable Maximum 10 ft/sec for Column 16)	Pipe Capacity Check (Column 13 vs. Column 17)	Pipe Length*** (ft)	Elevation Change (ft)	Upstr. Invert Elev. (ft)	Downstr. Invert Elev. (ft)	Upstr. Ground Elev. (ft)	Downstr. Ground Elev. (ft)	Upstr. Pipe Cover (ft)	Downstr. Pipe Cover (ft)	Upstr. Pipe Cover Check (ft)	Downstr. Pipe Cover Check (ft)	Remarks
1	2	3	4	5	6	7	8	8a	9	10	11	12	13	14	14a	15	16	17	17a	17b	18	19	20	21	22	23	24	25	26	27	28
ELST	44442	44661	Pavement	0.09	0.90	0.08	0.08	5.0	5.0	2.89	0.24	0.00	0.24	12	0.013	0.0100	4.54	3.56	VELOCITY OK	ADEQUATE PIPE CAPACITY	40	0.40	44.90	44.50	48.69	48.78	2.35	2.84	More than 2 ft of cover	More than 2 ft of cover	
ELST	44661	44700	Pavement	0.01	0.90	0.01	0.10	5.0	5.1	2.85	0.27	0.00	0.27	12	0.013	0.0100	4.54	3.56	VELOCITY OK	ADEQUATE PIPE CAPACITY	42	0.42	44.42	44.00	48.78	48.92	2.92	3.48	More than 2 ft of cover	More than 2 ft of cover	
ELST	44700	44741	Pavement	0.02	0.90	0.01	0.11	5.0	5.3	2.90	0.31	0.00	0.31	12	0.013	0.0293	7.76	6.99	VELOCITY OK	ADEQUATE PIPE CAPACITY	99	2.90	43.90	41.00	48.92	48.87	3.58	6.43	More than 2 ft of cover	More than 2 ft of cover	
ELST	44741	44866	Pavement	0.05	1.90	0.09	0.20	5.0	5.5	2.75	0.56	0.00	0.56	12	0.013	0.1132	15.26	11.97	TRY TO REDUCE VELOCITY	ADEQUATE PIPE CAPACITY	38	4.30	40.90	36.60	48.97	39.71	6.53	1.67	More than 2 ft of cover	Low Cover - See Notes at Bottom	
ELST	44850	44870	Pavement	0.00	2.90	0.00	0.20	5.0	5.6	2.73	0.56	0.00	0.56	12	0.013	0.0091	4.33	3.40	VELOCITY OK	ADEQUATE PIPE CAPACITY	33	0.30	36.50	36.20	39.71	38.80	1.77	1.16	Low Cover - See Notes at Bottom	Low Cover - See Notes at Bottom	
Private Prop.	44870	44873	Pavement	0.00	3.90	0.00	0.20	5.0	5.7	2.70	0.56	0.00	0.56	12	0.013	0.0100	4.54	3.56	VELOCITY OK	ADEQUATE PIPE CAPACITY	40	0.40	35.06	34.66	38.80	37.00	2.30	0.90	More than 2 ft of cover	Low Cover - See Notes at Bottom	New 12-inch SD Outfall. Direct Discharge to Lake Sammamish

See WSDOT Hydraulic Manual 6-5 for explanation of columns. <http://www.wsdot.wa.gov/eesc/design/hydraulics/>

**Notes:** Column 12 represents inflow from a storm sewer line, branch, an offsite source that flows into the trunk line being analyzed. The conservative assumption is that the flow enters the storm sewer run at the upstream end of the run being analyzed.

For pipe cover calculation, Pipe cover = (Ground or Rim Elevation - Pipe invert elevation) - (pavement thickness) - (top of pipe thickness) - (pipe diameter). The pipe thickness is based on the pipe diameter per WSDOT Manual Concrete for Shallow Pipe Cover Installations Fill Height Table 8-11.2. Please specify the largest pipe thickness of the storm sewer run being analyzed.

The spreadsheet will only calculate one storm sewer line at a time. Please copy the "Blank Template" and use this for calculating new storm sewer lines. If analyzing complicated stormsewer system with multiple lateral lines to the trunk line, it is recommended that Stormshed be used to model the conveyance system. Please contact your region Hydraulic Contact.

**WARNING: START YOUR STORMSEWER RUN ON ROW 12. DO NOT SKIP ANY ROWS IN BETWEEN. USE ONE SHEET PER STORMSEWER RUN**

Please report any problems to the WSDOT HQ Hydraulics Office.

**STORM SEWER DESIGN (English Units)**

This spreadsheet accomplishes a storm sewer design using the rational method. Enter the data in the non-shaded areas only. Please use one spreadsheet per stormsewer run.

Project Name: **EAST LAKE SAMMAMISH TRAIL - SOUTH SAMMAMISH SEGMENT B**

Designed By: **CAB, 10/7/2016**  
Project Office: **N/A**

m = **6.89**    n = **0.539**    Design Storm Event = **25**    Pavement thickness (ft) = **0.33333**    Pipe Thickness (inches) = **1.25**

Location		Discharge													Drain Design										Drain Profile				Remarks		
Drain Located On	From Sta.	To Sta.	Source of Drainage	Drainage Area A (acre)	Runoff Coeff. C	CA (acre)	Sum (acre)	Tc Across Area (minutes)	Total Tc = Col. 8a + Tc across pipe length (minutes)	Rainfall Intensity (in/hr)	Runoff (cfs)	Contrib. Inflow (cfs)	Total Flow (cfs)	Pipe Dia. (in)	Manning roughness coefficient "n"	Pipe Slope (ft/ft)	Velocity Of Flow (ft/s)	Pipe Capacity (cfs)	Pipe Velocity Check (Desirable Minimum 3 ft/sec; Desirable Maximum 10 ft/sec for Column 16)	Pipe Capacity Check (Column 13 vs. Column 17)	Pipe Length*** (ft)	Elevation Change (ft)	Upstr. Invert Elev. (ft)	Downstr. Invert Elev. (ft)	Upstr. Ground Elev. (ft)	Downstr. Ground Elev. (ft)	Upstr. Pipe Cover (ft)	Downstr. Pipe Cover (ft)	Upstr. Pipe Cover Check (ft)	Downstr. Pipe Cover Check (ft)	Remarks
1	2	3	4	5	6	7	8	8a	9	10	11	12	13	14	14a	15	16	17	17a	17b	18	19	20	21	22	23	24	25	26	27	28
ELST	45182 RT	45184 RT	Pavement	0.00	0.90	0.00	0.00	5.0	0.0	2.89	0.00	0.13	0.13	18	0.013	0.0100	5.94	10.49	VELOCITY OK	ADEQUATE PIPE CAPACITY	8	0.08	44.57	44.49	48.41	49.02	1.90	2.59	Low Cover - See Notes at Bottom	More than 2 ft of cover	Contributing area from 6" Underdrain
ELST	45184 RT	45246 RT	Pavement	0.00	0.90	0.00	0.00	5.0	0.0	2.89	0.00	0.00	0.13	18	0.013	0.0150	7.28	12.85	VELOCITY OK	ADEQUATE PIPE CAPACITY	64	0.96	44.40	43.44	49.02	49.36	2.68	3.98	More than 2 ft of cover	More than 2 ft of cover	
ELST	45246 RT	45291 RT	Pavement	0.00	1.90	0.00	0.00	5.0	0.2	2.89	0.00	0.17	0.30	18	0.013	0.0487	13.11	23.15	TRY TO REDUCE VELOCITY	ADEQUATE PIPE CAPACITY	45	2.19	43.44	41.25	49.36	46.86	3.98	3.67	More than 2 ft of cover	More than 2 ft of cover	Contributing area from 6" Underdrain
ELST	45291 RT	45291 LT	Pavement	0.00	2.90	0.00	0.00	5.0	0.2	2.89	0.00	3.32	3.63	24	0.013	0.0733	19.50	61.20	TRY TO REDUCE VELOCITY	ADEQUATE PIPE CAPACITY	33	2.42	40.76	38.34	46.86	42.00	3.66	1.22	More than 2 ft of cover	Low Cover - See Notes at Bottom	Contributing area from 6" Underdrain inflows from south and north Existing 24" Diam SD Pipe conveys Unnamed Stream #11 west, where stream daylights and flow to Lake Sammamish

See WSDOT Hydraulic Manual 6-5 for explanation of columns. <http://www.wsdot.wa.gov/eesc/design/hydraulics/>

Notes: Column 12 represents inflow from a storm sewer line, branch, an offsite source that flows into the trunk line being analyzed. The conservative assumption is that the flow enters the storm sewer run at the upstream end of the run being analyzed.

For pipe cover calculation, Pipe cover = (Ground or Rim Elevation - Pipe invert elevation) - (pavement thickness) - (top of pipe thickness) - (pipe diameter). The pipe thickness is based on the pipe diameter per WSDOT Manual Concrete for Shallow Pipe Cover Installations Fill Height Table 8-11.2 Please specify the largest pipe thickness of the storm sewer run being analyzed.

The spreadsheet will only calculate one storm sewer line at a time. Please copy the "Blank Template" and use this for calculating new storm sewer lines. If analyzing complicated stormsewer system with multiple lateral lines to the trunk line, it is recommended that Stormshed be used to model the conveyance system. Please contact your region Hydraulic Contact.

**WARNING: START YOUR STORMSEWER RUN ON ROW 12. DO NOT SKIP ANY ROWS IN BETWEEN. USE ONE SHEET PER STORMSEWER RUN**

Please report any problems to the WSDOT HQ Hydraulics Office.

**STORM SEWER DESIGN (English Units)**

This spreadsheet accomplishes a storm sewer design using the rational method. Enter the data in the **non-shaded areas only**. Please use one spreadsheet per stormsewer run.

Project Name: **EAST LAKE SAMMAMISH TRAIL - SOUTH SAMMAMISH SEGMENT B**

Designed By: **CAB, 10/7/2016**  
Project Office: **N/A**

m = **6.89**    n = **0.539**    Design Storm Event = **25**    Pavement thickness (ft) = **0.33333**    Pipe Thickness (inches) = **1.25**

Location		Discharge													Drain Design										Drain Profile				Remarks		
Drain Located On	From Sta.	To Sta.	Source of Drainage	Drainage Area A (acre)	Runoff Coeff. C	CA (acre)	Sum (acre)	Tc Across Area (minutes)	Total Tc = Col. 8a + Tc across pipe length (minutes)	Rainfall Intensity (in/hr)	Runoff (cfs)	Contrib. Inflow (cfs)	Total Flow (cfs)	Pipe Dia. (in)	Manning roughness coefficient "n"	Pipe Slope (ft/ft)	Velocity Of Flow (ft/s)	Pipe Capacity (cfs)	Pipe Velocity Check (Desirable Minimum 3 ft/sec; Desirable Maximum 10 ft/sec for Column 16)	Pipe Capacity Check (Column 13 vs. Column 17)	Pipe Length*** (ft)	Elevation Change (ft)	Upstr. Invert Elev. (ft)	Downstr. Invert Elev. (ft)	Upstr. Ground Elev. (ft)	Downstr. Ground Elev. (ft)	Upstr. Pipe Cover (ft)	Downstr. Pipe Cover (ft)	Upstr. Pipe Cover Check (ft)	Downstr. Pipe Cover Check (ft)	Remarks
1	2	3	4	5	6	7	8	8a	9	10	11	12	13	14	14a	15	16	17	17a	17b	18	19	20	21	22	23	24	25	26	27	28
ELST	45072	45182	Pavement	0.05	0.90	0.04	0.04	5.0	5.0	2.89	0.13	0.00	0.13	6	0.013	0.0100	2.86	0.56	TRY TO INCREASE VELOCITY	ADEQUATE PIPE CAPACITY	110	1.10	47.22	46.12	48.70	48.41	0.54	1.35	Low Cover - See Notes at Bottom	Low Cover - See Notes at Bottom	6" Underdrain, Connection to Existing CB
ELST	45187	45246	Pavement	0.02	0.90	0.02	0.06	5.0	5.6	2.71	0.17	0.00	0.17	6	0.013	0.0100	2.86	0.56	TRY TO INCREASE VELOCITY	ADEQUATE PIPE CAPACITY	59	0.59	46.89	46.30	48.41	48.12	0.58	0.88	Low Cover - See Notes at Bottom	Low Cover - See Notes at Bottom	6" Underdrain, Connection to New CB Type 1
ELST	45250	45291	Pavement	0.02	0.90	0.01	0.08	5.0	6.0	2.63	0.21	0.00	0.21	6	0.013	0.0100	2.86	0.56	TRY TO INCREASE VELOCITY	ADEQUATE PIPE CAPACITY	41	0.41	46.00	45.59	48.12	46.86	1.18	0.33	Low Cover - See Notes at Bottom	Not Enough Cover - Need to Revise Pipe Elevations	6" Underdrain, Connection to Existing CB, exit pipe conveys west beneath trail (Unnamed Stream #11)

See WSDOT Hydraulic Manual 6-5 for explanation of columns. <http://www.wsdot.wa.gov/eesc/design/hydraulics/>

Notes: Column 12 represents inflow from a storm sewer line, branch, an offsite source that flows into the trunk line being analyzed. The conservative assumption is that the flow enters the storm sewer run at the upstream end of the run being analyzed.

For pipe cover calculation, Pipe cover = (Ground or Rim Elevation - Pipe invert elevation) - (pavement thickness) - (top of pipe thickness) - (pipe diameter). The pipe thickness is based on the pipe diameter per WSDOT Manual Concrete for Shallow Pipe Cover Installations Fill Height Table 8-11.2. Please specify the largest pipe thickness of the storm sewer run being analyzed.

The spreadsheet will only calculate one storm sewer line at a time. Please copy the "Blank Template" and use this for calculating new storm sewer lines. If analyzing complicated stormsewer system with multiple lateral lines to the trunk line, it is recommended that Stormshed be used to model the conveyance system. Please contact your region Hydraulic Contact.

**WARNING: START YOUR STORMSEWER RUN ON ROW 12. DO NOT SKIP ANY ROWS IN BETWEEN. USE ONE SHEET PER STORMSEWER RUN**

Please report any problems to the WSDOT HQ Hydraulics Office.



**STORM SEWER DESIGN (English Units)**

This spreadsheet accomplishes a storm sewer design using the rational method. Enter the data in the **non-shaded areas only**. Please use one spreadsheet per stormsewer run.

Project Name: **EAST LAKE SAMMAMISH TRAIL - SOUTH SAMMAMISH SEGMENT B**

Designed By: **CAB, 10/7/2016**  
Project Office: **N/A**

m = **6.89**    n = **0.539**    Design Storm Event = **25**    Pavement thickness (ft) = **0.33333**    Pipe Thickness (inches) = **1.25**

Location		Discharge													Drain Design						Drain Profile				Remarks						
Drain Located On	From Sta.	To Sta.	Source of Drainage	Drainage Area A (acre)	Runoff Coeff. C	CA (acre)	Sum (acre)	T <sub>c</sub> Across Area (minutes)	Total T <sub>c</sub> = Col. 8a + T <sub>c</sub> across pipe length (minutes)	Rainfall Intensity (in/hr)	Runoff (cfs)	Contrib. Inflow (cfs)	Total Flow (cfs)	Pipe Dia. (in)	Manning roughness coefficient "n"	Pipe Slope (ft/ft)	Velocity Of Flow (ft/s)	Pipe Capacity (cfs)	Pipe Velocity Check (Desirable Minimum 3 ft/sec; Desirable Maximum 10 ft/sec for Column 16)	Pipe Capacity Check (Column 13 vs. Column 17)	Pipe Length*** (ft)	Elevation Change (ft)	Upstr. Invert Elev. (ft)	Downstr. Invert Elev. (ft)	Upstr. Ground Elev. (ft)	Downstr. Ground Elev. (ft)	Upstr. Pipe Cover (ft)	Downstr. Pipe Cover (ft)	Upstr. Pipe Cover Check (ft)	Downstr. Pipe Cover Check (ft)	Remarks
ELST	45393	45291	Pavement	0.05	0.90	0.04	0.04	5.0	5.0	2.89	0.12	0.00	0.12	6	0.013	0.0100	2.96	0.56	TRY TO INCREASE VELOCITY	ADEQUATE PIPE CAPACITY	102	1.02	45.49	44.47	47.00	46.86	0.57	1.45	Low Cover - See Notes at Bottom	Low Cover - See Notes at Bottom	6' Underdrain, Connection to Existing CB, exit pipe conveys west that beneath trail (Unnamed Stream #11)

See WSDOT Hydraulic Manual 6-5 for explanation of columns. <http://www.wsdot.wa.gov/eesc/design/hydraulics/>

Notes: Column 12 represents inflow from a storm sewer line, branch, an offsite source that flows into the trunk line being analyzed. The conservative assumption is that the flow enters the storm sewer run at the upstream end of the run being analyzed.

For pipe cover calculation, Pipe cover = (Ground or Rim Elevation - Pipe invert elevation) - (pavement thickness) - (top of pipe thickness) - (pipe diameter). The pipe thickness is based on the pipe diameter per WSDOT Manual Concrete for Shallow Pipe Cover Installations Fill Height Table 8-11.2. Please specify the largest pipe thickness of the storm sewer run being analyzed.

The spreadsheet will only calculate one storm sewer line at a time. Please copy the "Blank Template" and use this for calculating new storm sewer lines. If analyzing complicated stormsewer system with multiple lateral lines to the trunk line, it is recommended that Stormshed be used to model the conveyance system. Please contact your region Hydraulic Contact.

**WARNING: START YOUR STORMSEWER RUN ON ROW 12. DO NOT SKIP ANY ROWS IN BETWEEN. USE ONE SHEET PER STORMSEWER RUN**

Please report any problems to the WSDOT HQ Hydraulics Office.

**STORM SEWER DESIGN (English Units)**

This spreadsheet accomplishes a storm sewer design using the rational method. Enter the data in the **non-shaded areas only**. Please use one spreadsheet per stormsewer run.

Project Name: **EAST LAKE SAMMAMISH TRAIL - SOUTH SAMMAMISH SEGMENT B**

Designed By: **CAB, 10/7/2016**  
Project Office: **N/A**

m = **6.89**    n = **0.539**    Design Storm Event = **25**    Pavement thickness (ft) = **0.33333**    Pipe Thickness (inches) = **1.25**

Location		Discharge													Drain Design						Drain Profile				Remarks								
Drain Located On	From Sta.	To Sta.	Source of Drainage	Drainage Area A (acre)	Runoff Coeff. C	CA (acre)	Sum (acre)	Tc Across Area (minutes)	Total Tc = Col. 8a + Tc across pipe length (minutes)	Rainfall Intensity (in/hr)	Runoff (cfs)	Contrib. Inflow (cfs)	Total Flow (cfs)	Pipe Dia. (in)	Manning roughness coefficient "n"	Pipe Slope (ft/ft)	Velocity Of Flow (ft/s)	Pipe Capacity (cfs)	Pipe Velocity Check (Desirable Minimum 3 ft/sec; Desirable Maximum 10 ft/sec for Column 16)	Pipe Capacity Check (Column 13 vs. Column 17)	Pipe Length*** (ft)	Elevation Change (ft)	Upstr. Invert Elev. (ft)	Downstr. Invert Elev. (ft)	Upstr. Ground Elev. (ft)	Downstr. Ground Elev. (ft)	Upstr. Pipe Cover (ft)	Downstr. Pipe Cover (ft)	Upstr. Pipe Cover Check (ft)	Downstr. Pipe Cover Check (ft)	Remarks		
1	2	3	4	5	6	7	8	8a	9	10	11	12	13	14	14a	15	16	17	17a	17b	18	19	20	21	22	23	24	25	26	27	28		
ELST	45397	45575	Pavement	0.08	0.90	0.07	0.07	5.0	5.0	2.89	0.20	0.00	0.20	6	0.013	0.0031	1.59	0.31	TRY TO INCREASE VELOCITY	ADEQUATE PIPE CAPACITY	178	0.55	45.49	44.94	47.14	48.41	0.71		2.53		Low Cover - See Notes at Bottom	More than 2 ft of cover	6' Underdrain, discharge to Unnamed Stream #13 east of trail

See WSDOT Hydraulic Manual 6-5 for explanation of columns. <http://www.wsdot.wa.gov/eesc/design/hydraulics/>

Notes: Column 12 represents inflow from a storm sewer line, branch, an offsite source that flows into the trunk line being analyzed. The conservative assumption is that the flow enters the storm sewer run at the upstream end of the run being analyzed.

For pipe cover calculation, Pipe cover = (Ground or Rim Elevation - Pipe invert elevation) - (pavement thickness) - (top of pipe thickness) - (pipe diameter). The pipe thickness is based on the pipe diameter per WSDOT Manual Concrete for Shallow Pipe Cover Installations Fill Height Table 8-11.2. Please specify the largest pipe thickness of the storm sewer run being analyzed.

The spreadsheet will only calculate one storm sewer line at a time. Please copy the "Blank Template" and use this for calculating new storm sewer lines. If analyzing complicated stormsewer system with multiple lateral lines to the trunk line, it is recommended that Stormshed be used to model the conveyance system. Please contact your region Hydraulic Contact.

**WARNING: START YOUR STORMSEWER RUN ON ROW 12. DO NOT SKIP ANY ROWS IN BETWEEN. USE ONE SHEET PER STORMSEWER RUN**

Please report any problems to the WSDOT HQ Hydraulics Office.

**STORM SEWER DESIGN (English Units)**

This spreadsheet accomplishes a storm sewer design using the rational method. Enter the data in the **non-shaded areas only**. Please use one spreadsheet per stormsewer run.

Project Name: **EAST LAKE SAMMAMISH TRAIL - SOUTH SAMMAMISH SEGMENT B**

Designed By: **CAB, 10/7/2016**  
Project Office: **N/A**

m = **6.89**    n = **0.539**    Design Storm Event = **25**    Pavement thickness (ft) = **0.33333**    Pipe Thickness (inches) = **1.25**

Location		Discharge / Drain Design													Drain Profile								Remarks									
Drain Located On	From Sta.	To Sta.	Source of Drainage	Drainage Area A (acre)	Runoff Coeff. C	CA (acre)	Sum (acre)	Tc Across Area (minutes)	Total Tc = Col. 8a + Tc across pipe length (minutes)	Rainfall Intensity (in/hr)	Runoff (cfs)	Contrib. Inflow (cfs)	Total Flow (cfs)	Pipe Dia. (in)	Manning roughness coefficient "n"	Pipe Slope (ft/ft)	Velocity Of Flow (ft/s)	Pipe Capacity (cfs)	Pipe Velocity Check (Desirable Minimum 3 ft/sec; Desirable Maximum 10 ft/sec for Column 16)	Pipe Capacity Check (Column 13 vs. Column 17)	Pipe Length*** (ft)	Elevation Change (ft)	Upstr. Invert Elev. (ft)	Downstr. Invert Elev. (ft)	Upstr. Ground Elev. (ft)	Downstr. Ground Elev. (ft)	Upstr. Pipe Cover (ft)	Downstr. Pipe Cover (ft)	Upstr. Pipe Cover Check (ft)	Downstr. Pipe Cover Check (ft)	Remarks	
ParkingArea	45397 RT	45631 RT	Pavement	0.00	0.90	0.00	0.00	5.0	0.0	2.89	0.00	3.00	3.00	12	0.013	0.0266	7.40	5.80	VELOCITY OK	ADEQUATE PIPE CAPACITY	94	2.50	50.50	48.00	54.56	52.40	2.62	2.96	More than 2 ft of cover	More than 2 ft of cover	Est. 3 cfs for 25yr storm flow from 7.8 acres off-site catchment	
Parking/ELST	45631 RT	45632 LT	Pavement	0.00	0.90	0.00	0.00	5.0	0.2	2.89	0.00	0.00	3.00	12	0.013	0.0250	7.17	5.63	VELOCITY OK	ADEQUATE PIPE CAPACITY	38	0.95	44.50	43.55	52.40	46.80	6.46	1.81	More than 2 ft of cover	Low Cover - See Notes at Bottom		
ELST/Private	45632 LT	45635 LT	Trail	0.00	0.90	0.00	0.00	5.0	0.3	2.89	0.00	0.00	3.00	12	0.013	0.0560	10.73	8.42	TRY TO REDUCE VELOCITY	ADEQUATE PIPE CAPACITY	100	5.60	43.50	37.90	46.80	40.00	1.86	0.66	Low Cover - See Notes at Bottom	Low Cover - See Notes at Bottom		

See WSDOT Hydraulic Manual 6-5 for explanation of columns. <http://www.wsdot.wa.gov/eesc/design/hydraulics/>

**Notes:**  
 Column 12 represents inflow from a storm sewer line, branch, an offsite source that flows into the trunk line being analyzed. The conservative assumption is that the flow enters the storm sewer run at the upstream end of the run being analyzed.

For pipe cover calculation, Pipe cover = (Ground or Rim Elevation - Pipe invert elevation) - (pavement thickness) - (top of pipe thickness) - (pipe diameter). The pipe thickness is based on the pipe diameter per WSDOT Manual Concrete for Shallow Pipe Cover Installations Fill Height Table 8-11.2. Please specify the largest pipe thickness of the storm sewer run being analyzed.

The spreadsheet will only calculate one storm sewer line at a time. Please copy the "Blank Template" and use this for calculating new storm sewer lines. If analyzing complicated stormsewer system with multiple lateral lines to the trunk line, it is recommended that Stormshed be used to model the conveyance system. Please contact your region Hydraulic Contact.

**WARNING: START YOUR STORMSEWER RUN ON ROW 12. DO NOT SKIP ANY ROWS IN BETWEEN. USE ONE SHEET PER STORMSEWER RUN**

Please report any problems to the WSDOT HQ Hydraulics Office.

**STORM SEWER DESIGN (English Units)**

This spreadsheet accomplishes a storm sewer design using the rational method. Enter the data in the **non-shaded areas only**. Please use one spreadsheet per stormsewer run.

Project Name: **EAST LAKE SAMMAMISH TRAIL - SOUTH SAMMAMISH SEGMENT B**

Designed By: **CAB, 10/7/2016**  
Project Office: **N/A**

m = **6.89**    n = **0.539**    Design Storm Event = **25**    Pavement thickness (ft) = **0.33333**    Pipe Thickness (inches) = **1.25**

Location		Discharge													Drain Design						Drain Profile				Remarks						
Drain Located On	From Sta.	To Sta.	Source of Drainage	Drainage Area A (acre)	Runoff Coeff. C	CA (acre)	Sum (acre)	Tc Across Area (minutes)	Total Tc = Col. 8a + Tc across pipe length (minutes)	Rainfall Intensity (in/hr)	Runoff (cfs)	Contrib. Inflow (cfs)	Total Flow (cfs)	Pipe Dia. (in)	Manning roughness coefficient "n"	Pipe Slope (ft/ft)	Velocity Of Flow (ft/s)	Pipe Capacity (cfs)	Pipe Velocity Check (Desirable Minimum 3 ft/sec; Desirable Maximum 10 ft/sec for Column 16)	Pipe Capacity Check (Column 13 vs. Column 17)	Pipe Length*** (ft)	Elevation Change (ft)	Upstr. Invert Elev. (ft)	Downstr. Invert Elev. (ft)	Upstr. Ground Elev. (ft)	Downstr. Ground Elev. (ft)	Upstr. Pipe Cover (ft)	Downstr. Pipe Cover (ft)	Upstr. Pipe Cover Check (ft)	Downstr. Pipe Cover Check (ft)	Remarks
ELST	45750	45635	Pavement	0.05	0.90	0.05	0.05	5.0	5.0	2.89	0.13	0.00	0.13	6	0.013	0.0050	2.02	0.40	TRY TO INCREASE VELOCITY	ADEQUATE PIPE CAPACITY	115	0.58	45.49	44.92	47.20	46.80	0.77	0.95	Low Cover - See Notes at Bottom	Low Cover - See Notes at Bottom	6' Underdrain, discharge to Unnamed Stream #13 east of trail

See WSDOT Hydraulic Manual 6-5 for explanation of columns. <http://www.wsdot.wa.gov/eesc/design/hydraulics/>

Notes: Column 12 represents inflow from a storm sewer line, branch, an offsite source that flows into the trunk line being analyzed. The conservative assumption is that the flow enters the storm sewer run at the upstream end of the run being analyzed.

For pipe cover calculation, Pipe cover = (Ground or Rim Elevation - Pipe invert elevation) - (pavement thickness) - (top of pipe thickness) - (pipe diameter). The pipe thickness is based on the pipe diameter per WSDOT Manual Concrete for Shallow Pipe Cover Installations Fill Height Table 8-11.2. Please specify the largest pipe thickness of the storm sewer run being analyzed.

The spreadsheet will only calculate one storm sewer line at a time. Please copy the "Blank Template" and use this for calculating new storm sewer lines. If analyzing complicated stormsewer system with multiple lateral lines to the trunk line, it is recommended that Stormshed be used to model the conveyance system. Please contact your region Hydraulic Contact.

**WARNING: START YOUR STORMSEWER RUN ON ROW 12. DO NOT SKIP ANY ROWS IN BETWEEN. USE ONE SHEET PER STORMSEWER RUN**

Please report any problems to the WSDOT HQ Hydraulics Office.

### 2-5.4 Rainfall Intensity

After the appropriate storm frequency for the design has been determined (see [Chapter 1](#)) and the time of concentration has been calculated, the rainfall intensity can be calculated. Designers should never use a time of concentration that is less than 5 minutes for intensity calculations, even when the calculated time of concentration is less than 5 minutes. The 5-minute limit is based on two ideas:

1. Shorter times give unrealistic intensities. Many IDF curves are constructed from curve smoothing equations and not based on actual data collected at intervals shorter than 15 to 30 minutes. To make the curves shorter, involves extrapolation, which is not reliable.
2. It takes time for rainfall to generate into runoff within a defined basin, thus it would not be realistic to have less than 5 minutes for a time of concentration.

It should be noted that the rainfall intensity at any given time is the average of the most intense period enveloped by the time of concentration and is not the instantaneous rainfall. [Equation 2-4](#) is the equation for calculating rainfall intensity.

$$I = \frac{m}{(T_c)^n} \quad (2-4)$$

Where:

- I = rainfall intensity in inches per hour (millimeters per hour)
- T<sub>c</sub> = time of concentration in minutes
- m & n = coefficients in dimensionless units ([Figures 2-5.4A](#) and [2-5.4B](#))

The coefficients (m and n) have been determined for all major cities for the 2-, 5-, 10-, 25-, 50-, and 100-year mean recurrence intervals (MRI). The coefficients listed are accurate from 5-minute durations to 1,440-minute durations (24 hours). These equations were developed from the *1973 National Oceanic and Atmospheric Administration Atlas 2, Precipitation-Frequency Atlas of the Western United States, Volume IX-Washington*.

With the Region Hydraulic Engineer's assistance, the designer should interpolate between the two or three nearest cities listed in the tables when working on a project that is in a location not listed on the table. If the designer must do an analysis with a T<sub>c</sub> greater than 1,440 minutes, the Rational method should not be used.



Location	2-Year MRI		5-Year MRI		10-Year MRI		25-Year MRI		50-Year MRI		100-Year MRI	
	m	n	m	n	m	n	m	n	m	n	m	n
Aberdeen and Hoquiam	5.10	0.488	6.22	0.488	7.06	0.487	8.17	0.487	9.02	0.487	9.86	0.487
Bellingham	4.29	0.549	5.59	0.555	6.59	0.559	7.90	0.562	8.89	0.563	9.88	0.565
Bremerton	3.79	0.480	4.84	0.487	5.63	0.490	6.68	0.494	7.47	0.496	8.26	0.498
Centralia and Chehalis	3.63	0.506	4.85	0.518	5.76	0.524	7.00	0.530	7.92	0.533	8.86	0.537
Clarkston and Colfax	5.02	0.628	6.84	0.633	8.24	0.635	10.07	0.638	11.45	0.639	12.81	0.639
Colville	3.48	0.558	5.44	0.593	6.98	0.610	9.07	0.626	10.65	0.635	12.26	0.642
Ellensburg	2.89	0.590	5.18	0.631	7.00	0.649	9.43	0.664	11.30	0.672	13.18	0.678
Everett	3.69	0.556	5.20	0.570	6.31	0.575	7.83	0.582	8.96	0.585	10.07	0.586
Forks	4.19	0.410	5.12	0.412	5.84	0.413	6.76	0.414	7.47	0.415	8.18	0.416
Hoffstadt Cr. (SR 504)	3.96	0.448	5.21	0.462	6.16	0.469	7.44	0.476	8.41	0.480	9.38	0.484
Hoodsport	4.47	0.428	5.44	0.428	6.17	0.427	7.15	0.428	7.88	0.428	8.62	0.428
Kelso and Longview	4.25	0.507	5.50	0.515	6.45	0.509	7.74	0.524	8.70	0.526	9.67	0.529
Leavenworth	3.04	0.530	4.12	0.542	5.62	0.575	7.94	0.594	9.75	0.606	11.08	0.611
Metaline Falls	3.36	0.527	4.90	0.553	6.09	0.566	7.45	0.570	9.29	0.592	10.45	0.591
Moses Lake	2.61	0.583	5.05	0.634	6.99	0.655	9.58	0.671	11.61	0.681	13.63	0.688
Mt. Vernon	3.92	0.542	5.25	0.552	6.26	0.557	7.59	0.561	8.60	0.564	9.63	0.567
Naselle	4.57	0.432	5.67	0.441	6.14	0.432	7.47	0.443	8.05	0.440	8.91	0.436
Olympia	3.82	0.466	4.86	0.472	5.62	0.474	6.63	0.477	7.40	0.478	8.17	0.480
Omak	3.04	0.583	5.06	0.618	6.63	0.633	8.74	0.647	10.35	0.654	11.97	0.660
Pasco and Kennewick	2.89	0.590	5.18	0.631	7.00	0.649	9.43	0.664	11.30	0.672	13.18	0.678
Port Angeles	4.31	0.530	5.42	0.531	6.25	0.531	7.37	0.532	8.19	0.532	9.03	0.532
Poulsbo	3.83	0.506	4.98	0.513	5.85	0.516	7.00	0.519	7.86	0.521	8.74	0.523
Queets	4.26	0.422	5.18	0.423	5.87	0.423	6.79	0.423	7.48	0.423	8.18	0.424
Seattle	3.56	0.515	4.83	0.531	5.62	0.530	6.89	0.539	7.88	0.545	8.75	0.5454
Sequim	3.50	0.551	5.01	0.569	6.16	0.577	7.69	0.585	8.88	0.590	10.04	0.593
Snoqualmie Pass	3.61	0.417	4.81	0.435	6.56	0.459	7.72	0.459	8.78	0.461	10.21	0.476
Spokane	3.47	0.556	5.43	0.591	6.98	0.609	9.09	0.626	10.68	0.635	12.33	0.643
Stevens Pass	4.73	0.462	6.09	0.470	8.19	0.500	8.53	0.484	10.61	0.499	12.45	0.513
Tacoma	3.57	0.516	4.78	0.527	5.70	0.533	6.93	0.539	7.86	0.542	8.79	0.545
Vancouver	2.92	0.477	4.05	0.496	4.92	0.506	6.06	0.515	6.95	0.520	7.82	0.525
Walla Walla	3.33	0.569	5.54	0.609	7.30	0.627	9.67	0.645	11.45	0.653	13.28	0.660
Wenatchee	3.15	0.535	4.88	0.566	6.19	0.579	7.94	0.592	9.32	0.600	10.68	0.605
Yakima	3.86	0.608	5.86	0.633	7.37	0.644	9.40	0.654	10.93	0.659	12.47	0.663

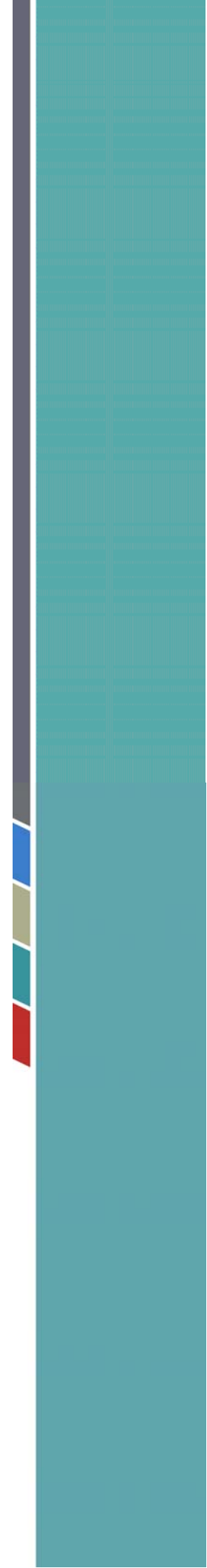
Index to Rainfall Coefficients (English Units)

Figure 2-5.4A

DRAFT

## Appendix D

Fish Passage Communications with  
Muckleshoot Indian Tribe







## King County

### Parks and Recreation Division

Department of Natural Resources and Parks

King Street Center, KSC-NR-0700

201 South Jackson Street

Seattle, WA 98104-3855

**206-477-4527** Fax 206-296-8686

TTY Relay: 711

May 28, 2015

Karen Walter

Watersheds and Land Use Team Leader

Muckleshoot Indian Tribe Fisheries Division Habitat Program

39015 172<sup>nd</sup> Ave SE

Auburn, WA 98092

Dear Karen:

Thank you for touring the East Lake Sammamish Trail – Segment A corridor with Paul Fendt, Bob Peterson and me on April 15<sup>th</sup>, 2015 to review the proposed replacement of culverts along the corridor. We appreciate the time you spent with us to review each individual location and your willingness to listen to our challenges at each location. I also want to thank you for providing your feedback and helping us to understand your concerns.

In response to your request Paul Fendt has prepared the enclosed reformatted table to address the concern regarding how the data was presented. Another concern you raised was the timing of the walk through and you requested that we do the next segment as early in the process as practicable.

We are currently wrapping up construction on the north segment and will shortly begin the design phase of South Segment 'B'. We would like to inquire about your availability to conduct a walk through on that segment. Please let me know if you have any time available in July or mid-August to take a tour of the next segment.

We look forward to speaking with you in greater detail regarding our culvert replacement plans in the next segment in the near future. Please do not hesitate to contact me at [frank.overton@kingcounty.gov](mailto:frank.overton@kingcounty.gov) or at 206-477-3552. Thank you.

Sincerely,

Frank D. Overton

Capital Project Managing Supervisor

Enclosure

cc: Paul Fendt, P.E., Senior Consultant, Parametrix  
Bob Peterson, Tribal Relations Liaison, Department of Natural Resources and Parks (DNRP)  
Gina Auld, Capital Project Manager, Parks and Recreation Division, DNRP





## TECHNICAL MEMORANDUM

**DATE:** May 18, 2015  
**TO:** King County  
**FROM:** Paul Fendt  
**SUBJECT:** Evaluation of Existing Drainage Structures for Replacement in the South Sammamish Segment  
**CC:** Craig Buitrago, Jenny Bailey  
**PROJECT NUMBER:** 554-1521-075 (20/05)  
**PROJECT NAME:** East Lake Sammamish Trail

### INTRODUCTION

King County received feedback on its assessment of trail culverts from commenters on the Substantial Shoreline Development Permit with the City of Sammamish. In response, King County Parks prepared an enhanced, supplemental analysis to collect data and to evaluate the existing drainage structures located on the East Lake Sammamish Trail (ELST) South Sammamish Segment. In this analysis, the County further identified drainage structures suited for potential fish passage improvements (Technical Memorandum to King County dated February 26, 2015). The process consists of applying screening criteria that evaluates critical characteristics for considering replacement of non-passable structures with a fish-passable culvert and also removes from consideration those structures that do not serve a natural or modified stream.

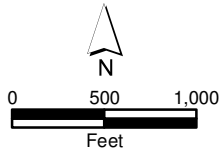
The purpose of this technical memorandum is to provide a summary table of the screening results that is compared to and related to the potential fish-bearing waters information previously prepared. No new information is provided and no modifications or updates have been made. Table 1 shows the full list of structures in the South Sammamish Segment. Some structures in the original analysis had slightly different stationing numbers, which have been used in Table 1 and are related to the new numbers now being used. Figure 1 shows the location of the structures in South Sammamish Segment A, which are the subject of the current permitting action. Table 1 shows all of the structures analyzed. Table 2 provides a summary of the WDNR stream typing maps and status of the existing structures.



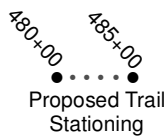
Path: P:\554 1521 075 SammamishTrail\Figures 1A 1B\Figure 1A\_SSamamish TDA Segment A Basins.mxd

Source: King County, City of Sammamish, National Geographic Society, I-cubed.

**Parametrix**



- South Sammamish Segment A Project Location
- Stream Crossing Field-verified by Parametrix
- - - Stream Crossing Not Found within Trail Corridor
- City of Sammamish Drainage Basin



**Figure 1A  
Drainage Structure  
Locations**

Table 1. Summary of Structure Screens

Structures in the South Sammamish Segment (41) <sup>1</sup>	Structures included in the early stream width analysis (29) <sup>2</sup>	Structures meeting channel width criteria (23)	Structures passing replacement screens (8)	Structures meeting channel width criteria but failing screens (15)	WDNR stream typing <sup>3</sup>	Stream name or identifier
218+45	218+45	218+45		218+45		
220+00RT	220+00RT	220+00RT		220+00RT		
224+00	224+00					
229+85	229+90					
239+60	239+60	239+60	239+60		F	0163 S <sup>4</sup>
241+15	241+15	241+15	241+15		N	0163 N <sup>4</sup>
256+40	256+40	256+40		256+40	N	
270+00	270+00				N	
276+00						
290+05	290+05					
298+50						
308+10						
310+00						
315+90	315+90	315+90		315+90		
316+65	316+65	316+65		316+65	N	
320+75						
324+75						
330+00						
343+00						
350+50						
352+25	352+25					
356+65	356+65	356+65		356+65		
364+25						
366+75	366+75	366+75		366+75		
370+00						
378+40	378+40	378+40	378+40		F	Pine Lake Creek
383+50	383+47	383+50		383+50		
384+50RT	384+50RT	384+50RT		384+50RT		
385+80	385+80	385+80		385+80		
401+00	401+00	401+00	401+00		F	0155
411+10	411+10	411+10	411+10		F	Ebright Creek
426+40	423+40	423+40	426+40		F	Zaccuse Creek
431+60	431+60	431+60		431+60	N	
436+10						
441+50	440+20	440+20	441+50		F	George Davis Cr
450+00	448+73	448+73		448+73		
453+00	451+50	451+50		451+50		
454+50	453+32					
456+00	454+60	454+60		454+60		
460+20	459+03	459+03		459+03		
464+15	464+13	464+13	464+15		n/a	0143L

<sup>1</sup>Using current stationing numbers from “updated 60 percent plans”; from the February 26, 2015 Technical Memorandum

<sup>2</sup>Using stationing from the 2008 “30 percent design plans”

<sup>3</sup>Streams not shown on the WDNR typing maps have no typing designation

<sup>4</sup>Streams 163N and 163S are branches or distributaries of the same channel that crosses the trail in two locations. The stream mapping is inconsistent across numerous sources, but the typing and structure analysis are correct.

Eight structures met all the screening criteria to be considered for replacement (see Table 1) and will be further evaluated to confirm the replacement approach. Six of those eight will be replaced plus two additional structures

for a total of eight replaced. Fifteen of the 23 structures meeting the channel width criteria do not meet the screening criteria to be considered for replacement. Of these 15, 12 are not shown on the WDNR stream typing maps and the remaining three were rated “N” or non-fish-bearing.

The stream types for the structures meeting the screening criteria is shown on Table 2, which indicates that six of the eight structures are Type F, one is Type N, and one is not typed or shown on the maps.

**Table 2. Summary of Structures and Proposed Status**

Structures passing all screens	Stream name	WDNR stream typing	Proposal (reason)	Comments
239+60	0163S	Type F <sup>1</sup>	Not replaced (no habitat gain without other replacements outside of trail corridor); additional culverts replaced at Zaccuse and Pine Lake Creeks	Channel combines immediately downstream of trail; barrier immediately upstream
241+15	0163N	Type N <sup>2</sup>	Not replaced (no habitat gain without other replacements outside of trail corridor); additional culverts replaced at Zaccuse and Pine Lake Creeks	Channel combines immediately downstream of trail; channel in culvert immediately downstream of trail
378+40	Pine Lake Creek	Type F	Replace (pass screens, named, Type F); Additional structure to be replaced outside of trail corridor	Two culverts proposed will provide complementary benefits for comprehensive habitat gain
401+00	Stream 155	Type F	Replace (pass screens, named, Type F)	Downstream reach to lake is in a pipe that must be replaced to gain benefit
411+10	Ebright Creek	Type F	Replace (pass screens, named, Type F)	
426+40	Zaccuse Creek	Type F	Replace (pass screens, named, Type F); Additional structure to be replaced outside of trail corridor	Two culverts proposed will provide complementary benefits for comprehensive habitat gain
441+50	George Davis Creek	Type F	Replace (pass screens, named, Type F)	
464+15	Stream 143L	not typed	Replace (pass screens)	

<sup>1</sup> Type F is defined by WDNR as a stream or waterbody that is known to be used by fish, or met the physical criteria to be potentially used by fish.

<sup>2</sup> type N is defined by WDNR as a stream or that does not meet the physical criteria of a Type F stream, including streams that have been proven not to contain fish using methods described in Forest Practices Board Manual Section 13.



## TECHNICAL MEMORANDUM

**DATE:** February 26, 2015  
**TO:** King County  
**FROM:** Paul Fendt  
**SUBJECT:** Evaluation of Existing Drainage Structures for Replacement in the South Sammamish Segment  
**CC:** Craig Buitrago, Jenny Bailey  
**PROJECT NUMBER:** 554-1521-075 (20/05)  
**PROJECT NAME:** East Lake Sammamish Trail

### INTRODUCTION

King County received feedback on its assessment of trail culverts from commenters to the critical areas permit applications with the City of Sammamish. King County Parks has directed that an enhanced, supplemental analysis be made to collect data and evaluate the existing drainage structures located on the East Lake Sammamish Trail (ELST) South Sammamish Segment to further identify drainage structures requiring and suited for potential fish passage improvements. The process consists of screening criteria, each of which evaluates a critical characteristic for considering a viable structure replacement with a fish-passable culvert and removes from consideration those structures that do not serve a natural or modified stream.

The term “drainage structure” is used to refer to any pipe, storm sewer, culvert, bridge, or other water conveyance device or path that moves water from one side of the trail embankment to the other. This term is used so as to not presuppose that every water conveyance device is a “culvert” that conveys natural or modified streams and waterways. Conveyance devices also provide local land and roadway drainage, prevent standing water from collecting along constructed embankments, or are a continuation of a storm sewer system from a developed area. Developed and constructed artificial drainage systems often necessarily have the same dimensions and characteristics of waterways meeting the stream definitions. While usually only flowing in response to rain and runoff from developed areas, at times these built systems collect drainage from seeps and springs or stormwater facilities, thereby flowing seasonally for more extended times. The purpose of this evaluation is to inform a clearer distinction between natural streams and constructed drainage systems and identify segments that have characteristics (i.e. hydrology, catchment area, adequate channel and buffer width, etc.) that could support a viable enhanced stream or restore a lost stream, thus supporting a structure replacement.

Each of the screening steps were performed on all 41 structures in the South Sammamish Segment (Figures 1A and 1B), which includes nine structures in South Sammamish Segment A, shown as the southern-most nine structures on Figure 1A (stations 218+45 through 276+00). Consequently, if additional data is found that may change a decision on a culvert for one screen, other screens may be reviewed to confirm the original decision. This analysis was a combination of desk top reviews of maps and plans, site photographs, and personal knowledge of the sites based on multiple field visits. Additional field verification may be needed to confirm findings in selected areas.

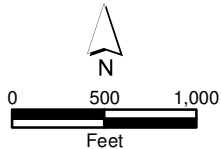




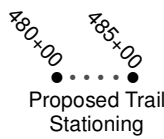
Path: P:\554 1521 075 SammamishTrail\Figures 1A 1B\Figure 1A SSammamish TDA Segment A Basins.mxd

Source: King County, City of Sammamish, National Geographic Society, I-cubed.

**Parametrix**

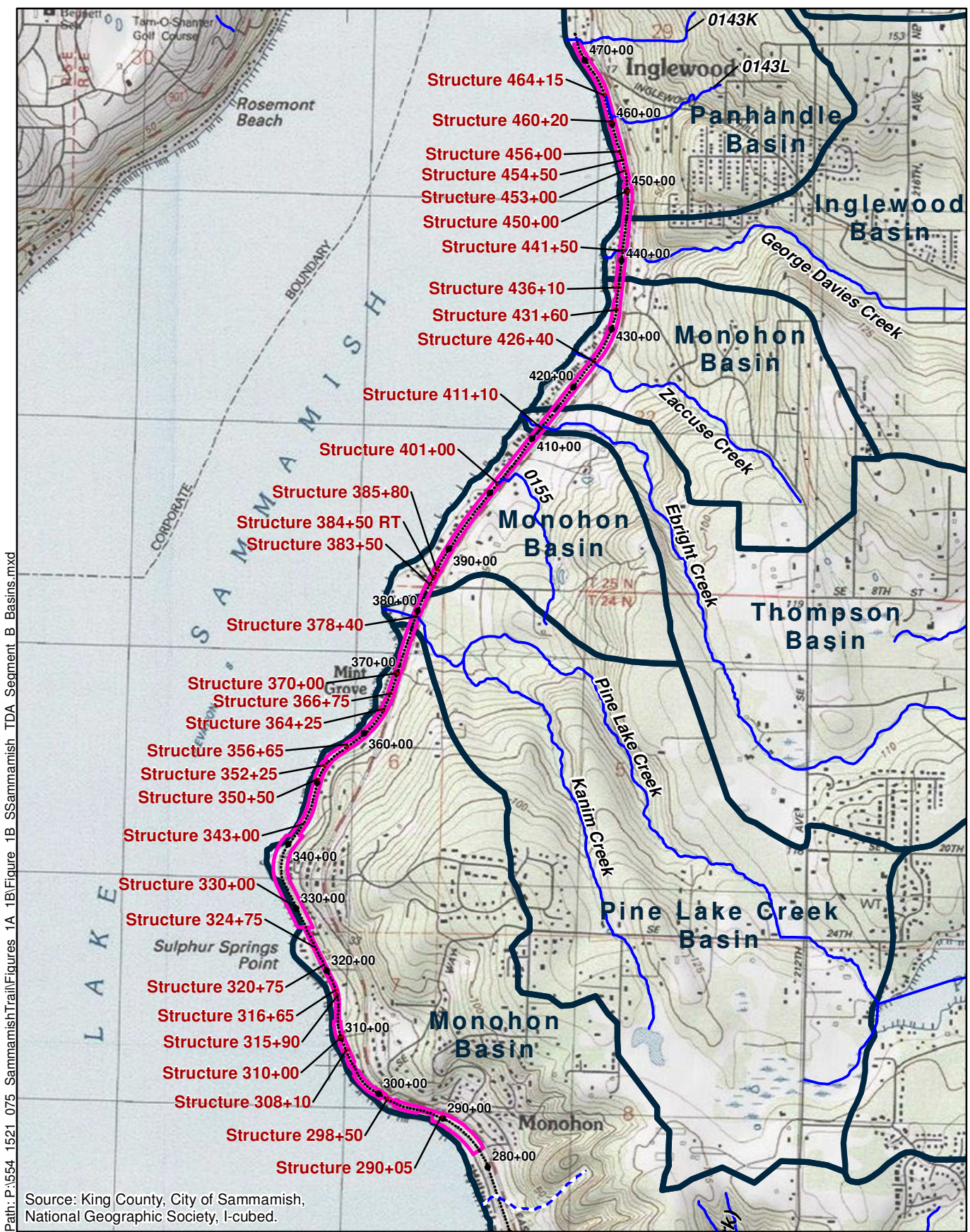


- South Sammamish Segment A Project Location
- Stream Crossing Field-verified by Parametrix
- - - Stream Crossing Not Found within Trail Corridor
- City of Sammamish Drainage Basin

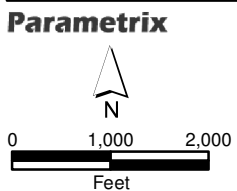


**Figure 1A  
Drainage Structure  
Locations**





Path: P:\554 1521 075 SammamishTrail\Figures 1A 1B\Figure 1B\_SSamamish TDA Segment B Basins.mxd



- South Sammamish Segment B Project Location
- Stream Crossing Field-verified by Parametrix
- - - Stream Crossing Not Found within Trail Corridor
- City of Sammamish Drainage Basin

- ● ● ● ● Proposed Trail Stationing

**Figure 1B  
Drainage Structure Locations**

Structures remaining after the screening are subject to detailed site-specific evaluations. The characteristics evaluated in the screens would still be used to further consider replacement or exclusion - additional information may come to light that would change the conclusions of the screening process. In addition, further evaluation will consider the overall benefits to the entire system provided by replacing the trail structure, which will either make the improvements impracticable (no benefits can be realized because of other permanent constraints in the system) or more favorable when other replacements can be included as mitigation that provide significant access to habitat.

The 41 structures in South Sammamish have been identified by their station location along the corridor to provide a unique identifier for each drainage path. Figures 1A and 1B shows the trail stationing, location of the 41 structures, and general drainage catchment areas as defined in the King County GIS hydrography layer.

## Screening Steps

Multiple screening steps were performed for each structure: natural systems; stream length and basin area; and conditions for a restorable habitat. In the description of each screening process, conditions for including or excluding a structure from replacement consideration is described. The process is intended to remove structures from further consideration for replacement using multiple lines of evidence so that the focus remains on structures that should be replaced to enhance accessible quality habitat.

## Natural Systems Screen

This screen focuses first on whether or not the existing drainage system has indicators or remnants that a natural stream system was in place prior to basin development and construction of the railroad grade and East Lake Sammamish Parkway (ELSP). If a natural system existed or is still present, the benefits of improved fish passage can be realized and there is potential that restored habitat will be successful. If the conditions did not exist, such as no channels present or a basin of insufficient size to provide appropriate flows and hydrology, the likelihood of a successful habitat improvement is low.

The basin delineations of streams and catchments along the Lake Sammamish shore indicate a typical pattern often found along lakes and shorelines. Typically, a combination of larger named-stream watersheds are found interspersed with very small catchments that drain directly to the lake without forming notable perennial streams or defined drainageways. These small catchments are often grouped together into a single 'drainage basin', in this case the "Monohan Subbasin" (see Figures 1A and 1B). In most existing circumstances, the road and railroad grade collect and concentrate runoff and define the basin, and the existing structures are in place to pass collected drainage to the lake.

The primary indicator of a natural drainage basin used in the desk-top screen is the presence or absence of natural contours that would indicate a stream or drainage channel. The size of the drainage basins not meeting this screen is less than 32 acres for all but one structure; there are, however, some smaller basins showing contours indicating historic drainage. This initial screen includes no evaluation of annual flow regimes for small catchments, although very small and modified basins would be expected to have minimal flow, if any, during the dry season. Only those structures with no apparent historic streams or basins were screened out of further consideration for replacement; the basin size is used as an additional line of evidence that supports the exclusion. Table 1 lists the structures and the presence or absence of natural drainage basin characteristics along with the approximate drainage catchment area to each structure. Structures with no natural drainage basin are shown in red and will be removed from consideration for replacement. Figures 2A-2F show the approximate catchment areas to the trail structures.



Table 1. Structures with Historic Natural Drainage Basin Features

Structure Location Station Number	Natural drainage basin features?	Catchment Area (ac)
218+45	NO	31.7
220+00RT <sup>1</sup>	NO	16.4
224+00	NO	1.8
229+85	YES	6.0
239+60	YES	117.0
241+15	YES	28.2
256+40	YES	42.0
270+00	YES	34.7
276+00	YES	76.2
290+05	YES	135.7
298+50	NO	0.8
308+10	NO	1.3
310+00	YES	3.9
315+90	NO	47.5
316+65	YES	24.7
320+75 <sup>2</sup>	NO	n/a <sup>2</sup>
324+75 <sup>2</sup>	NO	n/a <sup>2</sup>
330+00 <sup>3</sup>	YES	65.4
343+00 <sup>3</sup>	YES	30.6
350+50	NO	1.0
352+25	NO	1.0
356+65	YES	60.6
364+25	YES	8.1
366+75	NO	13.5
370+00	NO	4.2
378+40	YES	1206.3
383+50 <sup>2</sup>	NO	n/a <sup>2</sup>
384+50RT <sup>1,4</sup>	NO	31.9
385+80 <sup>4</sup>	NO	31.9
401+00	YES	128.7
411+10	YES	427.8
426+40	YES	160.1
431+60	YES	27.5
436+10	NO	18.0
441+50	YES	1717.9
450+00	NO	17.4
453+00	NO	7.3
454+50	NO	17.6
456+00	NO	7.8
460+20 <sup>4</sup>	YES	100.3
464+15 <sup>4</sup>	YES	100.3

<sup>1</sup> Structure is in trail section but does not cross under the trail

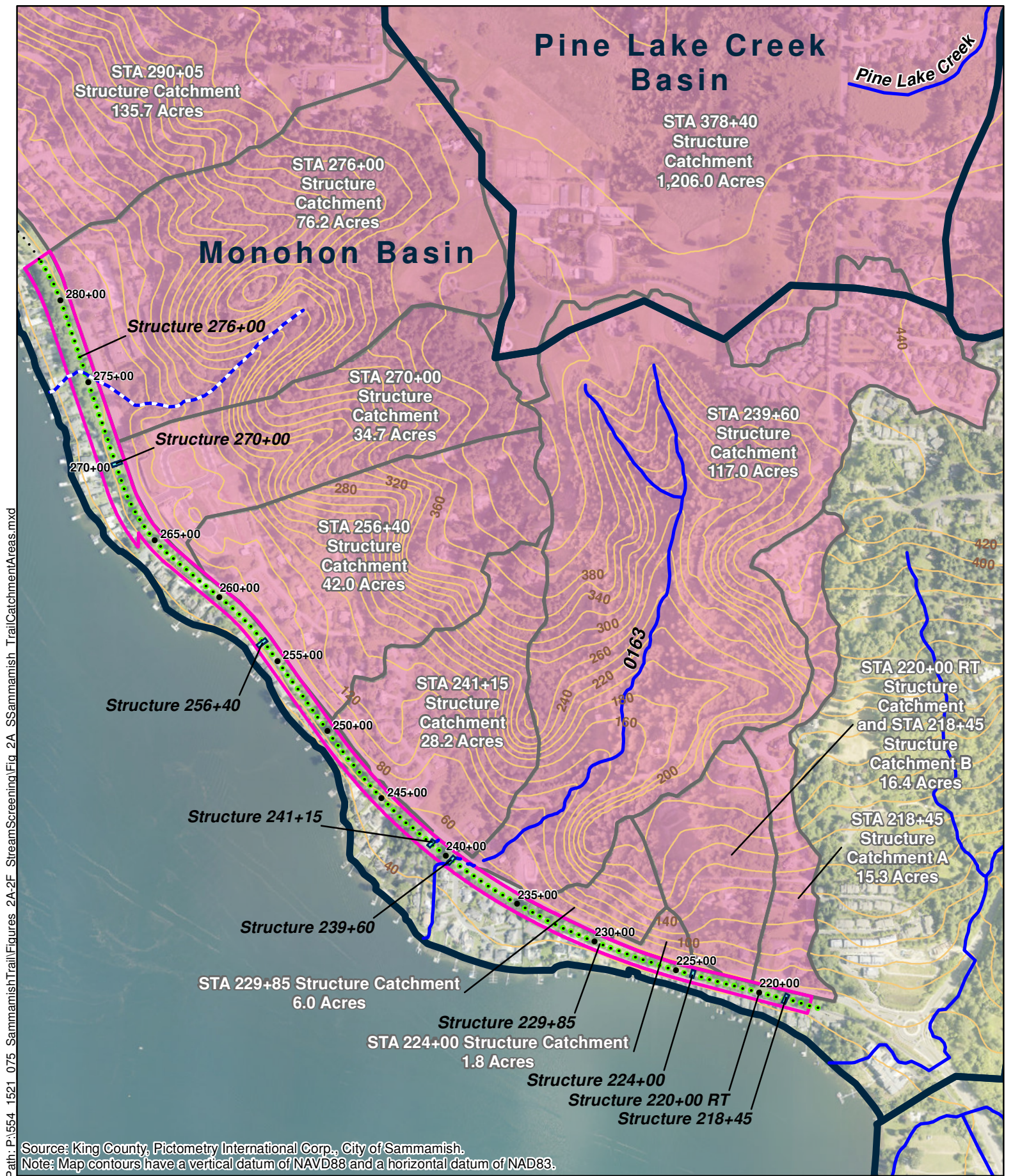
<sup>2</sup> There is no catchment draining to these structures – they serve local drainage only

<sup>3</sup> No structure was found. This structure location is the approximate location of catchment low point to where the catchment drains

<sup>4</sup> This structure drains the same catchment as adjacent structure

Based on this screen alone, 20 of 41 structures are removed from replacement consideration, of which three are located in South Sammamish Segment A.

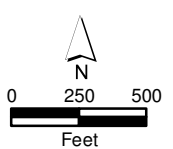




Path: P:\1554\_1521\_075\_SammamishTrail\Figures\_2A-2F\_StreamScreening\Fig\_2A\_Sammamish\_TrailCatchmentAreas.mxd

Source: King County, Pictometry International Corp., City of Sammamish.  
 Note: Map contours have a vertical datum of NAVD88 and a horizontal datum of NAD83.

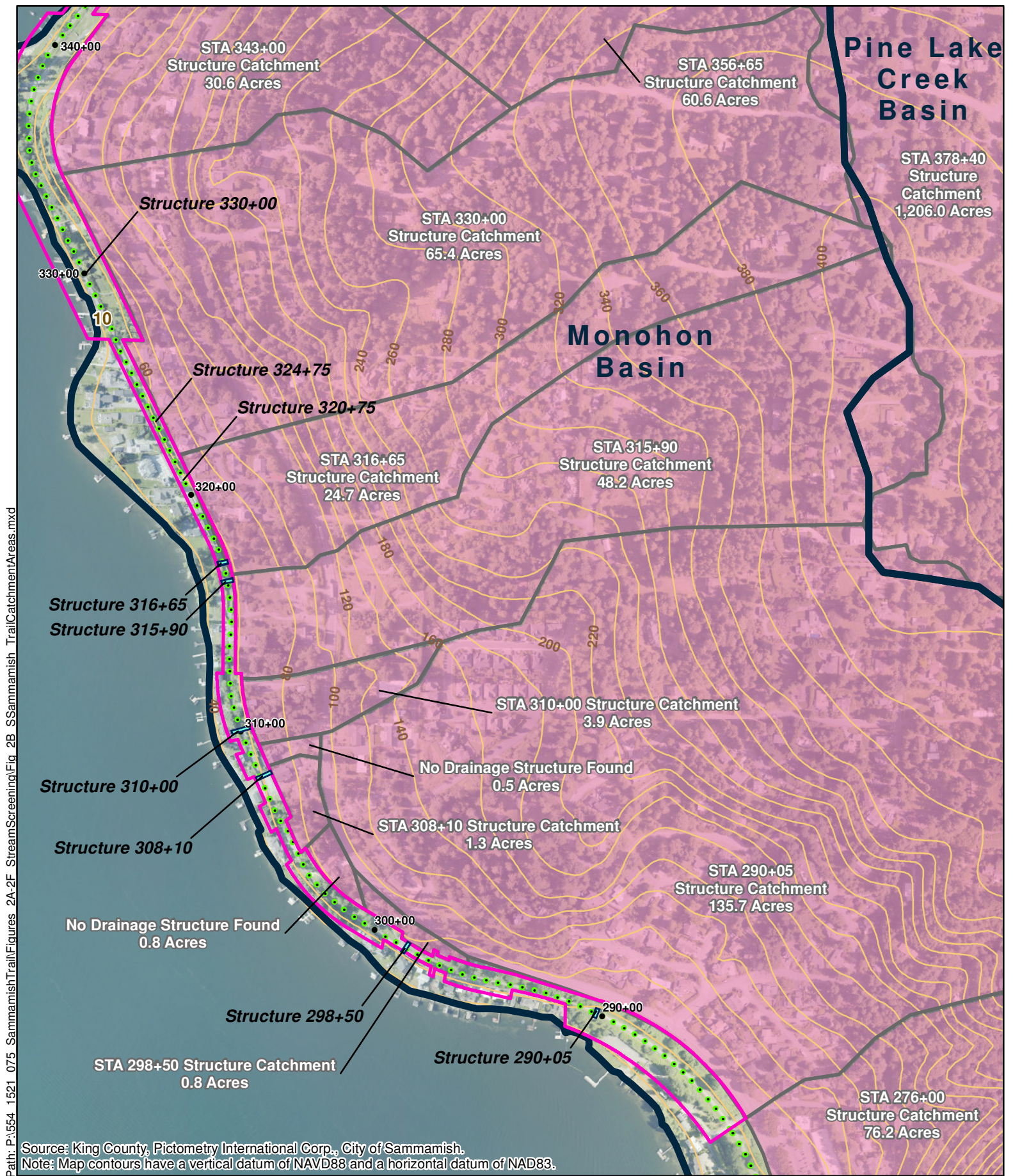
**Parametrix**



- █ South Sammamish Segment A Project Location
- █ Stream Crossing Field-Verified by Parametrix
- █ Stream Crossing Not Found Within Trail Corridor
- City of Sammamish Drainage Basin
- Catchment Area
- █ Contour - 20ft
- █ Drainage Structure
- Proposed Trail Stationing

**Figure 2A**  
**Trail Drainage Structure**  
**Catchment Areas**

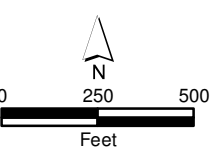




Path: P:\554\_1521\_075\_SammamishTrail\Figures\_2A-2F\_StreamScreening\Fig\_2B\_Sammamish\_Trail\CatchmentAreas.mxd

Source: King County, Pictometry International Corp., City of Sammamish.  
 Note: Map contours have a vertical datum of NAVD88 and a horizontal datum of NAD83.

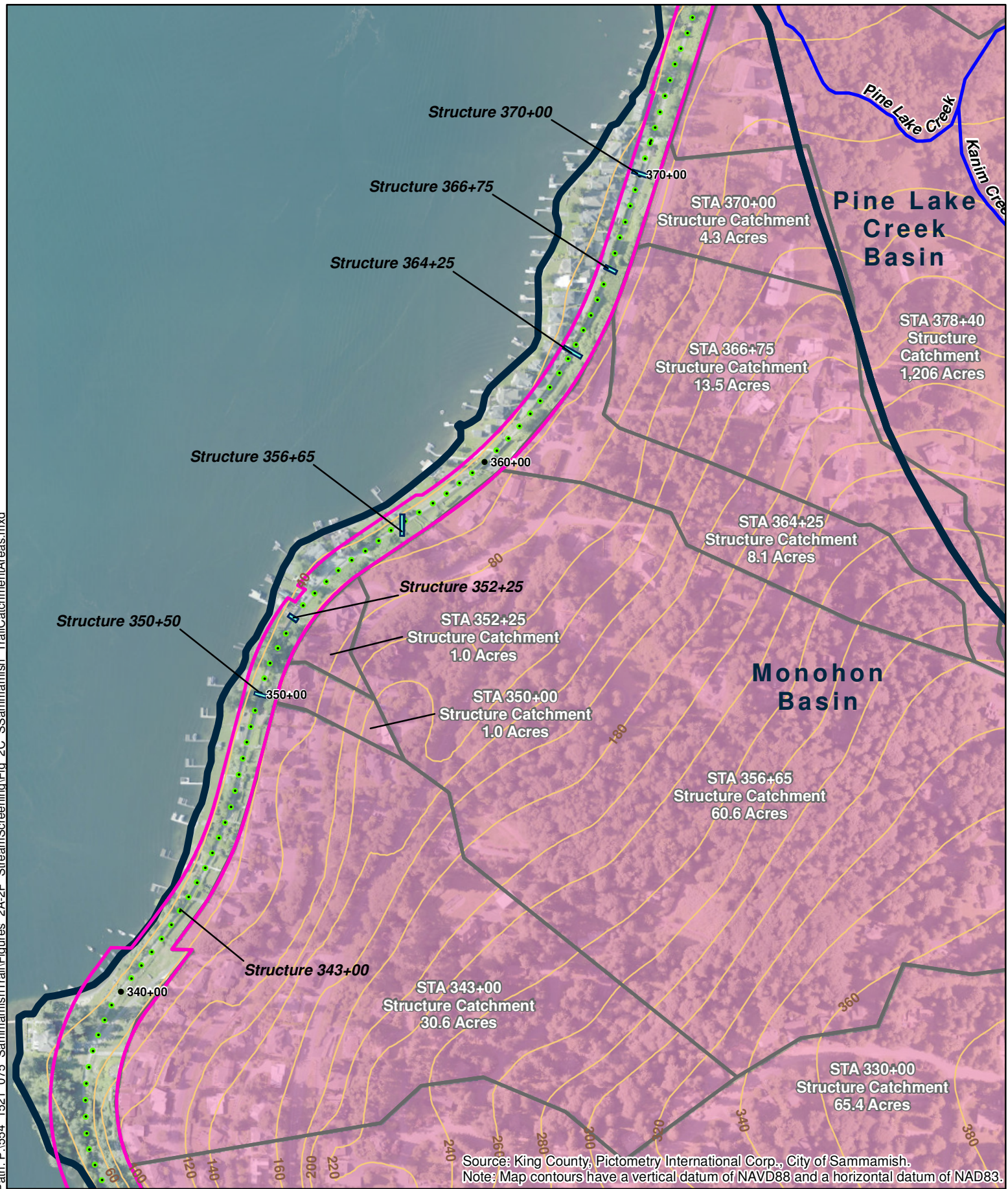
**Parametrix**



- South Sammamish Segment B Project Location
- Stream Crossing Field-Verified by Parametrix
- Stream Crossing Not Found Within Trail Corridor
- City of Sammamish Drainage Basin
- Catchment Area
- Contour - 20ft
- Drainage Structure
- Proposed Trail Stationing

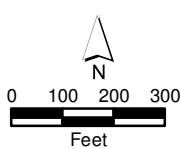
**Figure 2B**  
**Trail Drainage Structure**  
**Catchment Areas**





Source: King County, Pictometry International Corp., City of Sammamish.  
 Note: Map contours have a vertical datum of NAVD88 and a horizontal datum of NAD83.

**Parametrix**

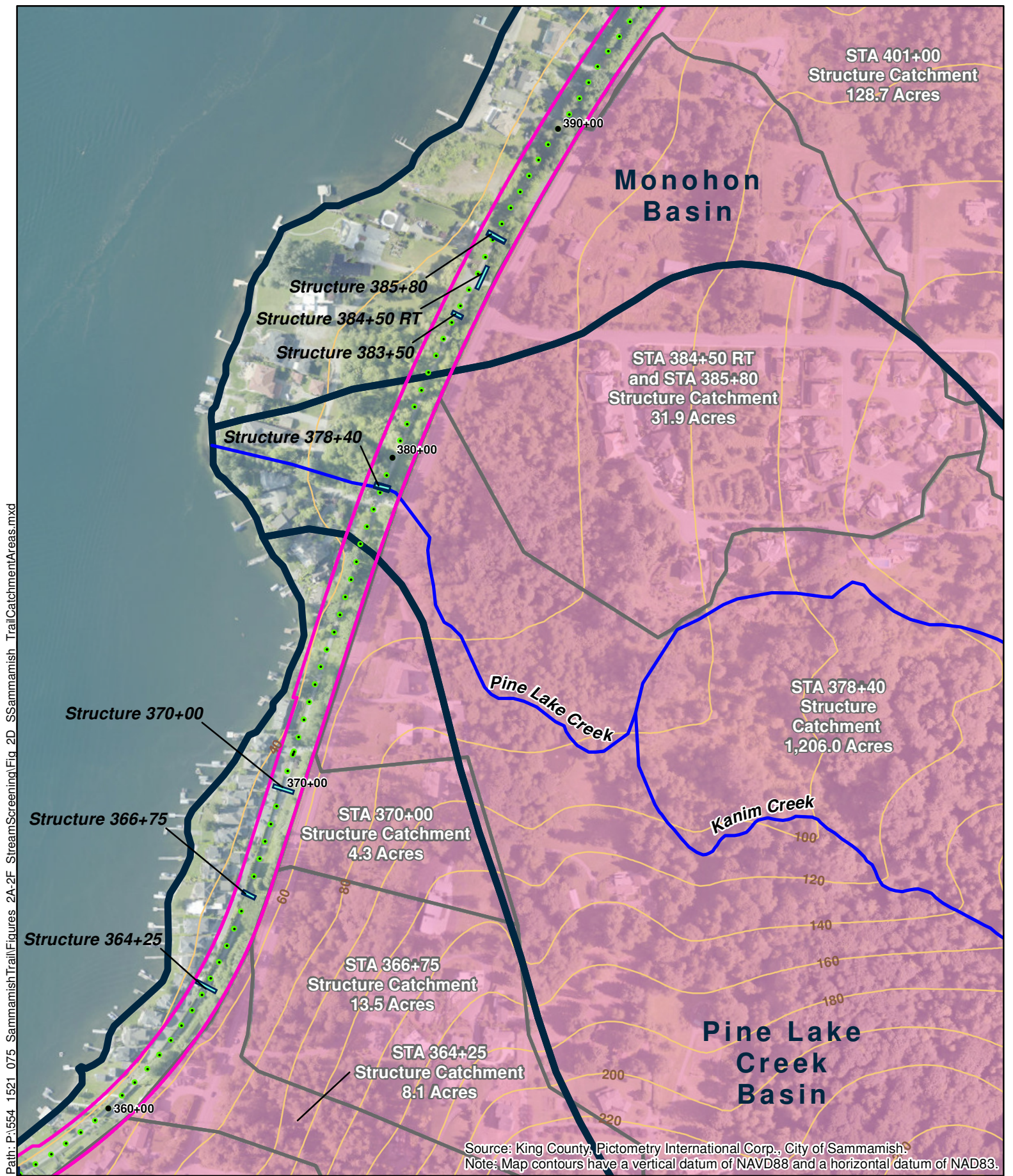


- ▭ South Sammamish Segment A Project Location
- ▬ Stream Crossing Field-Verified by Parametrix
- - - Stream Crossing Not Found Within Trail Corridor
- City of Sammamish Drainage Basin
- Catchment Area
- ▬ Contour - 20ft
- ▬ Drainage Structure



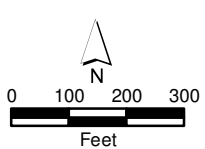
**Figure 2C**  
**Trail Drainage Structure**  
**Catchment Areas**





Path: P:\1554\_1521\_075\_SammamishTrail\Figures\_2A-2F\_StreamScreening\Fig\_2D\_Sammamish\_TrailCatchmentAreas.mxd

**Parametrix**

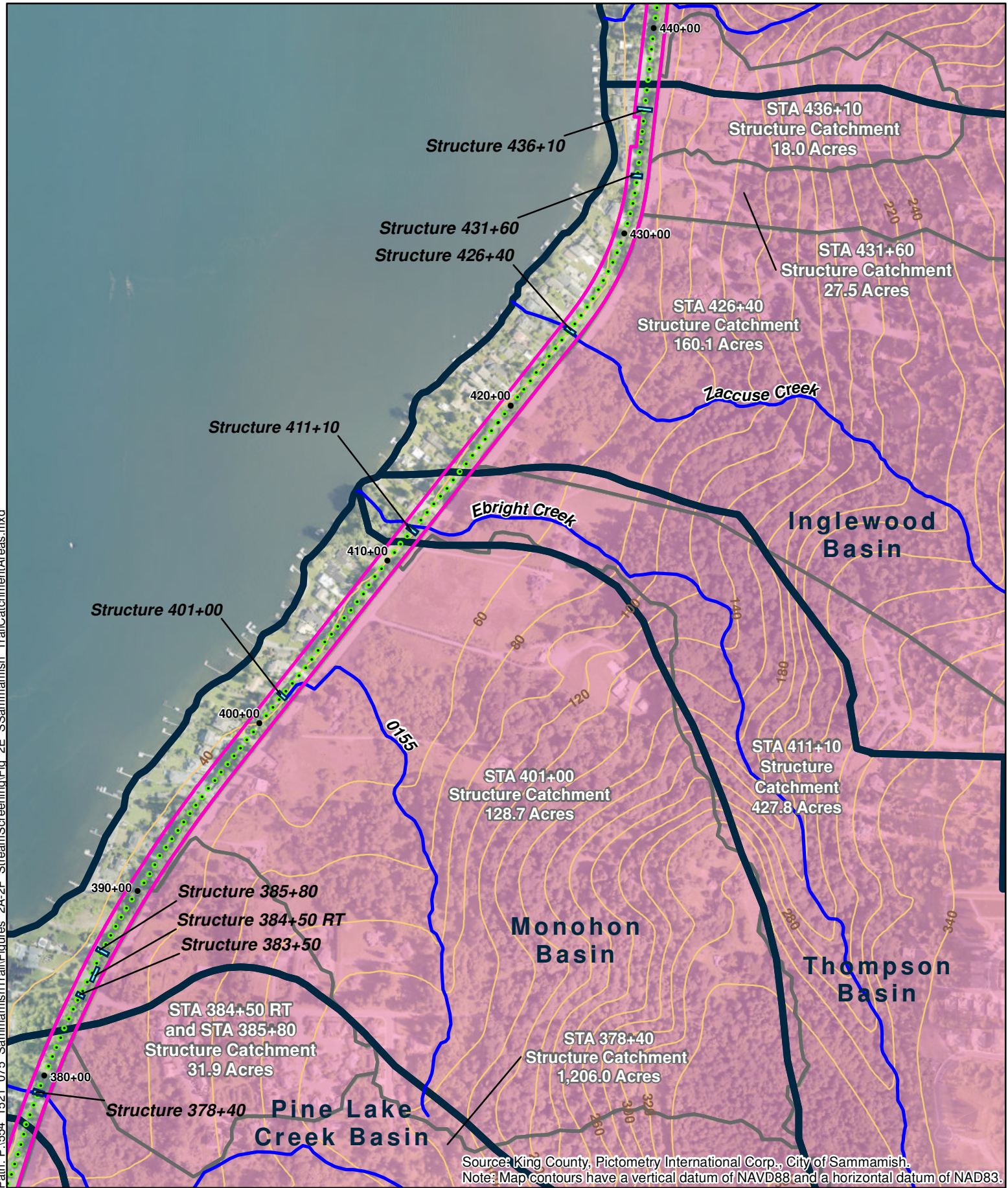


- South Sammamish Segment B Project Location
- Stream Crossing Field-Verified by Parametrix
- Stream Crossing Not Found Within Trail Corridor
- City of Sammamish Drainage Basin
- Catchment Area
- Contour - 20ft
- Drainage Structure
- 480+00
- 485+00
- Proposed Trail Stationing

**Figure 2D**  
**Trail Drainage Structure**  
**Catchment Areas**

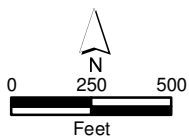


Path: P:\1554\_1521\_075\_SammamishTrail\Figures\_2A-2F\_StreamScreening\Fig\_2E\_Sammamish\_TrailCatchmentAreas.mxd



Source: King County, Pictometry International Corp., City of Sammamish.  
 Note: Map contours have a vertical datum of NAVD88 and a horizontal datum of NAD83.

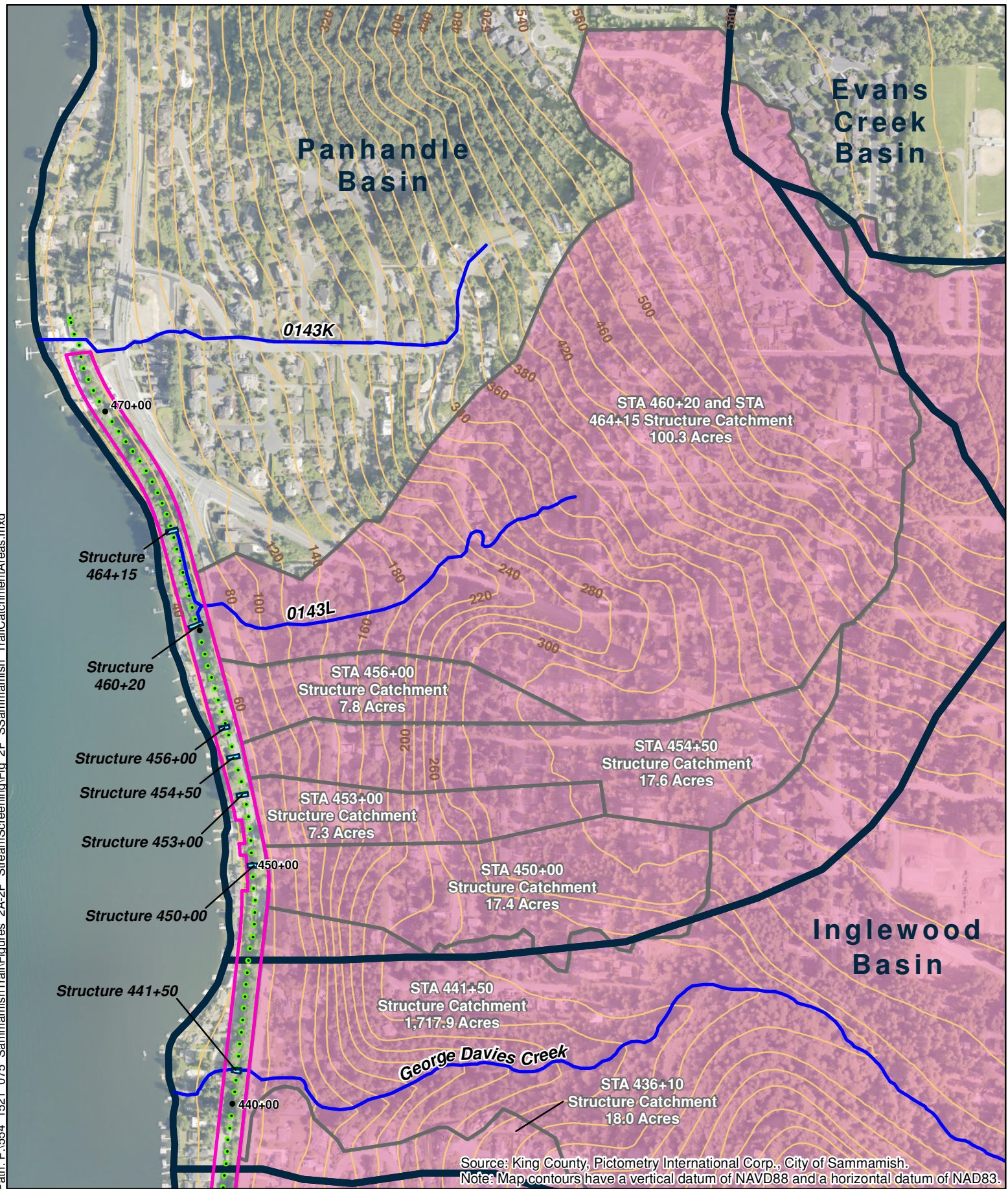
**Parametrix**



- South Sammamish Segment B Project Location
- Stream Crossing Field-Verified by Parametrix
- Stream Crossing Not Found Within Trail Corridor
- City of Sammamish Drainage Basin
- Catchment Area
- Contour - 20ft
- Drainage Structure
- Proposed Trail Stationing

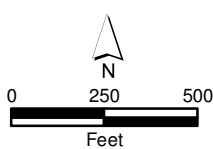
**Figure 2E**  
**Trail Drainage Structure**  
**Catchment Areas**





Source: King County, Pictometry International Corp., City of Sammamish.  
 Note: Map contours have a vertical datum of NAVD88 and a horizontal datum of NAD83.

**Parametrix**



- South Sammamish Segment B Project Location
- Stream Crossing Field-Verified by Parametrix
- Stream Crossing Not Found Within Trail Corridor
- City of Sammamish Drainage Basin
- Catchment Area
- Contour - 20ft
- Drainage Structure
- Proposed Trail Stationing

**Figure 2F**  
**Trail Drainage Structure**  
**Catchment Areas**



The next natural systems evaluation is the presence of the channel in three segments: upstream of the ELSP; between the ELSP and the trail; and between the trail and the lake. This is another indicator of the historic presence of natural or modified channels. In addition to the absence of a channel, a steep channel segment (generally over 16 percent) can effectively make a channel segment inaccessible. Slope was not used as a natural screen in this section but was evaluated for selected structures and screening later in this technical memorandum.

This screen generally indicates whether any potential improvements in the lower reaches, if present, could lead to a connection with upper reaches that may remain in an historic basin. The approximate total length of the drainage channel was measured from the lake to a “channel” upstream of the ELSP; if there is no channel, the length to the ELSP is used. Guidance documents, such as the WDFW Fish Passage Barrier Assessment Manual, uses 200 meters (about 650 feet) to indicate a ‘significant reach of habitat’. Using this approximate length as a screen, channels less than 500 feet in length from the lake to the absence of a channel and with no channel above the ELSP are removed from consideration for replacement. This screen is an indicator that there is virtually no potential for a habitat gain of over 500 feet of stream and often much less. Short reaches in this area are often indicators of local artificial drainage with limited potential that significant upstream natural systems existed before development or construction of the railroad or parkway. Table 2 shows the structure list, the approximate length of each channel segment, and the total length to “no channel”. Twenty structures fail this screen, four of which are in South Sammamish Segment A.

**Table 2. Length of Channel Segments near Each Structure**

Structure location station number	Channel upstream of ELSP?	Approximate length of segment upslope of ELSP (ft)	Approximate length of segment between ELST and ELSP (ft)	Approximate length of segment between Lake and the upstream side of ELST (ft)	Approximate length of reach from Lake Sammamish to no channel (ft)
218+45	YES	220	220	170	610
220+00RT <sup>1</sup>	YES	220	30	n/a	n/a
224+00	NO	120	250	100	470
229+85	YES	530	30	260	820
239+60	YES	5780	140	580	6500
241+15	YES	1250	30	580	1860
256+40	NO	n/a	290	120	410
270+00	NO	n/a	30	270	300
276+00	NO	n/a	40	260	300
290+05	NO	n/a	60	240	300
298+50	NO	n/a	n/a	130	130
308+10	NO	n/a	100	100	200
310+00	NO	n/a	n/a	110	110
315+90	NO	n/a	530	130	660
316+65	YES	910	360	140	1410
320+75	NO	n/a	n/a	n/a	n/a
324+75	NO	n/a	n/a	n/a	n/a
330+00	NO	n/a	n/a	70	70
343+00	NO	n/a	n/a	60	60
350+50	NO	n/a	n/a	80	80

Table 2. Length of Channel Segments near Each Structure (continued)

Structure location station number	Channel upstream of ELSP?	Approximate length of segment upslope of ELSP (ft)	Approximate length of segment between ELST and ELSP (ft)	Approximate length of segment between Lake and the upstream side of ELST (ft)	Approximate length of reach from Lake Sammamish to no channel (ft)
352+25	NO	n/a	n/a	60	60
356+65	YES	850	520	110	1480
364+25	YES	750	160	120	1030
366+75	YES	330	30	210	570
370+00	NO (FV)	n/a	n/a	180	180
378+40	YES	10330	30	490	10850
383+50	NO	n/a	30	600	630
384+50RT	NO (FV)	n/a	140	340	480
385+80	NO (FV)	n/a	100	290	390
401+00	YES	2550	130	290	2970
411+10	YES	11200	60	340	11600
426+40	YES	3320	40	330	3690
431+60	YES	1550	40	260	1850
436+10	NO	n/a	250	270	520
441+50	YES	17300	40	330	17670
450+00	NO (FV)	n/a	90	110	200
453+00	NO (FV)	n/a	30	90	120
454+50	YES	360	40	70	470
456+00	NO (FV)	n/a	20	80	100
460+20 <sup>2</sup>	YES	1750	100	120	1970
464+15 <sup>2</sup>	YES	1750	360	90	2200

FV=Field Verify

<sup>1</sup> This structure is in the same flow path as Structure 218+45, therefore the bottom reach is not included in the channel length

<sup>2</sup> Same upstream channel

## Conditions for Restorable Habitat

The next evaluation considers if conditions are present under reasonable circumstances to restore passage to the trail and beyond. The primary consideration is the potential available length of restorable channel and catchment to provide suitable hydrologic conditions. The basis for the stream length limitation is the WDFW barrier assessment manual, as described above. The basis for the drainage catchment area is WAC 222-16-031, which indicates that a drainage areas must exceed 50 acres to be a Type 3 water, which is a segment of natural waters that has moderate to slight fish use. The next consideration is the location and available pathway for a restored stream channel that could lead to the trail structure. The lack of an existing stream channel or the absence of any drainage way are criteria to eliminate the structure from replacement consideration at this time. Table 3 shows the presence of a channel upstream of ELSP to which a restored system could be connected, length of a demonstrable drainage reach between the lake and ELSP or no channel (whichever is shorter), and catchment area. Channels shorter than 500 feet and with catchments under 50 acres were screened from further consideration and are shown in red.

Table 3. Length of Channel and Catchment Area Screening Data

Structure location station number	Channel upstream of ELSP?	Approximate length of reach from Lake Sammamish to no channel (ft)	Catchment area to trail (ac)
218+45	YES	610	31.8
220+00RT	YES	n/a	16.4
224+00	NO	470	1.8
229+85	YES	820	6.0
239+60	YES	6500	117.0
241+15	YES	1860 <sup>1</sup>	28.2
256+40	NO	410	42.0
270+00	NO (FV)	300	34.7
276+00	NO	300	76.2
290+05	NO	300	135.7
298+50	NO	130	0.8
308+10	NO	200	1.3
310+00	NO	110	3.9
315+90	NO	660	48.5
316+65	YES	1410	24.7
320+75	NO	n/a	n/a
324+75	NO	n/a	n/a
330+00	NO	70	65.4
343+00	NO	60	30.6
350+50	NO	80	1.0
352+25	NO	60	1.0
356+65	YES	1480	60.6
364+25	YES	1030	8.1
366+75	YES	570	13.5
370+00	NO	180	4.3
378+40	YES	10850	1206.0
383+50	NO	630	n/a
384+50RT	NO	480	31.9
385+80	NO	390	31.9
401+00	YES	2970	128.7
411+10	YES	11600	427.8
426+40	YES	3690	160.1
431+60	YES	1850	27.5
436+10	NO	520	18.0
441+50	YES	17670	1717.9
450+00	NO (FV)	200	17.4
453+00	NO (FV)	120	7.3
454+50	YES	470	17.6
456+00	NO (FV)	100	7.8
460+20	YES	1970	100.3
464+15	YES	2200	100.3

<sup>1</sup> Lower 580 feet is shared with 239+60

Table 4 lists existing reach conditions that have adequate available area for a meaningful and successful stream or natural systems restoration. For example, is the corridor between houses available for open channel construction or is there space for a meaningful channel and connected riparian area. Positive results in these areas would not represent proposals for the County to make these improvements, but rather identify areas where, if the County upgraded the structure under the ELST, others could come in and make improvements to create habitat. Structures in red are those where any of the built environment criteria are not suitable for restoration and there is no channel upstream of ELSP. Also, structures with gradient barriers (three structures were more closely evaluated for gradient steeper than 16 percent – 316+65, 356+65, and 431+60), or with an unsuitable section and less than 20 acre catchment were removed. 32 structures were removed using this screen, including six in South Sammamish Segment A.

**Table 4. Structures Where Conditions are Suitable for Restoration**

Structure location station number	Channel upstream of ELSP?	Built environment supports potential restoration upstream of ELSP?	Built environment supports potential restoration between ELST and ELSP?	Built environment supports potential restoration downstream of ELST?	Approximate length of reach from Lake Sammamish to no channel (ft)	Catchment area to trail (ac)
218+45	YES	YES	YES	YES	610	31.8
220+00RT	YES	YES	YES	YES	n/a	16.4
224+00	NO	NO	YES	NO (in pipe)	470	1.8
229+85	YES	YES	YES	NO (in pipe)	820	6.0
239+60	YES	YES	YES	YES	6500	117.0
241+15	YES	YES	YES	NO (not found)	1860	28.2
256+40	NO	NO	YES	NO (piped/conc channel)	410	42.0
270+00	NO (FV)	NO	NO	NO (not found)	300	34.7
276+00	NO	NO	NO (in pipe)	NO (in pipe)	300	76.2
290+05	NO	NO	NO	NO (not found)	300	135.7
298+50	NO	NO	NO	NO (in pipe)	130	0.8
308+10	NO	NO	NO (storm sewer)	YES	200	1.3
310+00	NO	NO	NO (in pipe)	NO (piped under house)	110	3.9
315+90	NO	NO	NO (not 2')	YES	660	48.2
316+65	YES	YES	NO (gradient 20%+)	YES	1410	24.7
320+75	NO	NO	NO	NO (no channel to lake)	n/a	n/a
324+75	NO	NO	NO	NO (no channel to lake)	n/a	n/a
330+00	NO	NO	NO (no outlet)	NO (no channel to lake)	70	65.4
343+00	NO	NO	NO (no outlet)	NO (no channel to lake)	60	30.6
350+50	NO	NO	NO (not 2')	YES	80	1.0

Table 4. Structures Where Conditions are Suitable for Restoration (continued)

Structure location station number	Channel upstream of ELSP?	Built environment supports potential restoration upstream of ELSP?	Built environment supports potential restoration between ELST and ELSP?	Built environment supports potential restoration downstream of ELST?	Approximate length of reach from Lake Sammamish to no channel (ft)	Catchment area to trail (ac)
352+25	NO	NO	NO (not 2') No (gradient 30%+)	YES	60	1.0
356+65	YES	YES	YES	YES	1480	60.6
364+25	YES	YES	YES	NO (piped)	1030	8.1
366+75	YES	YES	YES	NO (partial pipe)	570	13.5
370+00	NO	NO	YES	NO (piped)	180	4.3
378+40	YES	YES	YES	YES	10850	1206.0
383+50	NO	NO	YES	YES	630	n/a
384+50RT	NO	NO	YES	NO (partial pipe)	480	31.9
385+80	NO	NO	YES	NO (partial pipe)	390	31.9
401+00	YES	YES	YES	NO (piped)	2970	128.7
411+10	YES	YES	YES	YES	11600	427.8
426+40	YES	YES	YES	YES	3690	160.1
431+60	YES	YES (FV)	NO (gradient 19%+)	YES	1850	27.5
436+10	NO	NO	YES	NO (piped)	520	18.0
441+50	YES	YES	YES	YES	17670	1717.9
450+00	NO (FV)	NO	YES	NO (partial pipe)	200	17.4
453+00	NO (FV)	NO	NO (pipe)	YES	120	7.3
454+50	YES	YES	NO (pipe)	YES	470	17.6
456+00	NO (FV)	NO	YES	YES	100	7.8
460+20	YES	YES	NO (gradient 20%+)	NO (gradient )	1970	100.3
464+15	YES	YES	YES	YES	2200	100.3

### Summary of Results

Most of the culverts in the screening process were removed due to multiple issues, which is reflective of the heavily modified conditions and the evidence that many of these drainage paths did not historically provide habitat upstream of the lake’s edge beyond the location of the parkway or railroad grade. A review summary of all of the screening steps is shown in Table 5. Structures in red do not pass that screen.



Table 5. Summary of Structure Screens

Structures in the South Sammamish Segment	Structures removed by the natural basin screen (Table 1)	Structures with no channel upstream of ELSP and less than 500 feet in length (Table 2)	Structures with catchments less than 50 acres and less than 500 feet of channel (Table 3)	Structures with poor suitability for restoration (Table 4)	Structures remaining	Stream name or identifier
218+45	218+45	218+45	218+45	218+45		
220+00RT	220+00RT	220+00RT <sup>1</sup>	220+00RT	220+00RT		
224+00	224+00	224+00	224+00	224+00		
229+85	229+85	229+85	229+85	229+85		
239+60	239+60	239+60	239+60	239+60	239+60	0163 N & S
241+15	241+15	241+15	241+15	241+15	241+15	0163 N & S
256+40	256+40	256+40	256+40	256+40		
270+00	270+00	270+00	270+00	270+00		
276+00	276+00	276+00	276+00	276+00		
290+05	290+05	290+05	290+05	290+05		
298+50	298+50	298+50	298+50	298+50		
308+10	308+10	308+10	308+10	308+10		
310+00	310+00	310+00	310+00	310+00		
315+90	315+90	315+90	315+90	315+90		
316+65	316+65	316+65	316+65	316+65		
320+75	320+75	320+75	320+75	320+75		
324+75	324+75	324+75	324+75	324+75		
330+00	330+00	330+00	330+00	330+00		
343+00	343+00	343+00	343+00	343+00		
350+50	350+50	350+50	350+50	350+50		
352+25	352+25	352+25	352+25	352+25		
356+65	356+65	356+65	356+65	356+65		
364+25	364+25	364+25	364+25	364+25		
366+75	366+75	366+75	366+75	366+75		
370+00	370+00	370+00	370+00	370+00		
378+40	378+40	378+40	378+40	378+40	378+40	Pine Lake Creek
383+50	383+50	383+50	383+50	383+50		
384+50RT	384+50RT	384+50RT	384+50RT	384+50RT		
385+80	385+80	385+80	385+80	385+80		
401+00	401+00	401+00	401+00	401+00	401+00	0155
411+10	411+10	411+10	411+10	411+10	411+10	Ebright Creek
426+40	426+40	426+40	426+40	426+40	426+40	Zaccuse Creek
431+60	431+60	431+60	431+60	431+60		
436+10	436+10	436+10	436+10	436+10		
441+50	441+50	441+50	441+50	441+50	441+50	George Davis Cr
450+00	450+00	450+00	450+00	450+00		
453+00	453+00	453+00	453+00	453+00		
454+50	454+50	454+50	454+50	454+50		
456+00	456+00	456+00	456+00	456+00		
460+20	460+20	460+20	460+20	460+20		
464+15	464+15	464+15	464+15	464+15	464+15	0143L

Eight structures pass all of the screens (see Table 5) and are to be further evaluated to confirm the replacement approach. The WDNR stream typing maps were reviewed as a cross reference of the screening process. The stream types for the structures passing the screens is shown on Table 6, which shows that six of the eight structures are Type F, one is Type N, and one is not typed or shown on the maps. There are no Type F streams in the Segment A corridor that are not included in this list.

**Table 6. Summary of Structures and Proposed Status**

Structures passing all screens	Stream name	WDNR stream typing	Proposal (reason)	Comments
239+60	0163S	Type F	Not replaced (no habitat gain without other replacements outside of trail corridor); additional culverts replaced at Zaccuse and Pine Lake Creeks	Channel combines immediately downstream of trail; barrier immediately upstream
241+15	0163N	Type N	Not replaced (no habitat gain without other replacements outside of trail corridor); additional culverts replaced at Zaccuse and Pine Lake Creeks	Channel combines immediately downstream of trail; channel in culvert immediately downstream of trail
378+40	Pine Lake Creek	Type F	Replace (pass screens, named, Type F); Additional structure to be replaced outside of trail corridor	Two culverts proposed will provide complementary benefits for comprehensive habitat gain
401+00	Stream 155	Type F	Replace (pass screens, named, Type F)	Downstream reach to lake is in a pipe that must be replaced to gain benefit
411+10	Ebright Creek	Type F	Replace (pass screens, named, Type F)	
426+40	Zaccuse Creek	Type F	Replace (pass screens, named, Type F); Additional structure to be replaced outside of trail corridor	Two culverts proposed will provide complementary benefits for comprehensive habitat gain
441+50	George Davis Creek	Type F	Replace (pass screens, named, Type F)	
464+15	Stream 143L	not typed	Replace (pass screens)	

The data in the screens provide a meaningful objective analysis of structure replacement needs and potential. This approach and the results support the County’s approach to removal of passage barriers in the South Sammamish Segment.

DRAFT

Appendix E  
Operation and Maintenance Requirements





<b>NO. 2 – INFILTRATION FACILITIES</b>			
<b>Maintenance Component</b>	<b>Defect or Problem</b>	<b>Conditions When Maintenance Is Needed</b>	<b>Results Expected When Maintenance Is Performed</b>
Site	Trash and debris	Any trash and debris which exceed 1 cubic foot per 1,000 square feet (this is about equal to the amount of trash it would take to fill up one standard size office garbage can). In general, there should be no visual evidence of dumping.	Trash and debris cleared from site.
	Noxious weeds	Any noxious or nuisance vegetation which may constitute a hazard to County personnel or the public.	Noxious and nuisance vegetation removed according to applicable regulations. No danger of noxious vegetation where County personnel or the public might normally be.
	Contaminants and pollution	Any evidence of contaminants or pollution such as oil, gasoline, concrete slurries or paint.	Materials removed and disposed of according to applicable regulations. Source control BMPs implemented if appropriate. No contaminants present other than a surface oil film.
	Grass/groundcover	Grass or groundcover exceeds 18 inches in height.	Grass or groundcover mowed to a height no greater than 6 inches.
Infiltration Pond, Top or Side Slopes of Dam, Berm or Embankment	Rodent holes	Any evidence of rodent holes if facility is acting as a dam or berm, or any evidence of water piping through dam or berm via rodent holes.	Rodents removed or destroyed and dam or berm repaired.
	Tree growth	Tree growth threatens integrity of dams, berms or slopes, does not allow maintenance access, or interferes with maintenance activity. If trees are not a threat to dam, berm, or embankment integrity or not interfering with access or maintenance, they do not need to be removed.	Trees do not hinder facility performance or maintenance activities.
	Erosion	Eroded damage over 2 inches deep where cause of damage is still present or where there is potential for continued erosion. Any erosion observed on a compacted slope.	Slopes stabilized using appropriate erosion control measures. If erosion is occurring on compacted slope, a licensed civil engineer should be consulted to resolve source of erosion.
	Settlement	Any part of a dam, berm or embankment that has settled 4 inches lower than the design elevation.	Top or side slope restored to design dimensions. If settlement is significant, a licensed civil engineer should be consulted to determine the cause of the settlement.
Infiltration Pond, Tank, Vault, Trench, or Small Basin Storage Area	Sediment accumulation	If two inches or more sediment is present or a percolation test indicates facility is working at or less than 90% of design.	Facility infiltrates as designed.
	Liner damaged (If Applicable)	Liner is visible or pond does not hold water as designed.	Liner repaired or replaced.
Infiltration Tank Structure	Plugged air vent	Any blockage of the vent.	Tank or vault freely vents.
	Tank bent out of shape	Any part of tank/pipe is bent out of shape more than 10% of its design shape.	Tank repaired or replaced to design.
	Gaps between sections, damaged joints or cracks or tears in wall	A gap wider than ½-inch at the joint of any tank sections or any evidence of soil particles entering the tank at a joint or through a wall.	No water or soil entering tank through joints or walls.
Infiltration Vault Structure	Damage to wall, frame, bottom, and/or top slab	Cracks wider than ½-inch, any evidence of soil entering the structure through cracks or qualified inspection personnel determines that the vault is not structurally sound.	Vault is sealed and structurally sound.



<b>NO. 2 – INFILTRATION FACILITIES</b>			
<b>Maintenance Component</b>	<b>Defect or Problem</b>	<b>Conditions When Maintenance Is Needed</b>	<b>Results Expected When Maintenance Is Performed</b>
Inlet/Outlet Pipes	Sediment accumulation	Sediment filling 20% or more of the pipe.	Inlet/outlet pipes clear of sediment.
	Trash and debris	Trash and debris accumulated in inlet/outlet pipes (includes floatables and non-floatables).	No trash or debris in pipes.
	Damaged	Cracks wider than ½-inch at the joint of the inlet/outlet pipes or any evidence of soil entering at the joints of the inlet/outlet pipes.	No cracks more than ¼-inch wide at the joint of the inlet/outlet pipe.
Access Manhole	Cover/lid not in place	Cover/lid is missing or only partially in place. <b>Any open manhole requires immediate maintenance.</b>	Manhole access covered.
	Locking mechanism not working	Mechanism cannot be opened by one maintenance person with proper tools. Bolts cannot be seated. Self-locking cover/lid does not work.	Mechanism opens with proper tools.
	Cover/lid difficult to remove	One maintenance person cannot remove cover/lid after applying 80 lbs of lift.	Cover/lid can be removed and reinstalled by one maintenance person.
	Ladder rungs unsafe	Missing rungs, misalignment, rust, or cracks.	Ladder meets design standards. Allows maintenance person safe access.
Large access doors/plate	Damaged or difficult to open	Large access doors or plates cannot be opened/removed using normal equipment.	Replace or repair access door so it can be opened as designed.
	Gaps, doesn't cover completely	Large access doors not flat and/or access opening not completely covered.	Doors close flat and covers access opening completely.
	Lifting Rings missing, rusted	Lifting rings not capable of lifting weight of door or plate.	Lifting rings sufficient to lift or remove door or plate.
Infiltration Pond, Tank, Vault, Trench, or Small Basin Filter Bags	Plugged	Filter bag more than ½ full.	Replace filter bag or redesign system.
Infiltration Pond, Tank, Vault, Trench, or Small Basin Pre-settling Ponds and Vaults	Sediment accumulation	6" or more of sediment has accumulated.	Pre-settling occurs as designed
Infiltration Pond, Rock Filter	Plugged	High water level on upstream side of filter remains for extended period of time or little or no water flows through filter during heavy rain storms.	Rock filter replaced evaluate need for filter and remove if not necessary.
Infiltration Pond Emergency Overflow Spillway	Rock missing	Only one layer of rock exists above native soil in area five square feet or larger, or any exposure of native soil at the top of out flow path of spillway. Rip-rap on inside slopes need not be replaced.	Spillway restored to design standards.
	Tree growth	Tree growth impedes flow or threatens stability of spillway.	Trees removed.

<b>NO. 4 – CONTROL STRUCTURE/FLOW RESTRICTOR</b>			
<b>Maintenance Component</b>	<b>Defect or Problem</b>	<b>Condition When Maintenance is Needed</b>	<b>Results Expected When Maintenance is Performed</b>
Structure	Trash and debris	Trash or debris of more than ½ cubic foot which is located immediately in front of the structure opening or is blocking capacity of the structure by more than 10%.	No Trash or debris blocking or potentially blocking entrance to structure.
		Trash or debris in the structure that exceeds 1/3 the depth from the bottom of basin to invert the lowest pipe into or out of the basin.	No trash or debris in the structure.
		Deposits of garbage exceeding 1 cubic foot in volume.	No condition present which would attract or support the breeding of insects or rodents.
	Sediment	Sediment exceeds 60% of the depth from the bottom of the structure to the invert of the lowest pipe into or out of the structure or the bottom of the FROP-T section or is within 6 inches of the invert of the lowest pipe into or out of the structure or the bottom of the FROP-T section.	Sump of structure contains no sediment.
	Damage to frame and/or top slab	Corner of frame extends more than ¾ inch past curb face into the street (If applicable).	Frame is even with curb.
		Top slab has holes larger than 2 square inches or cracks wider than ¼ inch.	Top slab is free of holes and cracks.
		Frame not sitting flush on top slab, i.e., separation of more than ¾ inch of the frame from the top slab.	Frame is sitting flush on top slab.
	Cracks in walls or bottom	Cracks wider than ½ inch and longer than 3 feet, any evidence of soil particles entering structure through cracks, or maintenance person judges that structure is unsound.	Structure is sealed and structurally sound.
		Cracks wider than ½ inch and longer than 1 foot at the joint of any inlet/outlet pipe or any evidence of soil particles entering structure through cracks.	No cracks more than ¼ inch wide at the joint of inlet/outlet pipe.
	Settlement/misalignment	Structure has settled more than 1 inch or has rotated more than 2 inches out of alignment.	Basin replaced or repaired to design standards.
	Damaged pipe joints	Cracks wider than ½-inch at the joint of the inlet/outlet pipes or any evidence of soil entering the structure at the joint of the inlet/outlet pipes.	No cracks more than ¼-inch wide at the joint of inlet/outlet pipes.
	Contaminants and pollution	Any evidence of contaminants or pollution such as oil, gasoline, concrete slurries or paint.	Materials removed and disposed of according to applicable regulations. Source control BMPs implemented if appropriate. No contaminants present other than a surface oil film.
	Ladder rungs missing or unsafe	Ladder is unsafe due to missing rungs, misalignment, rust, cracks, or sharp edges.	Ladder meets design standards and allows maintenance person safe access.
FROP-T Section	Damage	T section is not securely attached to structure wall and outlet pipe structure should support at least 1,000 lbs of up or down pressure.	T section securely attached to wall and outlet pipe.
		Structure is not in upright position (allow up to 10% from plumb).	Structure in correct position.
		Connections to outlet pipe are not watertight or show signs of deteriorated grout.	Connections to outlet pipe are water tight; structure repaired or replaced and works as designed.
		Any holes—other than designed holes—in the structure.	Structure has no holes other than designed holes.
Cleanout Gate	Damaged or missing	Cleanout gate is missing.	Replace cleanout gate.

<b>NO. 4 – CONTROL STRUCTURE/FLOW RESTRICTOR</b>			
<b>Maintenance Component</b>	<b>Defect or Problem</b>	<b>Condition When Maintenance is Needed</b>	<b>Results Expected When Maintenance is Performed</b>
		Cleanout gate is not watertight.	Gate is watertight and works as designed.
		Gate cannot be moved up and down by one maintenance person.	Gate moves up and down easily and is watertight.
		Chain/rod leading to gate is missing or damaged.	Chain is in place and works as designed.
Orifice Plate	Damaged or missing	Control device is not working properly due to missing, out of place, or bent orifice plate.	Plate is in place and works as designed.
	Obstructions	Any trash, debris, sediment, or vegetation blocking the plate.	Plate is free of all obstructions and works as designed.
Overflow Pipe	Obstructions	Any trash or debris blocking (or having the potential of blocking) the overflow pipe.	Pipe is free of all obstructions and works as designed.
	Deformed or damaged lip	Lip of overflow pipe is bent or deformed.	Overflow pipe does not allow overflow at an elevation lower than design
Inlet/Outlet Pipe	Sediment accumulation	Sediment filling 20% or more of the pipe.	Inlet/outlet pipes clear of sediment.
	Trash and debris	Trash and debris accumulated in inlet/outlet pipes (includes floatables and non-floatables).	No trash or debris in pipes.
	Damaged	Cracks wider than ½-inch at the joint of the inlet/outlet pipes or any evidence of soil entering at the joints of the inlet/outlet pipes.	No cracks more than ¼-inch wide at the joint of the inlet/outlet pipe.
Metal Grates (If Applicable)	Unsafe grate opening	Grate with opening wider than 7/8 inch.	Grate opening meets design standards.
	Trash and debris	Trash and debris that is blocking more than 20% of grate surface.	Grate free of trash and debris. footnote to guidelines for disposal
	Damaged or missing	Grate missing or broken member(s) of the grate.	Grate is in place and meets design standards.
Manhole Cover/Lid	Cover/lid not in place	Cover/lid is missing or only partially in place. <b>Any open structure requires urgent maintenance.</b>	Cover/lid protects opening to structure.
	Locking mechanism Not Working	Mechanism cannot be opened by one maintenance person with proper tools. Bolts cannot be seated. Self-locking cover/lid does not work.	Mechanism opens with proper tools.
	Cover/lid difficult to Remove	One maintenance person cannot remove cover/lid after applying 80 lbs. of lift.	Cover/lid can be removed and reinstalled by one maintenance person.

<b>NO. 5 – CATCH BASINS AND MANHOLES</b>				
<b>Maintenance Component</b>	<b>Defect or Problem</b>	<b>Condition When Maintenance is Needed</b>	<b>Results Expected When Maintenance is Performed</b>	
Structure	Sediment	Sediment exceeds 60% of the depth from the bottom of the catch basin to the invert of the lowest pipe into or out of the catch basin or is within 6 inches of the invert of the lowest pipe into or out of the catch basin.	Sump of catch basin contains no sediment.	
	Trash and debris	Trash or debris of more than ½ cubic foot which is located immediately in front of the catch basin opening or is blocking capacity of the catch basin by more than 10%.	No Trash or debris blocking or potentially blocking entrance to catch basin.	
		Trash or debris in the catch basin that exceeds 1/3 the depth from the bottom of basin to invert the lowest pipe into or out of the basin.	No trash or debris in the catch basin.	
		Dead animals or vegetation that could generate odors that could cause complaints or dangerous gases (e.g., methane).	No dead animals or vegetation present within catch basin.	
		Deposits of garbage exceeding 1 cubic foot in volume.	No condition present which would attract or support the breeding of insects or rodents.	
		Damage to frame and/or top slab	Corner of frame extends more than ¾ inch past curb face into the street (If applicable).	Frame is even with curb.
	Cracks in walls or bottom	Top slab has holes larger than 2 square inches or cracks wider than ¼ inch.	Top slab is free of holes and cracks.	
		Frame not sitting flush on top slab, i.e., separation of more than ¾ inch of the frame from the top slab.	Frame is sitting flush on top slab.	
		Cracks wider than ½ inch and longer than 3 feet, any evidence of soil particles entering catch basin through cracks, or maintenance person judges that catch basin is unsound.	Catch basin is sealed and structurally sound.	
	Settlement/ misalignment	Cracks wider than ½ inch and longer than 1 foot at the joint of any inlet/outlet pipe or any evidence of soil particles entering catch basin through cracks.	No cracks more than 1/4 inch wide at the joint of inlet/outlet pipe.	
		Catch basin has settled more than 1 inch or has rotated more than 2 inches out of alignment.	Basin replaced or repaired to design standards.	
	Damaged pipe joints	Cracks wider than ½-inch at the joint of the inlet/outlet pipes or any evidence of soil entering the catch basin at the joint of the inlet/outlet pipes.	No cracks more than ¼-inch wide at the joint of inlet/outlet pipes.	
	Contaminants and pollution	Any evidence of contaminants or pollution such as oil, gasoline, concrete slurries or paint.	Materials removed and disposed of according to applicable regulations. Source control BMPs implemented if appropriate. No contaminants present other than a surface oil film.	
	Inlet/Outlet Pipe	Sediment accumulation	Sediment filling 20% or more of the pipe.	Inlet/outlet pipes clear of sediment.
		Trash and debris	Trash and debris accumulated in inlet/outlet pipes (includes floatables and non-floatables).	No trash or debris in pipes.
Damaged		Cracks wider than ½-inch at the joint of the inlet/outlet pipes or any evidence of soil entering at the joints of the inlet/outlet pipes.	No cracks more than ¼-inch wide at the joint of the inlet/outlet pipe.	

<b>NO. 5 – CATCH BASINS AND MANHOLES</b>			
<b>Maintenance Component</b>	<b>Defect or Problem</b>	<b>Condition When Maintenance is Needed</b>	<b>Results Expected When Maintenance is Performed</b>
Metal Grates (Catch Basins)	Unsafe grate opening	Grate with opening wider than $\frac{7}{8}$ inch.	Grate opening meets design standards.
	Trash and debris	Trash and debris that is blocking more than 20% of grate surface.	Grate free of trash and debris. footnote to guidelines for disposal
	Damaged or missing	Grate missing or broken member(s) of the grate. <b>Any open structure requires urgent maintenance.</b>	Grate is in place and meets design standards.
Manhole Cover/Lid	Cover/lid not in place	Cover/lid is missing or only partially in place. <b>Any open structure requires urgent maintenance.</b>	Cover/lid protects opening to structure.
	Locking mechanism Not Working	Mechanism cannot be opened by one maintenance person with proper tools. Bolts cannot be seated. Self-locking cover/lid does not work.	Mechanism opens with proper tools.
	Cover/lid difficult to Remove	One maintenance person cannot remove cover/lid after applying 80 lbs. of lift.	Cover/lid can be removed and reinstalled by one maintenance person.



<b>NO. 6 – CONVEYANCE PIPES AND DITCHES</b>			
<b>Maintenance Component</b>	<b>Defect or Problem</b>	<b>Conditions When Maintenance is Needed</b>	<b>Results Expected When Maintenance is Performed</b>
Pipes	Sediment & debris accumulation	Accumulated sediment or debris that exceeds 20% of the diameter of the pipe.	Water flows freely through pipes.
	Vegetation/roots	Vegetation/roots that reduce free movement of water through pipes.	Water flows freely through pipes.
	Contaminants and pollution	Any evidence of contaminants or pollution such as oil, gasoline, concrete slurries or paint.	Materials removed and disposed of according to applicable regulations. Source control BMPs implemented if appropriate. No contaminants present other than a surface oil film.
	Damage to protective coating or corrosion	Protective coating is damaged; rust or corrosion is weakening the structural integrity of any part of pipe.	Pipe repaired or replaced.
	Damaged	Any dent that decreases the cross section area of pipe by more than 20% or is determined to have weakened structural integrity of the pipe.	Pipe repaired or replaced.
Ditches	Trash and debris	Trash and debris exceeds 1 cubic foot per 1,000 square feet of ditch and slopes.	Trash and debris cleared from ditches.
	Sediment accumulation	Accumulated sediment that exceeds 20% of the design depth.	Ditch cleaned/flushed of all sediment and debris so that it matches design.
	Noxious weeds	Any noxious or nuisance vegetation which may constitute a hazard to County personnel or the public.	Noxious and nuisance vegetation removed according to applicable regulations. No danger of noxious vegetation where County personnel or the public might normally be.
	Contaminants and pollution	Any evidence of contaminants or pollution such as oil, gasoline, concrete slurries or paint.	Materials removed and disposed of according to applicable regulations. Source control BMPs implemented if appropriate. No contaminants present other than a surface oil film.
	Vegetation	Vegetation that reduces free movement of water through ditches.	Water flows freely through ditches.
	Erosion damage to slopes	Any erosion observed on a ditch slope.	Slopes are not eroding.
	Rock lining out of place or missing (If Applicable)	One layer or less of rock exists above native soil area 5 square feet or more, any exposed native soil.	Replace rocks to design standards.



<b>NO. 7 – DEBRIS BARRIERS (E.G., TRASH RACKS)</b>			
<b>Maintenance Component</b>	<b>Defect or Problem</b>	<b>Condition When Maintenance is Needed</b>	<b>Results Expected When Maintenance is Performed.</b>
Site	Trash and debris	Trash or debris plugging more than 20% of the area of the barrier.	Barrier clear to receive capacity flow.
	Sediment accumulation	Sediment accumulation of greater than 20% of the area of the barrier	Barrier clear to receive capacity flow.
Structure	Cracked broken or loose	Structure which bars attached to is damaged - pipe is loose or cracked or concrete structure is cracked, broken or loose.	Structure barrier attached to is sound.
Bars	Bar spacing	Bar spacing exceeds 6 inches.	Bars have at most 6 inch spacing.
	Damaged or missing bars	Bars are bent out of shape more than 3 inches.	Bars in place with no bends more than 3/4 inch.
		Bars are missing or entire barrier missing.	Bars in place according to design.
		Bars are loose and rust is causing 50% deterioration to any part of barrier.	Repair or replace barrier to design standards.



<b>NO. 8 – ENERGY DISSIPATERS</b>			
<b>Maintenance Component</b>	<b>Defect or Problem</b>	<b>Conditions When Maintenance is Needed</b>	<b>Results Expected When Maintenance is Performed.</b>
Site	Trash and debris	Trash and/or debris accumulation.	Dissipater clear of trash and/or debris.
	Contaminants and pollution	Any evidence of contaminants or pollution such as oil, gasoline, concrete slurries or paint.	Materials removed and disposed of according to applicable regulations. Source control BMPs implemented if appropriate. No contaminants present other than a surface oil film.
Rock Pad	Missing or moved Rock	Only one layer of rock exists above native soil in area five square feet or larger or any exposure of native soil.	Rock pad prevents erosion.
Dispersion Trench	Pipe plugged with sediment	Accumulated sediment that exceeds 20% of the design depth.	Pipe cleaned/flushed so that it matches design.
	Not discharging water properly	Visual evidence of water discharging at concentrated points along trench (normal condition is a "sheet flow" of water along trench).	Water discharges from feature by sheet flow.
	Perforations plugged.	Over 1/4 of perforations in pipe are plugged with debris or sediment.	Perforations freely discharge flow.
	Water flows out top of "distributor" catch basin.	Water flows out of distributor catch basin during any storm less than the design storm.	No flow discharges from distributor catch basin.
	Receiving area over-saturated	Water in receiving area is causing or has potential of causing landslide problems.	No danger of landslides.
Gabions	Damaged mesh	Mesh of gabion broken, twisted or deformed so structure is weakened or rock may fall out.	Mesh is intact, no rock missing.
	Corrosion	Gabion mesh shows corrosion through more than ¼ of its gage.	All gabion mesh capable of containing rock and retaining designed form.
	Collapsed or deformed baskets	Gabion basket shape deformed due to any cause.	All gabion baskets intact, structure stands as designed.
	Missing rock	Any rock missing that could cause gabion to loose structural integrity.	No rock missing.
Manhole/Chamber	Worn or damaged post, baffles or side of chamber	Structure dissipating flow deteriorates to ½ or original size or any concentrated worn spot exceeding one square foot which would make structure unsound.	Structure is in no danger of failing.
	Damage to wall, frame, bottom, and/or top slab	Cracks wider than ½-inch or any evidence of soil entering the structure through cracks, or maintenance inspection personnel determines that the structure is not structurally sound.	Manhole/chamber is sealed and structurally sound.
	Damaged pipe joints	Cracks wider than ½-inch at the joint of the inlet/outlet pipes or any evidence of soil entering the structure at the joint of the inlet/outlet pipes.	No soil or water enters and no water discharges at the joint of inlet/outlet pipes.



